

# Design LED Tri Brick

Elation Professional™  
6122 S. Eastern Ave.  
Los Angeles, Ca 90040  
[www.elationlighting.com](http://www.elationlighting.com)



# TABLE OF CONTENTS

## CONTENTS

1. General Information.....	3
a. Introduction.....	3
b. Unpacking.....	3
c. Customer Support.....	3
d. Warranty Registration.....	4
2. Safety Instructions.....	5
3. Features.....	7
4. General Guidelines.....	8
5. Fixture Overview.....	9
6. Mounting and Installation.....	12
a. Yoke Assembly.....	12
b. Mounting Positions.....	13
c. Mounting Points.....	13
d. Clamp Mounting.....	14
e. Securing.....	16
7. Understanding DMX.....	17
a. DMX Connections.....	18
b. DMX Terminator.....	19
c. 3-Pin to 5-Pin Conversion.....	19
d. Fixture DMX Addressing.....	19
8. Display LED Indicators.....	21
9. Display Menu.....	22
10. DMX Traits.....	24
a. 3-Channel Mode.....	24
b. 4-Channel Mode.....	25
c. 12-Channel Mode.....	26
d. 15-Channel Mode.....	28
11. Lens Replacement.....	31
12. Cleaning and Maintenance.....	32
13. Warranty.....	33
14. Photometric Data.....	35
15. Dimensional Drawings.....	36
16. Circuit Schematic.....	37
17. Technical Specifications.....	38

## 1. GENERAL INFORMATION

**INTRODUCTION:** Congratulations, you have just purchased one of the most innovative and reliable LED fixtures on the market today! The Design LED Tri Brick,™ has been designed to perform reliably for years when the guidelines in this booklet are followed. Please read and understand the instructions in this manual carefully and thoroughly before attempting to operate this unit. These instructions contain important information regarding safety during use and maintenance.

**UNPACKING:** Thank you for purchasing the Design LED Tri Brick™ by Elation Professional®. Every Design LED Tri Brick™ has been thoroughly tested and has been shipped in perfect operating condition. Carefully check the shipping carton for damage that may have occurred during shipping. If the carton appears to be damaged, carefully inspect your fixture for damage and be sure all accessories necessary to operate the fixture have arrived intact. In the event damage has been found or parts are missing, please contact our customer support team for further instructions. Inside the box you should find: the fixture, a DMX XLR cable, a safety cable, and this manual. Please do not return this unit to your dealer without first contacting customer support at the number listed below.

**CUSTOMER SUPPORT:** Elation Professional® provides a customer support line, to provide set up help and to answer any question should you encounter problems during your set up or initial operation. You may also visit us on the web at [www.elationlighting.com](http://www.elationlighting.com) for any comments or suggestions. For service related issue please contact Elation Professional®. Service Hours are Monday through Friday 9:00 a.m. to 5:00 p.m. Pacific Standard Time.

Voice: (323) 582-3322

Fax: (323) 832-9142

E-mail: [support@elationlighting.com](mailto:support@elationlighting.com)

Forum: [www.ElationLighting.com/forum](http://www.ElationLighting.com/forum)

**Warning!** To prevent or reduce the risk of electrical shock or fire, do not expose this unit to rain or moisture.

**Caution!** There are no user serviceable parts inside this unit. Do not attempt any repairs

yourself. Doing so will void your manufactures warranty.

*Please do not discard the shipping carton in the trash. Please recycle whenever possible.*

**WARRANTY REGISTRATION:** The Design LED Tri Brick™ carries a two year (730 days) limited warranty. Please fill out the enclosed warranty card to validate your purchase. All returned service items whether under warranty or not, must be freight pre-paid and accompany a return authorization (R.A.) number. The R.A. number must be clearly written on the outside of the return package. A brief description of the problem as well as the R.A. number must also be written down on a piece of paper and included in the shipping container. If the unit is under warranty, you must provide a copy of your proof of purchase invoice. Items returned without a R.A. number clearly marked on the outside of the package will be refused and returned at customer's expense. You may obtain a R.A. number by contacting customer support at (323) 582-3322.

## 2. SAFETY INSTRUCTIONS



To guarantee proper and consistent operation, it is important to follow the guidelines in this manual. Elation Professional will not accept responsibility for damages resulting from the misuse of this fixture due to the disregard of the information printed in this manual.

1. Always be sure that the fan and the air inlets remain clean and are never blocked. Allow about 6" (15cm) between this fixture and other devices or a wall to allow for proper cooling. See page 8.
2. Never touch the fixture during normal operation.
3. Never look directly into the light source. You risk injury to your retina, which may induce blindness.
4. For safe operation, follow the Installation guide described in chapter two of this manual. Operating the Design LED Tri Brick™ without suited safety aids such as safety cables or clamps can increase the risk of damage and/or personal injury.
5. Qualified and certified personnel should only perform installation.
6. When mounting this fixture, use only the original rigging points included with this fixture. Any structural modification will void the original manufacturer's warranty and may increase the risk of damage and/or personal injury.
7. To reduce the risk of fire or shock, do not expose this fixture to rain or moisture.
8. Do not attempt to operate this fixture if the power cord has become damaged or frayed.
9. **Never open this fixture while in use.**
10. This device falls under protection-class I. Therefore it is essential that the device be grounded properly.
11. All electrical connections should be performed by qualified personnel.
12. Be sure the available voltage matches the voltage requirements of the unit. Be

sure the power cord is never crimped or damaged. If the power cord is damaged, replace it immediately with a new one of similar power rating.

13. Always disconnect from main power before performing any type of service or any cleaning procedure.

14. Only handle the power cord by the plug. Never pull out the plug by tugging the wire portion of the cord.

15. ***Please be aware that damages caused by modifications to the device are not subject to warranty.***

***Important Notice: Damages resulting from the disregard of safety and general user instructions found in this user manual are not subject to any warranty claims.***

### 3. FEATURES

- Low power consumption
- Minimal heat emission
- Maintenance free operation
- Equipped with 12 1-Watt Tri-Color LEDs (36 LEDs Total)
- No Tri-Color Shadows
- High power LEDs manufactured by Lumileds, USA
- 100,000 hours ***rated*** LED life
- Step-less RGB color changing
- USITT DMX-512 Complaint
- Preprogrammed colored macros
- Strobe-effect with a maximum flash rate of 18fps
- DMX-controlled operation or stand-alone operation with Master/Slave-function
- 8 built-in programs can be called up via DMX-controller
  - ~ 48 preprogrammed scenes per a program
- Sound-controlled via built-in microphone
- Four DMX Modes:
  - 15 DMX channels
  - 12 DMX channels
  - 4 DMX channels
  - 3 DMX channels
- DMX-control via standard DMX-controller
- 3-pin and 5-pin DMX connectors
- Flicker-free operation for television and film
- Compact design: fits in 12" box truss
- Brilliant light output



## 4. GENERAL GUIDELINES

This fixture is a professional lighting effect designed for use on stage, in nightclubs, in theatres, and other types of architectural installations. Do not attempt operation or installation without a proper knowledge on how to do so.

This fixture was designed for indoor use only; use of this fixture outside will void the manufacture's warranty.

Consistent operational breaks will ensure that the fixture will function properly for many years to come.

Do not shake the fixture around. Avoid brute force when installing or operating the fixture.

While choosing an installation location, please be sure that the fixture will not be exposed to extreme heat, moisture, or dust. The minimum distance between the fixture and a wall or flat surface should be at least 0.5 meter (about 1.5ft). See page 5.

Always install the fixture with an appropriately rated safety cable. When installing the fixture in a suspended environment always be sure to use mounting hardware no less than M10 x 25 mm, also be sure the hardware is only inserted in the yoke's mounting holes.

Do not attempt to operate this fixture until you have familiarized yourself with all of its functions.

Do not permit operation by persons not qualified for operating this type of theatrical fixture. Most damages are the result of improper operation.

Please use the original packaging to transport the fixture in for service.

For your own safety, please read this user manual carefully before installing the device.

## 5. FIXTURE OVERVIEW

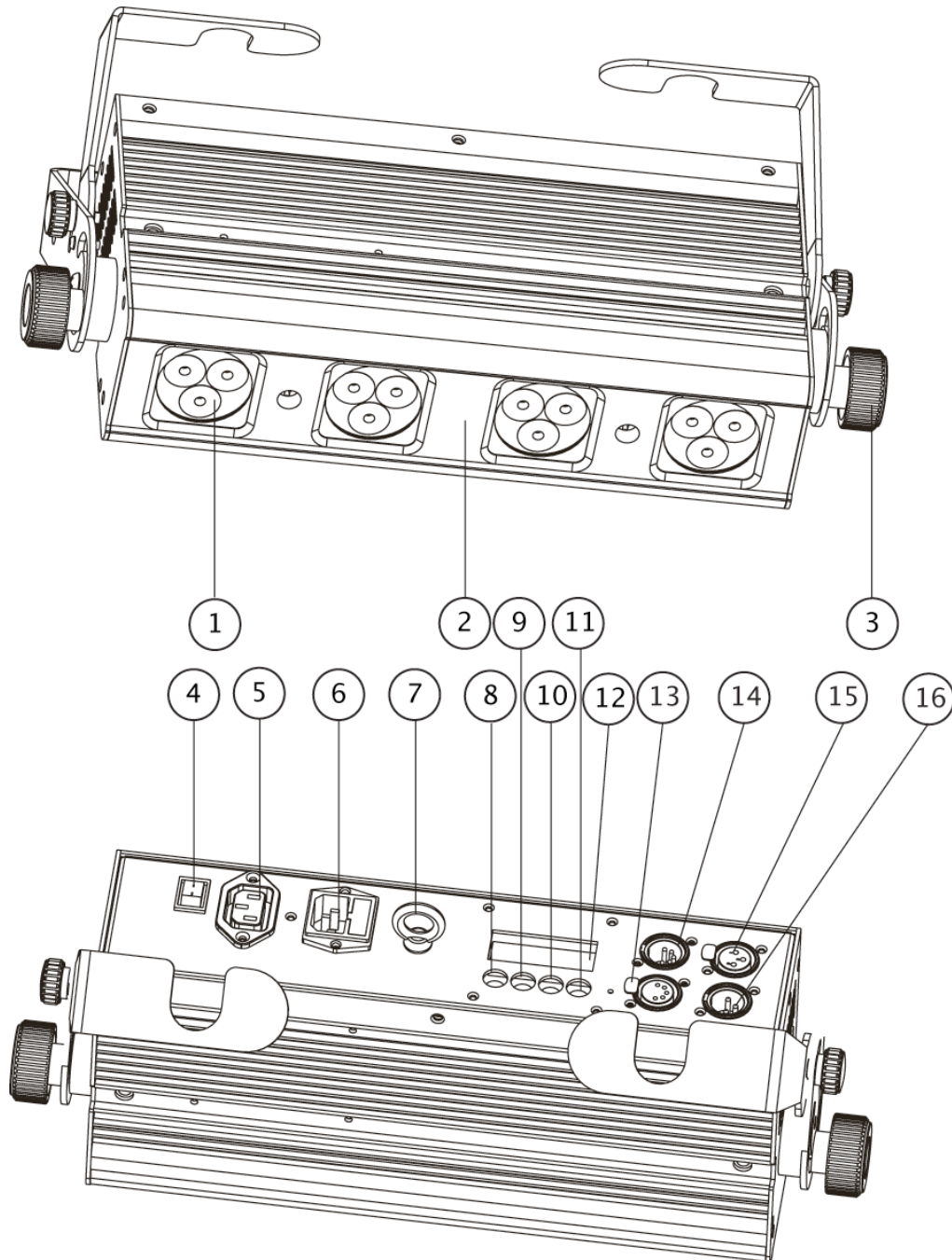

1. **LED Lens Assembly** – The lens assembly may be user replaced in the event repair is needed or a different beam angle is required.
2. **Lens Cover** – This cover holds the lens assemblies in place and is easily removed.

3. **Hanging Bracket Locking Knob** – This knob is used to secure the hanging bracket in to place.
4. **On/Off Power Switch** – Controls main power to the unit.
5. **Power Output Jack** – Use this jack to jump power to another Design LED Tri Brick™ in an array system.
6. **Power Input/Fuse Holder Assembly** – This assembly holds the safety fuse as well as provides a female IEC connector for a power cord. Always replace the fuse with an exact match unless otherwise specified by an authorized Elation Service Technician. Using a fuse other than that specified could seriously damage the unit and will void your manufactures warranty.
7. **Eye-Bolt** – Use this bold as a safety-cable rigging point. Always secure any installation with a properly rated safety-cable.
8. **Menu Button** – This button is used to access the fixtures menu functions.
9. **Up Button** – The up button is used to toggle forward through the menu functions and settings.
10. **Down Button** – The down button is used to toggle backwards through the menu functions and settings.
11. **Enter Button** – The enter button is used to enter in to a certain menu function or to lock a menu setting in to memory.
12. **LED Display** – 4-segment menu display. Used to display the DMX address as well as all other menu functions.

- 13. 5-pin DMX In Jack** – This jack accepts an incoming DMX signal via a male, 5-pin XLR jack.
  
- 14. 5-pin DMX Out Jack** – This jack is used to send an incoming DMX signal to the next fixture in the DMX chain via a female, 5-pin XLR jack.
  
- 15. 3-pin DMX Out Jack** – This jack is used to send an incoming DMX signal to the next fixture in the DMX chain via a female, 3-pin XLR jack.
  
- 16. DMX In Jack** – This jack accepts an incoming DMX signal via a male, 3-pin XLR jack.

## 6. MOUNTING AND INSTALLATION

### Yoke Assembly – Single Unit Operation

The device can be placed directly on the stage floor or rigged in any orientation on a truss without altering its operation characteristics. When connecting the hanging yoke to the fixture, refer to the illustration below.

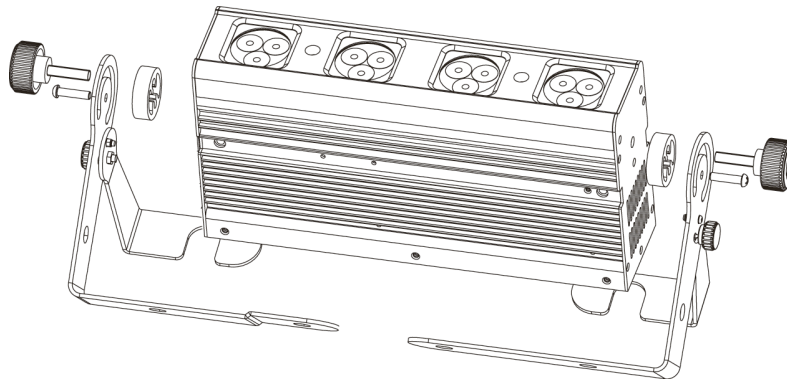

### Yoke Assembly – Multiple Unit Operation

You can connect up to four Design LED Tri Bricks together in a bar assembly. To connect multiple units together use the included mounting hardware and refer to the diagram below.

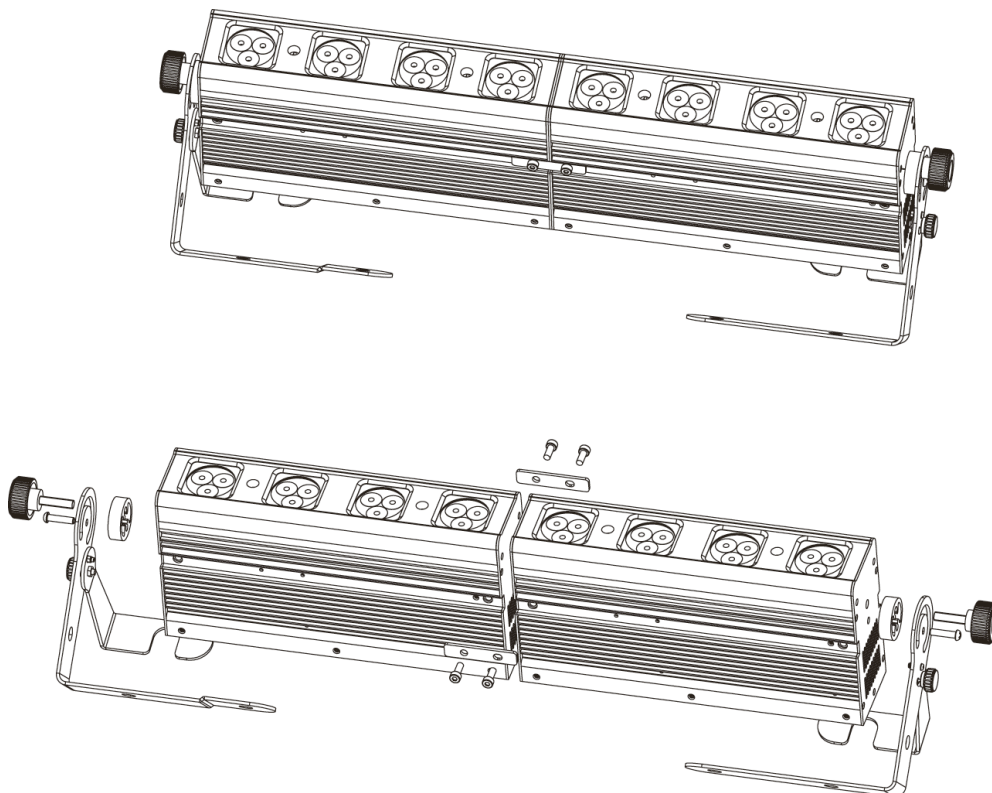

***Please note:*** To ensure maximum stability, no more than four units should be mounted together in this fashion. Connecting more than four units will result in an unstable assembly, which could collapse and damage the units.

### **Cautions:**

For added protection mount the fixtures in areas outside walking paths, seating areas, and away from areas where the fixture might be reached by unauthorized personnel.

Before mounting the fixture to any surface, make sure that the installation area can hold a minimum point load of 10 times the device's weight.

Fixture installation must always be secured with a secondary safety attachment, such as an appropriate safety cable.

To avoid injury, never stand directly below the device when mounting, removing, or servicing the fixture.

	<p><b>Refer to regulations BGV C1 (formerly VBG 70) and DIN VDE0711-217 for proper installation in Europe To ensure proper installation, only qualified staff should attempt installation.</b></p>
-------------------------------------------------------------------------------------	----------------------------------------------------------------------------------------------------------------------------------------------------------------------------------------------------

### ***Mounting points***

Overhead mounting requires extensive experience, including amongst others calculating working load limits, a fine knowledge of the installation material being used, and periodic safety inspection of all installation material and the fixture. If you lack these qualifications, do not attempt the installation yourself. Improper installation can result in bodily injury.

	<p><b>CAUTION!</b> <b>Be sure a qualified electrician performs all electrical connections.</b></p>
-------------------------------------------------------------------------------------	--------------------------------------------------------------------------------------------------------

*Be sure to complete all rigging and installation procedures before connecting the main*

power cord to the appropriate wall outlet.

### **Mounting**

The Design LED Tri Brick™ is fully operational in any mounting position, hanging upside-down from a ceiling, side mounted, or set on a flat level surface, etc. Be sure this fixture is kept at least 0.5m away from any flammable materials (decoration etc.). When clamp mounting; always use and install the supplied safety cable as an added safety measure to prevent accidental damage in the event of a clamp failure. **See the image below.**

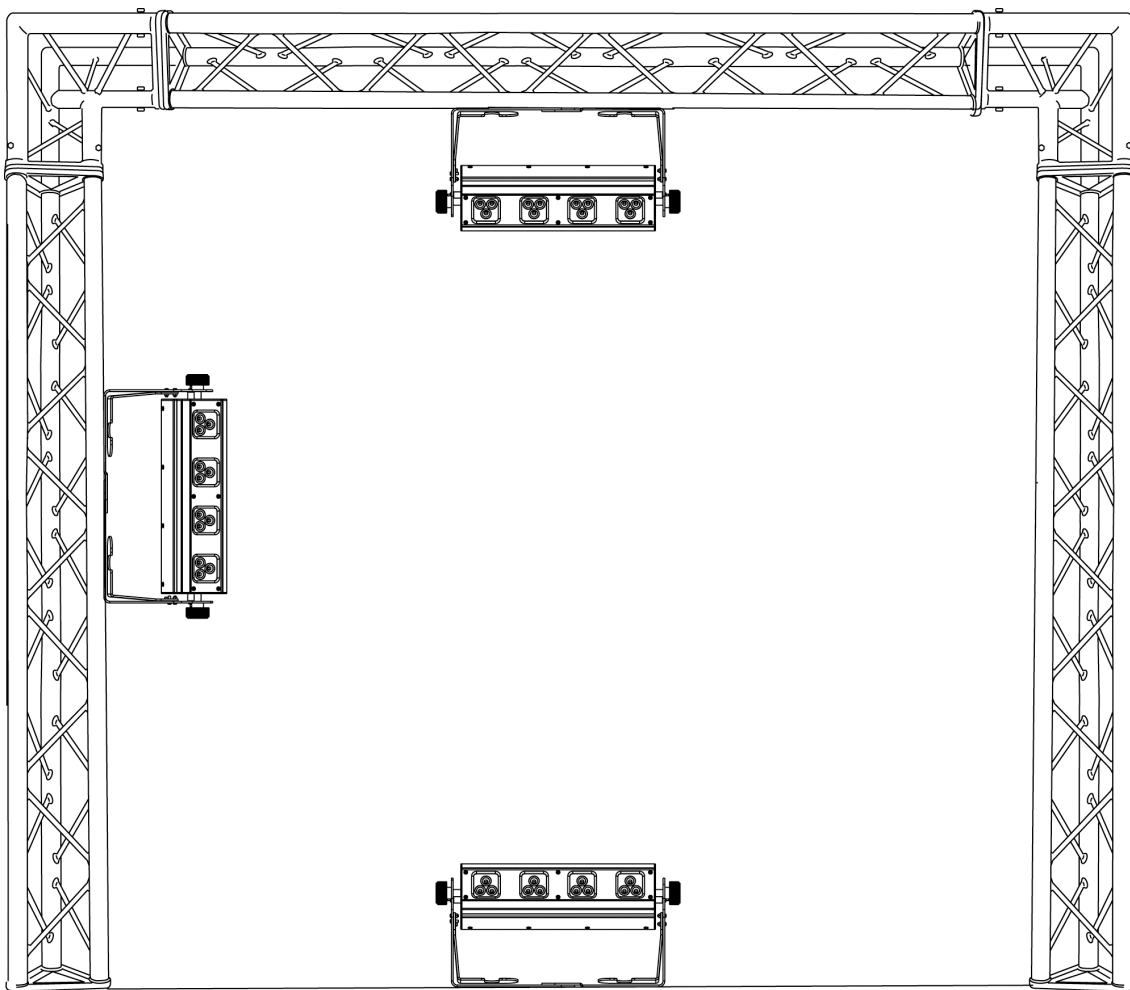

### **Clamp Mounting**

The Design LED Tri Brick™ provides a unique mounting bracket assembly that allows the unit to stand on flat surface, hang on truss via a clamp, or be used in cluster allow multiple

units to rigged together (see the illustration below). Regardless of the mounting option you choose please refer to the safety guidelines in this manual to avoid damage to the unit and/or injury to persons.

When mounting this fixture to truss be sure to secure an appropriately rated clamp to the hanging yoke using a M10 screw fitted through the center hole of the hanging yoke. As an added safety measure be sure to attach at least one properly rated safety cable to the fixture. See illustrations below.

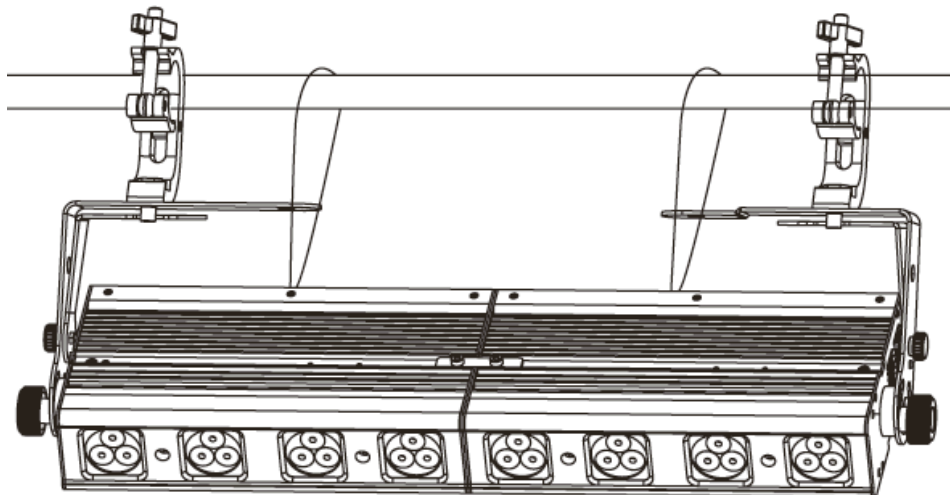
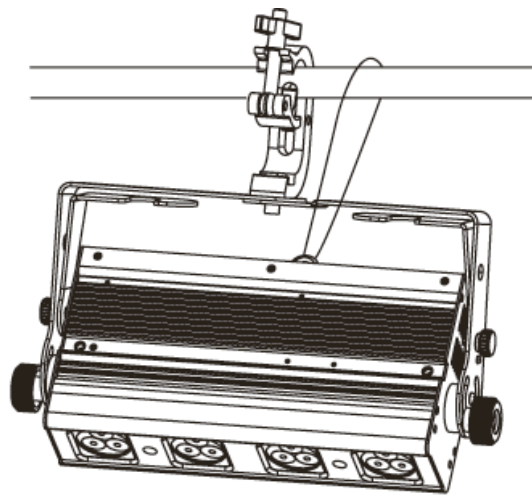



## Securing the Design LED Tri Brick™



***Always be sure to secure your fixture with a safety cable when suspending the unit from truss or other means. The fixture provides a built-in rigging point for a safety cable as illustrated above. Be sure to only use the designated rigging point for the safety cable and never secure a safety cable to the hanging bracket.***

## 7. UNDERSTANDING DMX

**DMX-512:** DMX is short for Digital Multiplex. This is a universal protocol used by most lighting and controller manufactures as a form of communication between intelligent fixtures and controllers. DMX allows all makes and models of different manufactures to be linked together and operate from a single controller. This is possible as long as all the fixtures and the controller are DMX compliant. A DMX controller sends the DMX data instructions to a fixture allowing the user to control the different aspects of an intelligent light. DMX data is sent out as serial data that travels from fixture to fixture via data “IN” and “OUT” XLR terminals located on the fixtures (most controllers will only have output jacks).

**DMX Linking:** To ensure proper DMX data transmission, always use proper DMX cables and a terminator. When using several DMX fixtures try to use the shortest cable path possible. Never split a DMX line with a “Y” style connector. The order in which the fixtures are connected in a DMX line does not influence the DMX addressing. For example; a fixture assigned a DMX address of 1 may be placed anywhere in the DMX chain, at the beginning, at the end, or anywhere in the middle. The DMX controller knows to send data assigned to address 1 to that fixture no matter where it is located in the DMX chain. The Design LED Tri-Brick™ can be controlled via DMX-512 protocol. The Design LED Tri-Brick™ is a fixture that can operate in 3, 5, 12, or 15 DMX channels (see page 24 for the different DMX operations). The DMX address is set electronically using the controls on the LED menu.

**Data Cable (DMX Cable) Requirements (For DMX and Master/Slave Operation):** Your fixture and your DMX controller require a standard 3-pin or 5-pin XLR connector for data input and data output (the illustration on the next page is of a 3-Pin XLR connector). If you are making your own cables, be sure to use two conductor shielded digital DMX cable rated at 120 ohms, this cable is designed for DMX transmission and may be purchased from your Elation dealer or at most professional lighting retailers. Your cables should be made with a male and female XLR connector on either end of the cable. Also, remember that a DMX line must be daisy chained and cannot be split, unless using an approved DMX splitter such as the Elation Opto Branch 4™ or DMX Branch/4™.

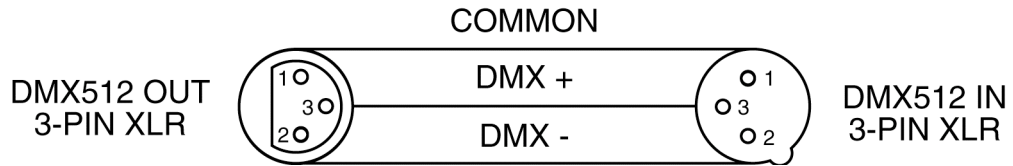

Be sure to follow the above figure when making your own cables. Do not use the ground lug on the XLR connector. Do not connect the cable's shield conductor to the ground lug or allow the shield conductor to come in contact with the XLR's outer casing. Grounding the shield could cause a short circuit and erratic behavior.

DMX Output  
3-Pin XLR Socket



DMX Input  
3-Pin XLR Socket

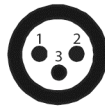

- 1: Ground
- 2: Data (-)
- 3: Data (+)

DMX Output  
5-Pin XLR Socket

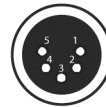

DMX Input  
5-Pin XLR Socket

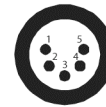

- 1: Ground
- 2: Data (-)
- 3: Data (+)
- 4: Open
- 5: Open

**DMX-512 control connection**

Connect the provided XLR cable to the female 3-pin XLR output of your controller and the other side to the male 3-pin XLR input of the fixture (Please refer to the diagram below.). You can chain multiple fixtures together through serial linking. The cable needed should be two conductor, shielded cable with XLR input and output connectors. Always be sure daisy chain your in and out data connections, never split or “Y” your DMX connections unless you are using an approved DMX splitter such as the Elation Opto Branch 4™ or DMX Branch/4™.

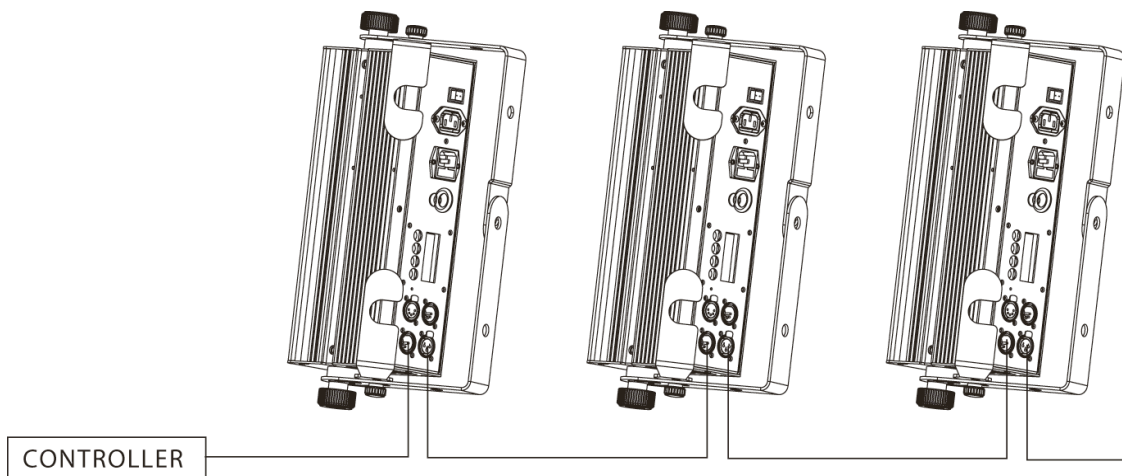

**DMX-512 connection with DMX terminator**

A DMX terminator should be used in all DMX lines especially in longer runs. The use of a terminator may avoid erratic behavior in your DMX line. A terminator is a 120 ohm 1/4 watt resistor that is connected between pins 2 and 3 of a male XLR connector (DATA + and DATA -). This fixture is inserted in the female XLR connector of the last fixture in your daisy chain to terminate the line. Using a *line terminator (Elation part: DMX T PACK)* will decrease the possibilities of erratic behavior.

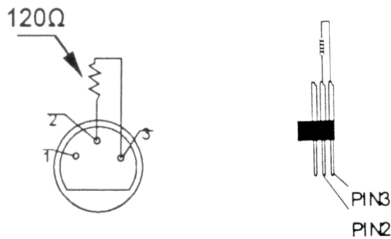

Termination reduces signal errors and avoids signal transmission problems and interference. It is always advisable to connect a DMX terminal, (Resistance 120 Ohm 1/4 W) between PIN 2 (DMX-) and PIN 3 (DMX +) of the last fixture.

**5-Pin XLR DMX Connectors.** Some manufactures use 5-pin XLR connectors for DATA transmission in place of 3-pin. 5-pin XLR fixtures may be implemented in a 3-pin XLR DMX line. When inserting standard 5-pin XLR connectors in to a 3-pin line a cable adaptor must be used, these adaptors are readily available at most electric stores. The following chart details a proper cable conversion.

3-Pin XLR to 5-Pin XLR Conversion		
Conductor	3-Pin XLR Female (Out)	5-Pin XLR Male (In)
Ground/Shield	Pin 1	Pin 1
Data Compliment (- signal)	Pin 2	Pin 2
Data True (+ signal)	Pin 3	Pin 3
Not Used		Pin 4 - Do Not Use
Not Used		Pin 5 - Do Not Use

**Fixture DMX addressing;**

All fixtures should be given a DMX starting address when using a DMX controller, so the correct fixture responds to the correct control signal. This digital starting address is the

channel number from which the fixture starts to “listen” to the digital control information sent out from the DMX controller. The allocation of this starting DMX address is achieved by setting the correct DMX address on the digital display located on the back of the fixture.

You can set the same starting address for all fixtures or a group of fixtures, or set different address for each individual fixture. Be advised that setting all your fixtures to the same DMX address will subsequently control all fixtures in the same fashion, in other words, changing the settings of one channel will affect all the fixtures simultaneously.

If you set each fixture to a different DMX address, each unit will start to “listen” to the channel number you have set, based on the quantity of control channels (DMX channels) of each fixture. That means changing the settings of one channel will only affect the selected fixture.

In the case of the Design LED TRI Brick™, which is up to a 15 channel fixture, you should set the starting DMX address of the first unit to 1, the second unit to 16 (15 + 1), the third unit to 31 (15 + 16), and so on.

**Note:** During start-up the Design LED TRI Brick™ will automatically detect whether a DMX data signal is being received or not. If a DMX data signal is being received, the display will show "**A.XXX**" (**XXX** representing the actual DMX address). If the fixture is not receiving a DMX signal the display will flash "**A.XXX**" (**XXX** representing the actual DMX address).

If your fixture is connected to a DMX controller and the display is flashing (not receiving a DMX signal), please check the following:

- The 3-pin or 5-pin XLR plug (cable with DMX signal from controller) may not be connected or is not inserted completely into the DMX input jack.
- The DMX controller is switched off or defective.
- The DMX cable or connector is defective.
- A DMX terminator has been inserted into the last fixture in your DMX chain.

## 8. DISPLAY LED INDICATORS.

The Design LED TRI Brick™ has two LED indicators on the display. These indicators are designed to give a quick visual indication of the fixtures' status. The illustration below details the functionality of the LED indicators.

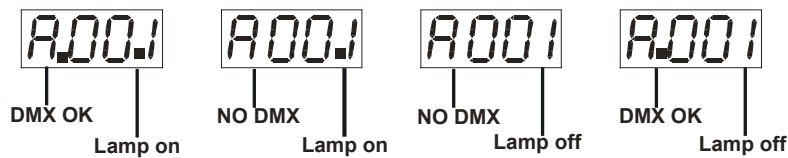

The first LED indicators represents DMX signal:

- If the indicators is on a clean DMX signal is present
- If the indicator is off there is no DMX signal present

The second LED indicator represents lamp condition; this is only applicable to fixtures with traditional lamp sources.

## 9. DISPLAY MENU

Default settings shaded.

<b>MODE</b>	<b>ADDR</b>		<i>AXXX (1-512)</i>		Set the starting DMX address	
	<b>CHAL</b>	<b>C03</b>		Set to 3 channel mode - Default		
		C04		Set to 4 channel mode		
		C012		Set to 12channel mode		
		C015		Set to 15channel mode		
<b>SLAV</b>		<b>ON/OFF</b>	Run as slave.			
<b>MANU - Manual Control</b>	CNTL	MAST		Fixture will function as a master unit in Master/Slave mode		
		<b>ALON</b>		Fixture will function "Stand Alone" mode		
	BLAC	BLACKOUT - LED OUTPUT OFF				
	COLR	RED	RXXX	Manual Mode - Manual setting of RED levels		
		<i>GRN</i>	GXXX	Manual Mode - Manual setting of GREEN levels		
		<i>BLU</i>	BXXX	Manual Mode - Manual setting of BLUE levels		
		<i>STRB</i>	SXXX	Manual Mode - Manual setting of STROBE rate		
<b>CHAS - Built-In Program Selection</b>	CHS1	<i>SPED</i>		SXXX	Adjust program 1 speed	
		<i>FADE</i>		FXXX	Adjust program 1 fade time	
		<i>STRB</i>		SXXX	Adjust strobe of program 01	
	CHS2	<i>SPED</i>		SXXX	Adjust program 2 speed	
		<i>FADE</i>		FXXX	Adjust program 2 fade time	
		<i>STRB</i>		SXXX	Adjust strobe of program 01	
	CHS3	<i>SPED</i>		SXXX	Adjust program 3 speed	
		<i>FADE</i>		FXXX	Adjust program 3 fade time	
		<i>STRB</i>		SXXX	Adjust strobe of program 01	
	CHS4	<i>SPED</i>		SXXX	Adjust program 4 speed	
		<i>FADE</i>		FXXX	Adjust program 4 fade time	
		<i>STRB</i>		SXXX	Adjust strobe of program 01	
	CHS5	<i>SPED</i>		SXXX	Adjust program 5 speed	
		<i>FADE</i>		FXXX	Adjust program 5 fade time	
		<i>STRB</i>		SXXX	Adjust strobe of program 01	
	CHS6	<i>SPED</i>		SXXX	Adjust program 6 speed	
		<i>FADE</i>		FXXX	Adjust program 6 fade time	
		<i>STRB</i>		SXXX	Adjust strobe of program 01	
	CHS7	<i>SPED</i>		SXXX	Adjust program 7 speed	
		<i>FADE</i>		FXXX	Adjust program 7 fade time	
		<i>STRB</i>		SXXX	Adjust strobe of program 01	
	CHS8	<i>SPED</i>		SXXX	Adjust program 8 speed	
		<i>FADE</i>		FXXX	Adjust program 8 fade time	

		<i>STRB</i>	SXXX	Adjust strobe of program 01
<b>OTHE</b>	<i>DIMR</i>	<b><u>MOD1</u></b>		Fixture will function with a stepping dimmer rate
		MOD2		Fixture will function with a dimming rate of 0~100%
	REST	YES		Reloads the built-in preset
	VER	VX.X		"X.X" will represent the fixture's current firmware version

**Remarks:**

- 1) **If the fixture does not receive a DMX signal the menu display will flash repeatedly.**
- 2) **SPED: Adjust the hold time for each scene in built-in chase programs.**
- 3) **FADE: Adjust the fade time between each scene in the built-in programs.**



## 10. DMX TRAITS

### DMX Operation Notes:

*The fixture will function in DMX mode whenever the unit is receiving a DMX signal. Please note that this will override all manual settings.*

*This unit will keep and retain the last DMX command in the event of DMX signal failure. To reset the fixture you must turn the power off.*

### DMX CHANNEL TRAITS

*The charts below outline the different DMX traits for the 4 different DMX modes.*

**3-Channel mode:** In this mode channel 1 controls all the red LEDs, channel 2 controls all the green LEDs, and channels 3 controls all the blue LEDs.

CHANNEL 1:Red

CHANNEL 2:Green

CHANNEL 3:Blue

*3 Channel Mode:* The chart below details the DMX channel layout for 3-channel assignment.

#### DMX channel's functions and their values (3 Channel Mode):

<b><u>Channel 1 - Red:</u></b>	
0-255	Red (0-Black, 255 - 100% Red)
<b><u>Channel 2 - Green:</u></b>	
0-255	Green (0-Black, 255 - 100% Green)
<b><u>Channel 3 - Blue:</u></b>	
0-255	Blue (0-Black, 255 - 100% Blue)

**4-Channel mode:** In this mode channel 1 controls all the red LEDs, channel 2 controls all the green LEDs, channels 3 controls all the blue LEDs, and channel 4 will control the master dimming level.

CHANNEL 1:Red

CHANNEL 2:Green

CHANNEL 3:Blue

CHANNEL 4:Dimmer/Speed

*4 Channel Mode:* The chart below details the DMX channel layout for 4-channel assignment.

**DMX channel's functions and their values (4 Channel Mode):**

<b><u>Channel 1 - Red:</u></b>	
0-255	Red (0-Black, 255 - 100% Red)
<b><u>Channel 2 - Green:</u></b>	
0-255	Green (0-Black, 255 - 100% Green)
<b><u>Channel 3 - Blue:</u></b>	
0-255	Blue (0-Black, 255 - 100% Blue)
<b><u>Channel 4 - Dimming / Program Speed Control</u></b>	
<i>This channel has two functions depending on the operating mode. When running the built-in programs this channel will control the program speed.</i>	
0-255	Dimming (0%-100%) ~ Normal Operation
0-255	Speed (min to max) ~ When running built-in programs on channel 4

**12-Channel mode:** In this mode all channels are used to control the various RGB LEDs.

CHANNEL 1:Red

CHANNEL 2:Green

CHANNEL 3:Blue

CHANNEL 4:Red

CHANNEL 5:Green

CHANNEL 6:Blue

CHANNEL 7:Red

CHANNEL 8:Green

CHANNEL 9:Blue

CHANNEL 10:Red

CHANNEL 11:Green

CHANNEL 12:Blue

*12 Channel Mode:* The chart below details the DMX channel layout for 12-channel assignment.

**DMX channel's functions and their values (12 Channel Mode):**

<b><u>Channel 1 - Red:</u></b>	
0-255	Red (0-Black, 255-100% Red)
<b><u>Channel 2 - Green:</u></b>	
0-255	Green (0-Black, 255- 100% Green)
<b><u>Channel 3 - Blue:</u></b>	
0-255	Blue (0-Black, 255- 100% Blue)
<b><u>Channel 4 - Red:</u></b>	
0-255	Red (0-Black, 255-100% Red)

**Channel 5 - Green:**

0-255	Green (0-Black, 255- 100% Green)

**Channel 6 - Blue:**

0-255	Blue (0-Black, 255- 100% Blue)

**Channel 7 - Red:**

0-255	Red (0-Black, 255-100% Red)

**Channel 8 - Green:**

0-255	Green (0-Black, 255- 100% Green)

**Channel 9 - Blue:**

0-255	Blue (0-Black, 255- 100% Blue)

**Channel 10 - Red:**

0-255	Red (0-Black, 255-100% Red)

**Channel 11 - Green:**

0-255	Green (0-Black, 255- 100% Green)

**Channel 12 - Blue:**

0-255	Blue (0-Black, 255- 100% Blue)

**15-Channel mode:** In this mode channels 1~12 are used to control the various RGB LEDs and channels 13~15 will control special features.

- CHANNEL 1:Red
- CHANNEL 2:Green
- CHANNEL 3:Blue
- CHANNEL 4:Red
- CHANNEL 5:Green
- CHANNEL 6:Blue
- CHANNEL 7:Red
- CHANNEL 8:Green
- CHANNEL 9:Blue
- CHANNEL 10:Red
- CHANNEL 11:Green
- CHANNEL 12:Blue
- CHANNEL 13:Auto Programs (Built-in Programs)
- CHANNEL 14:Strobe
- CHANNEL 15:Dimmer/Speed

**15 Channel Mode:** The charts below and on the next page detail the DMX channel layout for 15-channel assignment.

Channel mode15:

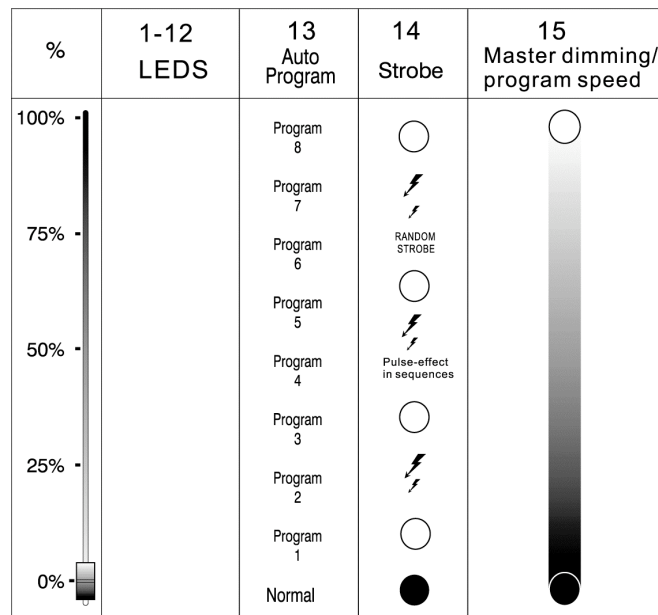

**DMX channel's functions and their values (15 Channel Mode):**

<b><u>Channel 1 - Red:</u></b>	
0-255	Red (0-Black, 255-100% Red)
<b><u>Channel 2 - Green:</u></b>	
0-255	Green (0-Black, 255- 100% Green)
<b><u>Channel 3 - Blue:</u></b>	
0-255	Blue (0-Black, 255- 100% Blue)
<b><u>Channel 4 - Red:</u></b>	
0-255	Red (0-Black, 255-100% Red)
<b><u>Channel 5 - Green:</u></b>	
0-255	Green (0-Black, 255- 100% Green)
<b><u>Channel 6 - Blue:</u></b>	
0-255	Blue (0-Black, 255- 100% Blue)
<b><u>Channel 7 - Red:</u></b>	
0-255	Red (0-Black, 255-100% Red)
<b><u>Channel 8 - Green:</u></b>	
0-255	Green (0-Black, 255- 100% Green)
<b><u>Channel 9 - Blue:</u></b>	
0-255	Blue (0-Black, 255- 100% Blue)
<b><u>Channel 10 - Red:</u></b>	
0-255	Red (0-Black, 255-100% Red)

**Channel 11 - Green:**

0-255	Green (0-Black, 255- 100% Green)

**Channel 12 - Blue:**

0-255	Blue (0-Black, 255- 100% Blue)

**Channel 13 - Internal programs:**

0-10	No function
------	-------------

11-40	Internal program 1
-------	--------------------

41-70	Internal program 2
-------	--------------------

71-100	Internal program 3
--------	--------------------

101-130	Internal program 4
---------	--------------------

131-160	Internal program 5
---------	--------------------

161-190	Internal program 6
---------	--------------------

191-220	Internal program 7
---------	--------------------

221-255	Internal program 8

**Channel 14 - Strobe:**

0	No function
---	-------------

1~95	Strobe effect slow to fast
------	----------------------------

96-127	No function
--------	-------------

128-159	Pulse effect in sequences
---------	---------------------------

160-191	No function
---------	-------------

192-223	Random strobe effect slow to fast
---------	-----------------------------------

224-255	No function

**Channel 15 - General dimming / Program Speed Control**

*This channel has two functions depending on the operating mode. When running the built-in programs this channel will control the program speed, when not running the built-in programs this channel will control master dimming.*

0-255	Dimming (0%-100%) ~ Normal Operation
-------	--------------------------------------

0-255	Speed (min to max) ~ When running built-in programs on channel 4
-------	------------------------------------------------------------------

## 11. LENS REPLACEMENT

The Design LED Tri Brick comes with a removable front cover that allows lens assembly to be changed out to achieve different beam angles.

Lens cover is held in place by two ¼ turn locking fasteners. To remove the cover; 1) Turn the locking fasteners in a counter-clockwise direction. 2) Once the fasteners are loose lift the cover the outer protective cable (see first illustration below). 3) Locate the 8 securing screws on the inner cover and remove them. 4) Remove the inner cover to access the lenses (see second illustration below). Once the lenses are changed reassemble in reverse order.

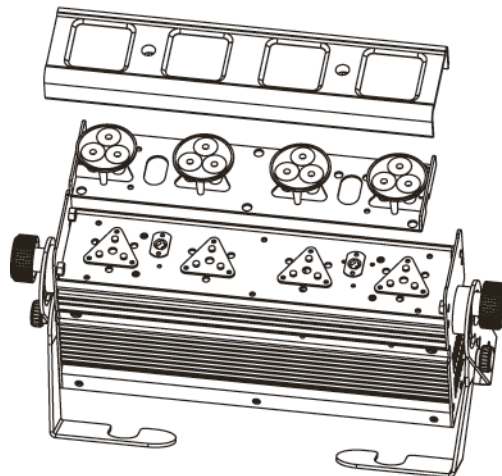
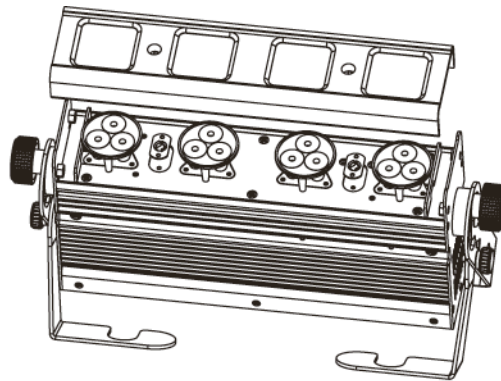



## 12. CLEANING AND MAINTENANCE

Consider the following points during normal service and inspection:

1. Be sure all screws and fasteners are securely tightened at all times. Loose screws may fall out during normal operation resulting in damage or injury as larger parts could fall.
2. Electric power supply cables must not show any damage, material fatigue or sediments. Never remove the ground prong from the power cable.

*Further instructions depending on the installation spot and usage have to be adhered by a skilled installer and any safety problems have to be removed.*



### CAUTION!

Disconnect from mains before starting maintenance operation.

We recommend a frequent cleaning of the device. Please use a moist, lint-free cloth. Never use alcohol or solvents.

There are no user serviceable parts inside this fixture, please refer all other service issues to an authorized Elation service technician.

Should you need any spare parts, please order genuine parts from your local dealer.

### 13. 2-YEAR LIMITED WARRANTY

A. Elation Professional® hereby warrants, to the original purchaser, Elation Professional® products to be free of manufacturing defects in material and workmanship for a period of two years, (730 days) from the date of purchase. This warranty shall be valid only if the product is purchased within the United States of America, including possessions and territories. It is the owner's responsibility to establish the date and place of purchase by acceptable evidence, at the time service is sought.

B. For warranty service, send the product only to the Elation Professional® factory. All shipping charges must be pre-paid. If the requested repairs or service (including parts replacement) are within the terms of this warranty, Elation Professional® will pay return shipping charges only to a designated point within the United States. If the entire instrument is sent, it must be shipped in its original package. No accessories should be shipped with the product. If any accessories are shipped with the product, Elation Professional® shall have no liability what so ever for loss of or damage to any such accessories, nor for the safe return thereof.

C. This warranty is void if the serial number has been altered or removed; if the product is modified in any manner which Elation Professional® concludes, after inspection, affects the reliability of the product; if the product has been repaired or serviced by anyone other than the Elation Professional® factory unless prior written authorization was issued to purchaser by Elation Professional®; if the product is damaged because not properly maintained as set forth in the instruction manual.

D. This is not a service contract, and this warranty does not include maintenance, cleaning or periodic check-up. During the period specified above, Elation Professional® will replace defective parts at its expense, and will absorb all expenses for warranty service and repair labor by reason of defects in material or workmanship. The sole responsibility of Elation Professional® under this warranty shall be limited to the repair of the product, or replacement thereof, including parts, at the sole discretion of Elation Professional®. All products covered by this warranty were manufactured after January 1, 1990, and bare identifying marks to that

effect.

E. Elation Professional® reserves the right to make changes in design and/or improvements upon its products without any obligation to include these changes in any products theretofore manufactured.

F. No warranty, whether expressed or implied, is given or made with respect to any accessory supplied with products described above. Except to the extent prohibited by applicable law, all implied warranties made by Elation Professional® in connection with this product, including warranties of merchantability or fitness, are limited in duration to the warranty period set forth above. And no warranties, whether expressed or implied, including warranties of merchantability or fitness, shall apply to this product after said period has expired. The consumer's and or Dealer's sole remedy shall be such repair or replacement as is expressly provided above; and under no circumstances shall Elation Professional® be liable for any loss or damage, direct or consequential, arising out of the use of, or inability to use, this product.

G. This warranty is the only written warranty applicable to Elation Professional® Products and supersedes all prior warranties and written descriptions of warranty terms and conditions heretofore published.

## 14. PHOTOMETRIC DATA

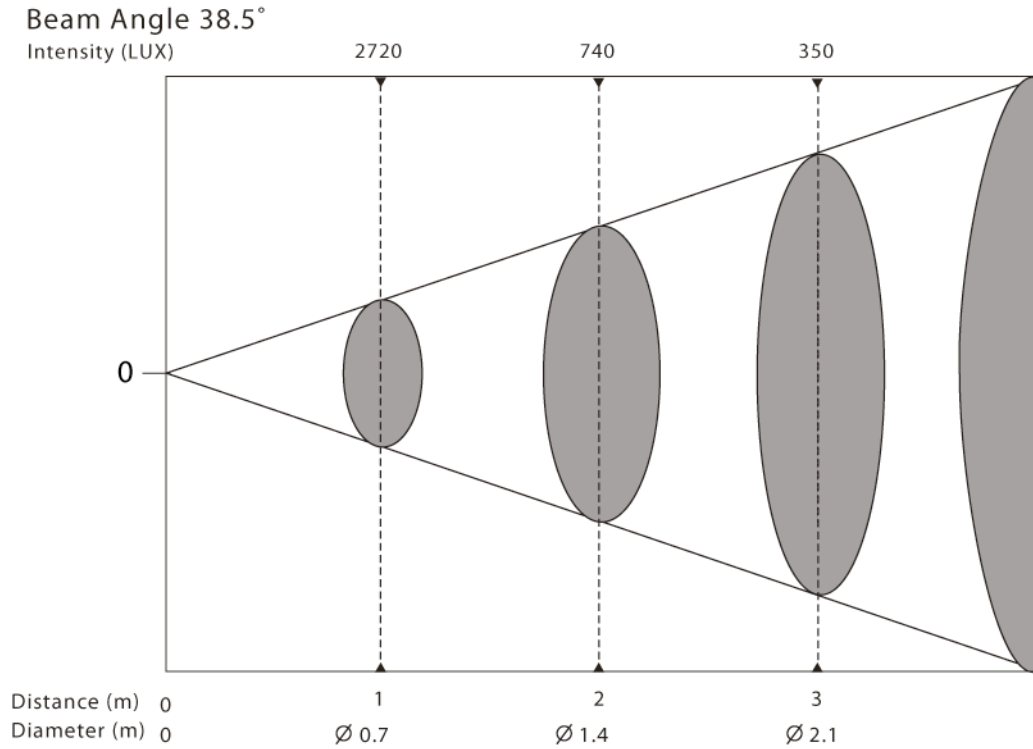

Distance	Diameter	A1	B1	B2	B3	B4	Average	Angle
1m	0.7m	1750	1610	1640	1420	540	1227	38.5°
2m	1.4m	650	600	640	680	440	561	38.5°
3m	2.1m	321	312	328	325	267	301	38.5°

Note: A1, B1, B2, B3, and B4 represent different measuring point in the beam field

## 15. DIMENSIONAL DRAWINGS

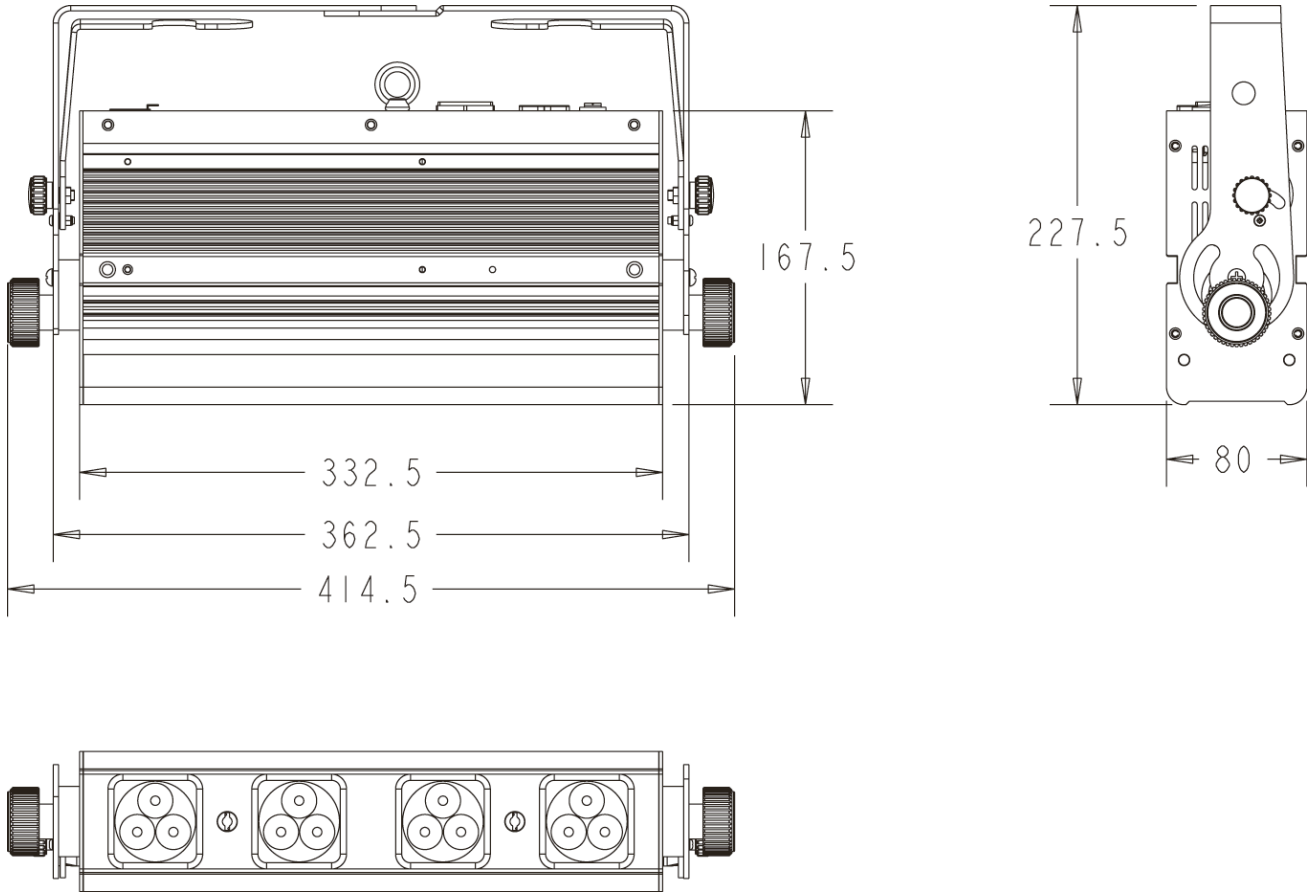

## 16. CIRCUIT SCHEMATIC

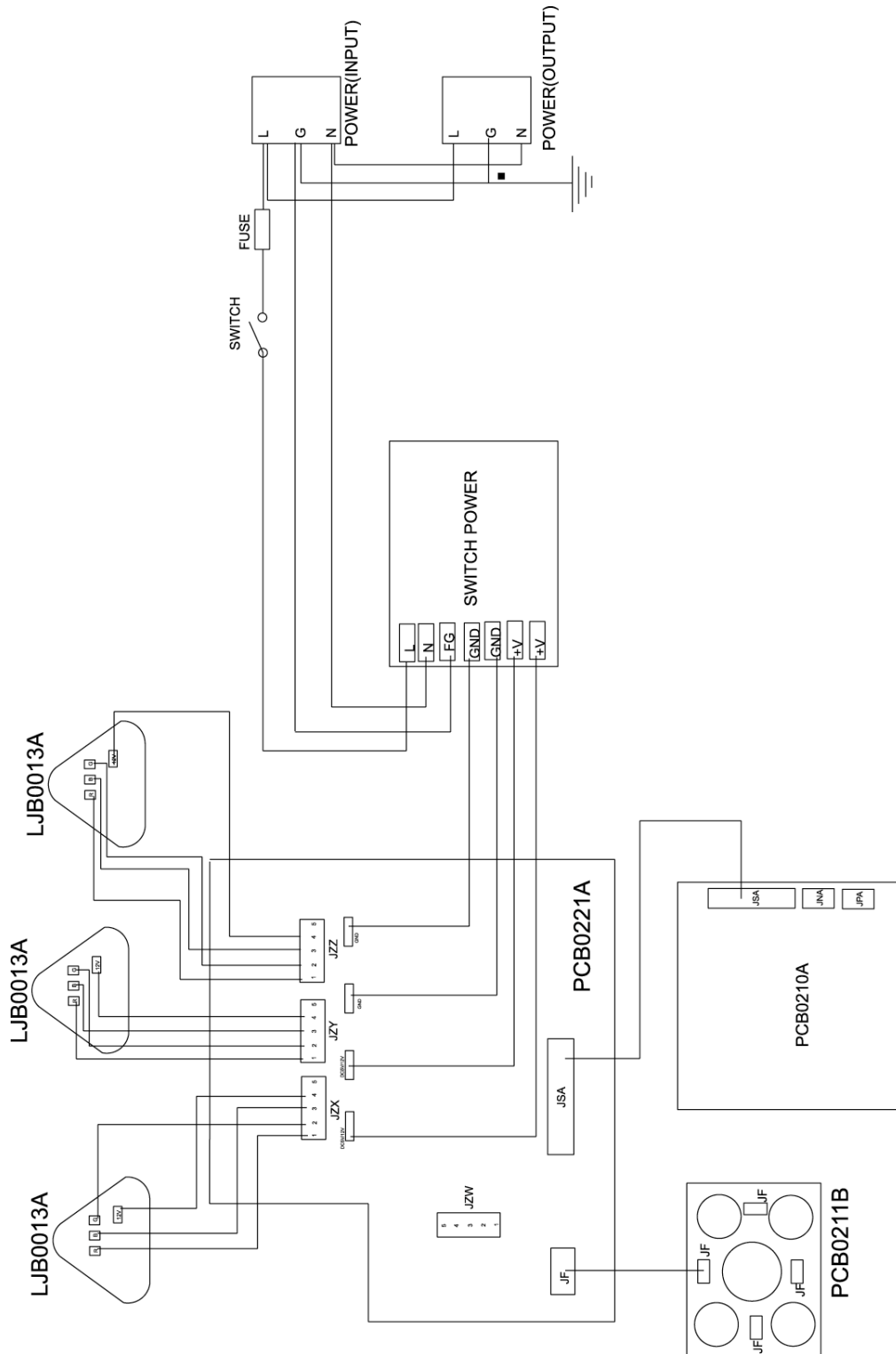

## 17. TECHNICAL SPECIFICATIONS

<i>Power supply:</i>	<i>100v~240v / 50Hz~60Hz AC</i>
<i>Power consumption:</i>	<i>MAXIMUM 65W</i>
<i>LED Configuration:</i>	<i>12 Tri-Color, 1Watt SMDs / 36 1-Watt Total (12 x Red, 12 x Green 12 x Blue)</i>
<i>IP Rating:</i>	<i>IP20</i>
<i>Weight:</i>	<i>4.3 Kgs / 9.5Lbs</i>
<i>DMX Channels:</i>	<i>15, 12, 4, or 3 Channel mode</i>
<i>DMX Drive:</i>	<i>Standard DMX-512, 3 pole XLR; [+] = Pin 3 [-] = Pin 2 [Ground] = Pin 1. 5 pole XLR; [+] = Pin 3 [-] = Pin 2 [Ground] = Pin 1. Pins 4 &amp; 5 are not applicable</i>
<i>Color Mixing:</i>	<i>RGB Color Additive Mixing</i>
<i>Beam Angle:</i>	<i>38.5°</i>
<i>Fuse:</i>	<i>GMA 220v~2A</i>
<i>Dimmer:</i>	<i>Continuous Dimming 0~100%</i>
<i>Strobe:</i>	<i>Electronic Strobe 0~18 Fps</i>
<i>Lamp Life:</i>	<i>100,000 Hours Rated Life</i>
<i>Dimensions:</i>	<i>(41.5 x 23 x 8)cm 16.3" x 9" x 3.15"</i>

***Please Note: Specifications and improvements in the design of this unit and this manual are subject to change without any prior written notice.***

Elation Professional  
6122 S. Eastern Ave.  
Los Angeles, CA. 90040  
323-582-3322 / 323-832-9142 fax  
[www.ElationLighting.com](http://www.ElationLighting.com) /  
[Info@ElationLightng.com](mailto:Info@ElationLightng.com)