

# User's Guide

## for Twin10G™ Thunderbolt Adapter

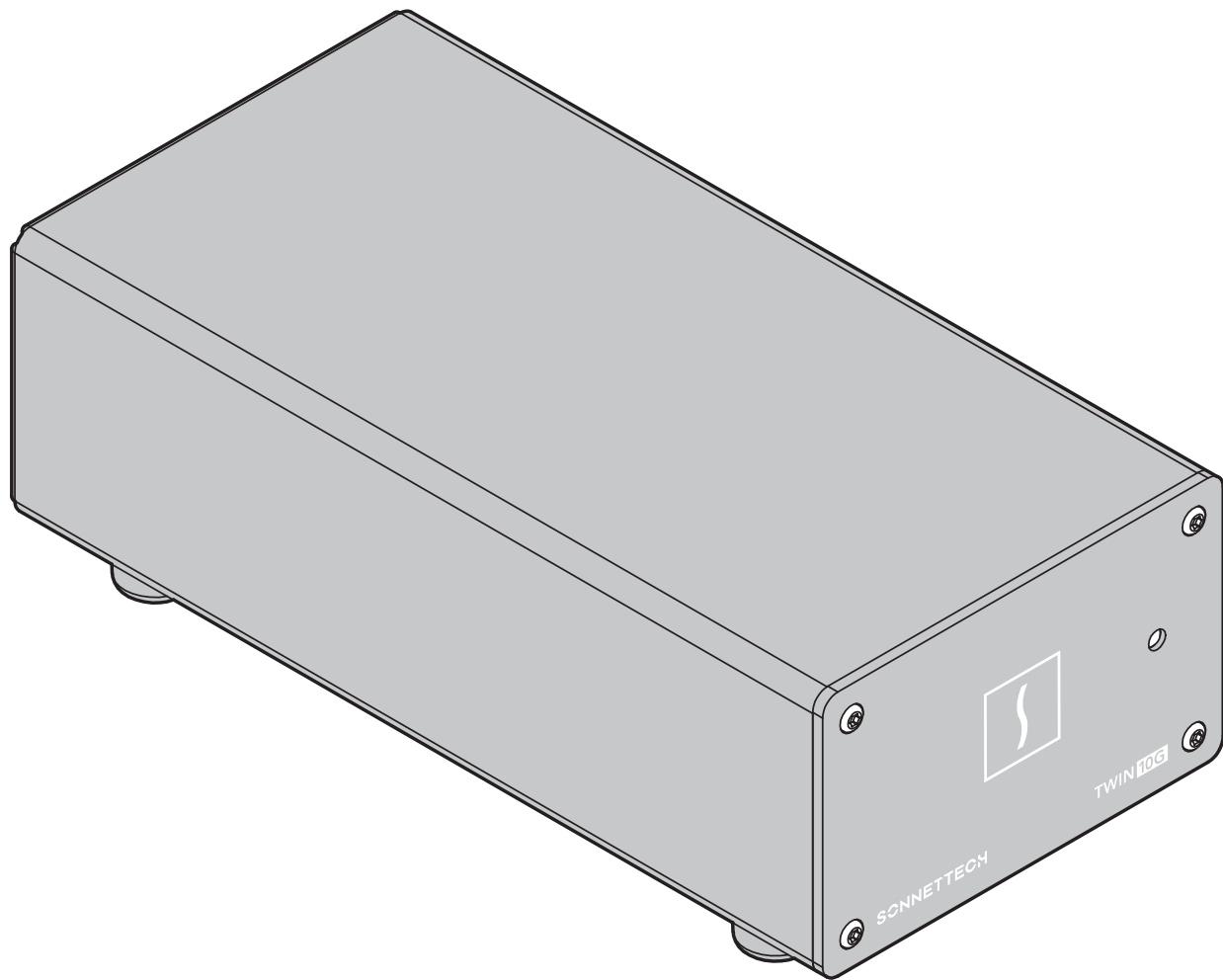

**Support Note:** This document was up to date at the time of printing. However, changes to the hardware or software may have occurred since then. Please check the Sonnet website for the latest documentation.

1. Go to <https://www.sonnettech.com/support/kb/kb.php>
2. Navigate to and click the Twin10G link.
3. Click the Manual link.
4. Click the Twin10G User's Guide [English] link and then check the Document Version information. If the version listed is later than this document (**revision N**), click the Download Now button for the latest version.



For  
Windows



## Contents

<b>1</b>	<b>Chapter 1 – Introduction, System Requirements, and System Preparation</b>	<b>1</b>
	Introduction	
	Mac Compatibility	
	Windows Compatibility	
	Linux Compatibility	
	System Requirements	
	Driver Information	
	Preparing to Use the Adapter With a Mac Computer	
	Preparing to Use the Adapter With a Windows Computer	
	Preparing to Use the Adapter With a Linux Computer	
<b>2</b>	<b>Twin10G Description</b>	<b>3</b>
	Twin10G Indicators, Sockets, and Ports	
	Power Adapter	
	Thunderbolt 3 (40Gbps) Cable	
	Thunderbolt Connector Retainer Clip	
<b>3</b>	<b>Driver Download/Installation Steps</b>	<b>5</b>
	Driver Download and Installation Steps—Mac Users	
	Driver Download and Installation Steps—Windows Users	
<b>4</b>	<b>Twin10G Adapter Connection Steps</b>	<b>6</b>
<b>5</b>	<b>Verification and Configuration Steps</b>	<b>7</b>
	Confirm the Twin10G and Its Ethernet Controllers are Recognized—Mac Users	
	Confirm the Twin10G and Its Ethernet Controllers are Recognized—Windows Users	
	Basic Configuration Steps—Mac Users	
	Performance Tuning Steps—Mac Users	
	Basic Configuration Steps—Windows Users	
<b>6</b>	<b>Tips, General Information, and Known Issues</b>	<b>11</b>
	Tips, General Information	
	Known Issues	
<b>7</b>	<b>Warnings, FCC Compliance, and Support Information</b>	<b>12</b>
	Warnings	
	FCC Compliance	
	Contacting Customer Service	
	Visit Our website	

## Chapter 1 – Introduction, System Requirements, and System Preparation

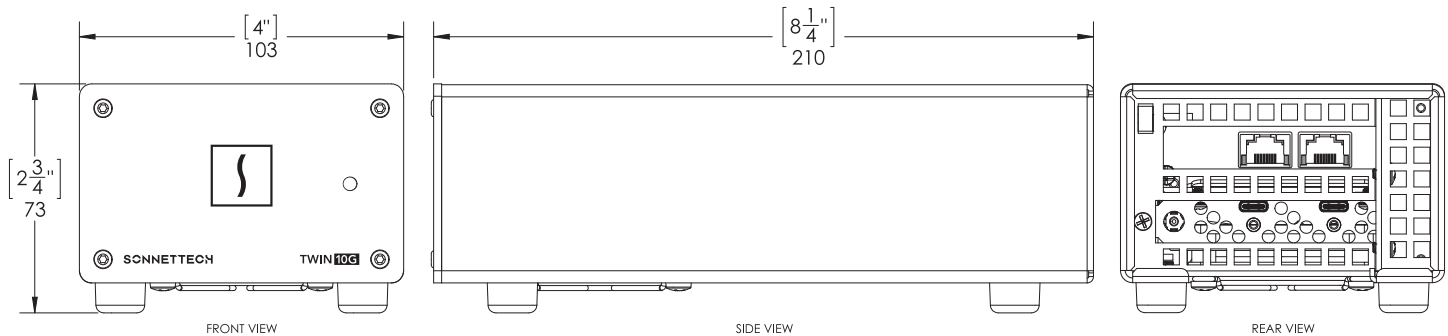

### Introduction

Congratulations on your purchase! The Twin10G is a Thunderbolt 3 to 10 Gigabit Ethernet (10GbE) adapter that enables you to connect your computer with Thunderbolt ports to 10GbE infrastructure.

### Mac® Compatibility

- Mac (M1/M2 series)
- Mac (Intel®) with Thunderbolt 3 ports
- Mac with Thunderbolt 2 when used with an Apple Thunderbolt 3 (USB-C) to Thunderbolt 2 Adapter plus Thunderbolt 2 cable (sold separately)
- macOS® 10.12.6+ (Sonnet recommends macOS 10.13.6+ when connecting via SMB protocol)

### Windows® Compatibility

- Windows computer with Thunderbolt 4 or Thunderbolt 3 ports
- Windows 11, 10

### Linux® Compatibility

- Linux computer with Thunderbolt 4 or Thunderbolt 3 ports
- Linux Kernel 5.4+

### System Requirements

The Twin10G adapter requires the following to operate:

- Thunderbolt (40Gbps) cable (included)
- One or two Cat 6 or Cat 6A cables



**Support Note:** For Windows and Linux link aggregation (teaming) support, the switch or router to which the Twin10G is connected must also support link aggregation, and ports must be configured for link aggregation. Windows 10 teaming is supported with the installation of Intel Advanced Network Services (ANS).

### Driver Information—macOS and Windows

The drivers that enable the Twin10G adapter to work with Mac and Windows computers must be downloaded from Sonnet's website; instructions follow.

### Driver and Configuration Information—Linux

The drivers that enable the Twin10G adapter to work with Linux are installed as part of the Linux Kernel 5.4 and later.

The steps necessary to configure the Sonnet adapter with your computer may vary based on the version of Linux running. Sonnet recommends using whatever method or tools you would normally use for configuring any onboard ports.

## Chapter 1 – Introduction, System Requirements, and System Preparation

### Preparing to Use the Adapter With a Mac Computer

To enable the Twin10G to work with your system, you will do the following:

1. Update your computer to the latest version of macOS; version 10.12.6 or later is required.
2. Download and install the Twin10G drivers (instructions follow); **do not connect the adapter to your computer until this step is completed.**
3. Connect the Twin10G adapter to a switch or storage system (instructions follow).
4. Connect the Twin10G adapter to your computer, and then power on the computer (instructions follow).
5. Confirm the Twin10G adapter and its Ethernet controllers are recognized by your computer (instructions follow).
6. Configure the adapter through the System Preferences' Network control panel (instructions follow).

### Preparing to Use the Adapter With a Windows Computer

To enable the Twin10G to work with your system, you will do the following:

1. Update Windows if necessary; you must use Windows 11, or Windows 10 (64-bit Edition Version 2004 or greater). To check the version number, type *winver* in the search bar and click enter.
2. For computers with Thunderbolt 3 ports, update your computer's BIOS to the latest version. If you need help updating your BIOS, contact your computer manufacturer.
3. For computers with Thunderbolt 3 ports, update your Thunderbolt Bus Driver to the latest version; you will need version 16.3.61.275 or newer. To check your driver version, go to Settings:Apps:Thunderbolt(TM) Software and you will see the version number. If it is not 16.3.61.275 or newer, then you need to update it. Check with your computer manufacturer for an update.
4. Download and install the Twin10G drivers (instructions follow).
5. Connect the Twin10G adapter to a switch or storage system (instructions follow).
6. Connect the Twin10G adapter to your computer, and then approve the device (always connect); instructions follow.
7. Confirm the Twin10G adapter and its Ethernet controllers are recognized by your computer (instructions follow).
8. Configure the adapter through the Network and Sharing Center control panel (instructions follow).

### Preparing to Use the Adapter With a Linux Computer

To enable the Twin10G to work with your system, you will do the following:

1. If necessary, download and install Linux Kernel 5.4 or later.
2. Connect the Twin10G adapter to a switch or storage system.
3. Connect the Twin10G adapter to your computer, and then power on the computer.
4. Configure the adapter using the methods or tools you would normally use for configuring onboard ports.

## Chapter 2 – Twin10G Description

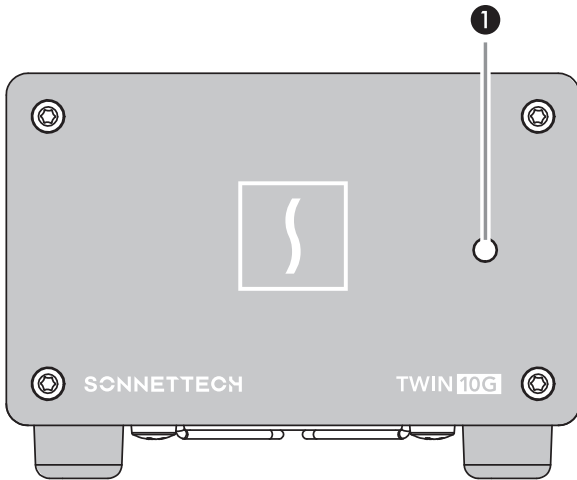

**Support Note:** Sonnet has sold two versions of the Twin10G adapter. The ports are the same on both versions; only the activity and link indicators differ as designated. Some Twin10G adapters shipped with front panels labeled Echo Express SEL.

### Twin10G Indicators, Sockets, and Ports

#### 1 – Power Indicator

This lights when the Twin10G adapter is powered, the Thunderbolt cable between the adapter and your computer is plugged in securely, and the computer powered on. Note that if the Twin10G is connected to another Thunderbolt peripheral device instead of directly to the computer, any other Thunderbolt device connected between the computer and adapter must also be powered on before the adapter's power indicator will light up.

#### 2 – Activity Indicators (Adapter Version 1)

These LEDs flash green to indicate a link is established between the Twin10G adapter and the switch and there is activity between the two.

#### 3 – RJ45 (10GBASE-T) Port 2

Connect a Cat 6 or Cat 6A cable between this port and the switch's or storage device's RJ45 port.

#### 4 – Link Speed Indicators (Adapter Version 1)

When a link is established between the Twin10G adapter and the switch, these LEDs light to indicate the link speed to the switch: yellow = 10Gb, green = 1Gb, off = 100Mb.

#### 5 – RJ45 (10GBASE-T) Port 1

Connect a Cat 6 or Cat 6A cable between this port and the switch's or storage device's RJ45 port.

#### 6 – 12VDC Power Socket

Connect the included DC power adapter between this socket and the included power cord.

#### 7 – Thunderbolt Ports

Connect the included (or comparable) Thunderbolt 3 (40Gbps) cable, or any Thunderbolt 4 cable, between either port and your computer's Thunderbolt port (or other Thunderbolt device in the chain connected to the computer). *You may not connect two computers to this adapter's Thunderbolt ports, nor to a daisy chain of Thunderbolt peripheral devices between computers.* The second port may be used to connect to another Thunderbolt peripheral device, display(s), or USB device (when connected with the proper cable or adapter).

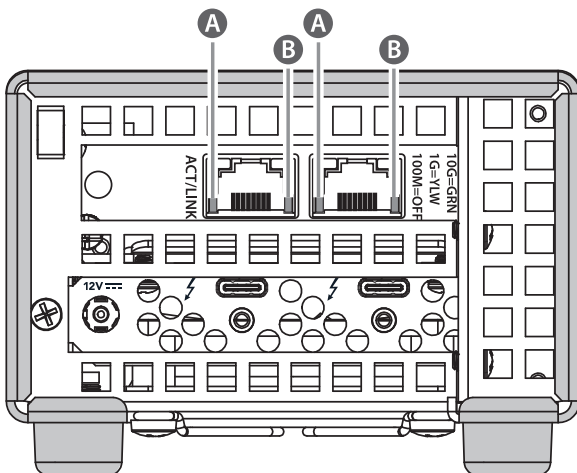
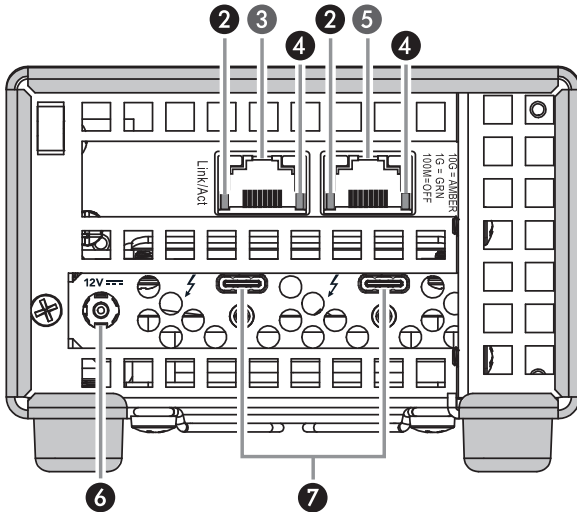

#### A – Activity/Link Indicators (Adapter Version 2)

These LEDs light up green to indicate a link is established between the Twin10G adapter and the switch, and flash green when there is activity between the two.

#### B – Link Speed Indicators (Adapter Version 2)

When a link is established between the Twin10G adapter and the switch, these LEDs light to indicate the link speed to the switch: green = 10Gb, yellow = 1Gb, off = 100Mb.

## Chapter 2 – Twin10G Description

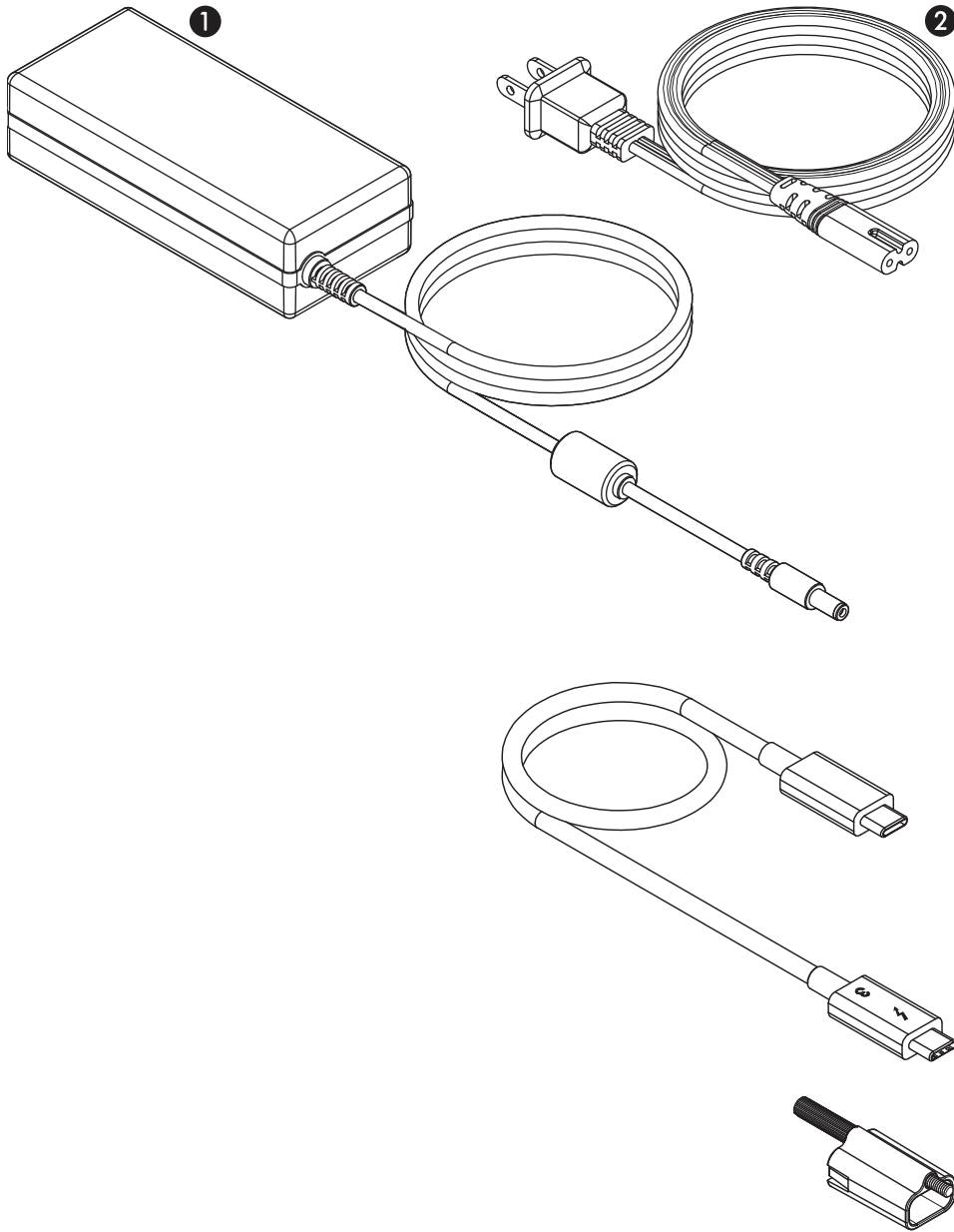

### Power Adapter

#### 1 – Power Adapter

Connect this to the Twin10G adapter's 12VDC socket.

#### 2 – Power Cord

Connect this between a power outlet and the power adapter. Note that the power cord included with your product may appear different than the one pictured here, depending on where the product was purchased.

### Thunderbolt 3 (40Gbps) Cable

Connect this cable between the Twin10G adapter and your computer (or other Thunderbolt device in the chain connected to the computer). Connecting the Twin10G to a computer port marked with a generic USB icon (⚡) or USB + Charging Port icon (⚡) is NOT supported.

### Thunderbolt Connector Retainer Clip

This secures the included Thunderbolt 3 cable's connector plugged into the Twin10G adapter's Thunderbolt port to prevent accidental cable disconnection. This clip is compatible with Sonnet 0.5- and 0.7-meter Thunderbolt 3 cables.

## Chapter 3 – Driver Download/Installation Steps



**WARNING:** Do NOT connect the Twin10G adapter to your computer until *after* you install the Sonnet drivers!

Connecting the adapter before installing the drivers allows an incorrect Apple driver to load, resulting in poor performance.

### Driver Download and Installation Steps—Mac Users

This section describes the download and installation of the drivers required to support the Twin10G adapter connected to your Mac computer.

1. Launch a web browser and go to <https://www.sonnettech.com/support/kb/kb.php>.
2. Navigate to and click the Twin10G link.
3. On the Twin10G page, click the Driver link, and then click the arrow next to driver software for your computer's macOS version to display important information. After reading the information, click the Download Now button; the software will be downloaded.
4. Double-click the .dmg you downloaded; the file will expand and a new window will open.
5. Double-click the SonnetEthernet-10GE.pkg file to launch the driver installer. Follow the on-screen instructions to install the software.
6. For macOS 10.12.6 (Sierra) users, skip to step 8. Otherwise, after you click Install Software, an alert will appear; click Open System Settings, NOT the highlighted OK button; this will open Privacy & Security (or Security & Privacy) in System Settings.

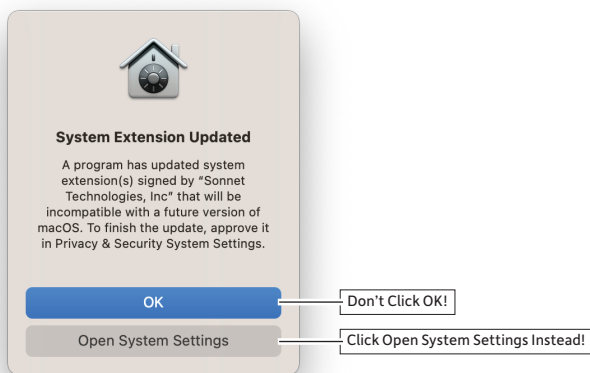

7. In the *Privacy & Security* window, find the statement that *System software from developer "Sonnet Technologies, Inc." has been updated*, and then click the Allow button next to it; another alert will appear.

### 8. For macOS 10.12.6 (Sierra) Users

When the window appears indicating the software installation is complete, click Restart to restart your system and finish the driver installation.

### For macOS 10.13 (High Sierra) and Later Users

In the Privacy & Security alert, enter your password and then click Modify Settings. Another alert will appear instructing you to restart your computer; click Restart to restart your system and finish the driver installation.

### Driver Download and Installation Steps—Windows Users

This section describes the download and installation of the drivers required to support the Twin10G adapter connected to your Windows PC.

1. Launch a web browser and go to [www.sonnettech.com/support/kb/kb.php](http://www.sonnettech.com/support/kb/kb.php)
2. Navigate to and click the Twin10G link.
3. On the Twin10G support page, click the Driver link, and then click the Download Now button next to the driver software for Windows link; a new window or tab will open.
4. On the *Intel® Ethernet Adapter Complete Driver Pack* page, locate and click the Download button; an *Intel Software License Agreement* window will open.
5. Read the license agreement, and then click the "I accept the terms in the license agreement" button; the file will start downloading.
6. Locate the .zip file you downloaded, right-click it and select Extract All, and then follow the instructions; the file will expand and a new window will appear.
7. In the folder that opened in the new window, locate and double-click Autorun; an *Intel Network Connections* window will open.
8. In the *Intel Network Connections* window, click Install Drivers and Software; a pop-up window will appear asking for your permission for the application to make changes to your device. Click Yes; the installer will launch.
9. Follow the on-screen instructions to complete the driver installation.

## Chapter 4 – Twin10G Adapter Connection Steps



**Support Note:** Sonnet's ThunderLok™ 3 Thunderbolt connector retainer clip secures the included Thunderbolt 3 (40Gbps) cable to the Twin10G adapter to prevent accidental disconnects. It is compatible with Sonnet 0.7- and 0.5-meter Thunderbolt 3 (40Gbps) cables.

To attach the clip to the cable, remove both from their packaging, and then insert the connector through the connector clip as shown (Figure 1). Note that the connector will pass all the way through the clip; when you connect the cable to the chassis, the clip will secure the connector.

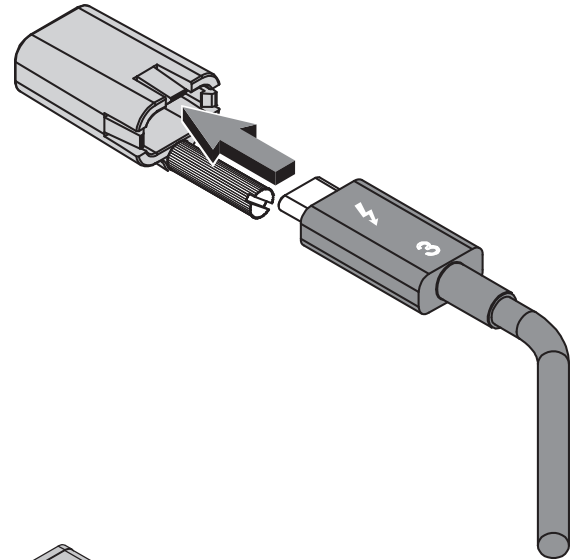

Figure 1

1. Connect the included (or comparable) Thunderbolt 3 (40Gbps) cable, or any Thunderbolt 4 cable, between a Thunderbolt port on the Twin10G adapter and a Thunderbolt port on your computer, or other Thunderbolt device in the chain connected to the computer (Figure 2). Note that cables or computer ports marked with a generic USB icon (🔌) or USB + Charging Port icon (🔌⚡) are NOT compatible. Secure the retainer clip to the threaded hole beneath the Thunderbolt port on Twin10G if you attached it.

If you are daisy chaining additional Thunderbolt devices, connect another Thunderbolt cable between the downstream device and the open Thunderbolt port on the Twin10G. Also note that you may not connect two computers to the Sonnet adapter's Thunderbolt ports, nor to a daisy chain of Thunderbolt devices between computers.



**Support Note:** Unless your setup requires connection redundancy or link aggregation (and your switch or storage system supports those features), connecting the Twin10G adapter to a switch or storage system requires only a single Cat 6 or Cat 6A cable.

2. Connect one or two Cat 6 or Cat 6A cable(s) between the port(s) on the Twin10G adapter and the port(s) on the switch or storage device.
3. Connect the included power cord between a wall outlet or power strip and the power adapter; verify the connector is plugged in securely. Note that the power adapter's power indicator will light at this time.
4. Connect the power adapter cable to the Twin10G adapter's 12V power socket.
5. Go to the next section, Verification and Configuration Steps.

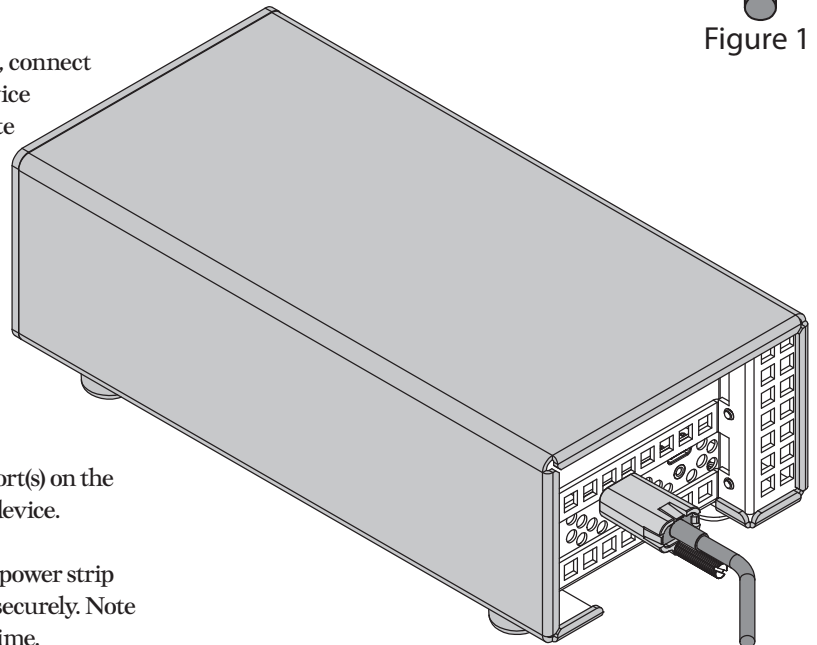

Figure 2



## Chapter 5 – Verification and Configuration Steps

### Confirm the Twin10G and Its Ethernet Controllers Are Recognized—Mac Users

This page instructs Mac users how to verify the Twin10G is recognized by the computer; Windows users should skip to the next page.

1. With the Twin10G adapter powered and connected to the computer, turn on the computer.
2. From the Apple menu, select About This Mac; the *About This Mac* window will open.
3. In the *About This Mac* window click System Report; a full report window will open.
4. In the *System Information* window, click Thunderbolt (or Thunderbolt/USB4) under the Hardware header in the left column (Figure 3).
5. In the top right column under the Thunderbolt Device Tree (or Thunderbolt/USB4 Device Tree) header, you will see the computer, followed by Thunderbolt Bus, and then “Echo Express SEL TB3” (Figure 3).

 **Support Note:** If you do not see “Echo Express SEL TB3” listed, disconnect and reconnect the Thunderbolt cable between the computer and Twin10G adapter. Note that it is not necessary to shut down the computer before disconnecting and reconnecting the cable.

6. In the *System Information* window click PCI under the Hardware header in the left column (Figure 4).
7. At the top of the right column, the installed card is listed. You should see “Yes” next to Driver Installed and Tunnel Compatible, otherwise the card or driver may not be Thunderbolt-compatible (Figure 4).
8. Skip to the next section, Basic Configuration Steps—Mac Users.

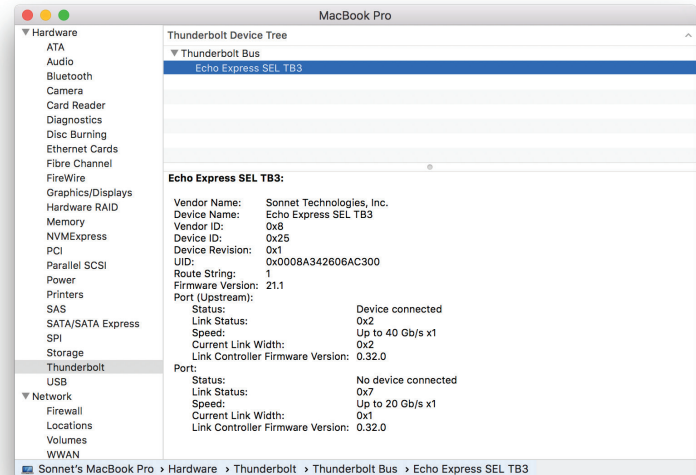

Figure 3

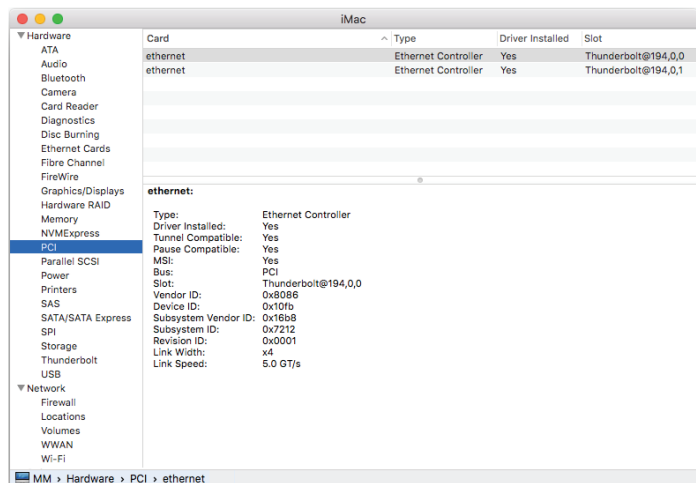

Figure 4

## Chapter 5 – Verification and Configuration Steps

### Confirm the Twin10G and Its Ethernet Controllers Are Recognized—Windows Users

This section describes how to confirm the Twin10G adapter is recognized by your Windows computer.

1. With the Twin10G adapter connected to a power source and to the computer, turn on the computer.
2. When the computer boots for the first time after connecting the Twin10G adapter, a *New Thunderbolt™ Devices Attached...* window appears (Figure 5). Select Always Connect from the drop-down menu.
3. From the Windows Start menu, select the Windows Settings (gear) icon; the *Windows Settings* window will appear.
4. In the *Windows Settings* window, click on the Network & Internet Link; the *Network Status* window will appear. Click the Ethernet link on the left; the *Ethernet* window will appear.
5. In the *Ethernet* window, the various Ethernet ports recognized by the system are listed to the right. For most users, the Twin10G adapter's will be the only other Ethernet ports listed, with the computer's onboard Ethernet port listed as "Network". Click on one of the other ports; an Ethernet port *Properties* window will appear. Each of the Sonnet adapter's ports will have the description "Intel Ethernet Controller X540" or "Intel Ethernet Controller X550" with either #1 or #2 listed next to it.
6. Skip to the next section, Basic Configuration Steps—Windows Users.



Figure 5

## Chapter 5 – Verification and Configuration Steps

### Basic Configuration Steps—Mac Users

Listed below are the basic steps necessary to configure the Twin10G adapter for use with your computer.

1. With the Twin10G adapter connected to your computer and 10GbE infrastructure, open System Preferences, and then click Network.
2. In the Network system preferences panel, click one of the Twin10G adapter's ports (identified as Thunderbolt Ethernet Slot x, Port 1 and Thunderbolt Ethernet Slot x, Port 2) in the left panel, and then configure the settings; repeat for the other port if necessary (Figure 6).
3. When you've completed reviewing or changing the settings, click Apply.

### Performance Tuning Steps—Mac Users

Listed below are steps required to configure the Twin10G adapter for maximum performance.



**Support Note:** In order to realize any performance increases, the network switches and server to which the Sonnet adapter is connected must all be configured to have jumbo frames enabled.

1. With the Twin10G adapter connected to your computer and 10GbE infrastructure, open System Preferences, and then click Network.
2. In the Network System Preferences panel, click one of the Twin10G adapter's ports (identified as Thunderbolt Ethernet Slot x, Port 1 and Thunderbolt Ethernet Slot x, Port 2) in the left panel, and then click Advanced; a new panel appears.
3. In the Advanced panel, click Hardware. From the Configure drop-down menu, select "Manually". In the Speed drop-down menu, leave the setting at 10G... In the Duplex drop-down menu, select "full-duplex" (*not* "full duplex, flow-control"). In the MTU drop-down menu, select "Custom," and then enter "9000" in the box below (Figure 7).
4. When you've completed changing the settings for the port, click OK.
5. Repeat steps 2–4 for the other port, if necessary.
6. Back in the main Network window, click Apply after you've completed changing the settings.
7. If you do not need to combine Ethernet ports (link aggregation), your installation is complete. For additional information on combining Ethernet ports, open a web browser and go to [support.apple.com](https://support.apple.com); type "network, Ethernet" and "Manage Virtual interfaces" to display various articles.

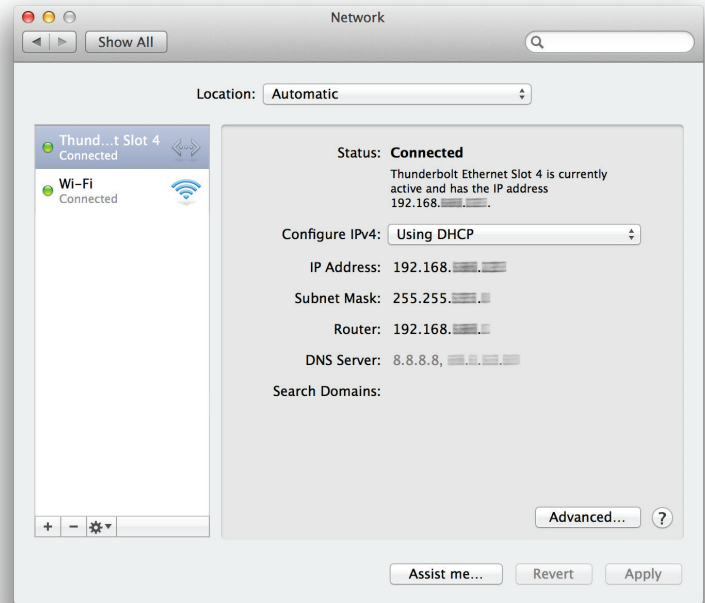

Figure 6

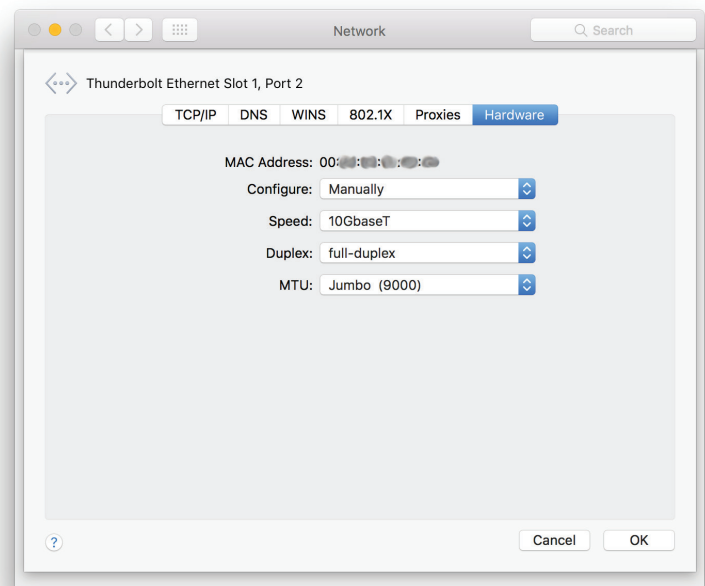

Figure 7

## Chapter 5 – Verification and Configuration Steps

### Basic Configuration Steps—Windows Users

Listed below are the basic steps necessary to configure the Twin10G adapter for use with your computer.

1. With the Twin10G adapter connected to your computer and 10GbE infrastructure, open the Network and Sharing Center control panel (Figure 8).
2. Set up network connections by clicking “Set up a new connection or network”.

You may also configure the Sonnet adapter’s settings using Windows Device Manager. You may locate the device’s ports in the Network adapters Category, listed as Intel Ethernet Controller X540 (or X550) dual port network connections.

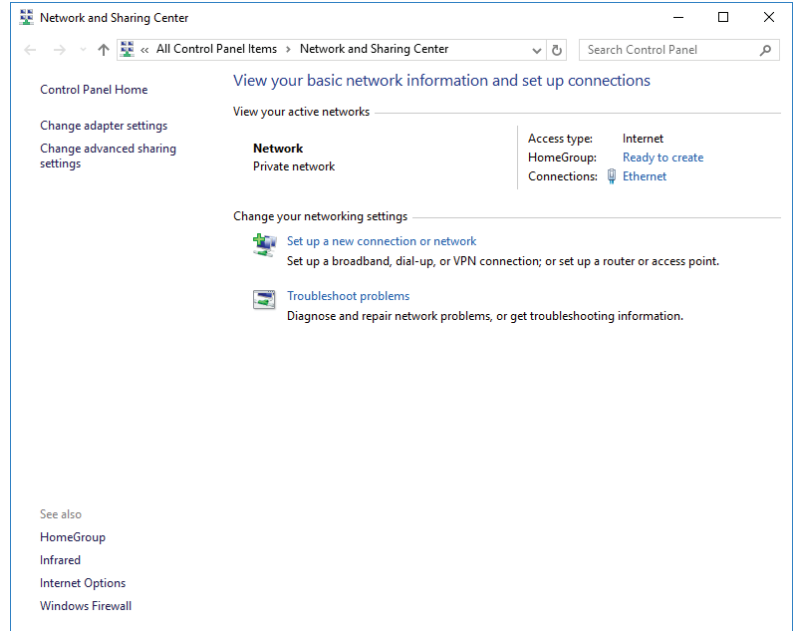

Figure 8

## Chapter 6 – Tips, General Information, and Known Issues

### TIPS, GENERAL INFORMATION

#### Keeping the Twin10G Adapter Cool

With its optimized airflow design and automatic, temperature-controlled fan providing cooling at all times, the Sonnet adapter provides adequate cooling for the components inside. *Do not block the fan or any of the vents while the adapter is operating!* Otherwise, the adapter may overheat.

#### Hot-Plugging the Twin10G Adapter

You may connect and disconnect the Thunderbolt cable between the Twin10G adapter and your computer while your computer is on.

#### There's No Need to Unplug the Power Adapter

Because the Twin10G adapter automatically powers on and off with the computer to which it's connected, there's no power switch, nor is there any need to disconnect the power cable under normal use. When your computer is sleeping, the Twin10G enters a low-power state; this allows it to wake with your computer.

#### Power Indicator LED Operation

Because the Twin10G adapter automatically powers on and off with the computer to which it's connected, its power indicator only lights when the computer is on, and turns off when the computer is sleeping or powered off.

#### Connecting Additional Thunderbolt Peripheral Devices

The Twin10G adapter includes two Thunderbolt ports; the first connects it to your computer, while the second supports daisy-chaining of up to five additional Thunderbolt peripheral devices.

#### Twin10G Can Provide Up to 15 Watts of Upstream Power

The Twin10G adapter can provide up to 15 watts to bus-powered Thunderbolt 3 peripheral devices, enabling them to operate without connecting an additional power adapter.

#### How to Identify Thunderbolt 3 (40Gbps) Cables

Look for the Thunderbolt icon (⚡) AND the number 3 on the connector housings to identify these cables. Aside from Thunderbolt cables from Apple, USB-C cables with connectors that only have the Thunderbolt icon without the number 3 may only support 20Gbps speeds, and are not recommended for use with the Echo module. Cables marked with a generic USB icon (🔌) are NOT compatible for connecting the Echo module to the computer.

#### Using the Twin10G Adapter to Charge Your Notebook or Laptop Computer

MacBook Air® and MacBook Pro® with Thunderbolt ports, some PC laptop computers with Thunderbolt 3 ports, and all notebooks and laptops with Thunderbolt 4 ports may be charged *slowly* via the Twin10G adapter's Thunderbolt port (via 15W Power Delivery). Computers with Thunderbolt 2 or Thunderbolt ports cannot be charged via Thunderbolt.

#### Thunderbolt 4 Cable Compatibility

You may use Thunderbolt 4 cables with Thunderbolt 4 or Thunderbolt 3 computers and peripherals without any compromise in performance or functionality.

### KNOWN ISSUES

#### Not All Computers' Thunderbolt Performance is Equal

When using the dock with the 2017 MacBook Pro 13-inch model with four Thunderbolt 3 ports, you should connect the dock to one of the ports on the left side of the computer. The right side ports use an x2 (2-lane) implementation of Thunderbolt 3 that limits PCIe bandwidth to 20Gbps (up to 1,400 MB/s). Some Windows computers equipped with Thunderbolt 3 also use the x2 PCIe lane implementation.

#### Not All Thunderbolt Cables Deliver Full Performance

Full performance from the Twin10G adapter requires the use of the included (or comparable) Thunderbolt 3 (40Gbps) cable, or any Thunderbolt 4 cable. When shopping for a Thunderbolt 3 cable, please be aware that some support only lower data transfer speeds (20Gbps).

#### Operating System (OS) Updates May Break Compatibility

*Specific device drivers that work under one OS version may not work under a later version. Before updating your computer to the latest OS, we recommend that you check Sonnet's support pages to verify that the existing drivers work. Note that other software updates for the computer may also break compatibility.*

#### Some Devices' Performance May be Affected by Where They Are Connected in a Thunderbolt Chain

However small, Thunderbolt introduces latency to a device chain. If you add additional Thunderbolt devices to the chain, you may need to experiment with positioning devices closer to or farther from the computer in the chain.

## Chapter 7 – Warnings, FCC Compliance, and Support Information

### Warnings

- Do not attempt to modify the enclosure. If this device appears to be malfunctioning, contact your reseller or local distributor.
- Do not expose the device to rain, use it near water or containers that contain liquids which might spill into any openings, or in damp or wet conditions.
- Do not drop the Twin10G; dropping or mishandling the Sonnet adapter may result in a malfunction leaving the product inoperable.
- Follow the instructions in this manual carefully; contact your reseller or local distributor for additional advice not covered in this User's Guide.
- If unusual smells, sounds, or smoke come from the device, or if liquids enter it, switch it off immediately and unplug it from the electrical outlet.

### FCC Compliance

Twin10G complies with Part 15 of the FCC Rules. Operation is subject to the following two conditions: This device may not cause harmful interference, AND this device must accept any interference received, including interference that may cause undesired operation.

### Contacting Customer Service

The Sonnet web site located at [www.sonnettech.com](http://www.sonnettech.com) has the most current support information and technical updates. Before contacting Customer Service, please check our web site for the latest updates and online support files, and check this User's Guide for helpful information.

Email support requests generally receive the fastest responses, and are usually processed within a 24-hour period during normal business hours, excluding holidays. When you contact Customer Service, have the following information available so the customer service staff can better assist you:

- Product name
- Computer model
- OS version
- Driver software version
- A System Report (macOS) or a Microsoft System Information MSINFO32 (Windows) report (Windows), along with a description of the issue(s) you are encountering with your device

If further assistance is needed, please contact **Sonnet Customer Service** at:

E-mail: [support@sonnettech.com](mailto:support@sonnettech.com)

Tel: 1-949-472-2772

(Monday–Friday, 9 a.m.–5 p.m. Pacific Time, excluding holidays)

#### Japan Customers

Contact Sonnet Customer Service Japan at:

E-mail: [jp.support@sonnettech.com](mailto:jp.support@sonnettech.com)