

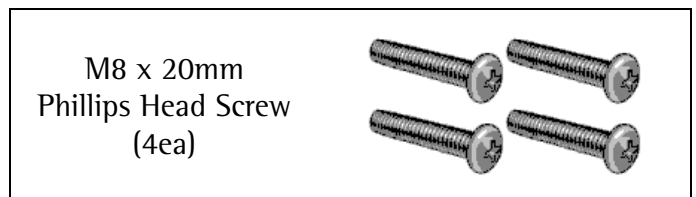

CTM-650 Flat-Panel Adapter Installation Instructions

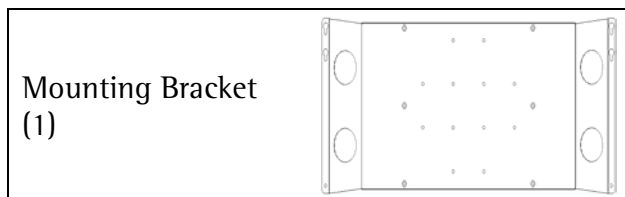

1. Lay the display, screen-down, on a soft and flat surface.
2. Loosely install four (4) M8 x 20mm in the location where the top two mounting holes are located on the bracket. Turn the screws a full 7 rotations.
3. Find the six mounting points that are located on the back of the display (Figure 1).
3. To install the bracket to the display secure the bracket with four (4) M8 x 20mm Phillip Head screws. Do not over tighten the screws (Figure 2).
4. Raise the display with the bracket attached and attach the assembly to the display mount.

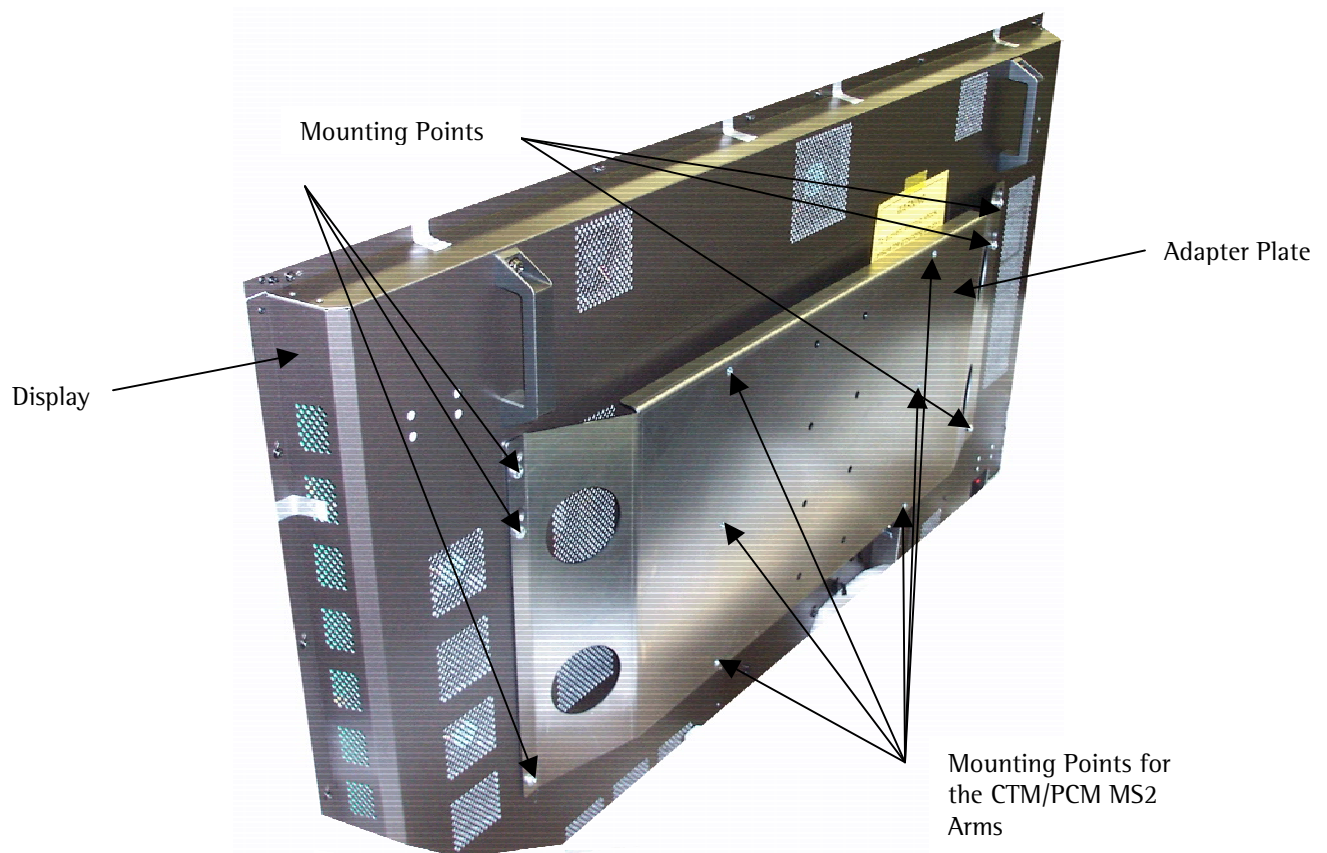

Figure 1. Display Mounting Points

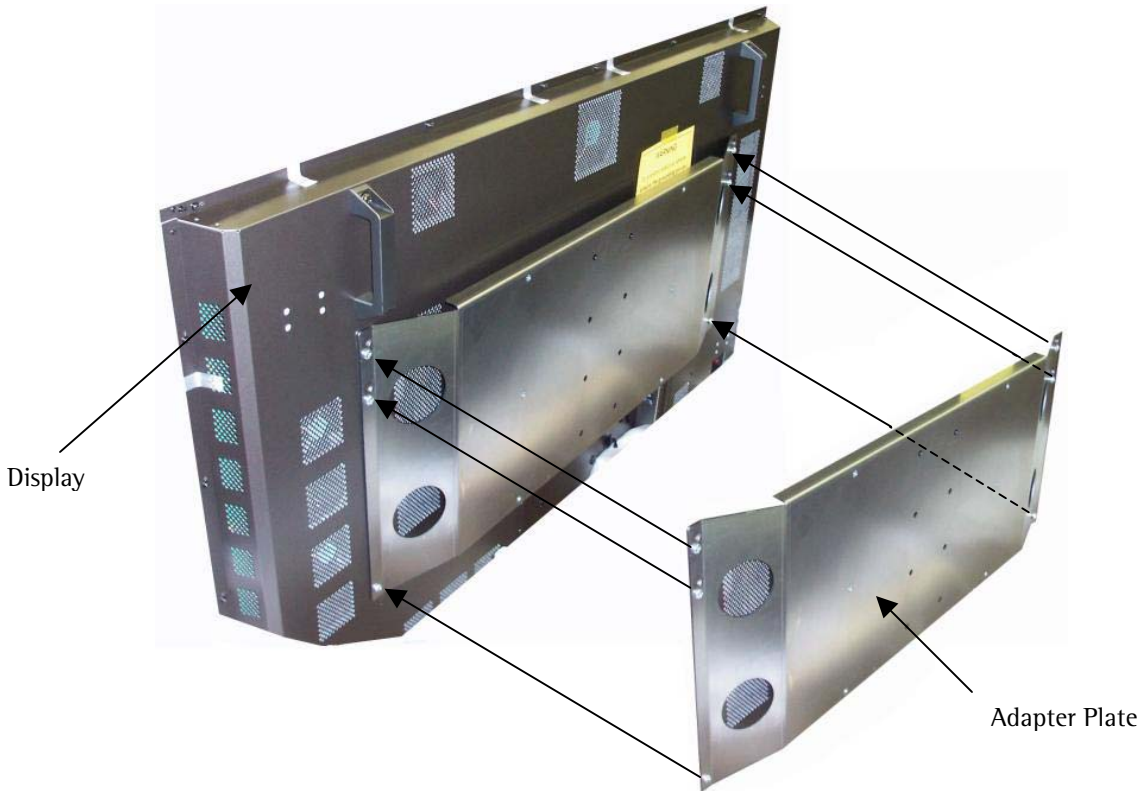

Figure 2. CTM-650 Installation

Floor Stand Installation

1. Secure the PSD-SPA to the adapter plate (Figure 3).
2. Install the adapter plate with the PSD-SPA adapters attached and slide the adapter through the poles and secure to the desired height by tightening the M8 x 10mm Hex Head Screws.
3. Raise the display and insert the head of the screw through the keyholes.
4. Secure the two (2) M8 x 20mm to the bottom of the display and secure all the hardware.

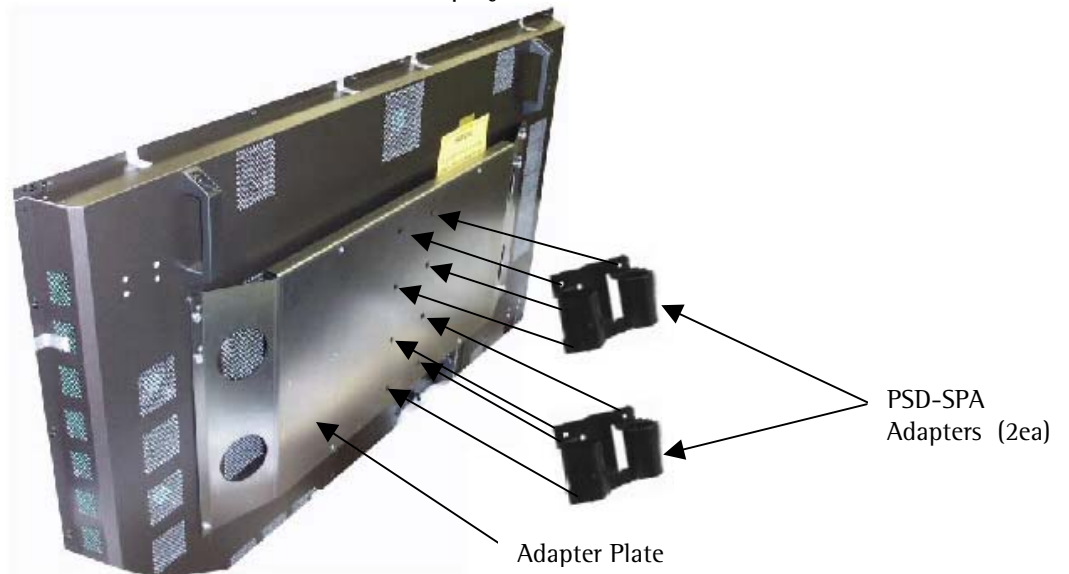

Figure 3. Floor Stand Installation