



Specs

Block Diagram

Warning

Warranty

Specs

Controls

Passive/Active: Use this push-button switch to change from passive to active mode. If your bass is active it can have a hotter signal making the amp to distort early (feel free to use if such additional distortion is desired).

Microtubes: Use this push button to turn on or off the Microtubes Engine to add natural compression, organic harmonic enhancement, and saturation ranging from mild overdrive to high gain bass rage. The Microtubes Engine operates before the 6 band EQ section (you can therefore use the 6 Band Active EQ for additional tone shaping in addition to the Tone knob described below).

Compression: This knob controls the amount of dynamic compression added to the Microtubes Engine. The make up gain is adjusted automatically. The compression can be turn off or assigned using the Darkglass Suite for each mode separately (Clean, B3K, and VMT).

Drive: This knob controls the amount of distortion that the Microtubes Engine will deliver. It will change from a soft warm overdrive to a massive modern distortion sound.

Tone: This knob controls the high harmonic content of the Microtubes

Engine via a variable low pass filter: crank it up for additional attack and definition or dim it down for a smoother sound, especially handy if already running bright clean EQ setting or cabinets with tweeters.

Level: Use this knob to control Microtubes Engine's output volume.

Blend: Use this knob to mix between the Clean signal and the Distortion signal (Microtubes Engine).

B3K/VMT: This push-button switch selects between two overdrive voicings: B3K® mode will deliver an aggressive, percussive sound while the VMT will bring up the mids for a warmer, more neutral character.

Bass: +12dB at 80Hz. Use this slider to change the low-end content of the signal.

Mids: +12dB at 250, 500, 1.5k and 3kHz. These sliders control the mid content of the signal.

Treble: +12dB at 5kHz. Use this slider to change the high content of the signal.

Master: Use this knob to control the overall volume of the amplifier.

Mute: Use this push button to mute the amplifier.

Technical Specifications

Input Impedance: 1M Ω

Minimum Load Impedance: 3 Ω

Maximum Power Output: 500 W RMS @ 4 Ω
250 W RMS @ 8 Ω

Power Amp Input Impedance: 1M Ω

Power Amp Input Level: 2400 mV RMS

Pre-Amp Output Impedance: 1k Ω

Pre-Amp Output Level: 2400 mV RMS

Maximum Power Consumption: approx. 700VA

Forced-air cooled

AC Input Power: 100-120/210-250 VAC (using selector switch on left side panel).

Cycles: 50/60 Hz

Dimensions

Width: 18 cm / 7.1"

Length: 23 cm / 9.1"

Height: 7.1 cm / 2.8"

Weight: 2.4 kg / 5,29 lb

Block Diagram

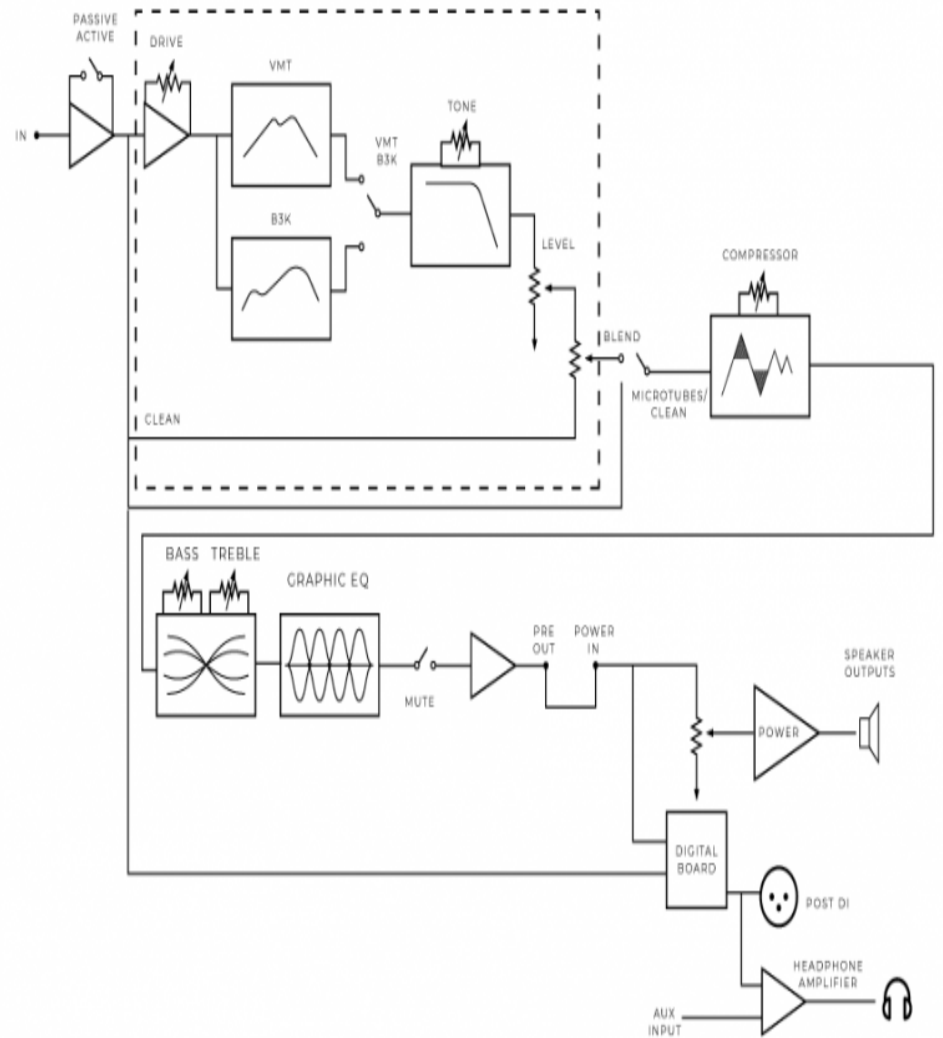

Warning

- There are no user-serviceable parts inside the amplifier. Do not open the amp.
- Never use the amp in a high moisture environment or near liquids.
- The Microtubes 500v2 can deliver more than 115 dB of power. Exposure

to this level of sound can damage your hearing. Always use proper hearing protection when exposed.

- The Microtubes 500v2 can deliver more than 500 Watts. Be sure that your speaker cabinet is able to deliver that power.
- Do not cover the vent holes. The fan and vent holes are part of the cooling system of the amp. Covering the vent holes can lead to overheating and damage to the amplifier.
- Do not use an instrument cable as speaker cable. An instrument cable is not designed to deliver the type of power sent from the amplifier to the speaker.

Troubleshooting

- The button controls do not react: check if the footswitch is connected. If you do not want to use the footswitch, you have to unplug the cable from the rear panel of the amp.
- The amp does not turn on: check if the power cable is connected and if you have power from the wall.
- The sound is low: check your speaker cable. Never use an instrument cable.
- The sound is distorted or too high: check if the passive/active switch matches your bass.

Warranty

Please register for your warranty at <http://mypedal.darkglass.com>. The Microtubes 500v2 is under warranty to the original owner for a period of two years against manufacturing defects in the country where the product was originally purchased.

If you experience a problem with the unit, please contact support@darkglass.com to receive a Return Authorization number or for information on the nearest authorized repair center. A copy of your original receipt must be included with all warranty repairs. You are responsible for all shipping charges. The unit must be shipped to us freight prepaid. We will return the unit freight collect.

Darkglass Electronics Oy is not responsible for shipping damage either to or from our service center. Claims must be filed with the carrier. For repairs please contact your local dealer or distributor for your country's specific warranty period and repair procedures.

Darkglass®, Microtubes® and B3K® are registered trademarks of Darkglass Electronics Oy.



PRIVACY POLICYCAREERS

DARKGLASS is a registered trademark in the U.S., number 4,616,801, owned by Darkglass Electronics Oy.

Designed by Revolve Studio