



A310-FM

Installation Guide

User guide for the A310-FM flush mount tray accessory for Shure MXA310 table array microphones.
Version: 2.2 (2023-E)

Table of Contents

A310-FM Installation Guide	3	Installation Process	4
Installing the Flush Mount	3	Dimensions	8
		Certifications	9

A310-FM Installation Guide

Installing the Flush Mount

The tube and wing nut required to install the rack tray are included with the MXA310 microphone. Refer to the MXA310 user guide for replacement part information.

Tip: This process assumes that both ends of the network cable are accessible. If the other end of the network cable is not accessible, before installing the tube and plugging in the microphone (step 2), you must guide the cable through the hardware components in the following order:

1. Wing nut (see image for correct orientation)
2. Bracket (under table)
3. Table
4. Tray (above table)

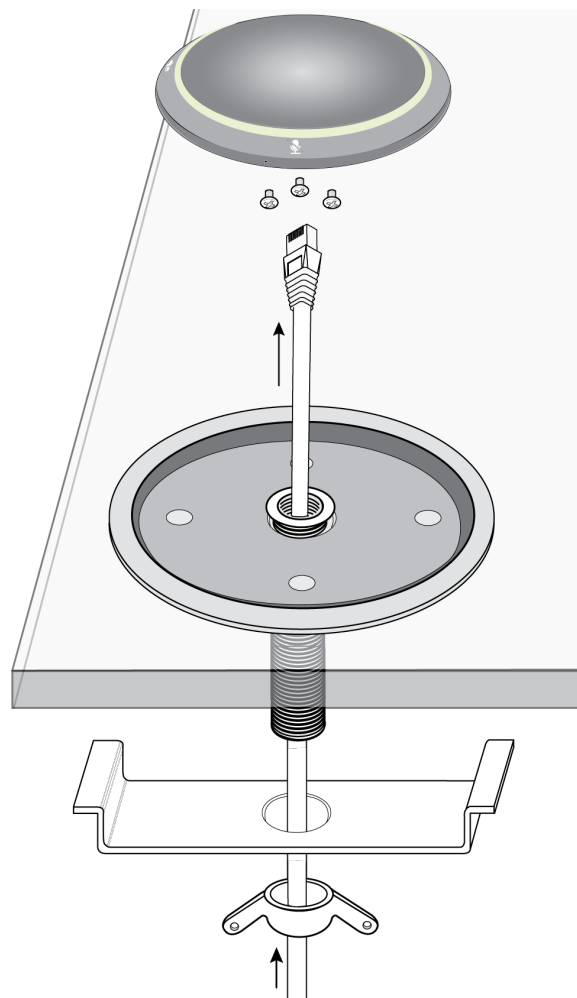

Installation Process

1. Remove the 3 screws located in the center on the bottom of the microphone.

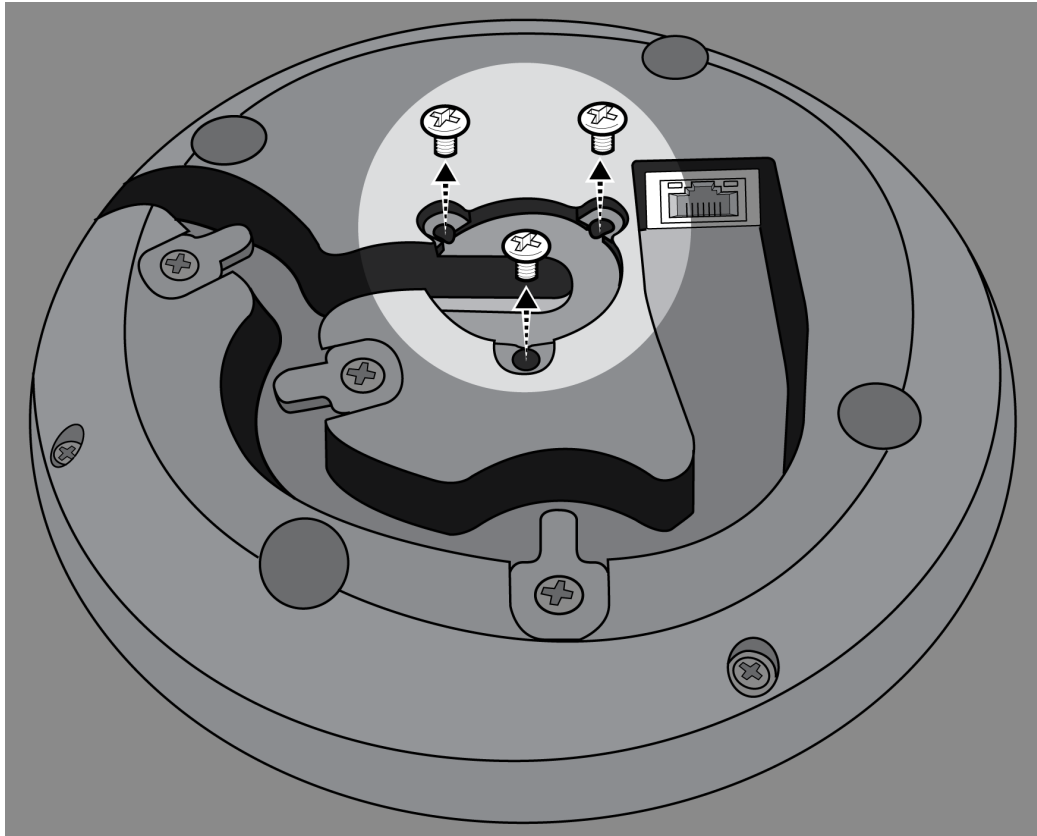

2. Plug a network cable into the microphone and guide it through the center exit path. When the cable is secured, guide it through the tube.

Note: If necessary, remove the retaining tabs to install thicker cable. Replace them after the cable is installed.

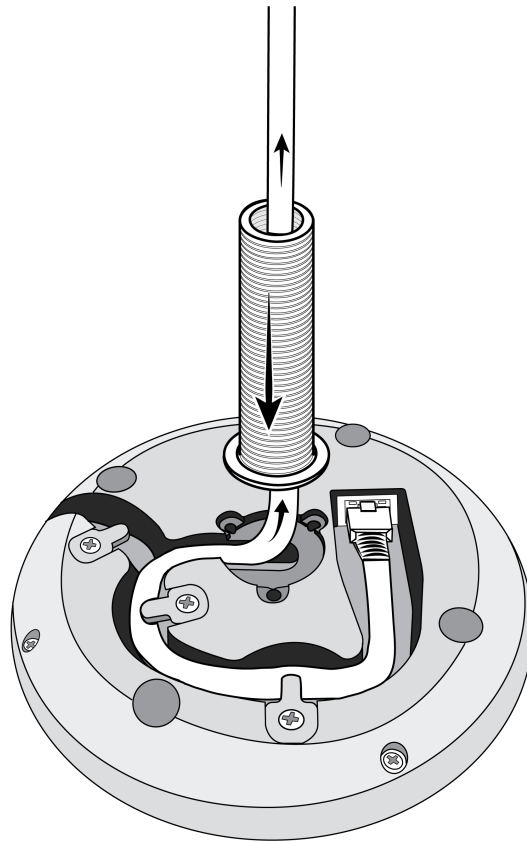

3. Align the tube into the recessed area in the center of the microphone. Install the 3 screws that you removed in step 1 to secure the tube.

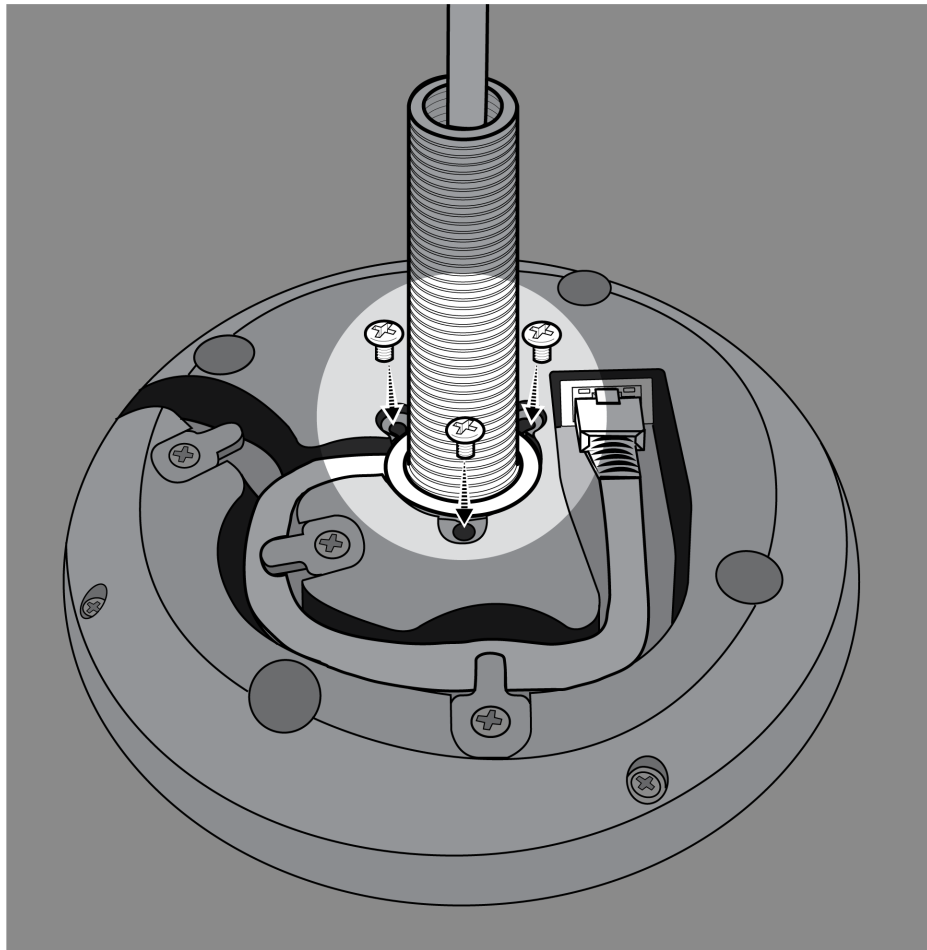

4. Drill a 143 mm (5 5/8 in.) hole through the table, and then place the tray into the hole.

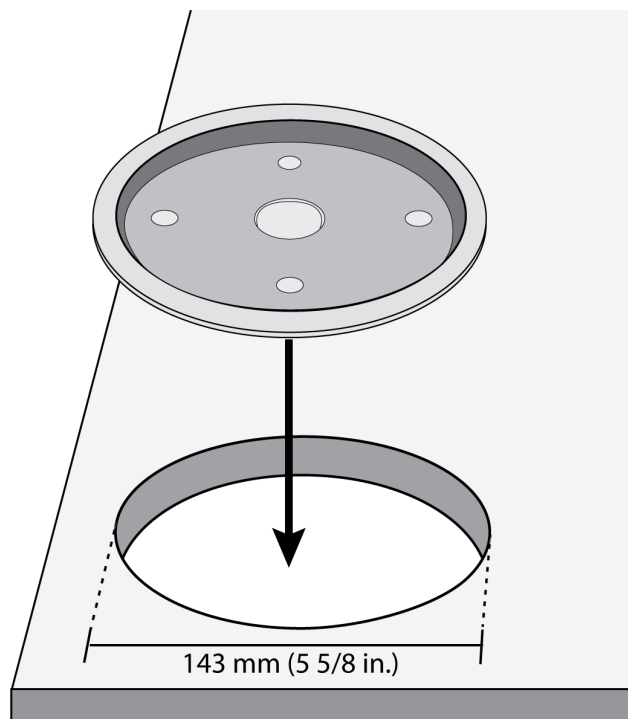

5. Guide the cable through the hole in the center of the tray. Then, place the tube through the hole in the table and gently press the microphone into the tray. Align the Shure logo on the microphone with the Shure logo on the tray. The 4 rubber feet on the bottom of the microphone fit into the 4 smaller holes in the tray.

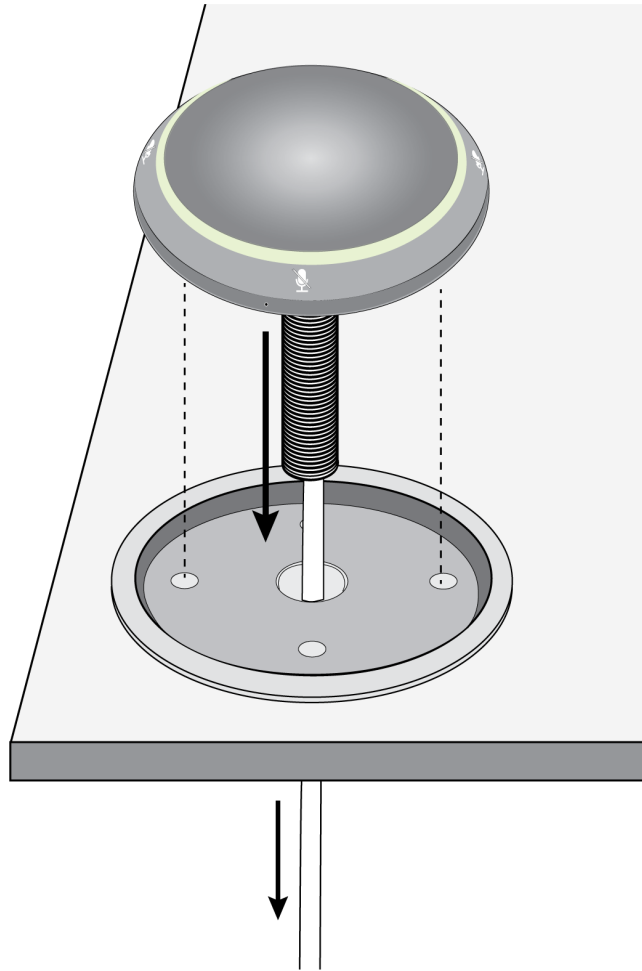

6. Place the bracket underneath the table, with the tube going through the hole. For thicker tables (≥ 55 mm), turn the bracket upside down for additional clearance.

Note: Maximum table thickness = 73 mm (2.87 in)

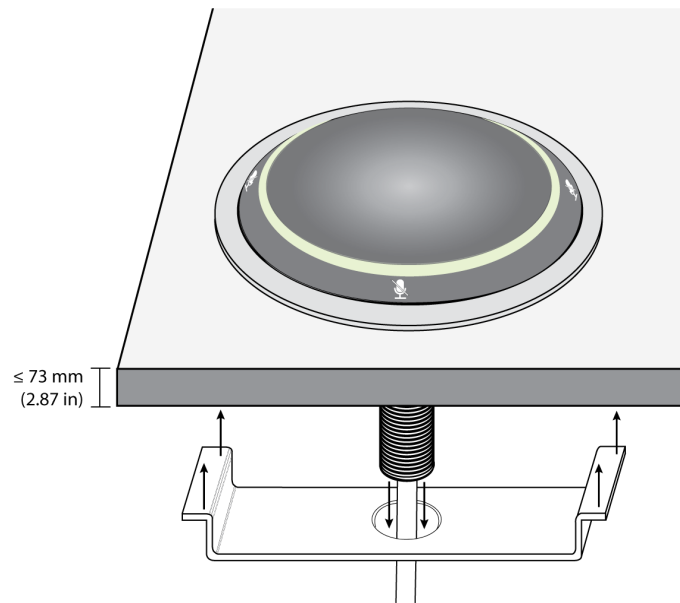

7. Guide the cable through the wing nut, and attach the wing nut onto the tube from underneath the table. Then, hand tighten the wing nut to secure the bracket against the table. Do not overtighten or exceed this torque value: 12.5 kgf·cm.

Optional: Use the hole in the wing nut to insert a cable tie for cable management.

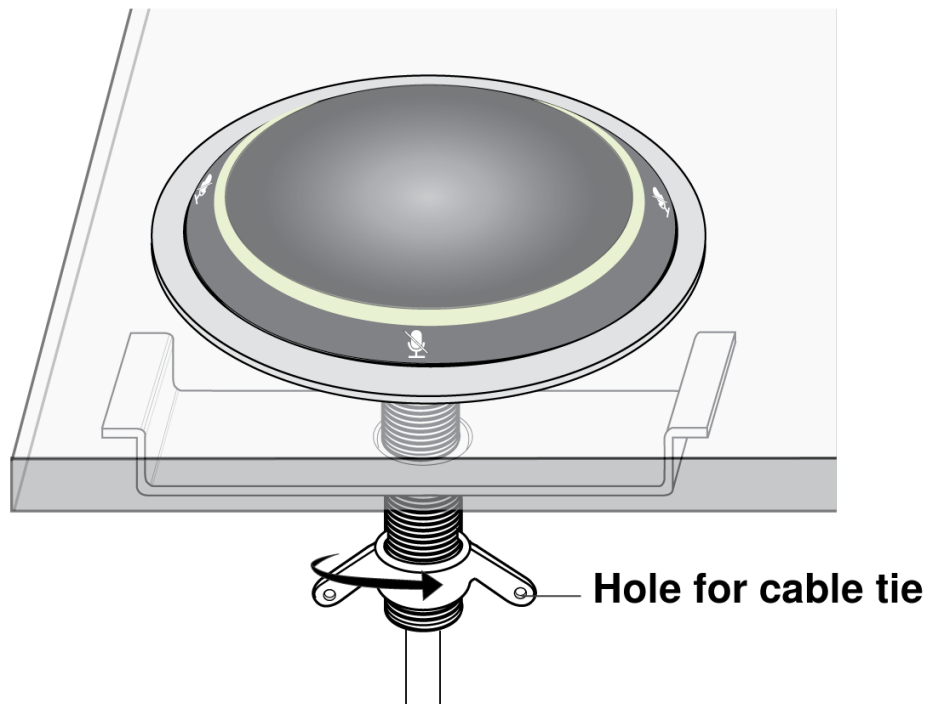

Dimensions

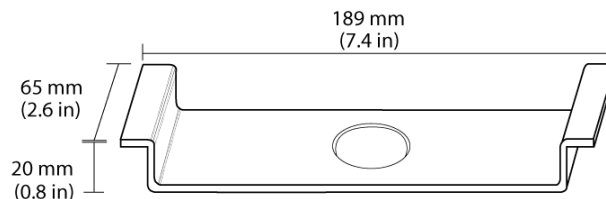
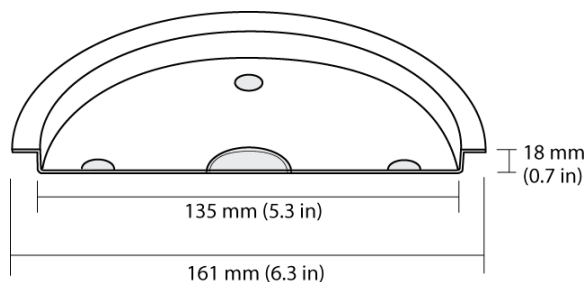

Certifications

CE Notice:

Hereby, Shure Incorporated declares that this product with CE Marking has been determined to be in compliance with European Union requirements. The full text of the EU declaration of conformity is available at the following site: <https://www.shure.com/en-EU/support/declarations-of-conformity>.

Authorized European Importer / Representative:

Shure Europe GmbH
 Department: Global Compliance
 Jakob-Dieffenbacher-Str. 12
 75031 Eppingen, Germany
 Phone: +49-7262-92 49 0
 Fax: +49-7262-92 49 11 4
 Email: EMEAsupport@shure.de

UKCA Notice:

Hereby, Shure Incorporated declares that this product with UKCA Marking has been determined to be in compliance with UK-CA requirements. The full text of the UK declaration of conformity is available at the following site: <https://www.shure.com/en-GB/support/declarations-of-conformity>.

Shure UK Limited - UK Importer

Unit 2, The IO Centre, Lea Road,
 Waltham Abbey, Essex, EN9 1 AS, UK