

---

# WSG-Y16

## User Guide



# Compliance Information

FCC INFORMATION (U.S.A.)

## IMPORTANT NOTICE: DO NOT MODIFY THIS UNIT!

This product, when installed as indicated in the instructions contained in this manual, meets FCC requirements. Modifications not expressly approved by Yamaha may void your authority, granted by the FCC, to use the product.

### Important:

When connecting this product to accessories and/ or another product use only high-quality shielded cables. Cable/s supplied with this product **MUST** be used.

Follow all installation instructions. Failure to follow instructions could void your FCC authorization to use this product in the USA.

### Note:

This product has been tested and found to comply with the requirements listed in FCC Regulations, Part 15 for Class “B” digital devices. Compliance with these requirements provides a reasonable level of assurance that your use of this product in a residential environment will not result in harmful interference with other electronic devices. This equipment generates/uses radio frequencies and, if not installed and used according to the instructions found in the user manual, may cause interference harmful to the operation of other electronic devices. Compliance with FCC regulations does not guarantee that interference will not occur in all installations. If this product is found to be the source of interference, which can be determined by turning the unit “OFF” and “ON”, please try to eliminate the problem by using one of the following measures: This device complies with Part 15 of the FCC Rules.

Operation is subject to the following two conditions:

- a. This device may not cause harmful interference.
- b. This device must accept any interference received including interference that may cause undesired operation.

See user manual instructions if interference to radio reception is suspected.



## COMPANY INFORMATION

- Company: Waves Inc.
- Address: 2800 Merchants Drive, Knoxville TN 37912
- Telephone: 1-865-909-9200
- Type of equipment: Waves interface card
- Model Name: WSG-Y16 V3



# Precautions

## PLEASE READ CAREFULLY BEFORE PROCEEDING.

Please keep this manual for future reference.

### WARNING

Before installing the card in an audio device, please visit the WSG-Y16 V3 mini-YGDAI I/O product page on the Waves website to confirm device compatibility.

Always follow the basic precautions listed below to avoid the possibility of serious injury or even death from electrical shock, short-circuiting, damages, fire, or other hazards. These precautions include, but are not limited to, the following:

- the the please check to make sure that the device is compatible with the card and check possible restrictions regarding the maximum number of Yamaha and third-party expansion cards that can be simultaneously installed. Refer to the owner's manual supplied with the audio device and/or the Yamaha Pro Audio website at [www.yamahaproaudio.com](http://www.yamahaproaudio.com).
- Do not install the card in any Yamaha products not specified by Yamaha for use with the card, to avoid possible electrical shock, fire, or equipment damage.
- Do not attempt to disassemble or modify the card. Do not apply excessive force to card connectors or other card components.
- Mishandling of the card may lead to shock, fire hazard, or equipment failure.
- Be sure to disconnect the power cable of the host device before installing the card and connecting/disconnecting the cables (in order to eliminate shock hazard, undesired noise, and avoid equipment damage).
- Turn off all peripheral devices connected to the host device before installation; unplug all related cables.
- Be sure to properly ground the host device to prevent electrical shock and/or malfunction.
- Do not touch the metallic leads (pins) of the circuit board when handling the card.
- Wear heavy gloves during installation to avoid scratching or cutting your hands on sharp edges.
- Avoid touching exposed connectors and metal parts to minimize the possibility of bad connections.
- Drain all static electricity from your clothing and body before handling the card. Touch an exposed metal part of the host device or other grounded object beforehand. Static electricity can damage the card.
- Do not drop the card or subject it to physical shock as this can result in breakage and/or malfunction.



- Do not drop screws or other small parts inside the card. If power is applied while screws or similar metal objects are loose inside the unit, the card may malfunction or be damaged. If you cannot retrieve dropped objects yourself, refer the problem to qualified Yamaha service personnel.
- The illustrations as shown in this Owner's Manual are for instructional purposes only and may be different from the ones on your equipment.
- The company names and product names in this user guide are the trademarks or registered trademarks of their respective companies.



# Contents

Introduction .....	7
Hardware and Connections .....	8
Getting Started .....	13
Connect the Hardware .....	13
One I/O .....	13
Add I/Os .....	14
Download and Install Software .....	15
Configure the System .....	16
Manual Device Configuration .....	17
Device Firmware .....	18
Identify a Device on the SoundGrid Network .....	18
WSG-Y16 V3 Control Panel .....	19
Clock Page .....	20
System Info Page and About Page .....	22
Presets .....	23
Using an I/O Device with a DAW .....	24



# Introduction

WSG-Y16 is a mini-YGDAI interface card that makes it possible to run Waves plugins directly from selected Yamaha mixing consoles. It provides 16 channels of audio processing per card. Depending on the console model, up to four cards can be used simultaneously. The WSG-Y16 V3 also features Clock Sync-over-Ethernet for syncing multiple consoles and performing digital splits.

SoundGrid is the Waves high-speed networking protocol for moving audio, clock, and other information between a host system and I/O devices—and between I/O devices themselves. A SoundGrid host configures the network, assigning servers and I/O devices to mix, process, or record, depending on the host. SoundGrid devices link to the SoundGrid network with standard Ethernet cable.

SoundGrid is scalable. Connect one I/O device to a DAW and you have a high-quality sound card. Add more I/Os and your system becomes more flexible and powerful. Depending on the host application, a SoundGrid host can assign up to sixteen I/O devices. Complete SoundGrid systems can be networked together to share devices.

Add a server to a SoundGrid system to offload plugin processing from the host CPU to a SoundGrid DSP server. This dramatically increases processing power and enables greater plugin counts, as well as providing very low system latency.

The following Yamaha consoles and mixers are compatible with the WSG-Y16 (V1 or V2 or V3) mini-YGDAI card:

Console Model	Maximum WSG-Y16 I/O cards
PM5D / PM10 / DM2000 / O2R96 / DME64N	x 4
M7CL / CL Series	x 3
DM1000 / LS9-32 / QL Series	x 2
LS9 / O1V96 / DME24N / TXn series	x 1



# Hardware and Connections



## Ethernet Port

Use this port to connect to the SoundGrid network host. When more than one connection is necessary (e.g., additional I/Os or a server), all Ethernet connections must be made through a SoundGrid compatible 1GB switch.

## MIDI Port

Use this port to connect a MIDI cable to control SuperRack SoundGrid from the console. Connect the console's MIDI Out port to the WSG-Y16 MIDI In port.

For MIDI mapping information, please refer to the SuperRack SoundGrid manual. If you have more than one WSG-Y16 card, connect the MIDI cable to one of the cards and select the appropriate port in the SuperRack SoundGrid preferences.

## INSTALLING THE WSG-Y16 (V1 OR V2 or V3)

Before installing the card in a host device, please refer to the Yamaha Pro Audio website for the latest information on the compatible host devices in which the card can be installed: [www.yamahaproaudio.com](http://www.yamahaproaudio.com).

The WSG-Y16 card is installed into one of the mini-YGDAI slots on the rear panel of the console as follows:

1. Turn your console OFF. For additional safety, disconnect the power cable from the AC socket.
2. In the back of your console, unscrew the protective cover from the mini-YGDAI slot that you will be installing to.
3. Carefully line up the WSG-Y16 card with the slot guide and slide the card in, following the directional grooves.
4. Make sure the card is seated firmly. Screw it in for added protection.

Refer to the console's operation guide for further installation instructions.





## SETTINGS

Dipswitches are used to configure the WSG-Y16 card.

Please refer to the following diagrams to determine the location of the dipswitches.

### WSG-Y16 V1

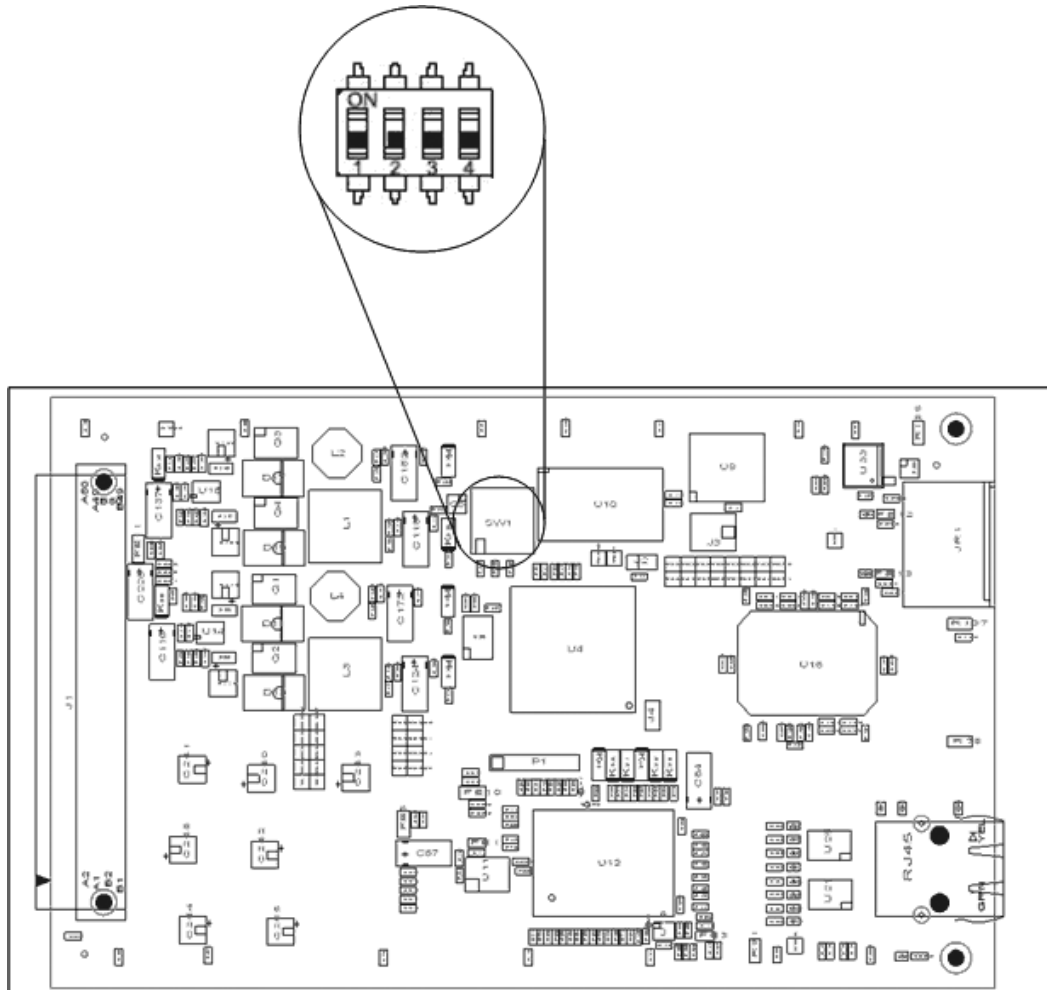

# WSG-Y16 V3

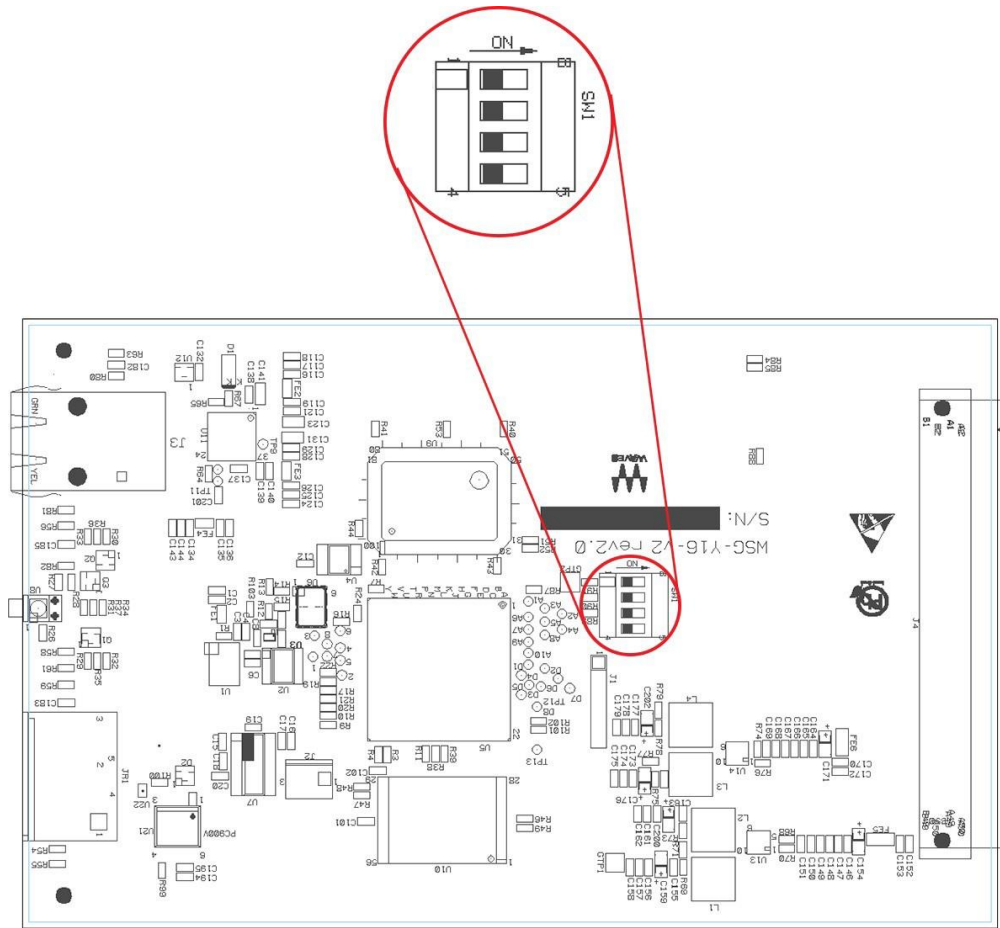

The following example shows how to set up the dipswitches. Slide the dipswitches toward the “ON” marking to turn them on; slide them in the opposite direction to turn them off.

All switches are OFF

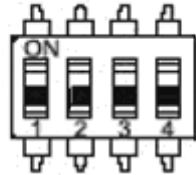

All switches are ON

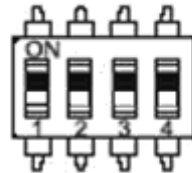

The dipswitches provide the following functionality:

	OFF	ON
<b>DIP 1</b>	Selects 44.1/48 kHz mode (applicable in Emulation mode only)	Selects 88.2/96 kHz mode (applicable in Emulation mode only)
<b>DIP 2</b>	Emulation mode	Native mode
<b>DIP 3</b>	Normal operation of the card	Forces the card into firmware update mode
<b>DIP 4</b>	N/A	N/A

Notes: Native mode can only be used with mixing consoles that support such a mode; please refer to the console manual. When in Native mode, the card will auto-detect the frequency—DIP 1 is ignored. When in doubt, use Emulation mode.



WHEN CHANGING THE SAMPLE RATE IN EMULATION MODE, DO THE FOLLOWING:

1. Make sure that the WSG-Y16 DIP 1 is set to the new sample rate.
2. Make sure the console is set to the new sample rate.
3. On the console, set the channel transfer format as follows:
  - a. 88.2/96 kHz: set to “double speed.”
  - b. 44.1/48 kHz: no specific setting required.
4. Restart the console to activate the changes.



# Getting Started

Configure SoundGrid and assign your devices as follows (however large or small your system):

- A** Connect the hardware
- B** Install the software
- C** Configure your system

## **A** Connect the Hardware

### One I/O

In this example, the single WSG-Y16 Ethernet port is used to connect the console to the SoundGrid host application's SoundGrid ASIO/Core Audio driver for plugin processing and/or DAW playback/recording. The interface is connected directly to the host using a Cat 5e Ethernet cable or better.

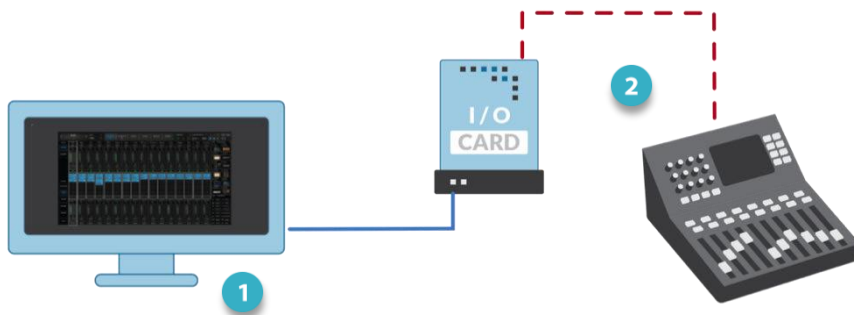

- 1** Host computer with SoundGrid application
- 2** Yamaha console with WSG-Y16 interface card

The host computer's LAN port that's connected to the SoundGrid network should be used for SoundGrid only. Do not share this port with the internet or other networks.

In this configuration, all plugin processing is carried out on the host computer. The speed and power of the host defines overall latency.



## Add I/Os

Adding SoundGrid I/O devices not only increases the number of I/O channels, but lets you have separate devices for stage and FOH, or live room and control room. When you have more than one device in the SoundGrid network, use a "star" network configuration with a 1GB Ethernet switch. Only use switches tested and approved by Waves.

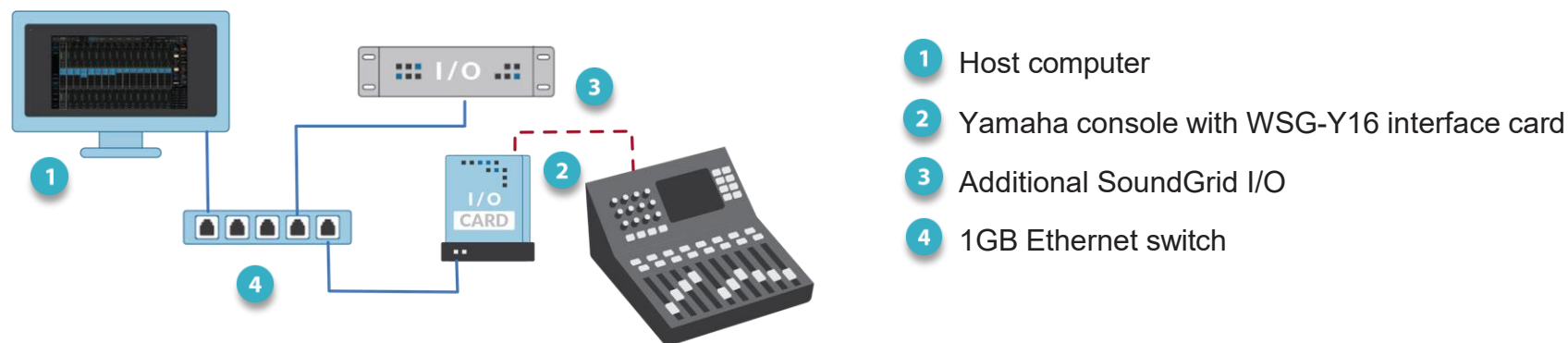

See this [support article](#) for a list of supported switches.

You can connect and assign up to 16 SoundGrid I/O devices to the network, depending on the SoundGrid host application. You can also add more computers to enable streaming between hosts.

## ADD A SERVER

To add a server to your SoundGrid system, just connect it to the Ethernet switch and configure it in your host application. This moves all DSP processing from the host computer to the server, which provides a higher plugin count and enables the eMotion LV1 and ST mixers. Visit the [waves.com hardware pages](http://waves.com/hardware/pages) to learn more about SoundGrid servers.



## B Download and Install Software

### INSTALLING A NEW SOUNDGRID HOST SYSTEM

Installing the Waves SoundGrid host application will also install applicable device drivers and ASIO/Core Audio drivers. Your devices will appear in the Inventory of your host system. If a device is not visible in the Inventory, you may need to install a specific driver from **Waves Central**—please see below. First, however, check the device's connections and power.

### ADDING AN I/O DEVICE TO AN EXISTING SOUNDGRID HOST SYSTEM

If you are already using a Waves SoundGrid host application and your device does not appear in the Network Devices list, use Waves Central to update the host application, which also updates the device drivers—or install just the missing device driver from Waves Central.<sup>1</sup>

#### Waves Central

All Waves software is downloaded and installed via the Waves Central application. To install a specific device driver, launch Waves Central and follow these steps:

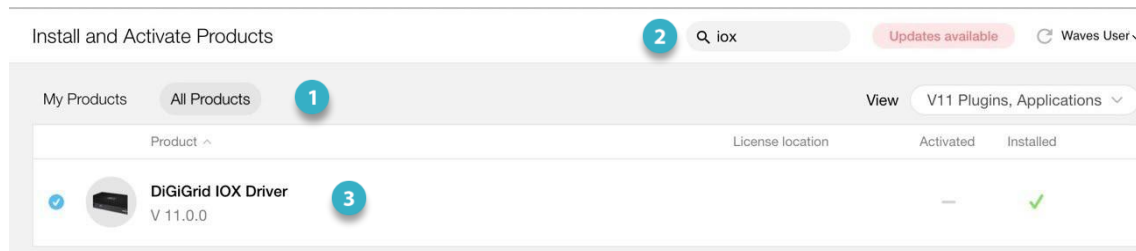

- 1 Choose **All Products**
- 2 Search for the driver by name
- 3 Choose the driver and click **Install**

If you are new to Waves products, begin by downloading the Waves Central installer from the Waves Download Page. See the Waves Central User Guide for instructions on how to install drivers, plugins, and applications.

### LICENSES

You do not need a license to use this device. However, many hosts or specific host configurations do require a license. Refer to your host's [product page](#) for details.

<sup>1</sup> The SoundGrid QRec host is installed with any I/O.



## C Configure the System

A SoundGrid network is configured and devices are assigned in a host's **Setup** window. At the heart of this window are racks where devices are assigned. Any compatible device that's part of the host's SoundGrid network will be available for assignment. This collection of devices is called the **Inventory**. Setup is similar with all hosts: identify the host's LAN port, select a device slot, and use the drop-down menu to choose an available device.

Please consult the user guide of your host application for specific instructions.



SoundGrid QRec





## Manual Device Configuration

All SoundGrid devices are configured in a similar manner. Throughout this section, we configure DiGiGrid IOS on a SoundGrid QRec as an example.

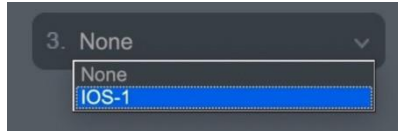

You can assign, remove, and manage a device manually. Click on the **plus** or **arrow** symbol in a device slot to open the **Device Menu**, then select a device.

Any device not already used will be available for assignment. If no other devices are assigned, the current device will become your clock master. Drivers and servers are assigned in the same manner.

See the user guide of your host system for specific instructions on device assignment and I/O channel patching.



## Device Firmware

An I/O that is using outdated or incompatible firmware will not work properly in a SoundGrid network until its firmware is updated. The color of the **FW** button in a device slot indicates the current firmware status.

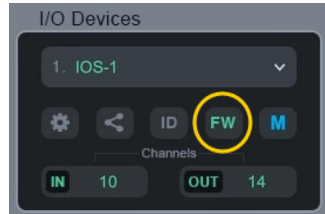

Grey	Compatible firmware
Blue	Compatible firmware, but a newer version exists
Red	Firmware not compatible and must be updated in order to use

If a device requires updated firmware, click on the FW button to start a hardware scan. Do not disconnect the device or turn off the computer before **Done** appears. Once the update is ready, turn the device off and on to reset.

## Identify a Device on the SoundGrid Network



Click on the **ID** button to activate a hard-to-miss LED on the panel of the corresponding hardware device. You can also activate the LED from the top bar of the device's control panel.



# WSG-Y16 V3 Control Panel

WSG-Y16 V3 has a control panel. WSG-16 V1 does not. There are two ways to open the control panel:

## FROM THE DEVICE RACK

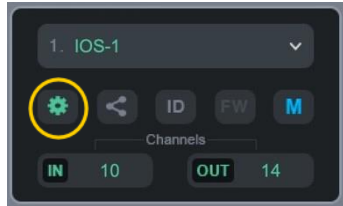

Click the **Gear** button on a device in the rack slot.

## FROM THE DRIVER CONTROL PANEL

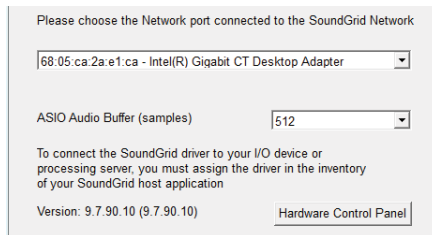

You can also access the control panels of all assigned I/O devices from Driver Control Panel application, which is located here:

PC: C:\Program Files (x86)\Waves\SoundGrid\Driver Control Panel

Mac: System HD/Applications/Waves/SoundGrid

## CONTROL PANEL PAGES



The **About** and **System Info** pages provide information about the unit, such as MAC address, SOE master MAC Address, firmware version, and more. The **Clock** page is used to set up and manage the WSG-HY128.



## Clock Page

Use the Clock page to set the clock source and sample rate for the device and to assess clock status.

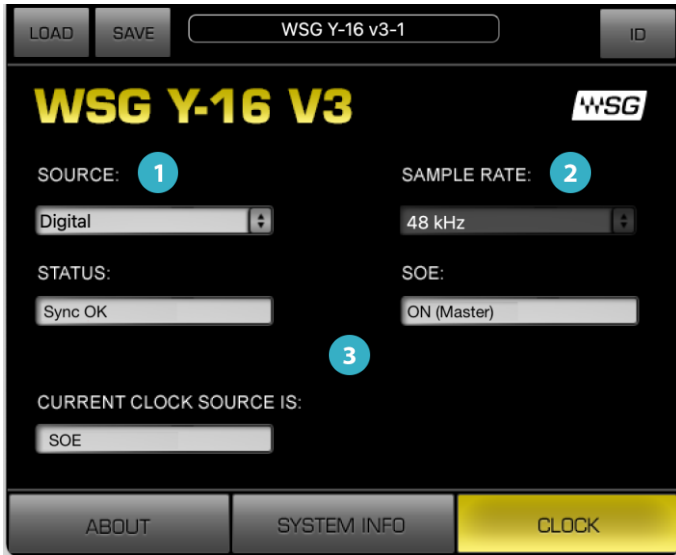

**1 SOURCE** sets the requested clock source.

Internal	The device itself provides the SEO clock.
External WC	Clock is provided by an external device via the Word Clock Input connector.
Sync over Ethernet	The device receives clock from the SoundGrid network.

**2 SAMPLE RATE** sets the sample rate when Clock Source is set to Internal. Range: 44.1 / 48 / 88.2 / 96 kHz.

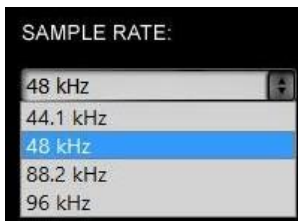

If the device is the network (SOE) clock master, as determined in the Device Racks of the SoundGrid host, then this setting determines the sample rate of the SoundGrid network.

If Clock Source is set to an external clock source, you cannot change the sample rate from the host. The Sample Rate menu is grayed out and inoperative.



### 3 CLOCK STATUS INDICATORS

Three windows on the right side of the Clock control panel help you to quickly assess the network status of the device.

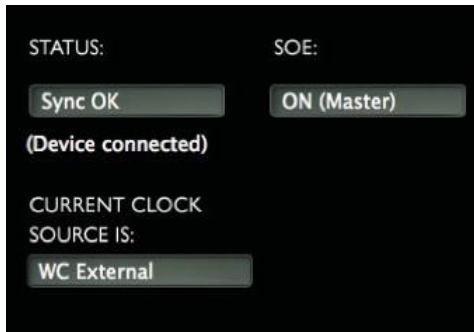

Status	Reports the presence or absence of sync between the WSG-Y16 and the SoundGrid network.
Current Clock Status	Displays the current sync method. This may differ from the choice made in the Source menu.
SOE	Indicates whether this HY128 card is the master or a slave in the SoundGrid network.

When the device is a slave in the SoundGrid network, you will likely sync it to the SoundGrid network clock (via SOE).

Even when the device is an SOE slave, you can lock it to an external clock source. For example, if another SoundGrid I/O device is the SOE master and is locked to a word clock device, you may choose to receive clock from the same external device over word clock from the master device rather than via network SOE.

If the device is clocked to external source and that clock source fails, the device will seek an alternate source of clock, in this priority: digital then SOE. If this fails, the device will fall back to Internal.



## System Info Page and About Page

The **About** page contains a description of the device. The **System Info** page contains technical details about the device, including MAC address, Firmware version, and Module version. This information is useful for troubleshooting. Please have this information handy if you contact Waves technical support concerning the device.



## Presets



The Top Bar is used to load and save device presets and to identify device hardware.

A saved preset includes all Clock and Control panels parameters. Save WSG-HY128 presets to use on future sessions or copy them to another computer to duplicate a configuration.

Click the **ID** button to indicate which WSG-HY128 hardware device belongs to this Control Panel. Clicking the button causes the Network LED on the panel of the WSG-HY128 to flash in a rather psychedelic manner.



# Using an I/O Device with a DAW

Setting up SoundGrid devices with a DAW involves these steps:

## PATCH THE I/O DEVICE AND THE SOUNDGRID ASIO/CORE AUDIO DRIVER

When using a DAW on a SoundGrid network, the SoundGrid ASIO/Core Audio driver serves as a bridge between the I/O device and the DAW. It enables the I/O to communicate with the DAW, and it provides patches. Patching an I/O to the SoundGrid ASIO/Core Audio driver differs slightly among hosts. In some hosts, the When you use a host's Auto-Config tool, the host input channels are patched automatically, in an order based on rack. The order of the devices in the Device Rack determines the default patching order. Please refer to your SoundGrid host's user guide for details.

## CONFIGURE THE DAW FOR SOUNDGRID

1. Set the DAW playback engine to "Waves SoundGrid." The SoundGrid driver channels will now appear in the DAW I/O preferences and in the Input/Output selector in each DAW channel.
2. Route the DAW inputs and outputs to SoundGrid.

