

SONY



UWP-D Series

UWP-D21, UWP-D22, UWP-D26, UWP-D27

UHF Wireless Microphone Packages

Reliable. Affordable. Professional.

As high-resolution content, including 4K, becomes more prevalent in the video production industry, demand increases for high-quality audio solutions to match this content and deliver a fully immersive viewing experience. Today's content professionals are faced with the challenge of capturing high-quality audio quickly and cost-efficiently. The next generation UWP-D Series delivers uncompromising performance in today's fast-paced world of content delivery. With 24-bit digital signal processing (DSP) and true double tuner diversity reception, these receivers and transmitters offer high-quality sound you can rely on, as well as professional features, including tools that help reduce setup time and simplify operation. Whether you're recording news, field production, sports, documentaries, faith, weddings or corporate video, the UWP-D Series helps you do it faster, easier and more reliably.

Superb Sound

Audio transients like percussion hits or tee shots are notoriously difficult for wireless mic companders to reproduce. Sony's 24-bit digital compander retains superb sound quality. In addition, Sony's Multi Interface Shoe™ (MI shoe) with digital audio interface enables you to skip the degradation of D/A (digital-to-analog) and A/D (analog-to-digital) conversion from the receiver to the camera, resulting in higher sound quality with low noise. (Requires SMAD-P5 adaptor, sold separately, and select XDCAM® camcorders. Please see our website for compatible cameras.)

Easier Operating

Match transmitter and receiver frequencies at the touch of a button with NFC SYNC, which takes advantage of nearfield communication.

Lightweight and Compact

Reduced size and weight are ideal for use with small camcorders and interchangeable-lens digital cameras.



UWP-D21
Wireless Microphone
Package



UWP-D22
Wireless Microphone
Package



UWP-D26
Wireless Microphone
Package



UWP-D27
Wireless Microphone
Package



SMAD-P5
MI Shoe Adaptor with
Analog/Digital Audio I/F



URX-P41D
2-channel
Portable Receiver



URX-S03D
2-channel Slot-in
Portable Receiver

24-bit Digital Signal Processing (DSP)

To maximize sound quality across analog wireless transmission, many wireless mic systems use analog compression on the transmission side with corresponding expansion on the receiving side. This is "companding." Unfortunately, analog compressors take the edge off rapid transients, such as percussion hits, bell rings or tee shots. The loss is easy to hear. What should be a sharp ping becomes a dull thud. Unlike others, Sony performs companding with powerful, 24-bit digital signal processing, so you hear transients with full force. You also get far more precise matching between transmitter and receiver time constants, for uncommonly accurate frequency response.

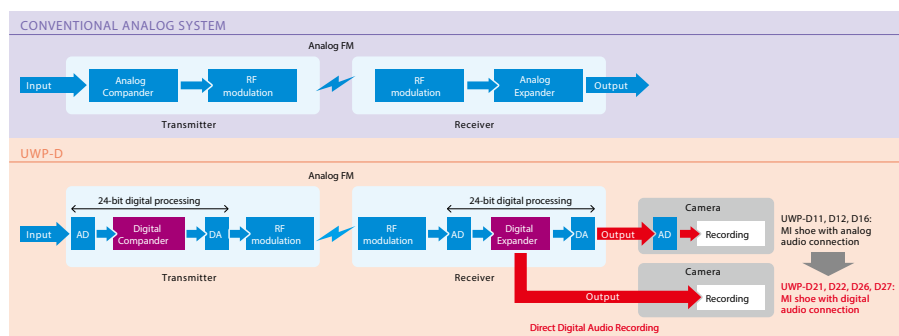

In addition, the URX-P41D enables you to reduce accumulated noise and distortion by skipping digital-to-analog conversion in the receiver and subsequent analog-to-digital conversion in the camera. The secret is support for the Multi Interface Shoe™ (MI shoe) with selectable digital audio interface, which works in conjunction with the SMAD-P5 MI shoe adaptor, sold separately, and select XD-CAM® camcorders. (Please see our website for compatible cameras).

Dynamic Response

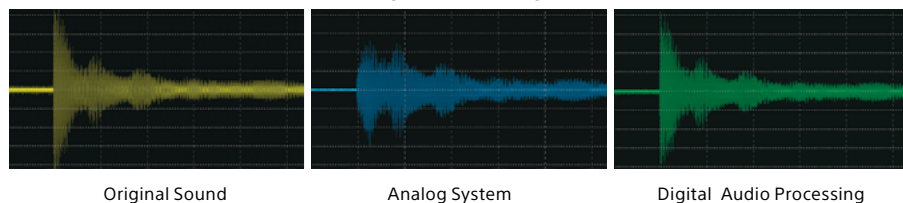

True Diversity Reception for Stable Transmission

At UHF frequencies, moving the receiver antenna even one inch can make the difference between clear reception and RF signal dropouts that can interrupt your audio. Sony protects your signal with true diversity reception: two receiving antennas and two RF tuning circuits. The receiver constantly compares the two signals – and automatically outputs the stronger signal. You can even optimize receiver antenna angles for further transmission clarity. (Note: The URX-P41D provides True Diversity in 1-channel operation, Dynamic Switching Diversity in 2-channel operation.)

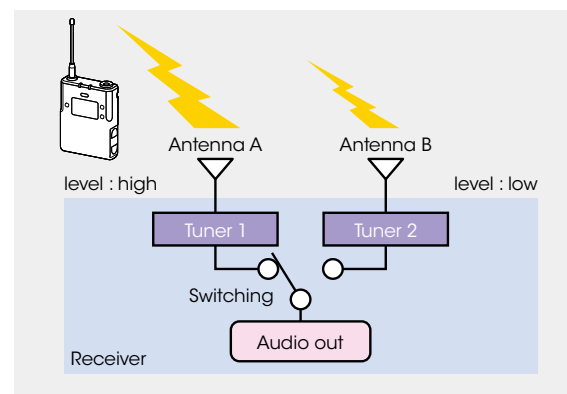

Tuner 1 Tuner 2

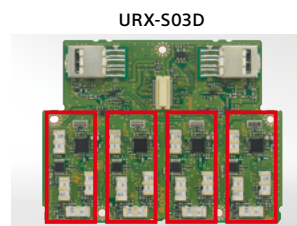

Tuner 1 Tuner 2 Tuner 3 Tuner 4
for Channel 1 for Channel 1

Wide Frequency Coverage

The UWP-D Series transmits at up to 72 MHz* for greater mobility and a wider choice of channels.

*Depending on the country or frequency version.

UWP-D Series

UTX-B40 UTX-P40 UTX-M40 URX-P40 URX-P41D

Simple Channel Setting with NFC SYNC



As one-person crews become common, you don't want to waste time on wireless mic channel selection. That's why Sony created NFC SYNC. Simply hold the button down on the receiver to scan and select the clearest channel. Then touch the transmitter to the receiver to sync the two via near-field communication (NFC). It's that easy.

UTX-B40 UTX-P40 UTX-M40 URX-P40 URX-P41D

Reduced Size and Weight

Reduced size and weight offer added mobility and versatile operation. So you can avoid heavy receivers weighing down your camera operator or bulky transmitters getting in the way of your talent. The UTX-B40 bodypack transmitter and UTX-P40 plug-on transmitter are both 20% smaller than previous models. And the combined URX-P40 receiver/SMAD-P5 adaptor is much shorter than the prior generation – making for a better fit with compact camcorders and digital interchangeable lens cameras.

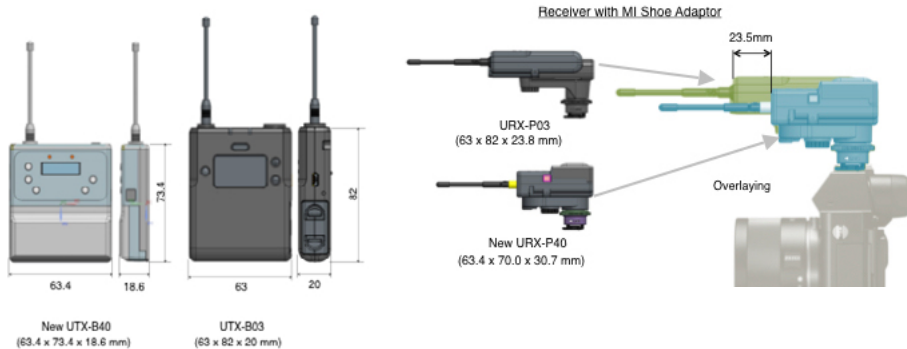

UTX-B40 UTX-P40 UTX-M40 URX-P40

Auto Gain Mode

You often won't know the volume of your talent's voice in advance. Auto Gain mode has you covered. It sets the gain moderately high, then uses a limiter to help prevent distortion.

UTX-B40 UTX-P40 UTX-M40 URX-P40

+15 dB Boost for off-mic Audio

Avoid insufficient audio levels during interviews. The +15 dB boost resets the gain when the microphone is not near the person's mouth.

UTX-B40 UTX-P40 UTX-M40 URX-P40

Line Input

Set the appropriate input levels with MIC/LINE switching levels and adjustable attenuators.

UTX-B40 UTX-P40 UTX-M40 URX-P40 URX-P41D

Channel Memory

When you're using one receiver in combination with two transmitters (4 transmitters when used with the URX-P41D), the Channel Memory function excels. You can instantly switch between the previously set channel and the current channel.



UTX-B40 UTX-P40 UTX-M40 URX-P40 URX-P41D

Transmitter Frequency Sent to Receiver

It's also easy to set up multiple receivers in combination with one transmitter. NFC communication relays transmitter settings such as frequency and compander mode directly to the receiver.

UTX-B40 UTX-P40 UTX-M40 URX-P40 URX-P41D

Headphone Monitor Output

Sound can be monitored directly from the receiver. So even if your camera doesn't have a headphone output, the wireless receiver does.

UTX-B40 UTX-P40 UTX-M40 URX-P40 URX-P41D

Headphone Volume

You can adjust headphone volume with the + or - buttons when you enable the Monitor Mode. Recording level remains unchanged.

UTX-B40 UTX-P40 UTX-M40 URX-P40

Variable Mute

Pressing the MUTE button silences the audio output from the Transmitter. The Variable Mute function lets you determine whether the audio is muted for different operating states.

UTX-B40 UTX-P40 UTX-M40 URX-P40 URX-P41D

Output Level Control

Because some cameras don't offer manual input level control, you can adjust the receiver output level by ±12 dB.

UTX-B40 UTX-P40 UTX-M40 URX-P40 URX-P41D

High-Visibility OLED Display

You'll see operating status instantly and accurately, regardless of whether the unit is being used indoors or outdoors, with the quick response of the OLED (organic light-emitting diode) display.

UTX-B40 UTX-P40 UTX-M40 URX-P40 URX-P41D

USB Power

For long-term use or low-battery emergencies, the receivers and transmitters can draw DC power from the USB interface (excludes the UTX-M40).

SMAD-P5 MI Shoe Adaptor for Simple Connection, Easy Operation



Many of Sony's camcorders and interchangeable lens still cameras incorporate the powerful MI (multi-interface) shoe. The UWP-D Series receivers simplify connections and operation, attaching to the MI shoe with the SMAD-P5 adaptor, sold separately. Using the SMAD-P5, audio signals are transmitted from the wireless receiver to the camera and the receiver gets DC power from the camera – all without plugging in cables. The camera can even control receiver power ON/OFF, for seamless operation. (For a list of compatible cameras, please visit our website.)

In addition, the combination of the URX-P40 and URX-P41D (dual ch. capable) receivers and SMAD-P5 support the digital audio interface. This bypasses the receiver's digital-to-analog converter and the camera's analog-to-digital converters, for lower noise and distortion. The cameras can even show audio information in the viewfinder for enhanced usability in the field. The SMAD-P5 can be switched to analog output for MI connection to Sony cameras without digital MI shoe capability.

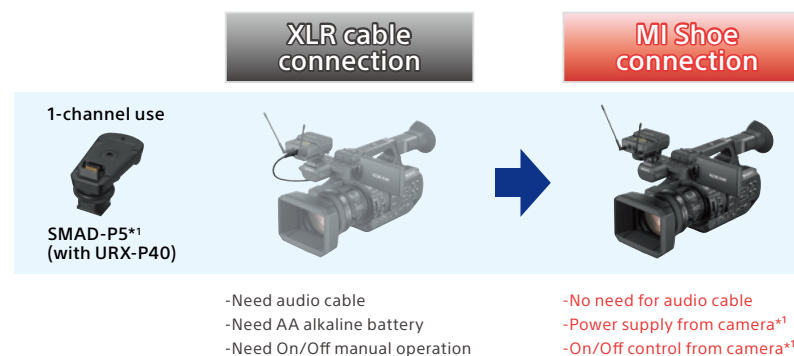

*1 The SMAD-P5 cannot be used with the URX-P03 nor the URX-P03D.

UWP-D Series

UTX-B40 UTX-P40 UTX-M40 URX-P40

Interchangeable Mic Capsule

In addition to the supplied high-quality dynamic cardioid capsule, the handheld mic can accept any of Sony's DWX Series capsules, including the CUC31, F31 or F32. The threading is 1.25"/28 pitch (31.3 mm/pitch 1.0 mm), allowing use of many industry standard thread third party microphone capsules



UTX-B40 UTX-P40 UTX-M40 URX-P40

+48V Power Supply

The UTX-P40 plug-on transmitter accommodates dynamic and condenser microphones that need DC 48 V power.

Compatible with UWP Series / WL-800 Series

The digital compander can recognize and match the operations of Sony's UWP and WL-800 Series allowing you to use the UWP-D transmitter with a UWP or WL-800 receiver. You can also use a UWP or WL-800 transmitter with a UWP-D receiver. In addition, the Infrared Port enables the UTX-B40, UTX-M40 and UTX-P40 transmitters to accept channel setting, compander mode and AUTO SET status from the URX-P03, URX-P03D and URX-S03D receivers.



URX-S03D Slot-in Receiver For Shoulder Camcorders with XDCAM® Camcorders

- 2-channel digital connection directly from the DSP digital output of the URX-S03D via a D-sub 15-pin interface
- Camcorder can show each wireless microphone's RF/AF level in the viewfinder
- Camcorder corrects for audio delay (0.725 msec) for perfect lip sync

with HDCAM® Camcorders

- Single-channel analog connection from the URX-S03D via a D-sub 15-pin interface
- Two audio signals from two transmitters can be mixed and output as a single channel
- Camcorder can show each wireless microphone's RF/AF level in the viewfinder



High Quality Audio

For even higher fidelity, the URX-S03D incorporates a sophisticated amplifier featuring an oversized electrolytic capacitor to deliver ample power.

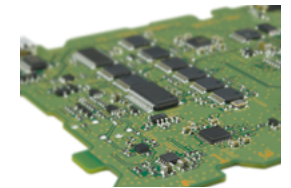

URX-P41D External Mic Input and 3-Channel Mixer

To support a broader range of field audio requirements, the URX-P41D provides a Mono/Stereo Mic input for plug-in power external mics and Sony BMP-type lavalier mics. You can individually assign the audio signal inputs from Tuner 1, Tuner 2, and the external microphone to OUTPUT 1 (L channel), OUTPUT 2 (R channel), or Both via menu settings. So you can freely mix audio signals for stereo or mono output.



BMP (Mono)
T/R/S: Hot/+5V/Ground



Plug-in Power (Mono/Stereo)
T/R/S: L +2.5V/ R +2.5V/ Ground

Example 1: Using Lavalier Microphone

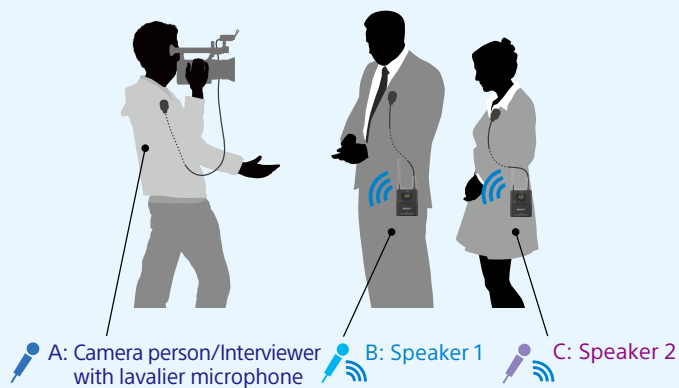
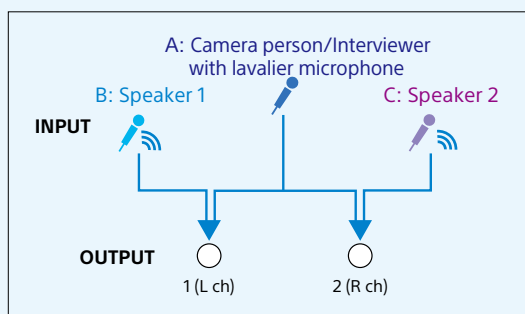



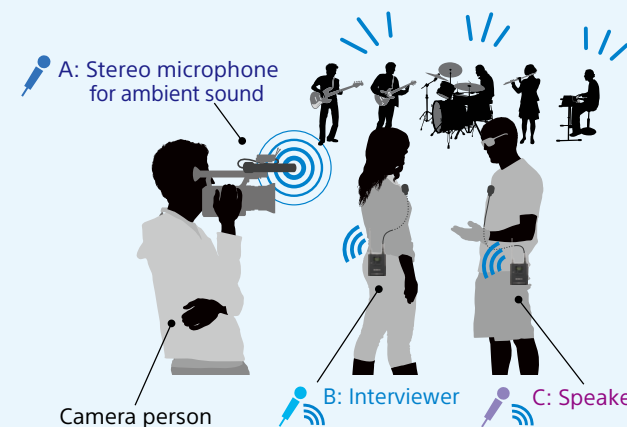
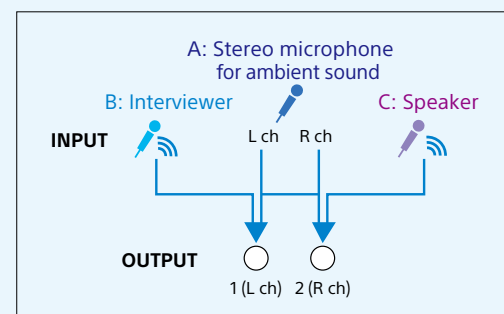































Example 2: Using Stereo Microphone



UWP-D Series

Package Lineup

	Frequencies are as follows:								
UWP-D21 	 UTX-B40 : Bodypack Transmitter	 URX-P40 : Portable Receiver	 Omni-directional Lavalier Microphone	 Microphone Holder Clip	 XLR-BMP Cable	 Stereo Mini-BMP Cable			
UWP-D22 	 UTX-M40 : Handheld Wireless Microphone	 URX-P40 : Portable Receiver	 Microphone Holder	 XLR-BMP Cable	 Stereo Mini-BMP Cable	 Belt Clip			
UWP-D26 	 UTX-P40 : Plug-on Transmitter	 UTX-B40 : Bodypack Transmitter	 URX-P40 : Portable Receiver	 Omni-directional Lavalier Microphone	 Microphone Holder Clip	 XLR-BMP Cable	 Stereo Mini-BMP Cable	 Soft Case	
UWP-D27 	 (1) URX-P41D : 2ch Receiver	 (2) UTX-B40 : Bodypack Transmitters	 Omni-directional Lavalier Microphone x 2	 Microphone Holder Clip x 2	 XLR-BMP Cable x 2	 Stereo Mini-BMP Cable x 2			

Frequencies

	Operating frequencies	470 MHz to 542 MHz	536 MHz to 608 MHz	566 MHz to 630 MHz	638 MHz to 694 MHz	638 MHz to 698 MHz	710 MHz to 782 MHz	794 MHz to 806 MHz	806 MHz to 810 MHz	925 MHz to 937 MHz	941 MHz to 960 MHz
UC/LA	version Selectable frequencies	14/UC 2772 (in 25-kHz steps)	25/UC 2772 (in 25-kHz steps)			42/LA 2310 (in 25-kHz steps)					90/U 654 (in 25-kHz steps)
CE	version Selectable frequencies	21/CE 2880 (in 25-kHz steps)		33/CE 2560 (in 25-kHz steps)	42/CE 2240 (in 25-kHz steps)						
CN	version Selectable frequencies					29/CN 2880 (in 25-kHz steps)					
E	version Selectable frequencies							E 94 (in 125-kHz steps)			
J	version Selectable frequencies								JB 94 (in 125-kHz steps)		
KR	version Selectable frequencies									KR3 94 (in 125-kHz steps)	

*1 566 MHz to 608 MHz and 614 MHz to 638 MHz

Products



UTX-B40 Bodypack Transmitter

- High quality sound with Sony Digital Audio Processing
- NFC SYNC function for quick and easy secure channel setting (IR sync capability with URX-P03, URX-P03D, and URX-S03D receivers)
- Auto and manual gain mode
- +15 dB gain volume boost mode for off-mic audio
- Switchable MIC/LINE input level
- Transmitter frequency sent to receiver for matching multiple receivers to one transmitter
- Variable muting function
- Compatibility with Sony WL-800/UWP/UWP-D series
- High visibility OLED display, ideal for indoor/outdoor use
- USB connector for power supply
- Includes ECM-V1BMP lavalier microphone



UTX-M40 Handheld Wireless Microphone

- High quality sound with Sony Digital Audio Processing
- NFC SYNC function for quick and easy secure channel setting (IR sync capability with URX-P03, URX-P03D, and URX-S03D receivers)
- Interchangeable head for wide choice of microphone capsules
- Auto gain mode volume control
- +15 dB gain volume boost mode for off-mic audio
- Transmitter frequency sent to receiver for matching multiple receivers to one transmitter
- Variable muting function
- Compatibility with Sony WL-800/UWP/UWP-D series
- High visibility OLED display (indoor/outdoor use)



UTX-P40 Plug-on Transmitter

- High quality sound with Sony Digital Audio Processing
- NFC SYNC function for quick and easy secure channel setting (IR sync capability with URX-P03, URX-P03D, and URX-S03D receivers)
- Auto and manual gain mode
- +15 dB gain volume boost mode for off-mic audio
- Switchable MIC/LINE input level
- +48V power supply
- Transmitter frequency sent to receiver for matching multiple receivers to one transmitter
- Variable muting function
- Compatibility with Sony WL-800/UWP/UWP-D series
- High visibility OLED display, ideal for indoor/outdoor use
- USB connector for power supply



URX-P41D 2-channel Portable Receiver

- High quality sound with Sony Digital Audio Processing
- External microphone input for additional wired microphone
- 3-channel mixing function included
- NFC SYNC function for quick and easy secure channel setting
- True Diversity Reception System*2 for stable reception
- Channel memory function for fast switching between four receiver frequencies
- Headphone output for monitoring
- Monitor mode for using a receiver as an ear monitor
- Compatible with Sony's WL-800/UWP series
- Output level control for receiver
- High visibility OLED display (indoor/outdoor use)
- USB connector for power supply
- Digital/analog switchable audio interface support using SMAD-P5 Multi-Interface Shoe Adapter (option)*1

*1 For details on cameras that support this function, visit the Sony website
 *2 True Diversity for 1-channel use / Dynamic Switching Diversity for 2-channel use



URX-P40 Portable Receiver

- High quality sound with Sony Digital Audio Processing
- NFC SYNC function for quick and easy secure channel setting
- True double tuner diversity for stable signal reception
- Channel memory function for fast switching between two receiver frequencies
- Headphone output for monitoring
- Monitor mode for using a receiver as an ear monitor
- Compatible with Sony's WL-800/UWP series
- Output level control for receiver
- High visibility OLED display (indoor/outdoor use)
- USB connector for power supply
- Digital/analog switchable audio interface support using SMAD-P5 Multi-Interface Shoe Adaptor (option)*1

*1 For details on cameras that support this function, visit the Sony's website

Supplied Output Cable



XLR-BMP Cable (1)

Stereo Mini-BMP Cable (1)

Supplied Output Cable



XLR-BMP Cable (2)

Stereo Mini-Dual BMP Cable (1)



URX-S03D 2-channel Slot-in Portable Wireless Receiver

- Sony's Digital Audio Processing
- High quality audio amplifier adopted
- Wireless receiver for Sony shouldercams and accessory buckets
- Direct digital connection to XDCAM, DWA-01D or DWA-F01D
- Easy-to-use Automatic Channel Setting mode
- True Diversity Reception System for stable reception
- Compatibility with Sony WL-800/UWP/UWP-D series
- Robust metal body
- Weatherproof structure
- Selectable squelch

UWP-D Series

How to Attach to Camera (Options)

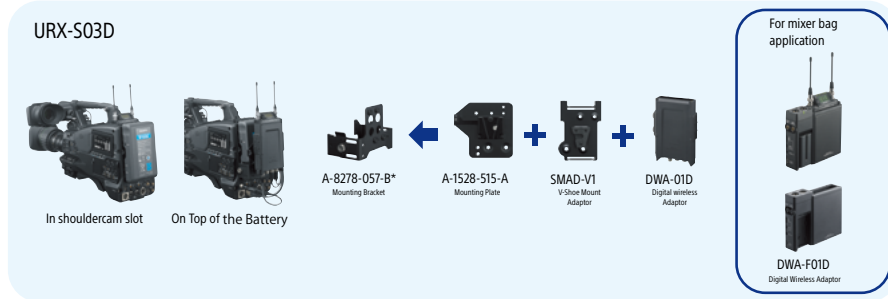

Accessories: UWP-D Series

<p>SMAD-P2 Shoe Mount Adaptor for URX-P03/URX-P03D</p>	<p>SMAD-P3 Multi Interface Shoe (MI Shoe) adaptor for URX-P03</p>	<p>SMAD-P3D Multi Interface Shoe (MI Shoe) adaptor for URX-P03D (Dual Channel)</p>	<p>SMAD-P4 Shoe Mount Adaptor for URX-P40</p>	<p>SMAD-P5 Multi Interface Shoe (MI Shoe) adaptor for URX-P40D and URX-P41D</p>
<p>ECM-V1BMP Omni-directional Lavalier Microphone</p>	<p>ECM-X7BMP Uni-directional, Lavalier Microphone</p>	<p>ECM-77BMP Omni-directional Lavalier Microphone</p>	<p>ECM-44BMP Omni-directional Lavalier Microphone</p>	<p>ECM-77BC Omni-directional Lavalier Microphone</p>
<p>ECM-44BC Omni-directional Lavalier Microphone</p>	<p>ECM-322BMP Omni-directional Headset Microphone</p>	<p>AD-RV1B2 Windscreen Pack (SPCS)</p>	<p>SAD-HV1B2 Holder Clip Pack (4PCS)</p>	<p>BATC-3AA Battery Case for UTX-B03/UTX-B03HR/UTX-P03/URX-P03/URX-P03D</p>
<p>BATC-4AA Battery Case for UTX-B40/URX-P41D</p>	<p>EC-0.46BX 3-pole Locking Mini Plug-XLR(M) Cable</p>	<p>EC-1.5BX 3-pole Locking Mini Plug-XLR(F) Cable</p>	<p>EC-0.8BM 3-pole Locking Mini Plug-Stereo Mini Plug Cable</p>	<p>EC-1.5CF SMC9-4P Plug-XLR(F) Cable</p>
<p>BLC-BP2 Belt Clip (2PCS)</p>	<p>SAD-M01 Microphone Holder</p>	<p>CU-C31 Capsule Unit • Condenser type • Cardioid • 60 Hz - 20 kHz</p>	<p>CU-F31 Capsule Unit • Dynamic type • Super cardioid • 60 Hz - 18 kHz</p>	<p>CU-F32 Capsule Unit • Dynamic type • Wide cardioid • 70 Hz - 18 kHz</p>

SPECIFICATIONS

UTX-M40

Frequency Response Characteristics

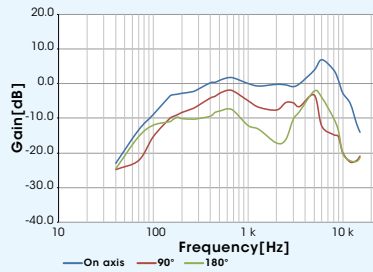

Directivity Characteristics (1 kHz)

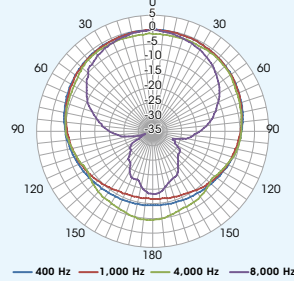

ECM-V1BMP

Frequency Response Characteristics

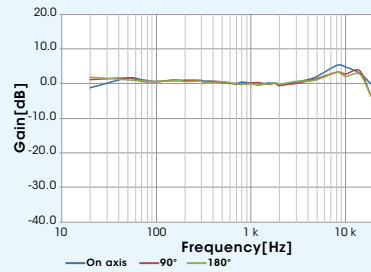

Directivity Characteristics (1 kHz)

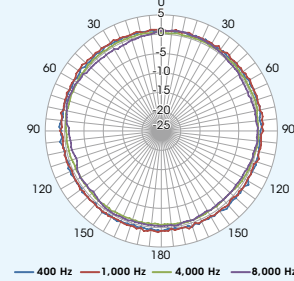

Model Code	ECM-V1BMP
Frequency Response	40 Hz to 20 kHz
Directivity	Omni-directional
Capsule Type	Condenser
Sensitivity	-43.0 dB ±3.0 dB (1 kHz/Pa)
Dynamic Range	86 dB or more
Maximum Input Sound Pressure Level	120 dB SPL
Microphone Head	φ6.8 x 19.5 mm (9/32 X 25/32 inches) (diameter/length)
Mic Cable	1.2 m (3.9 feet)
Power Requirements	DC 5V
Supplied Accessories	Windscreen (1) Horizontal Clip (1)

	UTX-B40 Bodypack Transmitter	UTX-M40 Handheld Transmitter	UTX-P40 Plug-on Transmitter
Oscillator Type	Crystal-controlled PLL synthesizer		
Antenna Type	1/4λ wavelength wire antenna		
Carrier Frequencies	14UC : 470.125 MHz to 541.875 MHz(UHF-TV channels 14 to 25)		
	25UC : 536.125 MHz to 607.875 MHz (UHF-TV channels 25 to 36)		
	42LA : 638.125 MHz to 697.875 MHz(UHF-TV channels 42 to 51)		
	90U : 941.625 MHz to 951.875 MHz, 953.000 MHz to 956.125 MHz, and 956.625 MHz to 959.625 MHz		
	21CE : 470.025 MHz to 542.000 MHz(UHF-TV channels 21 to 29)		
	33CE : 566.025 MHz to 630.000 MHz(UHF-TV channels 33 to 40)		
	42CE : 638.025 MHz to 694.000 MHz (UHF-TV channels 42 to 48)		
	38CN : 710.025 MHz to 782.000 MHz(UHF-TV channels 38 to 46)		
RF Output Power	30 mW/5 mW selectable (UC, U, CE, LA, CN models) 10 mW/2 mW selectable (J, E, KR models)		40 mW/5 mW selectable (UC, U, LA models) 30 mW/5 mW selectable (CE, CN models) 10 mW/2 mW selectable (J, E, KR models)
	Electret condenser	Dynamic	-
	Omni-directional	Uni-directional	-
Input Connector	3.5mm diameter 3-pole locking mini jack		XLR-3-11C type (female)
Reference Audio Input Level	-60 dBV (MIC input, GAIN MODE set to NORMAL, 0 dB attenuation) +4 dBu (LINE input)	-55 dBV (GAIN MODE set to NORMAL, 0 dB attenuation)	-60 dBV (MIC input, GAIN MODE set to NORMAL, 0 dB attenuation)
Maximum Audio Input Level	-	151 dB SPL (21 dB attenuation, using supplied microphone unit)	-
Audio Attenuator Adjustment Range	0 dB to 27 dB (3dB steps)	0 dB to 21 dB (3 dB steps)	0 dB to 48 dB (3 dB steps)
Frequency Response	23 Hz to 18 kHz (Typical) (UC, U, CE, LA, CN, E, KR models)	70 Hz to 18 kHz (Typical) (UC, U, CE, LA, CN, E, KR models)	23 Hz to 18 kHz (Typical) (UC, U, CE, LA, CN, E, KR models)
	40 Hz to 15 kHz (Typical) (J model)	70 Hz to 15 kHz (Typical) (J model)	40 Hz to 15 kHz (Typical) (J model)
Signal-to-Noise Ratio	60 dB (-60 dBV, 1 kHz sine wave input) 102 dB (GAIN MODE set to AUTO GAIN, max deviation, A-weighted) 96 dB (GAIN MODE set to NORMAL, max deviation, A-weighted)		
Distortion	0.9% or less (-60 dBV, 1 kHz input)		
Audio Delay	Approx. 0.35 ms		
Tone signal frequency	In UWP-D compander mode: 32.382 kHz / In UWP compander mode: 32 kHz / In WL800 compander mode: 32.768 kHz		
Display	OLED		
Power Requirements	DC 3.0 V (two LR6/AA size alkaline batteries) DC 5.0 V (supplied from USB Type-C connector)		
Battery Life (measured with two Sony LR6/AA size alkaline batteries at 77 °F (25 °C), DISPLAY MODE set to AUTO OFF)	Approx. eight hours with output power of 30 mW (UC, U, CE, LA, CN models)		During +48V OFF: Approx. seven hours with output power of 40 mW (UC, U, LA models) Approx. eight hours with output power of 30 mW (CE, CN models) Approx. 10 hours with output power of 10 mW (J, E, KR models)
	Approx. 10 hours with output power of 10 mW (J, E, KR models)		During +48V ON and ECM-673 connection: Approx. six hours with output power of 40 mW (UC, U, LA models) Approx. six hours with output power of 30 mW (CE, CN models) Approx. seven hours with output power of 10 mW (J, E, KR models)
Operating Temperature	32°F to 122°F (0 °C to 50 °C)		
Storage/Transport Temperature	-4 °F to +131 °F (-20 °C to +55 °C)		
Dimensions (W x H x D)	2 1/2 x 2 7/8 x 3/4 in. (63 x 73 x 19 mm) (W / H / D) (excluding antenna)	ø1 15/16 x 10 1/4 in. (48 x 258 mm) (diameter / length)	1 1/2 x 3 7/8 x 1 1/2 in. (38 x 98 x 38 mm) (W / H / D) (including the audio input connector)
Weight	Approx. 2.9 oz (83 g) (excluding batteries)	Approx. 9.0 oz (255 g) (excluding batteries)	Approx. 4.9 oz (139 g) (excluding batteries)

SPECIFICATIONS

	URX-P40 Portable Receiver	URX-P41D 2-channel Portable Receiver	URX-S03D Slot-in Portable Receiver
Oscillator Type	Crystal-controlled PLL synthesizer		
Reception Type	True diversity method	Space diversity*	True diversity
Antenna Type	1/4 λ wavelength wire antenna (angle-adjustable)		Detachable
Carrier Frequencies	14UC : 470.125 MHz to 541.875 MHz(UHF-TV channels 14 to 25)		
	25UC : 536.125 MHz to 607.875 MHz (UHF-TV channels 25-36)		
	42LA : 638.125 MHz to 697.875 MHz(UHF-TV channels 42-51)		
	90U : 941.625 MHz to 951.875 MHz, 953.000 MHz to 956.125 MHz, and 956.625 MHz to 959.625 MHz		
	21CE : 470.025 MHz to 542.000 MHz(UHF-TV channels 21-29)		
	33CE : 566.025 MHz to 630.000 MHz(UHF-TV channels 33-40)		
	42CE : 638.025 MHz to 694.000 MHz (UHF-TV channels 42-48)		
	29CN : 638.025 MHz to 694.000 MHz (UHF-TV channels 29-35)		
	E : 794.125 MHz to 805.875 MHz		
	JB : 806.125 MHz to 809.750 MHz		
KR : 925.125 MHz to 937.500 MHz			
Frequency Response	23 Hz to 18 kHz (Typical) (UC, U, CE, LA, CN, E, KR models)		
Signal-to-Noise Ratio	40 Hz to 15 kHz (Typical) (J model)		
	60 dB (1 kHz sine wave, 5 kHz modulation) 96 dB (max deviation, A-weighted)		
Distortion (T.H.D)	0.9% or less (1 kHz sine wave, 5 kHz modulation)		
Audio Delay	Approx. 0.35 ms (analog output) Approx. 0.24 ms (digital output)	Approx. 0.375 ms	
Analog Input	-	3.5 mm diameter 3-pole mini jack, balanced	-
Analog Input Level	-	-50 dBV (±12dB Adjustable, 3-dB step)	-
Audio output connector	3.5mm diameter 3-pole locking mini jack, external connection	3.5 mm diameter 3-pole mini jack, unbalanced, external connection	D-sub 15pin, unbalanced
Analog Output Level**	-60 dBV (3.5 mm diameter 3-polelocking mini jack, analog output, 0 dB audio output level) -20 dBFS (external connection, digital output, 0 dB audio output level) -50 dBFS (external connection, analog output, 0 dB audio output level)	-60 dBV (at ±5 kHz deviation)	-40 dBu (at ±5kHz deviation)
Analog Audio Output Adjustment Range	-12 dB to +12 dB (3-dB step)		-
Headphone output connector	3.5 mm diameter mini jack	ø3.5 mm (5/32 inch) stereo mini jack	-
Headphone Output Level	Max. 10mW (16-ohm)	Max 10 mW (16-ohm)	-
Tone signal frequency	In UWP-D compander mode: 32.382 kHz / In UWP compander mode: 32 kHz / In WL800 compander mode: 32.768 kHz		
Display	OLED	OLED	LCD
Power Requirements	DC 3.0 V (two LR6/AA size alkaline batteries) DC 5.0 V (supplied from USB Type-C connector)	DC 3.0 V (two LR6/AA size alkaline batteries) DC 5.0 V (supplied from Type-C connector)	DC 7.0 V
Battery Life	Approx. six hours with two AA size alkaline (LR6) batteries at 25 °C (77 °F), DISPLAY MODE set to AUTO OFF	Approx. 4.5 hours with two AA size alkaline (LR6) batteries at 25 °C (77 °F), DISPLAY MODE set to AUTO OFF	-
Operating Temperature	32°F to 122°F (0°C to 50°C)		
Storage/ Transport Temperature	-4°F to +131°F (-20°C to +55°C)		
Dimensions (W x H x D)	2 1/2 x 2 7/8 x 1 1/4 in. (63 x 70 x 31 mm) (excluding antenna)	2 1/2 x 2 7/8 x 1 7/16 in. (63 x 70 x 35 mm) (excluding the antennas)	3 1/2 x 4 5/8 x 1 1/4 in. (88 x 116.2 x 31.2 mm) (excluding the antennas)
Weight	Approx. 4.6 oz (131 g) (excluding batteries)	Approx. 5.6 oz (159 g) (excluding batteries)	Approx. 10.7 oz. (303 g) (with supplied antennas attached)

*1 True Diversity for 1-channel use / Dynamic Switching Diversity for 2-channel use.

**2 0dBμV= 1μV EMF, 0dBu=0.775Vrms, 0dBV=1V, 0dB SPL=2x10⁻⁵ Pa.

	SMAD-P5 Multi Interface (MI) Shoe Adaptor
Output impedance	1 kΩ or less
Voice delay	1.16 ms (Digital)
Operating temperature	32 °F to 122 °F (0 °C to 50 °C)
Storage temperature	-4 °F to +131 °F (-20 °C to +55 °C)
Dimensions (W/H/D)	Approx. 1 3/8 in. x 1 7/16 in. x 2 5/8 in. (34 mm x 35 mm x 65 mm)
Weight	Approx. 1.0 oz. (27 g) (excluding terminal cap)
Supplied accessories	Operating Instructions (1) (this document), Warranty card (1)

©2022 Sony Electronics Inc. All rights reserved.

Reproduction in whole or in part without written permission is prohibited.

Features, design, and specifications are subject to change without notice.

Weights and measurements are approximate.

Some images in this brochure are simulated.

Sony and the Sony logo are trademarks of Sony.

All other trademarks are the property of their respective owners.

Please visit Sony's professional website or contact your Sony representative for specific models available in your region.

Sony Imaging Products & Solutions - Americas
115 West Century Road, Suite 250
Paramus, NJ 07652
pro.sony/uwprd

A-1208-B (MK20383V1)

Issued in USA (11/22)