



MX392 MX393

Boundary Microphones

The Shure small, surface-mounted electret condenser microphone series, MX392-393, user guide.
Version: 4 (2019-J)

Table of Contents

MX392 MX393 Boundary Microphones	3	Wiring Diagram	8
General Description	3	Mute Button Configuration	9
Features	3	Connecting to an Automatic Mixer	10
Model Variations	3	Logic Wiring	10
Interchangeable Cartridges	3	Changing SWITCH OUT to Always Momentary	11
Permanent Installation	5	Painting	11
MX392 and MX393	5	Specifications	12
Microphone Placement	6	Furnished Accessories	15
MX392BE	6	Certifications	15
Configuration	8		
DIP Switches	8		

MX392 MX393 Boundary Microphones

General Description

Shure Microflex® MX300 Series microphones are surface-mounted electret condenser microphones designed primarily for mounting on conference tables, stage floors, and lecterns. Their high sensitivity and wide frequency range make them especially suitable for picking up speech and vocals in sound reinforcement and recording applications. Interchangeable cartridges provide the installer with greater flexibility and make it possible to easily reconfigure microphone coverage as the need arises. The MX392 and MX393 models include an internal preamplifier.

MX300 Series microphones take advantage of the principle that, at a barrier or boundary, the sound pressure level doubles. When placed near a sufficiently large boundary surface, the microphone has 6 dB higher sensitivity and approximately 3 dB greater direct-to-reverberant sound ratio.

Features

The MX392, MX392BE, and MX393 feature programmable logic input and output. Additionally they provide following benefits:

- Flat frequency response across the vocal range for uncolored sound
- Interchangeable cartridges that provide a choice of polar pattern for each application
- Sleek, low-profile design for surface mounting
- Programmable mute button
- LED indicator
- Logic input/output for remote control or use with automatic mixers
- RF filtering

Model Variations

The polar pattern of the included cartridge is indicated by a model number suffix:

/C Cardioid

/S Supercardioid

/O Omnidirectional

/N Cartridge not included

Interchangeable Cartridges

Remove Grille

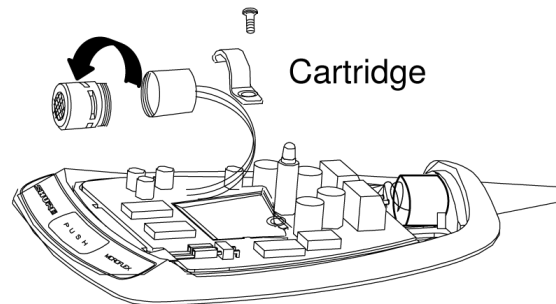
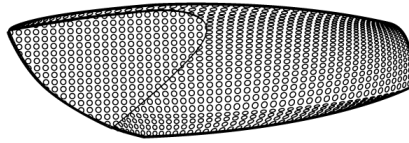

Cartridge

Remove Bracket

Microflex microphones use interchangeable cartridges that allow you to choose the polar pattern for different installations.

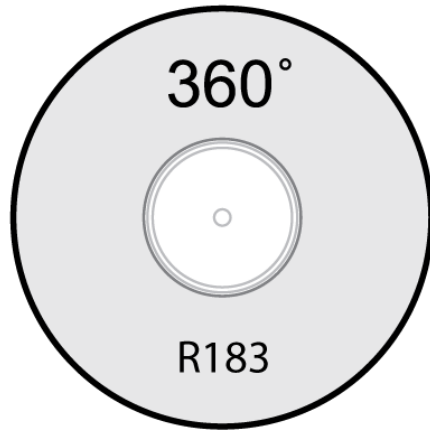

Omnidirectional

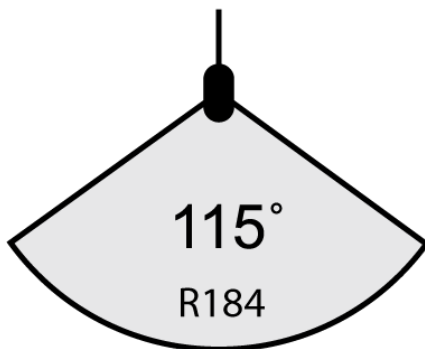

Supercardioid

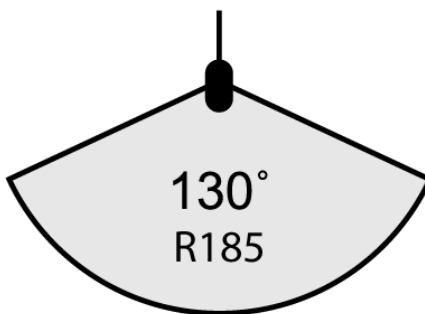

Cardioid

Cartridge Polar Patterns

Permanent Installation

MX392 and MX393

1. Remove grille to access mounting key holes.
2. Cut slots into pads.
3. Slide microphone forward to engage screws in slots.

Note: If using rear side-exit cable option, only drill two outer holes.

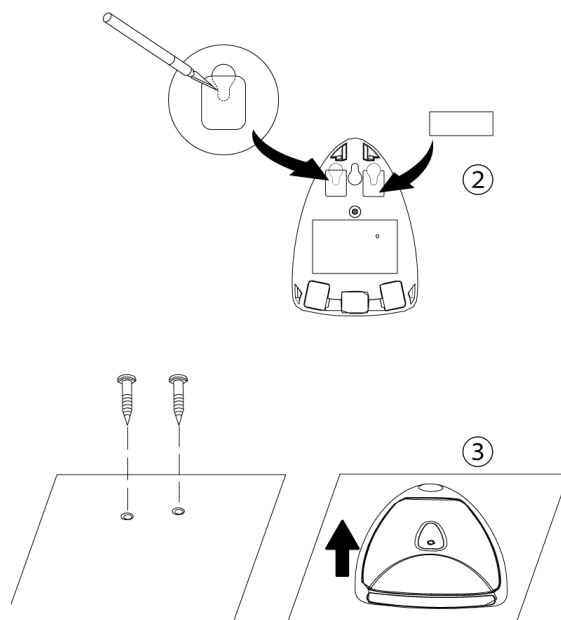

Microphone Placement

For best low-frequency response and rejection of background noise, place the microphone on a large, flat surface, such as a floor, table, or lectern.

To reduce reverberance, avoid reflective surfaces above or to the side of the microphone, such as beveled sides of pulpits or overhanging shelves.

MX392BE

Once placement has been determined, the microphones can be permanently installed. First, drill the hole in the selected area to allow the bottom entry cable to be conveniently routed out of sight. Then use the pressure sensitive adhesive to keep the microphone firmly in place.

Drilling the hole:

1. Determine the cutting area for the bottom exit cable and drill a 1/2" (12.7 mm) circular hole. Remove all debris from the mounting surface.
2. Route the cable through the drilled hole.
3. Connect the cable to a mixer or P.A. system.

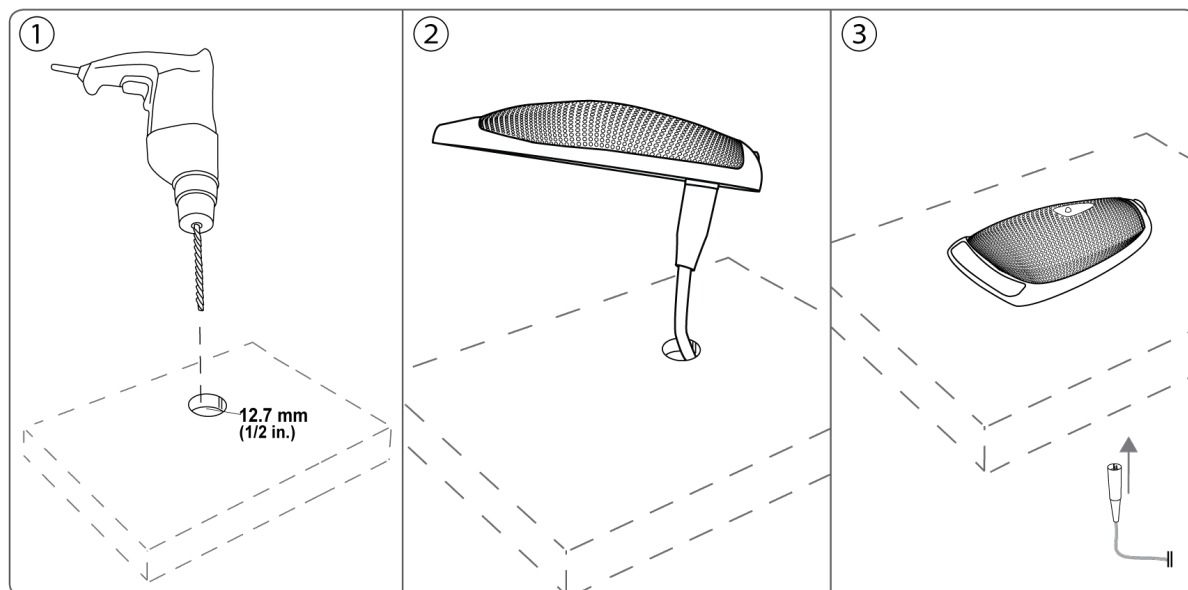

Pressure Sensitive Adhesive

1. Thoroughly clean the application area with the included alcohol wipe. Removing the dust will allow the microphone to adhere well.
2. Remove the adhesive backing and gently set the microphone into position.
3. Once the microphone is in position, firmly apply pressure to the microphone.

Note: The pressure sensitive adhesive will be extremely difficult to move once pressure has been applied.

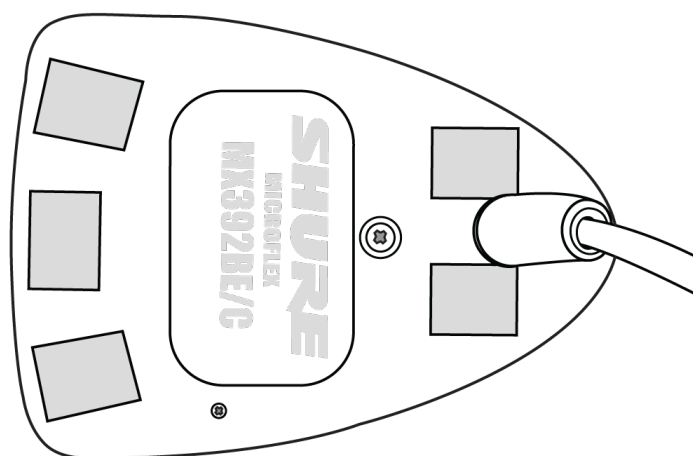

Bottom view of MX392BE/C with adhesive pads

Re-Routing Cable for Bottom Exit (If your MX392 is not BE configured)

1. Remove the grille.
2. Disconnect wires from screw terminals.
3. Grasp rubber boot within 1/2" of housing, using gas pliers. Rotate boot and cable ccw to remove connector from threaded "L" bracket.

4. Remove cable from microphone housing.
5. Insert cable through access hole in microphone base.
6. Insert cable connector through hole and thread it into "L" bracket.
7. If desired, rubber strain relief can be reattached to cable end or removed from cable before fastening it to bracket.
8. Re-connect wires to proper screw terminals on circuit board.
9. Insert supplied round rubber plug into unused side cable exit.
10. Reinstall grille and foam screen.
11. Insert cable through hole in mounting surface. Secure microphone to mounting surface.

Configuration

DIP Switches

Use the DIP switches to configure logic settings and mute button behavior.

The DIP switches are covered with a piece of clear tape at the factory. Remove tape to modify the switch settings.

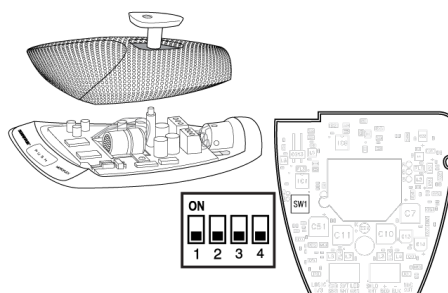

	OFF (factory default)	ON
1	Momentary	Toggle
2	Push-to-mute	Push-to-talk
3	Mute button enabled, LED illuminates when mic is active	Disable mute button (microphone always on), logic controls LED
4	--	--

Wiring Diagram

NOTE: Audio and logic ground are connected at microphone base.

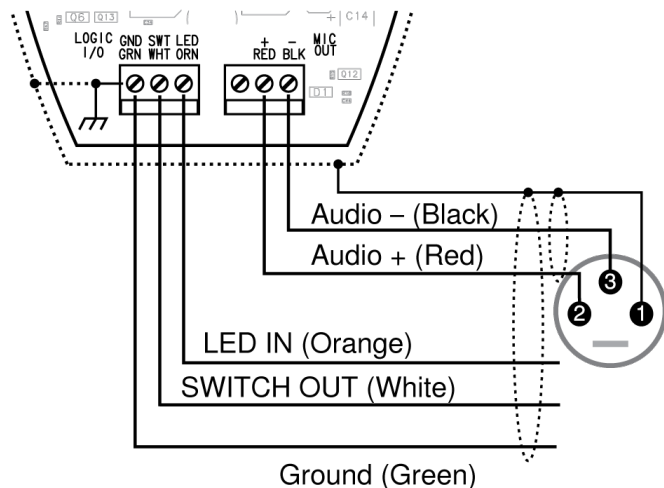

Mute Button Configuration

Use DIP switches 1 and 2 to configure the mute button, as follows.

*Be sure to set DIP switch 3 **off** (factory default) so that the mute button controls audio from the microphone.*

Switch Function	DIP Switch Setting
Momentary: push-to-mute (as shipped).	
Momentary: push-to-talk	
Toggle: (Push On/Push Off): Mic is active when powered on	

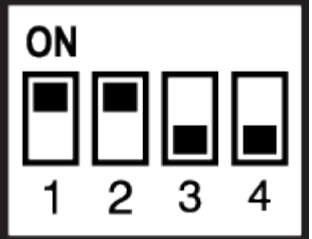
Switch Function	DIP Switch Setting
Toggle: (Push On/Push Off): Mic is mute when powered on	

Connecting to an Automatic Mixer

Use these settings if connecting the microphone to an automatic mixer or other device that mutes audio and controls the LED.

1. Connect logic leads to the automatic mixer. Connect the LED IN to the gate output to illuminate the LED when that channel is gated on.
2. Set DIP switch 3 on. This disables the mute button (the microphone passes audio regardless of whether the button is pressed or not).
3. Set DIP switch 1 to configure how the mute button sends SWITCH OUT logic:

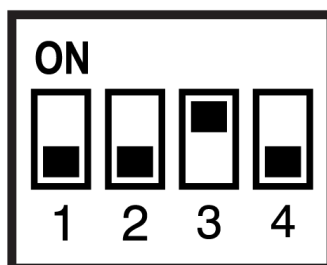

Momentary: push = 0 Vdc, release = 5 Vdc

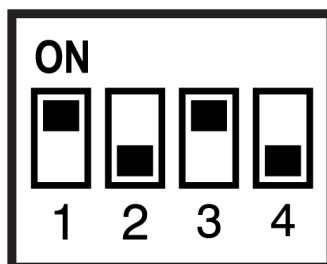

Toggle: initial = 5 Vdc, push = 0 Vdc

Logic Wiring

Green (LOGIC GROUND): Connects to the logic ground of an automatic mixer, switcher, or other equipment.

Orange (LED IN): Set DIP switch 3 on to use LED IN. When shorted to LOGIC GROUND, the LED turns on.

White (SWITCH OUT): Provides TTL logic (0 Vdc or 5 Vdc) in response to the mute button. Set DIP switch 1 for momentary or toggle. When phantom power is applied, logic initializes high (5 Vdc). DIP switch 2 has no effect on SWITCH OUT.

Changing SWITCH OUT to Always Momentary

Use the following modification in situations where your logic interface requires momentary closure of the SWITCH OUT, but you want the mute button to toggle the microphone (DIP switch 1 ON, 3 OFF):

1. Access the circuit board inside the microphone base.
2. Remove the resistor at R45 and reinstall it at location R46.

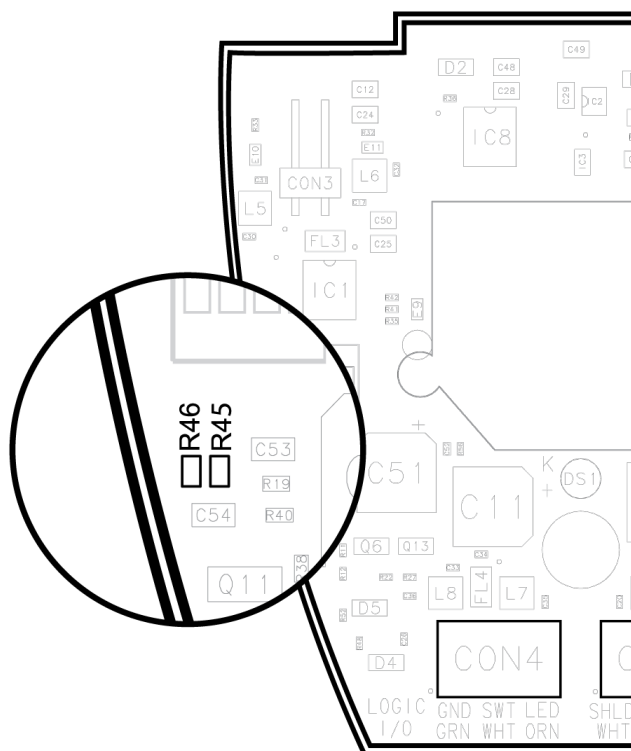

Painting

- A supplied plastic paint shield
- B retainer
- C grille
- D foam screen
- E supplied adhesive masking strip
- F supplied rubber plug

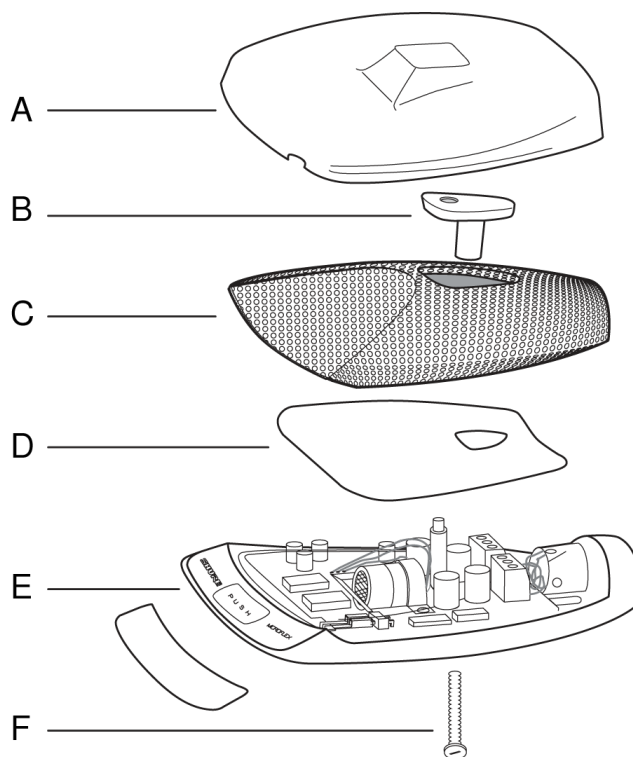

1. Remove foam screen from grille before painting
2. Clean surfaces to be painted with denatured alcohol or naphtha.
3. To avoid filling grille holes, apply paint in thin layers.
4. **Important:** Use fine sandpaper to remove paint from the bottom edges of the grille. This ensures electrical continuity for proper shielding.

Specifications

All measurements taken with microphone mounted on a wooden surface (76 x 76 cm)

Type

Electret Condenser

Frequency Response

50–17000 Hz

Polar Pattern

MX392/C, MX392BE/C, MX393/C	Cardioid
MX392/S, MX392BE/S, MX393/S	Supercardioid
MX392/O, MX392BE/O, MX393/O	Omnidirectional

Output Impedance180 Ω **Output Configuration**

Active Balanced

Sensitivity*@ 1 kHz, open circuit voltage*

Cardioid	-30 dBV/Pa
Supercardioid	-28 dBV/Pa
Omnidirectional	-22 dBV/Pa

1 Pa=94 dB SPL

Maximum SPL*1 kHz at 1% THD, 1 k Ω load*

Cardioid	119 dB
Supercardioid	118 dB
Omnidirectional	111 dB

Self Noise*A-weighted*

Cardioid	23 dB SPL
Supercardioid	21 dB SPL
Omnidirectional	15 dB SPL

Signal-to-Noise Ratio*Ref. 94 dB SPL at 1 kHz*

Cardioid	71 dB
Supercardioid	73 dB
Omnidirectional	80 dB

Dynamic Range*1 k Ω load, @ 1 kHz*

96 dB

Common Mode Rejection*10 Hz to 100 kHz*

45 dB, minimum

Clipping Level*at 1% THD*

-6 dBV (0.5 V)

Polarity

Positive sound pressure on diaphragm produces positive voltage on pin 2 relative to pin 3 of output XLR connector

Mute Switch

50–20000 Hz

–50 dB minimum

Logic Connections

LED IN	Active low ($\leq 1.0V$), TTL compatible. Absolute maximum voltage: $-0.7V$ to $50V$.
LOGIC-OUT	Active low ($\leq 0.5V$), sinks up to $20mA$, TTL compatible. Absolute maximum voltage: $-0.7V$ to $24V$ (up to $50V$ through $3k\Omega$).

Cable

MX392	$3\frac{1}{2}$ m (12 ft) attached cable with shielded audio pair and three conductors for logic control, unterminated
MX392BE	$3\frac{1}{2}$ m (12 ft) attached cable with shielded audio pair and three conductors for logic control, unterminated, bottom exit
MX393	$3\frac{1}{2}$ m (12 ft) detachable cable with 3-pin audio connector

Weight

172 g (0.38 lbs)

Environmental Conditions

Operating Temperature	$-18-57$ °C($0-135$ °F)
Storage Temperature	$-29-74$ °C($-20-165$ °F)
Relative Humidity	0-95%

Power Requirements

11-52V DC , 2.0 mA

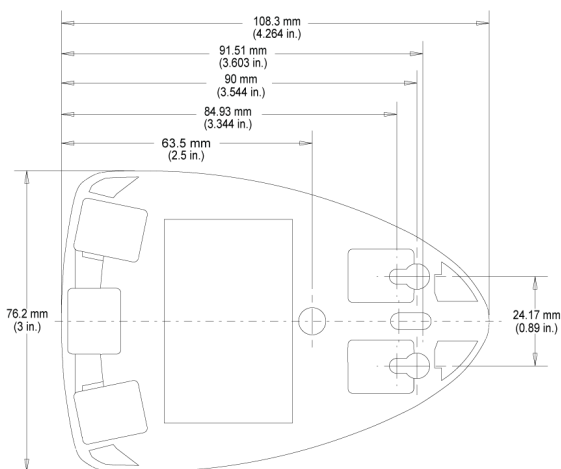
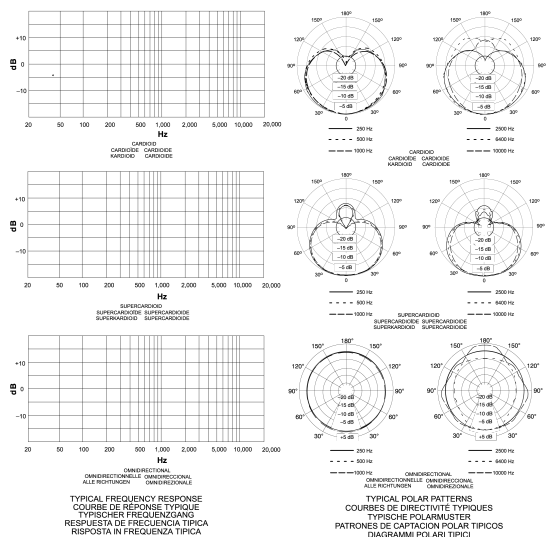

Furnished Accessories

Paint Mask	80C514
Switch Paint Mask	80A541
Set of 5 rubber pads with adhesive	RPM470

Certifications

Meets essential requirements of all applicable European Directives.

Eligible for CE marking.

The CE Declaration of Conformity can be obtained from Shure Incorporated or any of its European representatives. For contact information please visit www.shure.com

The CE Declaration of Conformity can be obtained from: www.shure.com/europe/compliance

Authorized European representative:

Shure Europe GmbH

Headquarters Europe, Middle East & Africa

Department: EMEA Approval

Jakob-Dieffenbacher-Str. 12

75031 Eppingen, Germany

Phone: +49-7262-92 49 0

Fax: +49-7262-92 49 11 4

Email: info@shure.de