

DCR822

Compact Dual Channel Digital Receiver

DCR822-A1B1, DCR822-B1C1, DCR822-941, DCR822-961



scan for informational product video



Quick Start Summary

The following checklist includes the minimum required settings to start using the receiver.

- Connect power to the receiver or install batteries.
- Set the COMPAT (compatibility) mode for the transmitters to be used.
- Choose clean frequencies for your receiver channels using SmartTune or RF scan.
- Set transmitters on the matching frequencies (see your transmitter manual) or use IR sync.
- Verify transmitters are set to the same compatibility mode as the receiver (see your transmitter manual).
- Adjust transmitter input gain to match voice level and mic position (see your transmitter manual).
- Select audio output type to match camera or mixer input (analog or AES3 digital).
- Adjust receiver output level as needed for the camera or mixer input level desired.
- Turn on transmitter RF signals (see your transmitter manual).



Fill in for your records:

Serial Number:

Purchase Date:

Table of Contents

General Technical Description	4	Supplied Parts and Accessories	25
Compatibility with microSDHC memory cards.....	6	Optional Parts and Accessories.....	25
Front Panel Controls and Functions.....	7	Troubleshooting.....	27
MENU/SELECT Button.....	7	Specifications and Features.....	28
PWR/BACK Button.....	7	Service and Repair	29
Up/Down Arrow Buttons.....	7	Returning Units for Repair	29
IR (infrared) Port	7		
microSDHC Memory Card Port	7		
Antenna Port (2).....	7		
Rear Panel Features.....	7		
TA3 Audio Output Jacks	7		
Power Input Jack	7		
USB Port.....	7		
Battery Compartment	7		
LCD Main Window	8		
Navigating the Menus	8		
Main Window Screens	8		
Replacing the Batteries	9		
DCR822 LCD Menu Map	10		
Menu Item Descriptions.....	13		
RF Setup.....	13		
Tuning Groups.....	13		
Named Group Entries (Party Dialing).....	14		
Scan/Scan Zoom.....	14		
Group Edit	14		
Using Diversity Modes	14		
Audio Setup.....	15		
Compat Mode.....	15		
SD Card Settings.....	16		
IR & Keys Menu	17		
Encryption Key Management	18		
Settings Menu	18		
Antenna Mounting and Orientation	19		
Antenna/Block Reference Table.....	21		
Installation and Operating Instructions.....	22		
Scan Function/Finding Clear Frequencies.....	22		
Locking and Unlocking the Front Panel Controls...	22		
Firmware Update	23		
DCR822 and Wireless Designer	23		
Diagnostics	24		
Pilot Tone Bypass.....	24		

Our accessories and parts online store for US customers is now open:

<https://store.lectrosionics.com/>

DCR822 Block Diagram

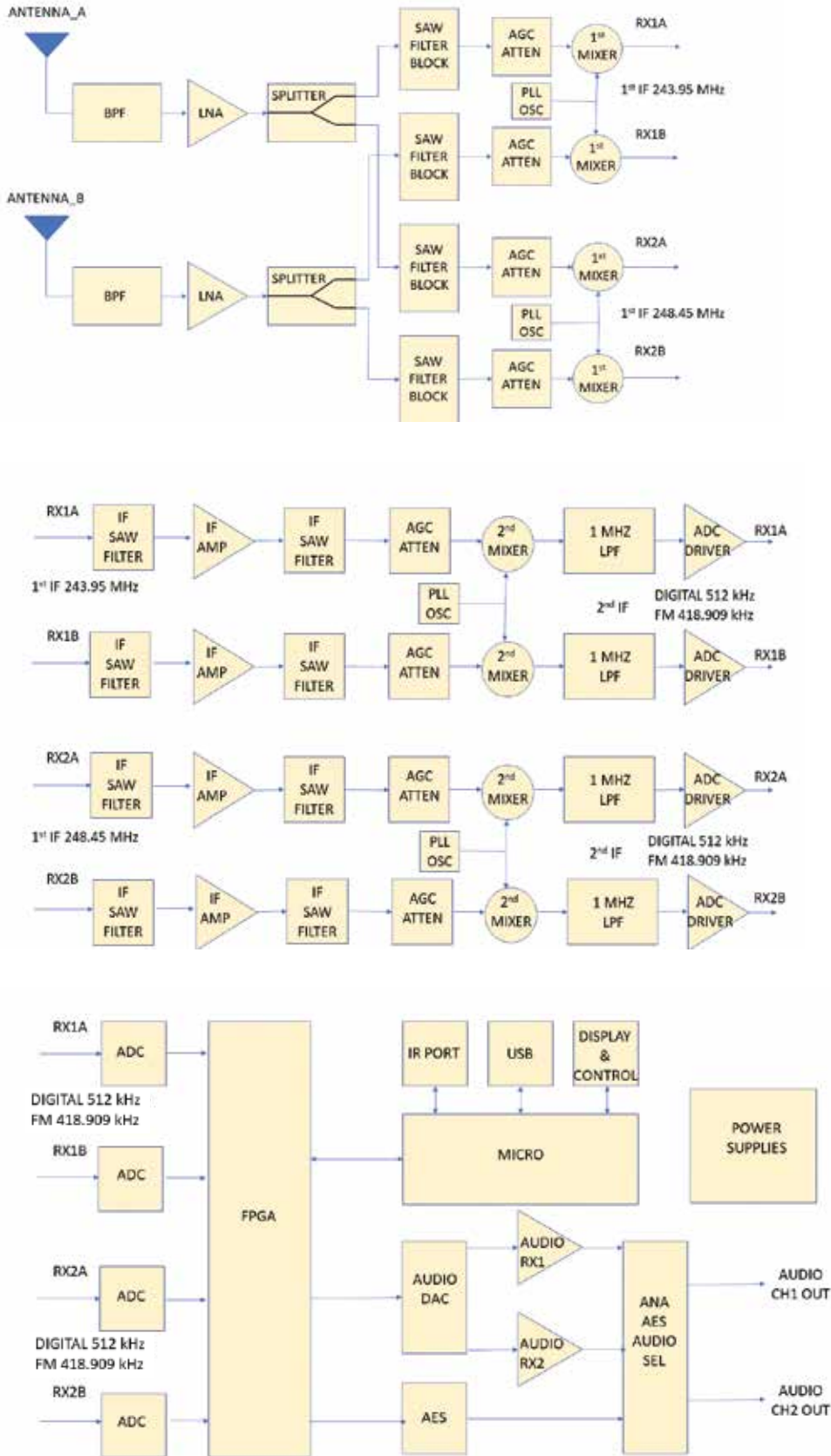

The DCR822 digital 2-channel receiver is the true successor to the venerable UCR411a - a dual-channel package in the same size - and represents state-of-the-art RF performance with Vector Diversity (an advanced type of true diversity) and extremely robust front-end architecture, bringing the highest level of RF and audio performance to field and location production.

Extremely high Third Order Intercept (IP3) performance of +15 dBm, 24-bit/48 kHz audio performance, and AES-256 CTR mode encryption ensure that professionals in all audio disciplines have the tools needed to get the job done, even in extremely tough environments. On-board recording in .WAV (BWF) format via microSDHC card give this receiver unique possibilities for different workflows.

Compatibility Modes

The DCR822 receiver was designed to operate with Lectrosonics digital transmitters from the D2, DCH and M2 series. The receiver is also backward compatible with Digital Hybrid Wireless® transmitters including those with NA Hybrid, NU Hybrid, JA HYBRID and EU Hybrid modes.

Encryption

The DCR822 receiver features AES 256-bit, CTR mode encryption, with 4 different key policies available.

Vector Diversity Reception

The DCR822 technology with Lectrosonics Vector Diversity (an advanced version of true diversity) minimizes dropouts in situations where multi-path reflections can cause serious problems. Traditional true diversity or ratio diversity methods work well for FM and Hybrid systems but fall short of the ideal for today's digital receivers. The DCR822's Vector Diversity subsystem delivers clean, artifact-free performance by combining the two receiver signals via a unique phase-matching system for maximum RF signal to noise.

RF Frequency Tracking Front-End and Mixer

In addition to the extremely high IP3 capability of the receiver, to significantly reduce unwanted interference and intermodulation problems, the DCR822 has a frequency selective front-end section that tracks and tunes to the desired signal frequency and rejects unwanted interfering signals. The low noise, high current RF amplifier was designed with feedback regulation for stability and precise gain in order to handle stronger RF signals without output overload. This produces a robust front-end that is as selective as fixed single frequency designs and is suitable for use in close proximity to other receivers and transmitters commonly used in field production bag systems.

Smart Noise Reduction (SmartNR™)

The DCR822 has been meticulously designed using the best available low noise components and techniques. Nonetheless, the wide dynamic range of digital and

Hybrid transmission technology, combined with flat response to 20 kHz, makes it possible to hear the -120 dBV noise floor in the transmitter's mic preamp, or the (usually) greater noise from the lav microphone itself. (To put this in perspective, the noise generated by the recommended 4k bias resistor of many electret lavalier mics is -119 dBV and the noise level of the microphone's electronics is much higher.) In order to reduce this noise and thus increase the effective dynamic range of the system, the DCR822 is equipped with a selectable Smart Noise Reduction algorithm, which removes hiss without sacrificing high frequency response.

The Smart Noise Reduction algorithm works by attenuating only those portions of the audio signal that fit a statistical profile for randomness or "electronic hiss." Desired high frequency signals having some coherence such as speech sibilance and tones are not affected.

The Smart Noise Reduction algorithm has three modes - **OFF/NORMAL/FULL** - selectable from a user setup screen. When switched **OFF** (the default setting for digital compat modes) no noise reduction is performed and complete transparency is preserved. All signals presented to the transmitter's front end, including any faint microphone hiss, will be faithfully reproduced at the receiver. When switched to **NORMAL**, (the factory default setting for Hybrid modes) enough noise reduction is applied to remove most of the hiss from the mic preamp and some of the hiss from lavalier microphones. The noise reduction benefit is dramatic in this position, yet the degree of transparency maintained is exceptional. When switched to **FULL**, enough noise reduction is applied to remove most of the hiss from nearly any signal source of reasonable quality, assuming levels are set properly at the transmitter. This additional noise reduction comes at the cost of some transparency for low-level room noise, yet the algorithm remains undetectable under most circumstances.

Audio Output Level

A setup screen is provided for adjusting the audio output level in 1 dB increments from -50 to +7 dBu using the front panel **MENU/SEL**, **UP**, and **DOWN** buttons.

Test Tone

To assist in matching the audio levels of equipment connected to the DCR822, a 1 kHz audio test tone, adjustable from -50 to +7 dBu in 1 dB increments, is available at the outputs. If using AES3 outputs, the level is fixed and cannot be adjusted.

Batteries

The DCR822 can operate on four disposable, 1.5VDC AA Lithium batteries (recommended). Alkaline is not advised.

Power Supply

The DCR822 may also be operated from an external DC power source (*see Specifications & Features section for allowed voltages.*) The receiver has a built-in Poly-Fuse for protection. This fuse automatically resets if the power supply is disconnected for about 15 sec. The power sec-

tion also has protection circuits that prevent damage to the receiver if a positive ground power source is applied.

OLED Display

The display has four primary “home” windows. Pressing the Front Panel **PWR/BACK** button steps through each of these windows. Pages 8 and 9 show illustrations and features of each.

After power is turned off and back on again, the unit defaults to the Main window and to the most recent frequencies, audio levels, transmitter battery conditions, and other user settings. These settings are retained even if the batteries are removed. The display illumination can be set to time out in 5 seconds, 30 seconds, or never.

Recorder Function

The DCR822 has a built in recording function for use in situations where the absolute minimum equipment is necessary, or as a backup to the main recorder system.

The recorder samples at 48kHz rate with a 24 bit sample depth. The micro SDHC card also offers easy firmware update capabilities without the need for a USB cable or driver issues.

Clock Function

The DCR822 has a built-in calendar and clock that are saved with power down. If the batteries are removed from the unit, the DCR822 “remembers” where it left off and resumes time and date counts from that point.

Power Off

When the Front Panel Power/Back button is pressed for several seconds, the audio output is instantly muted (squelched) and the message “POWERING OFF...” is displayed briefly before the receiver switches off.

Compatibility with microSDHC memory cards

Please note that the DCR822 is designed for use with **microSDHC memory cards**. There are several types of SD card standards (as of this writing) based on capacity (storage in GB).

SDSC: standard capacity, up to and including 2 GB – **DO NOT USE!**

SDHC: high capacity, more than 2 GB and up to and including 32 GB – **USE THIS TYPE.**

SDXC: extended capacity, more than 32 GB and up to and including 2 TB – **DO NOT USE!**

SDUC: extended capacity, more than 2TB and up to and including 128 TB – **DO NOT USE!**

The larger XC and UC cards use a different formatting method and bus structure and are NOT compatible with the recorder. These are typically used with later generation video systems and cameras for image applications (video and high resolution, high speed photography).

ONLY microSDHC memory cards should be used. They are available in capacities from 4GB to 32GB. Look for the Speed Class 10 cards (as indicated by a C wrapped around the number 10), or the UHS Speed Class I cards (as indicated by the numeral 1 inside a U symbol). Also note the microSDHC Logo.

If you are switching to a new brand or source of card, we always suggest testing first before using the card on a critical application.

The following markings will appear on compatible memory cards. One or all of the markings will appear on the card housing and the packaging.

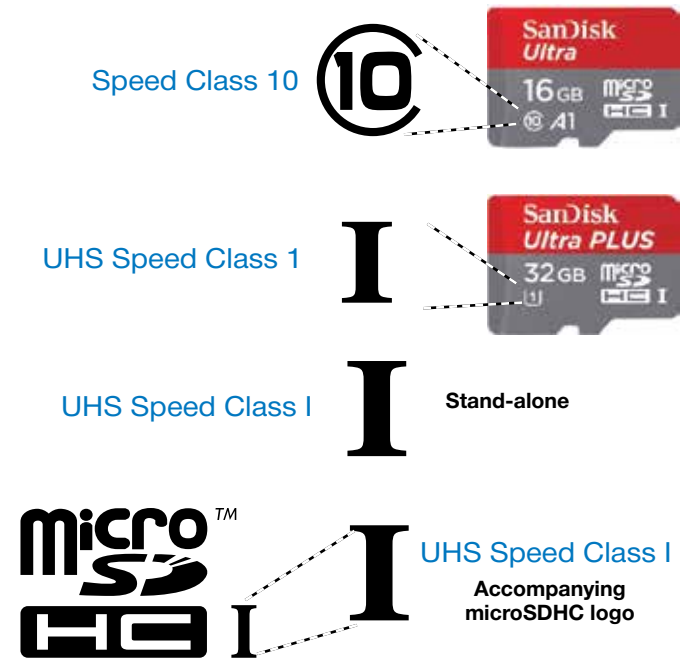

microSDHC Logo is a trademark of SD-3C, LLC

NOTE: The default format for a card formatted on a computer is always DATA. DATA format is needed when downloading files for Firmware updates or for saving frequency groups. When formatting a card in the DCR822 for audio applications, the DCR822 will ask if you are formatting for audio, in which case, any files on the card will be lost.

Front Panel Controls and Functions

MENU/SEL Button

The **MENU** button accesses the available menus and selects the desired setting.

PWR/BACK Button

The **PWR/BACK** button is used to turn the receiver on and off. When browsing menus and making changes to settings, press **PWR/BACK** to return to previous menu.

Up/Down Arrow Buttons

The **UP/DOWN** buttons are used to scroll or input the various options within each menu selection.

IR (infrared) Port

Settings can be transferred between transmitter and receiver or receiver and receiver.

microSDHC Memory Card Port



Rear Panel Features

TA3 Audio Output Jacks

The DCR822 uses a standard TA3 configuration with pin 2 "positive." The audio output is balanced but not floating, so an unbalanced signal is available using pin 1 as ground and pin 2 as signal, leaving pin 3 open (audio level will be 6 dB lower than balanced).

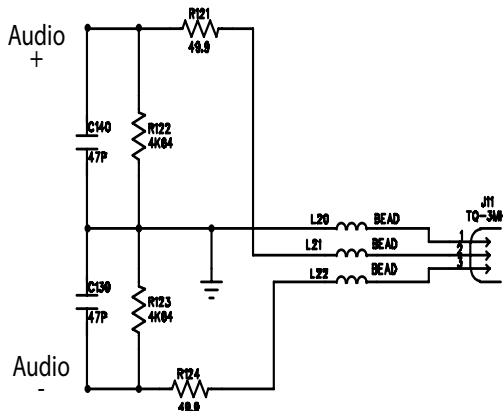

Power Input Jack

The power input jack can accept 9-17 VDC - the center pin is positive and sleeve is ground. The input is diode protected to prevent damage if the power is applied with reversed polarity, and the unit will not work until the reversed polarity condition is corrected.

USB Port

The microB USB port can be used to connect the DCR822 to the Lectrosonics Wireless Designer software (pending; capability will be built into a future firmware update).



Battery Compartment

Four AA batteries are installed as marked on the side panel of the receiver.

The battery door is hinged and remains attached to the housing when open. The specially-designed latch snaps and locks into place for security when closed.



LCD Main Window

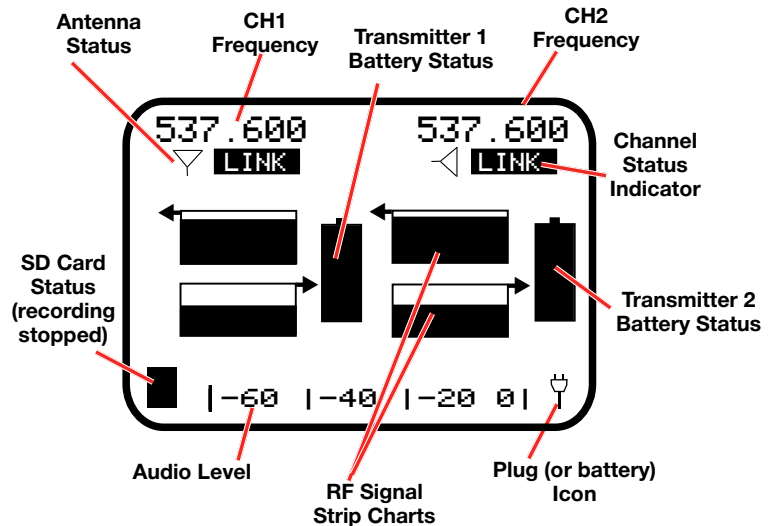

Navigating the Menus

From the Main Window, press **MENU/SEL** to enter the menu, then navigate with the **UP** and **DOWN** arrows to highlight the desired setup item. Press **MENU/SEL** to enter the setup screen for that item. Refer to the menu map on pages 10-12.

Main Window Screens

The Main Window displays information concerning the RF levels at each antenna per channel, audio modulation levels, the condition of the Pilot Tone (Hybrid) or Link (digital), and battery conditions for both the receiver and the associated transmitters. It is also the access portal to menu selections for setting up the receiver and searching for clear frequency channels. (See *Menu Selections from Main window and Frequency Scan Mode*). The **PWR/BACK** button will cycle the display through four different, additional screen configurations, containing various combinations of transmitter names, RF signal strength meters and audio meters, depending on user preference.

- **Receiver Battery icon** changes to a plug icon when external power is supplied.
- **SD Card Status:** No card, card error, data card, stopped (ready to record), recording.
- **Antenna Icons:** Status of the vector diversity system.
- **Transmitter Battery Status Icons:** Appear when the receiver's battery status is known and can take on different appearances, depending on user settings.
- **RF Signal Strength Strip Charts:** RF signal strength indicators.
- **Channel Status Indicator:** Pilot tone, link and encryption system status.
- **Keypad Shortcut:** Can start or stop recording from the Main Window: **MENU+UP** to begin recording and **MENU+DOWN** to stop recording.

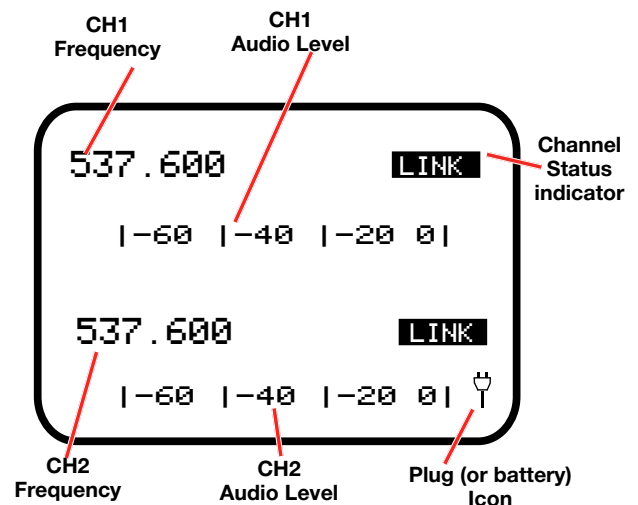
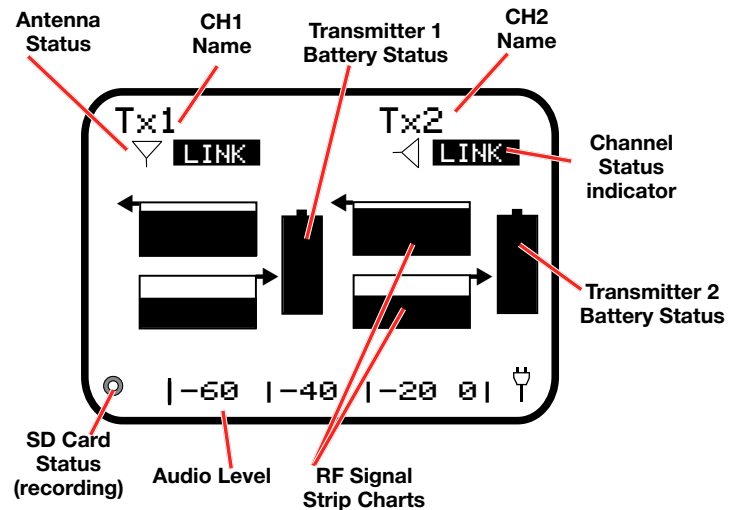

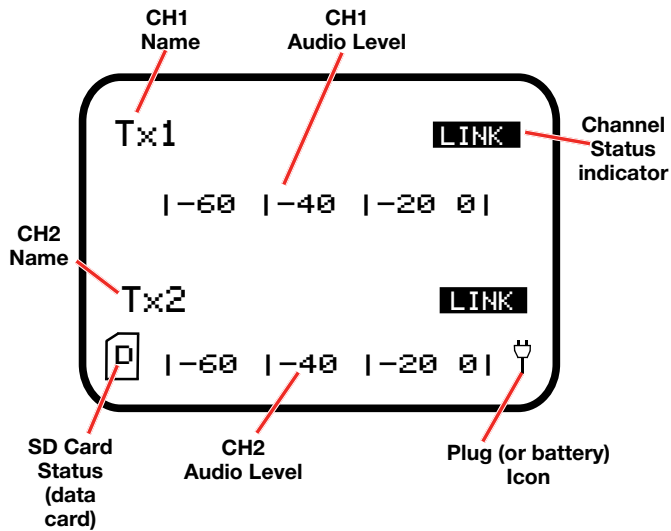

NOTE: If Link Indicator is flashing, this indicates that the key or compat mode is invalid.

NOTE: The backlight will automatically come on with low battery warnings.

Replacing the Batteries

Lift the battery door to unlatch, push slightly forward and open it.

Observe the battery orientation markings on the side of the unit.



Depress the batteries slightly to allow the door to close, then press with down firmly while pushing back towards the DC connector to latch the door closed. The battery contacts are spring loaded to maintain constant pressure. The door will snap into place for security when it is fully closed.



CAUTION: Be sure to remove batteries as soon as possible after they are depleted.

DCR822 LCD Menu Map

The menus presented on the LCD are arranged in a straightforward manner, with those that are likely to be used more often located at the top of the tree.

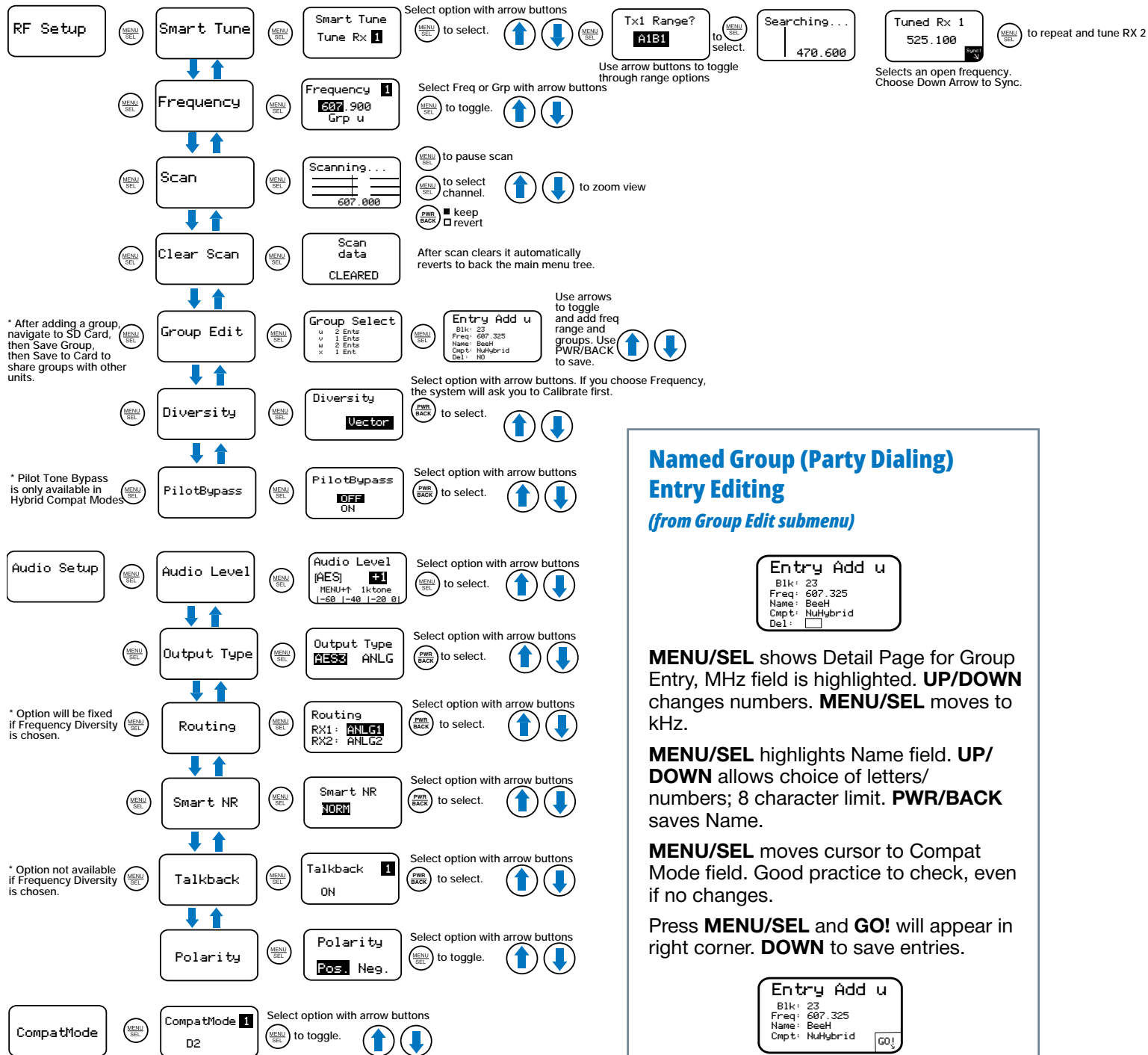

DCR822 LCD Menu Map

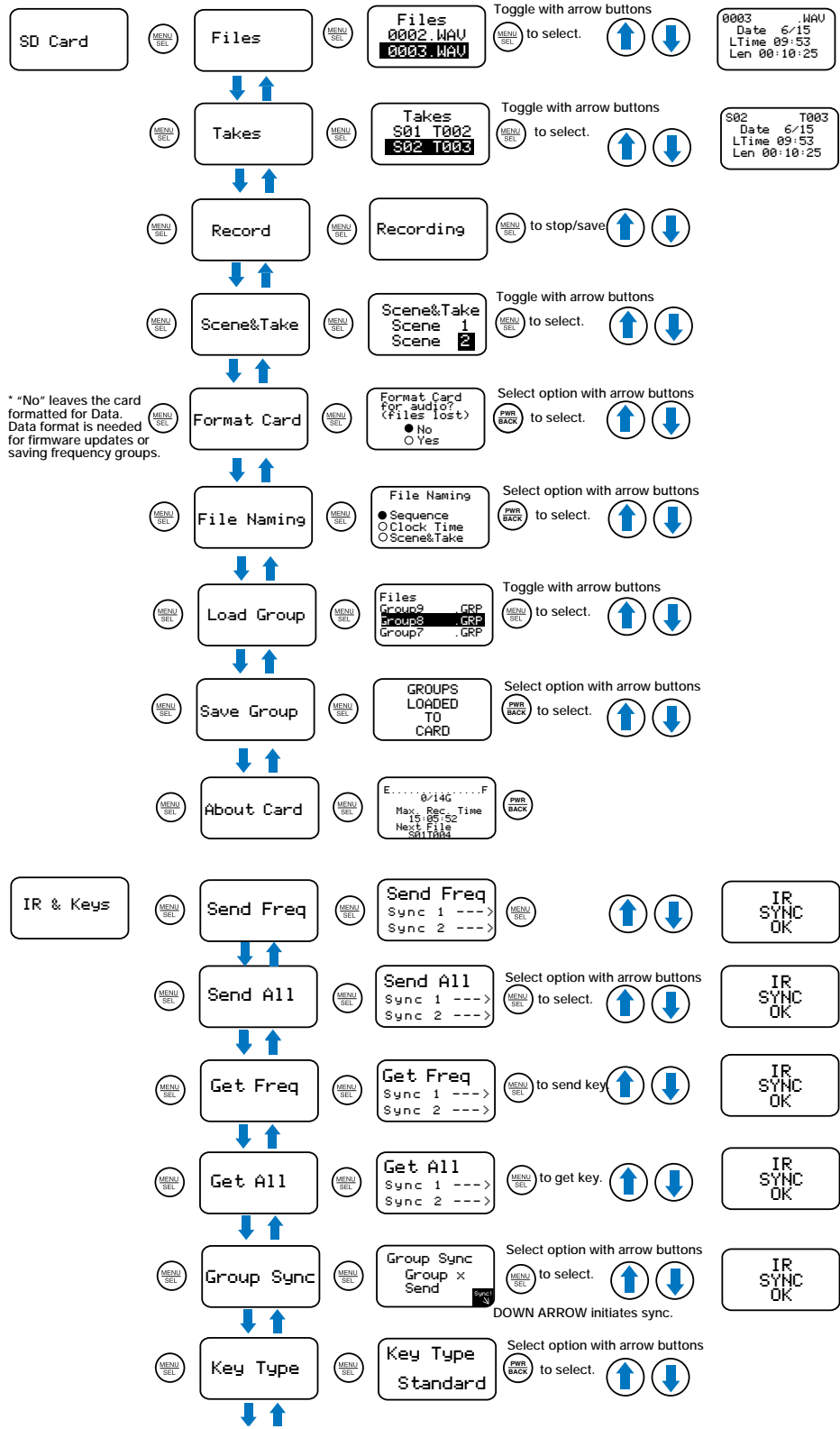

DCR822 LCD Menu Map

* If an Encryption Key exists, this option will be Wipe Key, providing the option to delete and start over.

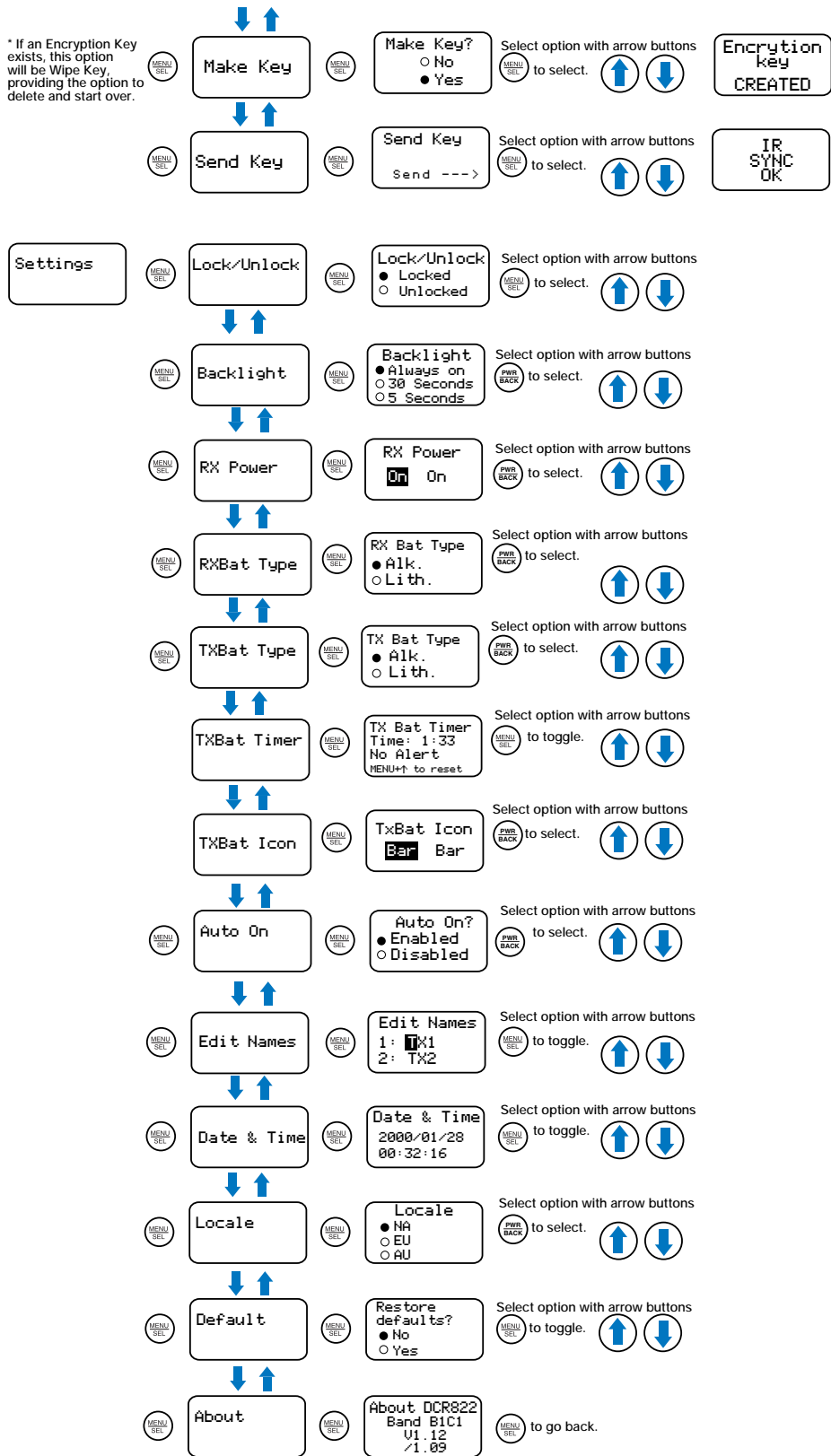

Menu Item Descriptions

RF Setup

Finding Clear Frequencies with SmartTune:

SmartTune is the easiest and fastest way to scan the local RF spectrum and find clear operating frequencies. The receiver will scan through the selected tuning bandwidth and automatically find “empty” areas within the tuning range that have little or no RF energy. The receiver will then be set to a frequency within an empty area and prompt you to continue or use the IR function to sync to a transmitter.

Note: Pressing **BACK** during an active scan will restore the operating frequency to what it was set at pre-scan.

Transmit frequency range is compatibility mode dependent (see *Compat Mode* for further details). *Tune Receiver 1* is the first screen you will see when you enter SmartTune. After selecting either Tune Rx1 or 2, using the **UP/DOWN** buttons, press **MENU/SEL** to open the **TX Range?** page, then use the **UP/DOWN** buttons to select the frequency range of the transmitter.

After choosing the band, the unit will scan the available frequency and choose the frequency with the lowest interference and will display it as shown, with a “Sync!” icon in the lower right corner of the screen.

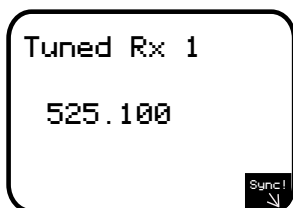

Face the transmitter’s IR port within a foot of the receiver’s IR port and press the **DOWN** button to begin the sync. In digital compat modes, if the sync is successful, the message “IR Sync OK” will appear on screen. If unsuccessful, the message will show “IR Sync Failed”. For Hybrid compat modes, “Sync!” at the lower right will blink, but the sync status will only show on the transmitter’s display. the transmitter’s IR port within a foot of the receiver’s IR port and press the **DOWN** button to begin the sync. If sync is successful, the screen will display “IR Sync OK.” If unsuccessful, the screen will display “IR Sync Failed.”

After the sync of Channel 1, choose **MENU/SEL** and the screen will ask *Do RX 2 Next?* Use the **UP/DOWN** buttons to toggle between Yes and No; use **MENU/SEL** to confirm. The screen will ask if you have Transmitter 1 on. This ensures that the transmitters are tuned in a way that they don’t interfere with each other.

It will then ask for *TX2 Range?* After you choose your range, choose **MENU/SEL** and the DCR822 will search

for a clear frequency. It will ask to sync. Press the **DOWN** button to sync the transmitter to the receiver. When complete, press **PWR/BACK** to return to the **MAIN SCREEN**.

Frequency:

Allows manual selection or group tuning of the operating frequency for each channel. The frequency setup screen has different fields depending on mode selected. In digital modes, with no tuning group selected, the frequency setup page has four fields: receiver name, MHz, kHz, and group selector. In Hybrid modes, with no tuning group selected, the page has six fields: receiver name, block selector, legacy hex code, MHz, kHz, and group selector. The block selector can be used for block disambiguation for any frequencies that overlap between blocks 470 and 19, or between blocks 23-24 and 606.

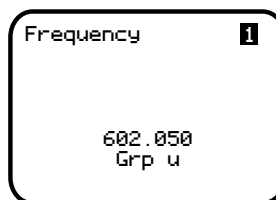

Digital Mode

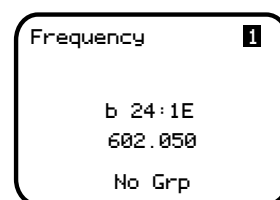

Hybrid Mode

To manually tune: start by selecting either Channel 1 or 2 in the upper right corner. Then, press **MENU/SEL** to select the desired field to edit, using the **UP** or **DOWN** buttons. MHz value can be changed in increments of 1 MHz by pressing the **UP** or **DOWN** buttons. To keep the selected value, press the **MENU/SEL** button. The kHz value can be changed in increments of 25 kHz by pressing the **UP** or **DOWN** buttons. Pressing **MENU/SEL** and **UP** or **DOWN** at the same time tunes in larger steps. In the MHz field, in 10 MHz steps; in the kHz field, in 100 kHz steps.

Tuning Groups:

Tuning groups are an important feature within the RF Setup menu that allow the user to create, store, share, recall, and use lists of frequencies with associated names and compat modes, quickly and easily. Four tuning groups are available, each containing 32 frequencies. See *Group Edit* for how to set up and edit these tuning groups. When a tuning group is assigned on the Frequency page, the tunable frequencies are limited to those contained in the group. Press **MENU/SEL** to move the cursor among the available options, and **UP** and **DOWN** buttons to change values.

First, select receiver 1-4. Move the cursor again to the group setting. Use the **UP** or **DOWN** buttons to select among the four groups u, v, w, or x. Press **MENU/SEL** again to move the cursor to the Name selector. Use the **UP** or **DOWN** buttons to scroll among the available names in the group, in *alphabetical* order, and the associated group frequency will change to match. Press **MENU/SEL** to move the cursor to the Freq selector. Use the **UP** or **DOWN** arrows to scroll the available frequencies in the group in *numerical* order.

NOTE: If the frequency is blinking, it means that the currently tuned frequency is not in the selected group. If it is steady, it means that the currently tuned frequency is in the selected group. Choose No Group to exit the group tuning mode and thus have access to any frequencies within the tuning range of the receiver.

To add or remove entries from a tuning group, see *Group Edit*.

NOTE: If the frequency is blinking, it means that the currently tuned frequency is not in the selected group. If it is steady, it means that the currently tuned frequency is in the selected group. Choose No Group to exit the group tuning mode and thus have access to any frequencies within the tuning range of the receiver.

Named Group Entries (Party Dialing)

Entries created in Group Edit can now contain information including the frequency, compatibility mode, and an alpha-numeric combination, or name, up to 8 characters. These programmed entries can be shared between devices that support this feature (DSR4, DCR822, DSR). This feature, especially combined with the frequency page shortcut (press **UP** and **DOWN** buttons together for 1 second from any menu location) can save time an effort when managing large channel counts on location.

NOTE: If the Compat mode shows “no change,” this means that when this group entry is pulled up in the Frequency page, whatever Compat mode was previously set for that receiver channel (including from a previous Group Entry), it will remain unchanged. If you’re using all of the same type of transmitter (all DBSMs, etc.), this setting will work well. However, for frequency groups of mixed transmitter types (such as SMWBs and DBSMs), it is recommended to enter the Compat Mode for every group entry, to avoid issues later.



Scan:

Scans for an open frequency and shows a graphic representation of RF energy in the area, by frequency. Press **MENU/SEL** to begin the scan. You can pause the scan by pressing **MENU/SEL** a second time. Pressing **MENU/SEL** again changes receiver channels.

Scan Zoom:

To zoom the screen, first pause the screen. Press the **UP+DOWN** buttons to see another scan. Pressing **MENU/SEL** clears changes. To exit the zoomed view, press **UP+DOWN** again to return to the previous screen.

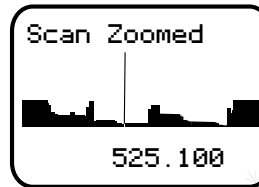

Clear Scan:

Clears scan results. Highlight **CLEAR SCAN** in the menu, then press **MENU/SEL**. The screen will quickly show *Scan Data Cleared*.

Group Edit:

Allows the user to add, edit, or delete entries within the available tuning groups. Use the **UP** or **DOWN** arrow buttons to highlight which group to edit, then press **MENU/SEL**. If the selected group is empty, “New Entry...” will be highlighted. Press **MENU/SEL** to create a new entry. Use **MENU/SEL** to move the cursor among the editable fields. For MHz and kHz, use the **UP** or **DOWN** buttons to select the desired numerical values.

With the Name field highlighted, use the **UP** or **DOWN** buttons to choose the desired letters or numbers, and the **MENU/SEL** button to move the cursor to the next slot in the name field. Up to 8 characters are available. When the name is complete, press the **BACK** button. Then, press **MENU/SEL** to move the cursor to the Compat Mode selection. Use the **UP** or **DOWN** buttons to select the desired compat mode for this entry.

Press **MENU/SEL** and “GO!” will appear at the lower right corner of the display. Press the **DOWN** button to save the entry.

NOTE: For any frequencies in a block overlap area (blocks 470/19, 23/606/24) and a Hybrid mode is selected, it is important to also define which block is desired for proper operation, otherwise there may be a pilot tone conflict.

Editing Existing Entries:

Editing group entries is done the same way they were created, with the exception of the “Del” (delete) box. To delete an entry, press **MENU/SEL** to navigate to the delete box, then use the **UP** or **DOWN** buttons to select or unselect, press **MENU/SEL** and “GO!” will appear at the bottom right. Press the **DOWN** button to complete.

Diversity:

Choose between: Vector or Frequency. Diversity modes safeguard against loss of audio signal caused by Multipath. If you choose Frequency, the system will ask you to calibrate. The calibration step is necessary for matching audio levels between channels for proper orientation.

Using Diversity Modes

Two diversity reception modes are available:

- **Vector Diversity** uses one receiver module per audio channel.
- **Frequency Diversity** uses two receiver channels and two transmitters per audio channel. The second receiver will automatically be set to the same Compat Mode as CH1 when this diversity mode is selected.

Vector Diversity

Vector Diversity works by expressing the signal from each antenna in angle and magnitude (vector). This makes it possible to continuously rotate one of the vectors mathematically so the angles match and the signals can be combined constructively. In this way, all the energy that is available at both antennas is always fully contributing to the receiver's performance.

Frequency Diversity

Frequency Diversity differs from vector diversity in that it uses both receiver channels and two transmitters operating on different frequencies. The purpose of this mode is to have redundancy in the system for critical productions, such as live television, to guard against failures caused by dead batteries and multipath dropouts.

Frequency Diversity requires that the levels of the two audio channels to be closely matched to avoid audible level changes as the blending action takes place. In order for this blending to work properly, a special test mode helps to get the transmitter levels exactly matched.

Note: In Frequency Diversity mode, both transmitters must be the same type (usually the same model). The microphones must also be placed very close together to minimize comb filtering.



The DCR822 allows null testing with a special calibration mode as shown on the display. When the display shows “calibrate,” it should be possible to achieve a null. Calibration is automatically activated on selection of the Frequency Diversity mode, and

automatically cancelled on exiting the diversity setup page. Calibration can be toggled on and off for testing but will revert to Operate mode on exiting the diversity setup page.



To prepare for operation in the Frequency Diversity mode, make the following adjustments:

1. Set up the transmitters according to their instructions. Verify that both transmitters are set to the

same audio polarity, and set to the same input gain level. Turn them on to transmit, and verify that audio and RF signals are present at the receiver. Place the two microphone elements as closely together as possible, and place them where there is a steady source of sound. Pink noise from a loudspeaker, headphone, or smartphone is ideal. Make sure it is loud enough to modulate the receiver audio to the middle of the range on both channels.

2. Connect a headphone amplifier to one of the audio outputs on the DCR822 (in Frequency Diversity mode, the resulting blended audio is mirrored on both outputs). In the photograph, an MTCR is used. Plug a set of headphones into the amplifier jack to monitor the blended output.
3. In the “Calibrate” mode, the two receiver channels are placed out of polarity from each other. While listening to the blended output, adjust the gain control on one of the transmitters so that the audio level drops significantly (nulls) as the two channels cancel each other. For the best performance in Frequency Diversity mode, adjust the mic gain up and down on one transmitter as described, listening for the deepest null.
4. Once completed, Press the **PWR/BACK** button to exit this screen, which will automatically change from “Calibrate” to “Operate”. While still on the Diversity selection page, you can select “Calibrate” with the **MENU/SEL** button, then change to “Operate” by pressing the **UP** or **DOWN** buttons.

Pilot Bypass:

Allows the user to bypass the pilot tone on each channel while in a Hybrid compat mode and defeats the pilot tone squelch when on (no pilot tone is required). “Off” means that pilot tone must be present to allow audio output. This setting is compatibility mode dependent. If this option is not available for the mode you have chosen, the screen will show *N/A*.

WARNING: Without a carrier present (a transmitter on), the audio will be unsquelched noise.

Audio Setup

Audio Level:

Allows user to set Audio Output Level per channel and allows user to enable 1kHz audio tone for level setting. This setting is Output Type dependent. If AES is chosen, there are no adjustments available.

Output Type:

Allows user to choose output for each channel, analog or AES3

Routing:

Allows user to choose where to send RX1 and RX2, to either audio output channel or both.

Smart NR:

Allows user to enable Smart Noise Reduction on either receiver channel or both. Settings are: Off, Normal and Full. The default setting for digital compatibility modes is “Off.” The default setting for hybrid modes is “Normal.”

Talkback:

Allows user to enable the Talkback (TB) function on either receiver channels or both, to determine where the TB outputs are routed, and to select how the TB signals interact with the normal program audio on those outputs. If “Off” is selected for a receiver channel, then no Talkback function will occur on that channel, even if the transmitter’s programmable switch is set to “TB” and activated. “Override” indicates that if a TB command comes from the transmitter, then the TB audio goes to the specified receiver output, and the normal audio from that channel is muted. “Mix” indicates that the TB audio and the standard audio routed to that receiver output will be mixed to that output. “TB Only” indicates that the normal audio routed to that output is muted, and only the TB audio will be present, and, only when the TB command is activated on the transmitter.

If AES3 output type is selected on one or both of the receiver outputs, it is possible to keep the normal audio on both channels separate from any TB audio. To do this, have normal audio on receiver channel 1 routed to AES1L, and the TB audio routed to AES1R. Meanwhile, receiver channel 2 audio can be routed to AES2L, and it’s TB audio can be routed to AES2R.

Polarity:

Allows user to set audio polarity of each channel as either positive or negative.

Compat Modes

Allows user to set compatibility mode per receiver channel. Available modes are: mono digital modes D2 and HDM (High Density Mode); stereo digital modes Duet channel 1, 2, or both and DCHX (encrypted) channel 1, 2, or both; and mono Hybrid modes: NA Hybrid, NU Hybrid, EU Hybrid, and JA Hybrid. EU and JA modes are not available for Block 941.

SD Card Settings

Files:

Allows user to access list of files saved on the microSD card in .WAV format. Using the **UP/DOWN** buttons to highlight a specific file, the pressing **MENU/SEL** displays file details including date, time, and length of the recording.

Takes:

Lists files on the microSDHC card in the Scenes and Takes format. Files are listed in the form of **SXX TXXX**. Selecting a file will display date, time, and length of recording.

Record:

Starts the DCR822 in recording mode, with files named

and Scenes and Takes sequenced according to the settings in SD Card>File Naming, and SD Card>Scene & Take. The number of tracks recorded depends on the Compat modes chosen on the receiver channels, and how many channels of audio are present on each. For instance, if both channels are in Hybrid compat modes (mono audio on each) then two tracks will be recorded in the .WAV file. If channel 1 is in D2 mode and channel 2 is in DCHX mode with “Both” selected (2 channels of audio) then there will be 3 tracks recorded in the .WAV file.

Scene & Take:

Allows user to set scene and take file naming starting point. Subsequent starts and stops of recordings will increment the take number.

Format Card:

Prompts user for confirmation of erasing files and preparing card for recording of audio files.

File Naming:

Allows users to set the naming format of file between:

- Sequence
- Clock Time
- Scene&Take

Load Group and Save Group:

Tuning groups allows lists of frequencies to be created, edited, stored and transferred in order to constrain tuning or allow for quick selection of frequencies shared between devices. Groups are created in the receiver, then can be shared to other receivers or transmitters via IR Sync, or by storing the group on a data-formatted microSDHC card and loading that card onto the target units. To load a pre-existing set of groups from a data-formatted microSDHC card, choose Load Group, then select the desired group file by pressing the **UP** or **DOWN** buttons, then press **MENU/SEL**. To save frequency groups that have been previously populated, choose Save Group, then press the **MENU/SEL** button. All groups will be saved as .GRP files.

About Card:

Shows the space left on the card, maximum recording time available on the card and the next file number in the naming sequence.

Recovering an Interrupted Recording

Recordings can be reliably recovered even if the microSDHC memory card is accidentally removed or the battery dies while a recording is in progress. If a recording is interrupted, all of the audio is present on the card and can be easily recovered by the DCR822. The DCR822 keeps track of the length of the most recent recording so it can supply a good suggestion for the length to recover. If the length is ever unknown or the DCR822’s suggestion seems incorrect, it is always possible to override the suggested length. If in doubt, specify the maximum length possible, in which case the entire remainder of the card is recovered. All of the interrupted recording will be present, followed by extra contents which might be random noise or audio from previously deleted recordings.

NOTE: Good batteries or an external power supply is required for the recovery. If recovery is attempted with weak batteries, a message will appear indicating that fresh batteries will be required.

Once fresh batteries have been installed, power on the DCR822 and insert the card with the interrupted recording. The DCR822 will detect the interrupted recording and display:



And then:

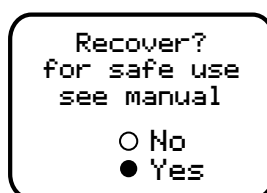

If “No” is chosen, nothing is done to the card and the DCR822 will not use the card. If “Yes” is chosen”, a prompt appears asking for the length of the recording to recover, specified as a number of hours and minutes. The default suggestion will be the approximate length of the most recent recording. It is always safe to recover a longer recording than was made. To specify the recovery time, use the **MENU/SEL** button to navigate and specify the hours and minutes fields.

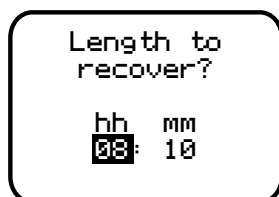

Once set as desired, use **MENU/SEL** to reveal the “GO” soft button and press the **DOWN** button to begin the recovery process. Recovery is nearly instantaneous. When completed, the display will show:



IR & Keys Menu

The operations below depend on the compatibility mode selected and the transmitter used. The DCR822 has two-way IR for use with digital products (DBu, DBSM, etc.) and one-way IR for use with older IR-capable units such as LT and HMa. One-way protocol can only “Send Frequency.”

NOTE: You must position the transmitter’s IR port directly in front of the DCR822 IR port, as closely as possible, to guarantee a successful sync.

Send Frequency

Sends operating frequency to the transmitter, each channel separately. Press the **UP** button to send the Channel 1 frequency, and the **DOWN** button to send the Channel 2 frequency. Success for digital compat modes is indicated on the receiver as “**IR Sync OK.**” For digital modes, failure will be indicated on the receiver as “**IR SYNC FAILED.**” For Hybrid compat modes, success will be indicated on the transmitter as “**IR SYNC.**” Failure will be indicated on the transmitter as “**CP Err**” or “**Block Mismatch**” depending on the transmitter model and the source of the error.

Send All

(available only for digital compat modes)

Sends frequency, channel name/s, and Talkback state to the transmitter. Press the **UP** button to send the information from Channel 1, and the **DOWN** button to send the information from Channel 2. Since two-way IR Sync is only available for digital transmitters, “N/A” will be next to any channels that are in a Hybrid compatibility mode.

Get Frequency

(available only for digital compat modes)

Send or retrieve (get) frequency from the transmitter. Choose encryption type by pressing the **UP** and **DOWN** buttons. Select **MENU/SEL** to get frequency.

Get All

(available only for digital compat modes)

Retrieve (get) transmitter’s frequency, Talkback state, and channel name. Press the **UP** button to get all and use for Channel 1. Press the **DOWN** button to get all and use for Channel 2. Since two-way IR Sync is only available for digital transmitters, “N/A” will be next to any channels that are in a Hybrid compatibility mode.

Group Sync

These functions allows you to send or get Tuning groups via IR sync to/from transmitters and receivers capable of

using Groups (DCR822, DCHR, DBSM, DBSMD, DPR, DPR-A). Use **MENU/SEL** button to navigate between the group choice and the send/get mode. With the group letter(s) highlighted, use the **UP** or **DOWN** buttons to select which frequency group (or all groups) to send or get. Then press the **MENU/SEL** button to select Send or Get. Use the **UP** or **DOWN** buttons to toggle between Send or Get. Then, press **MENU/SEL** again and “Go” will appear in the lower right corner. Press the **DOWN** button to complete the sync operation.

Encryption Key Management

The DCR822 has four options for encryption keys:

- **Universal:** This is the most convenient and basic option available, and the default setting on all Lectrosonics D2 digital units. All encryption-capable Lectrosonics transmitters and receivers contain the Universal key. The key does not have to be generated in the DCR822. Simply set the Lectrosonics encryption-capable transmitters and receivers to Universal key type, and the encryption is in place. This allows for convenient encryption amongst multiple transmitters and receivers, but is not as secure as creating a unique key.
- **Shared:** This key policy is designed for sports coverage and similar applications where a unique key provides enhanced security, but multiple transmitters and receivers can share the same key. Once generated by the receiver, the key can be transferred via IR to transmitters or additional receivers.
- **Standard:** This key policy provides excellent security, second only to the Volatile key policy. Once a unique key is created in the receiver, it can be transferred via IR only to transmitters, but not to other receivers. The receiver tracks the number of times the key is transferred. Once a Standard key has been transferred 256 times, an alert will indicate that a new key must be created.
- **Volatile** This is the most robust key policy available. After a unique key is created, it can be transferred only to transmitters, not other receivers. If a transmitter is powered off, it must have the key sent to it again from the receiver. If the receiver is powered off, a new key must be generated and sent to the transmitters. In encryption terms, this is the “one time use” key management policy.

Encryption Keys

The DCR822 generates high entropy encryption keys to sync with encryption-capable transmitters. The user must select a key type and create a key in the DCR822, and then sync the key with the transmitter.

1. Begin by selecting a **Key Type**.
IR&Keys --> Key Type --> Universal, Shared, Standard or Volatile.

2. Next, if using the Shared, Standard or Volatile key type, select **MAKE KEY** to generate a new key. Select “Yes” to confirm Make Key. IR&Keys --> Make Key.

NOTE: When Universal Key type is selected, there is no prompt to create key, as it is not necessary.

3. A message will indicate that an Encryption Key has been created.
4. Sync new key with transmitter (see **Send Key**). The transmitted audio will then be encrypted with the new key.

Send Key

Select **SEND KEY** to transfer the encryption key to any compatible transmitters or, in Shared key policy, additional receivers. Success will be indicated by the message “**Encryption Key Sent**” on the receiver display, and “**Encryption Key Received**” on the transmitter display. IR key transfer failure will be indicated by the message “**IR Sync Failed**” on the receiver display.

Settings Menu

Lock/Unlock

The user can lock or unlock the receiver. In Locked condition, the menus and settings can be browsed but not changed. Attempting to change a setting or power off the unit while in the locked condition causes the message “Settings Locked” to appear on the screen. The Lock/Unlock condition will persist through battery changes or external power being removed.

Backlight

Controls the display backlight timeout interval, following the last button push. Choose from always on, 30 seconds, or 5 seconds. **The backlight will automatically come on with low battery warnings.**

RX Power

This function allows you to power off one or both receiver channels when not in use, to save power in a portable DC-powered system. Press the **MENU/SEL** button to select Channel 1 or Channel 2. Use the **UP** and **DOWN** buttons to turn on or off the selected receiver.

RX Bat Type

Press the **UP** or **DOWN** buttons to select the battery type in use for the receiver: Alkaline or Lithium (recommended).

Tx Bat Type

Set the battery type for each transmitter channel. Note that for digital transmitters, the battery type is set in the transmitter and thus if the transmitter is not on, “no link” will show on that receiver channel. Use **MENU/SEL** to toggle between Channel 1 and Channel 2, and then

use the **UP** and **DOWN** buttons to change the battery type settings for those channels (depending on compat mode).

Tx Bat Timer

Set transmitter battery timer alerts for each channel. Choose to enable/disable alert, set time in hour and minutes and reset timer. Use **MENU/SEL** to set and move the cursor and the **UP** and **DOWN** buttons to change values. To re-set the timer for the selected channel, press the **MENU/SEL** and **UP** buttons together.

Tx Bat Icon

Choose between Bar, Volt or Time. Use **MENU/SEL** to select the channel and the **UP** and **DOWN** buttons to change values.

AutoOn

Press the **UP** or **DOWN** buttons to enable or disable the auto power on function.

Edit Names

Edit channel names to easily identify channels on the receiver home screens or identify different DCR822 receivers in a rack. Press **MENU/SEL** to move the cursor, and press the **UP** or **DOWN** buttons to change the numbers and letters at that cursor location. Press the **PWR/BACK** button to save your changes.

Date & Time

Allows setting of calendar date in Year, Month and Day, and time in 24 hour clock, with minutes and seconds. This information is then placed in the meta data header on any .WAV files recorded onto the microSD card.

Locale

The locale should be chosen based on the region where the receiver is being used. There are three options available:

- **NA:** (default setting) represents the North American locale and prevents operation in the Astronomical Band (from 608 to 614 MHz). It allows tuning from 470.100 up to 607.950 MHz.
- **EU:** represents the European locale, and has unrestricted operation over the entire band of the device: 470.100 up to 614.375 MHz.
- **AU:** represents the Australian locale, and has unrestricted operation over the entire band of the device: 470.100 up to 691.175 MHz.

Default

This setting restores the unit to factory settings.

About

Displays general information about the DCR822, including band, microcontroller and FPGA versions. The microcontroller version number is the first number under the band, followed by the FPGA version number after the forward slash.

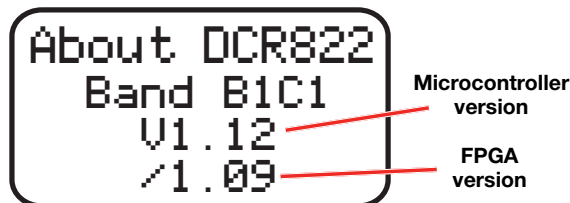

Antenna Mounting and Orientation

A variety of accessories are available to enable various antenna mounting options. For maximum operating range, the antennas should be vertical and above the camera and other equipment. The AMJ Rev. A antenna is jointed so the whips can be oriented vertically regardless of the orientation of the receiver.

Maximum sensitivity is perpendicular to the whip, so an ideal setup is shown in Fig. 1 and Fig. 2 where the receiver is mounted in either a vertical or horizontal position with the whips oriented vertically.

Fig. 3 depicts the receiver and antenna whips oriented horizontally, which places the null of the receiver antenna pattern pointing toward the transmitter. The result, of course, is a weak signal entering the receiver.

Fig. 4 depicts the worst setup where the nulls in both receiver and transmitter patterns face one another.

The transmitter antenna whips can point upward as shown in these diagrams, but they will work just as well with the whip pointing downward. Mount the transmitter so that the whip is vertical and not in direct contact with the wearer's body or metallic objects in clothing and costuming.

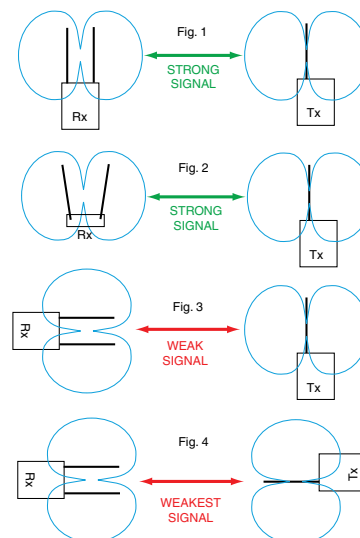

AMJ Jointed Antenna

The AMJ antenna is a general purpose design with a hinged joint that pivots in both directions for positioning the whip at any desired angle. The pivot allows the whips to be oriented vertically regardless of the mounting position of the receiver.



The hinged joint pivots in both directions

A “bendable” mounting strap is included that allows vertical orientation on a variety of surfaces. Several other adapters are also available for temporary or fixed installations.

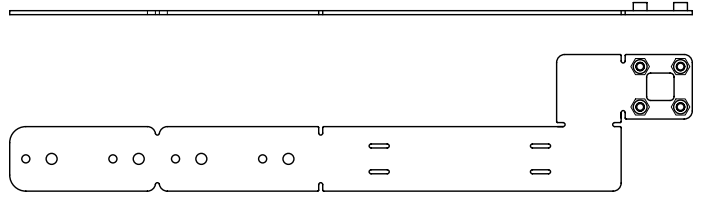

This is one example of using two splitters to feed two receivers.

SNA600A Omni Dipole Antenna

The SNA600a antenna is a versatile tool for use with wireless microphone receivers or IFB transmitters. The center frequency of its 100 MHz bandwidth is tunable from 550 to 800 MHz; however, the roll-off above and below this band is gradual. The SNA600a measures lower than a 2:1 SWR (Standing Wave Ratio) from 465 MHz to 850 MHz when the antenna arms are fully extended.

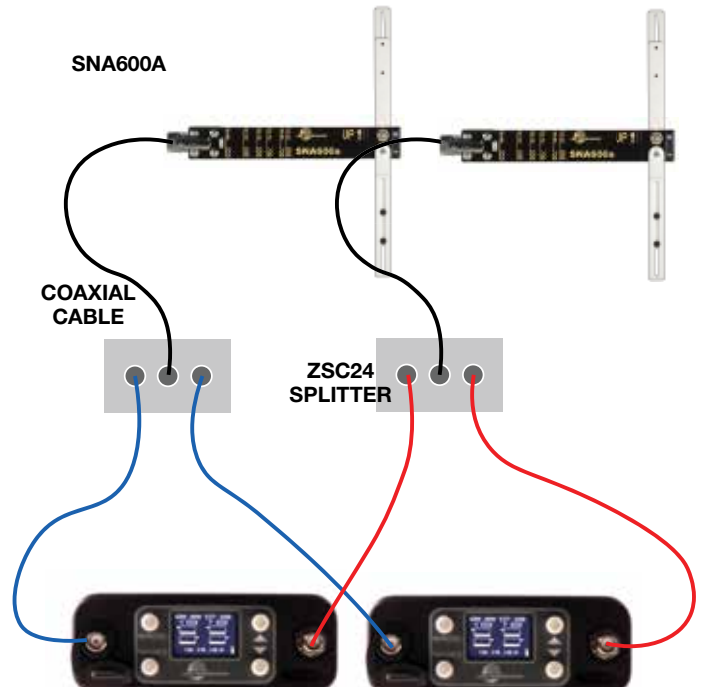
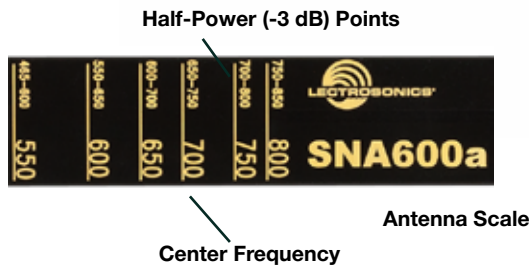
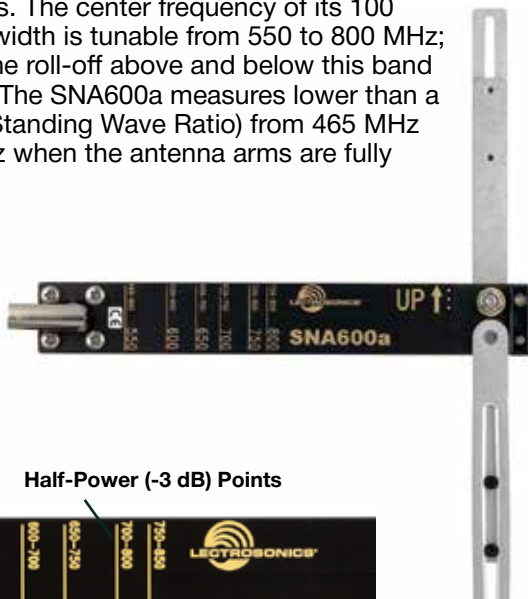

Use Lectrosonics P/N 21770 BNC (F) to SMA (M) adapter; Pomona P/N 4290

Antenna/Block Reference Table

The two AMJ whip antennas supplied with the receiver are factory cut to specific frequency blocks as shown in the table below. A colored cap and label are used on blocks 20 through 26, and a black cap and label are used on the other blocks to denote the frequency range of each model.

The chart is useful for fabricating an antenna from coaxial cable or other materials, or for identifying the frequency of an antenna that is not marked. The lengths shown are specifically for the AMJ whip antenna with a SMA connector, as determined by measurements with a network analyzer. The optimal length of the element in other designs will likely be different than those shown in this table, but since the bandwidth is typically wider than the specified block, the exact length is not critical for useful performance in whip, dipole and coaxial designs.



The hinged joint pivots in both directions



	BLOCK	FREQUENCY RANGE	CAP COLOR	ANTENNA WHIP LENGTH	
A1	470	470.100 - 495.600	Black w/ Label	5.47"	141.2 mm
	19	486.400 - 511.900	Black w/ Label	5.19"	133.9 mm
	20	512.000 - 537.500	Black w/ Label	4.95"	126.2 mm
B1	21	537.600 - 563.100	Brown	4.73"	119.6 mm
	22	563.200 - 588.700	Red	4.47"	113.8 mm
	23	588.800 - 614.300	Orange	4.23"	108.5 mm
C1	24	614.400 - 639.900	Yellow w/Label	4.07"	103.4 mm
	25	640.000 - 665.500	Green w/Label	3.87"	98.3 mm
	26	665.600 - 691.100	Blue w/Label	3.68"	93.5 mm
	941	941.525 - 959.825	Black w/Label	2.53"	64.3 mm
	961	961.100 - 1014.900	Use antenna for 941		

Note: Not all Lectrosonics products are built on all of the blocks covered in this chart.

CUTTING TEMPLATE

Lay uncut antenna on this template and cut to length for the desired frequency block

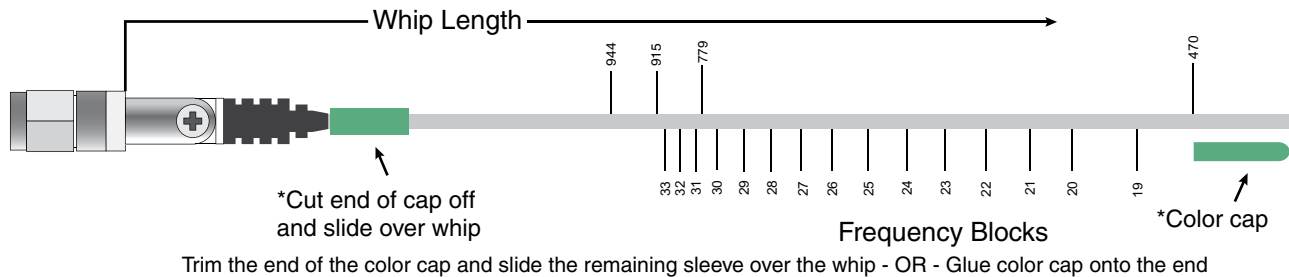

Note: Check the scale of your printout. This line should be 6.00 inches long (152.4 mm).

Installation and Operating Instructions

1. Install fresh batteries or connect an external power source to the DCR822 and attach the antennas. Power on the unit.
2. Unless frequency settings have been previously assigned, use SmartTune (p. 13) to select clear frequencies at your location.
3. Connect the audio cable to the Receiver Audio Out XLR jack.
4. Set the Power **ON/OFF** switch to **ON** and verify that the LCD panel activates.
5. Adjust the transmitter gain.

THIS IS PERHAPS THE MOST IMPORTANT STEP IN THE SET UP PROCEDURE. Refer to your transmitter manual's Operating Instructions section for details on how to adjust the transmitter gain. In general, adjust the transmitter gain so that the voice peaks will cause the audio modulation indicators on the receiver and transmitter to show full modulation on the loudest peak audio levels. Normal levels should cause the DCR822's audio level icon to fluctuate fully. This will result in the best possible signal to noise ratio for the system.

Important:

- Adjust the transmitter gain **before** you adjust the receiver output level.
- When the transmitter is fully modulated, its limiter will prevent any further increases in level.
- The receiver output circuitry is set to run at full output, and the level control is simply an attenuator. There is no difference in signal to noise ratio across the entire adjustment range of the receiver output level. The transmitter input gain is the critical adjustment that will affect the signal to noise ratio.
- Adjust the Audio Output type (analog or AES3 digital) according to the type of input on your equipment. Use the **LEVEL** menu and adjust the level with the **UP** and **DOWN** buttons.

The input levels of different cameras, mixer/recorders, and PA equipment vary, which may require that you adjust the **AUDIO OUT** to an intermediate position. Try different settings and listen to the results. If the output of the receiver is too high, you may hear distortion or a loss of the natural dynamics of the audio signal. If the output is too low, you may hear steady noise (hiss) along with the audio. The DCR822 audio output is designed to drive any audio input device from microphone level to +7dBu line level. If using AES3, the audio cannot be adjusted.

Note: The test tone output is especially useful for an exact level match. With the test tone running, adjust for the maximum desired peak level using the metering on the connected

Locking and Unlocking the DCR822 Front Panel Controls

The front panel controls can be "LOCKED" to prevent accidental changes being made during operation and handling.

To LOCK or UNLOCK the DCR822, choose **MENU/SEL**, then **SETTINGS**. Use the arrow buttons to toggle front panel controls. **LOCK/UNLOCK**, then choose **MENU/SEL** to save the setting.

Note: The unit cannot be powered off if LOCKED. Unlock first to power off.

Firmware Update

Firmware updates are made using a microSDHC memory card. Download and copy the following firmware update files to a drive on your computer.

- **DCR822_vX_XX.hex** is the microprocessor firmware update file, where “X_XX” is the revision number.
- **DCR822_fpga_vX_XX.mcs** is the FPGA firmware update file, where “X_XX” is the revision number.

Please check your existing version numbers and then update either or both files if there are newer versions available.

In the computer:

- 1) Perform a **Quick Format** of the card. On a Windows-based system, this will automatically format the card to the FAT32 format, which is the Windows standard. On a Mac, you may be given several options. If the card is already formatted in Windows (FAT32) - it will be greyed out - then you do not need to do anything. If the card is in another format, choose Windows (FAT32) and then click “Erase”. When the quick format on the computer is complete, close the dialogue box and open the file browser.
- 2) Copy the **DCR822_vX_xx.hex** and **DCR822_fpga_vx_xx.mcs** files to the memory card, then safely eject the card from the computer.

In the DCR822:

- 1) Leave the DCR822 turned off and insert the microSDHC memory card into the slot.
- 2) Hold down both the **UP** and **DOWN** arrow buttons on the receiver and turn the power on.
- 3) The device will boot up into the firmware update mode with the following options on the LCD:
 - **Update** - Displays a scrollable list of the program files on the card.
 - **Power Off** - Exits the update mode and turns the power off without updating.

NOTE: If the unit screen shows **FORMAT CARD?**, power the unit off and repeat step 2. You were not properly pressing UP, DOWN and Power at the same time.

- 4) Use the arrow buttons to select **Update**, then press the **MENU/SEL button**. Use the **UP** and **DOWN** arrow buttons to select the desired file and press **MENU/SEL** to install the firmware. The LCD will display status messages while the firmware is being updated.
- 5) When the update is complete, the LCD will display this message: **UPDATE SUCCESSFUL REMOVE CARD**. Remove the memory card or use the back button to return to the update page.

- 6) Once finished with updates, power the unit back on. Verify that the firmware version was updated by opening the Power Button Menu and navigating to the **About** item.
- 7) If you re-insert the update card and turn the power back on for normal use, the LCD will display a message prompting you to format the card:

Format Card? (files lost)

- **No**
- **Yes**

If you wish to record audio on the card, you must re-format it. Select **Yes** and press **MENU/SEL** to format the card. When the process is complete, the LCD will return to the Main Window and be ready for normal operation.

If you choose to keep the card as is, you may remove the card at this time.

The firmware update process is managed by a bootloader program - on very rare occasions, you might need to update the bootloader.

WARNING: Updating the bootloader can corrupt your unit if interrupted. Don't update the bootloader unless advised to do so by the factory.

- **DCR822_boot_vX_XX.hex** is the bootloader file

Follow the same process as with a firmware update and select the DCR822boot file.

NOTE: The ability to perform firmware updates via the USB port will be built into a future update. Check the Firmware Release Notes as updates are announced.

DCR822 and Wireless Designer

The DCR822 is now supported in the current version of Wireless Designer via USB connection. Be aware of the following when preparing to connect your DCR822 to Wireless Designer via USB:

The DCR822 must have the micro and FPGA firmware both updated to v1.30 or higher. Wireless Designer version must be at least 2.0.30 for macOS, or version 2.0.34 or higher for Windows. These are available on our Support website at: <https://www.lectrosonics.com/wireless-designer.html>.

Diagnostics

Multi-channel System Checkout

Interference can result from a wide variety of sources including TV station signals, other wireless equipment in use nearby, or from intermodulation within a multi-channel wireless system itself. Regardless of how the frequencies were coordinated, a final checkout procedure is always a good idea.

Scanning with the RF spectrum analyzer built into the DCR822 system will identify external RF signals, but it does not address the compatibility of the selected frequencies.

The pre-coordinated frequencies address in-system intermodulation, but obviously cannot take into account RF signals from external sources that may be present in the location where the system will be operating.

1. Set up the system for testing.

Place antennas in the position in which they will be used and connect to the receivers. Place transmitters about 3 to 5 feet apart, about 25 to 30 feet from the receiver antennas. If possible, have all other equipment on the set, stage or location turned on as well, especially any mixing or recording equipment that will be used with the wireless system.

2. Set all receivers on clear channels.

Turn on all receivers, but leave the transmitters off. Observe at the RF signal strength indicator for each receiver module. If a signal is present, change the frequency to a clear channel where no signal is indicated. If a completely clear channel cannot be found, select the frequency with the lowest RF level indication. Once all receiver modules are on clear channels, go to step 3.

3. Turn each transmitter on one at a time.

Start with all transmitters turned off. As you turn on each one, look at the matching receiver to verify a strong RF signal is received. Then, look at the other receivers and see if one of them is also picking up the signal. Only the matching receiver should indicate a signal. Change frequencies on either system slightly until all channels pass this test, then check again to see that all channels are still clear as done in step 2.

4. Turn each transmitter off one at a time.

With all transmitters and receivers turned on, turn each transmitter off one at a time, in turn, and look at the RF level indicator on the matching receiver module. The RF level should disappear or drop to a very low level. If it does not, change frequency on that receiver and transmitter and try it again. When a clear frequency is found, turn the transmitter on and move on to the next channel.

IMPORTANT: Any time a frequency is changed on any of the systems in use, you must start at the beginning and go through this procedure again for all systems. With a little practice, you will be able to do this quickly and save yourself some “multi-channel grief.”

Pilot Tone Bypass

Hybrid compatibility modes (NU Hyb, EU Hyb, etc.) use a supersonic “pilot tone” to control the squelch (audio mute) of a receiver module to keep it silent until a valid signal is received. When a signal with the correct pilot tone is received, the squelch opens and audio is delivered to the output. Pilot tone squelch control also eliminates transients (clicks and pops) when transmitters are turned on and off.

Pilot tone control can be bypassed as a diagnostic tool. Bypass opens the audio output of the receiver unconditionally, allowing you to listen to any signals entering the receiver to help identify their source. Pilot tone bypass will also allow you to use a transmitter that has a defective pilot tone circuit.

CAUTION: When pilot tone is bypassed and the transmitter is turned off, excessive noise will be present. Turn the audio level down before bypassing pilot tone.

Supplied Parts and Accessories

CCMINI

Padded zipper pouch for handheld transmitter



40073 Lithium Batteries

DCR822 is shipped with four (4) batteries. Brand may vary.



5510

Flash Memory Card, microSDHC memory card to SD Adapter Included. Brand and capacity may vary.



AMJ19 and AMJ22

Swivelling Whip Antenna with Standard SMA Connector, Available in Block 19 or 22.



AMJ25

Antenna with swiveling SMA connector. Shipped with B1C1 units only.



Optional Parts and Accessories

MCSRXL

Audio output cable, TA3F Plug to XLRM, 12 in.



P1371

Replacement micro SDHC slot dust cover; early version.



P1401

Nylon SD slot dust cover; later version.



21926

MicroB USB cable for firmware updates.



21770

Male SMA to Female BNC Adapter.



ACOAXTX

Antenna, Coaxial, SMA Plug for Transmitters, Specify Block.



SNA600A Omni Dipole Antenna

Versatile Antenna, 100 MHz Bandwidth tunable from 550 to 800 MHz. Includes mounting screws and bracket.



DCR12/A5U

Power Supply, 110-240 VAC In, 12VDC Regulated Out, 500mA. Includes international adapters.



BATTSLED

General Purpose Battery Adapter, Optional Spring Loaded Clip is Available, BATTERY NOT INCLUDED.



MC52

TA3F to TA3F Line Level Adapter Cable



PS2200A

Power Cable, 12 in., Hirose4 to Dual LZR



PS200A

Power Cable, 12 in., Hirose4 to LZR



Troubleshooting

Symptom

Possible Cause

INITIAL POWER ON

Display not active or lit.

External power supply disconnected or inadequate.
Main power supply fuse tripped. Turn the receiver off, remove the cause of the overload and turn the receiver back on.
Wrong polarity power source. The external DC in requires POSITIVE to be on the center pin.
Display has timed out. Press any button to revive.
Batteries exhausted.

ANTENNAS AND RF SIGNAL STRENGTH

RF Level is weak.

Receiver may need to be moved or reoriented.
Antenna on transmitter may be defective or poorly connected - double check antenna on transmitter.
Improper length of antenna, or wrong antenna on transmitter or receiver. UHF whip antennas are generally about 3 to 5 inches long. UHF helical antennas may be shorter, but are often less efficient.

No RF Signal

Make certain frequency settings on transmitter match the receiver frequency settings.
Check battery in transmitter.
Ensure transmitter is in transmit mode.

AUDIO SIGNAL QUALITY

Poor signal to noise ratio

Transmitter gain set too low.
The noise may not be in the wireless system. Turn the transmitter audio gain all the way down and see if the noise remains. If the noise remains, then turn the power off at the transmitter and see if it remains. If the noise is still present, then the problem is not in the transmitter.
If noise is still present when the transmitter is turned off, try lowering the audio output level on the DCR822 and see if the noise lowers correspondingly. If the noise remains, the problem is not in the receiver.
Receiver output is too low for the input of the device it is feeding. Try increasing the output level of the DCR822.

Distortion

Transmitter input gain too high. Check and/or readjust input gain on transmitter according to the LEDs on the transmitter and then verify the setting with the audio meter in the main window.
Audio output level too high for the device the DCR822 is feeding. Lower the output level of the DCR822.

Bad frequency response or generally poor audio quality.

Ensure the receiver is set to the compatibility mode that matches the transmitter in use.

Display Not Active or Lit

Ensure that the batteries are fresh and of good quality.

Specifications and Features

Receiver

Operating Frequencies (MHz):

Model A1/B1:	470.100 - 614.375
Model B1/C1:	537.600 - 691.175
941:	941.525 - 959.825
961:	961.100 - 1014.900

NOTE: It's the user's responsibility to select the approved frequencies for the region where the transmitter is operating.

Frequency Selection Steps:	25 kHz
Frequency Response:	25 Hz to 20 kHz (+0/-3 dB)
Frequency Stability:	±0.001 %
Front end bandwidth:	±5.5 MHz, @ -3 dB
Sensitivity:	20 dB Sinad: 0.9 uV(-108 dBm), A weighted 60 dB Quieting: 1.12 uV (-105 dBm), A weighted
AM rejection:	>60 dB, 2 uV to 1 Volt
Modulation acceptance:	85 kHz
Spurious rejection:	85 dB
Third order intercept:	+15 dBm
Diversity method:	Vector Diversity (advanced true diversity)

Antenna inputs:	Dual SMA female jacks; 50 Ohm impedance
Audio output:	Rear panel 2 TA3M connectors; can drive 600 Ohm, adjustable from -50 to +7 dBu in 1 dB steps (into nominal 10 k bal. load)

Audio Performance (overall system):

THD: 0.2% (typical)

SNR at receiver output (dB):

	SmartNR	No Limiting	w/Limiting
Note: The dual envelope "soft" limiter provides exceptionally good handling of transients using variable attack and release time constants. Once activated, the limiter compresses 30+ dB of transmitter input range into 4.5 dB of receiver output range, thus reducing the measured figure for SNR without limiting by 4.5 dB	OFF	103.5	108.0
	NORMAL	107.0	111.5
	FULL	108.5	113.0

Input Dynamic Range:	125 dB (with full Tx limiting)
Overall Latency (time delay):	1.4 ms with digital source, <2.9 sm with Hybrid TX
Audio Test Tone:	1 KHz, -50 to +7 dBu, <1%THD

Controls:

Front Panel:	<ul style="list-style-type: none"> • LCD display • Menu/Sel, Pwr/Back, Up/Down Arrow Buttons • SD Card Reader • IR Port
--------------	---

Rear Panel:	<ul style="list-style-type: none"> • Analog/AES audio output jack (2) • External DC input • Battery compartment • USB port
-------------	--

External Power: Minimum 9 Volts to maximum 17 VDC
2.5 W; 170 mA at 12 VDC

Battery Life: 6 hrs. continuous, w/ 4 disposable, 1.5VDC Lithium AA batteries (recommended)

Weight: 408 grams with batteries (14.4 oz.)

Dimensions: 3.23" wide x 1.23" high x 5.50" deep
82 wide x 31 high x 140 deep mm

Recorder

Storage media:	microSDHC memory card
File format:	.wav files (BWF)
A/D converter:	24-bit
Sampling rate:	48 kHz
Recording modes/Bit rate:	24 bit - 144 kbytes/s per channel (up to 4)

Audio Performance:

Frequency response:	25Hz to 20 kHz; +0/-3 dB
Dynamic range:	110 dB (A), before limiting
Distortion:	< 0.035%

Operating temperature range:

Celsius:	-20 to 50
Fahrenheit:	-5 to 122

Specifications subject to change without notice.

Available Recording Time

Using a microSDHC memory card, the approximate recording times are as follows. The actual time may vary slightly from the values listed in the tables.

Card Size	1 Track Hrs:Min	2 Tracks Hrs:Min	3 Tracks Hrs:Min	4 Tracks Hrs:Min
8 GB	15.30	7.45	5.10	3.53
16 GB	31.00	15.30	10.20	7.45
32 GB	62.00	31.00	20.40	15.30

FCC Notice

NOTE: This equipment has been tested and found to comply with the limits for a Class B digital device, pursuant to part 15 of the FCC Rules. These limits are designed to provide reasonable protection against harmful interference in a residential installation. This equipment generates, uses and can radiate radio frequency energy and, if not installed and used in accordance with the instructions, may cause harmful interference to radio communications. However, there is no guarantee that interference will not occur in a particular installation. If this equipment does cause harmful interference to radio or television reception, which can be determined by turning the equipment off and on, the user is encouraged to try to correct the interference by one or more of the following measures:

- Reorient or relocate the receiving antenna.
- Increase the separation between the equipment and receiver.
- Connect the equipment into an outlet on a circuit different from that to which the receiver is connected.
- Consult the dealer or an experienced radio/TV technician for help.

Changes or modifications to this equipment not expressly approved by Lectrosonics, Inc. could void the user's authority to operate it.



Service and Repair

If your system malfunctions, you should attempt to correct or isolate the trouble before concluding that the equipment needs repair. Make sure you have followed the setup procedure and operating instructions. Check the interconnecting cables and then go through the **Troubleshooting** section in this manual.

We strongly recommend that you **do not** try to repair the equipment yourself and **do not** have the local repair shop attempt anything other than the simplest repair. If the repair is more complicated than a broken wire or loose connection, send the unit to the factory for repair and service. Don't attempt to adjust any controls inside the units. Once set at the factory, the various controls and trimmers do not drift with age or vibration and never require readjustment. **There are no adjustments inside that will make a malfunctioning unit start working.**

LECTROSONICS' Service Department is equipped and staffed to quickly repair your equipment. In warranty repairs are made at no charge in accordance with the terms of the warranty. Out-of-warranty repairs are charged at a modest flat rate plus parts and shipping. Since it takes almost as much time and effort to determine what is wrong as it does to make the repair, there is a charge for an exact quotation. We will be happy to quote approximate charges by phone for out-of-warranty repairs.

Returning Units for Repair

For timely service, please follow the steps below:

- A.** DO NOT return equipment to the factory for repair without first contacting us by email or by phone. We need to know the nature of the problem, the model number and the serial number of the equipment. We also need a phone number where you can be reached 8 A.M. to 4 P.M. (U.S. Mountain Standard Time).
- B.** After receiving your request, we will issue you a return authorization number (R.A.). This number will help speed your repair through our receiving and repair departments. The return authorization number must be clearly shown on the **outside** of the shipping container.
- C.** Pack the equipment carefully and ship to us, shipping costs prepaid. If necessary, we can provide you with the proper packing materials. UPS is usually the best way to ship the units. Heavy units should be "double-boxed" for safe transport.
- D.** We also strongly recommend that you insure the equipment, since we cannot be responsible for loss of or damage to equipment that you ship. Of course, we insure the equipment when we ship it back to you.

Lectrosonics USA:

Mailing address:

Lectrosonics, Inc.
PO Box 15900
Rio Rancho, NM 87174
USA

Shipping address:

Lectrosonics, Inc.
581 Laser Rd.
Rio Rancho, NM 87124
USA

Telephone:

(505) 892-4501
(800) 821-1121 Toll-free
(505) 892-6243 Fax

Web:

www.lectrosonics.com

E-mail:

sales@lectrosonics.com

Lectrosonics Canada:

Mailing Address:

720 Spadina Avenue,
Suite 600
Toronto, Ontario M5S 2T9

Telephone:

(416) 596-2202
(877) 753-2876 Toll-free
(877-7LECTRO)
(416) 596-6648 Fax

E-mail:

Sales: colinb@lectrosonics.com
Service: joeb@lectrosonics.com

Self-Help Options for Non-Urgent Concerns

Our Facebook groups and weblists are a wealth of knowledge for user questions and information. Refer to:

Lectrosonics General Facebook Group: <https://www.facebook.com/groups/69511015699>

D Squared, Venue 2 and Wireless Designer Group: <https://www.facebook.com/groups/104052953321109>

The Wire Lists: <https://lectrosonics.com/the-wire-lists.html>

LIMITED ONE YEAR WARRANTY

The equipment is warranted for one year from date of purchase against defects in materials or workmanship provided it was purchased from an authorized dealer. This warranty does not cover equipment which has been abused or damaged by careless handling or shipping. This warranty does not apply to used or demonstrator equipment.

Should any defect develop, Lectrosonics, Inc. will, at our option, repair or replace any defective parts without charge for either parts or labor. If Lectrosonics, Inc. cannot correct the defect in your equipment, it will be replaced at no charge with a similar new item. Lectrosonics, Inc. will pay for the cost of returning your equipment to you.

This warranty applies only to items returned to Lectrosonics, Inc. or an authorized dealer, shipping costs prepaid, within one year from the date of purchase.

This Limited Warranty is governed by the laws of the State of New Mexico. It states the entire liability of Lectrosonics Inc. and the entire remedy of the purchaser for any breach of warranty as outlined above. **NEITHER LECTROSONICS, INC. NOR ANYONE INVOLVED IN THE PRODUCTION OR DELIVERY OF THE EQUIPMENT SHALL BE LIABLE FOR ANY INDIRECT, SPECIAL, PUNITIVE, CONSEQUENTIAL, OR INCIDENTAL DAMAGES ARISING OUT OF THE USE OR INABILITY TO USE THIS EQUIPMENT EVEN IF LECTROSONICS, INC. HAS BEEN ADVISED OF THE POSSIBILITY OF SUCH DAMAGES. IN NO EVENT SHALL THE LIABILITY OF LECTROSONICS, INC. EXCEED THE PURCHASE PRICE OF ANY DEFECTIVE EQUIPMENT.**

This warranty gives you specific legal rights. You may have additional legal rights which vary from state to state.

