

Desono™ DX Surface Mount Loudspeakers

Installation & Operation Guide

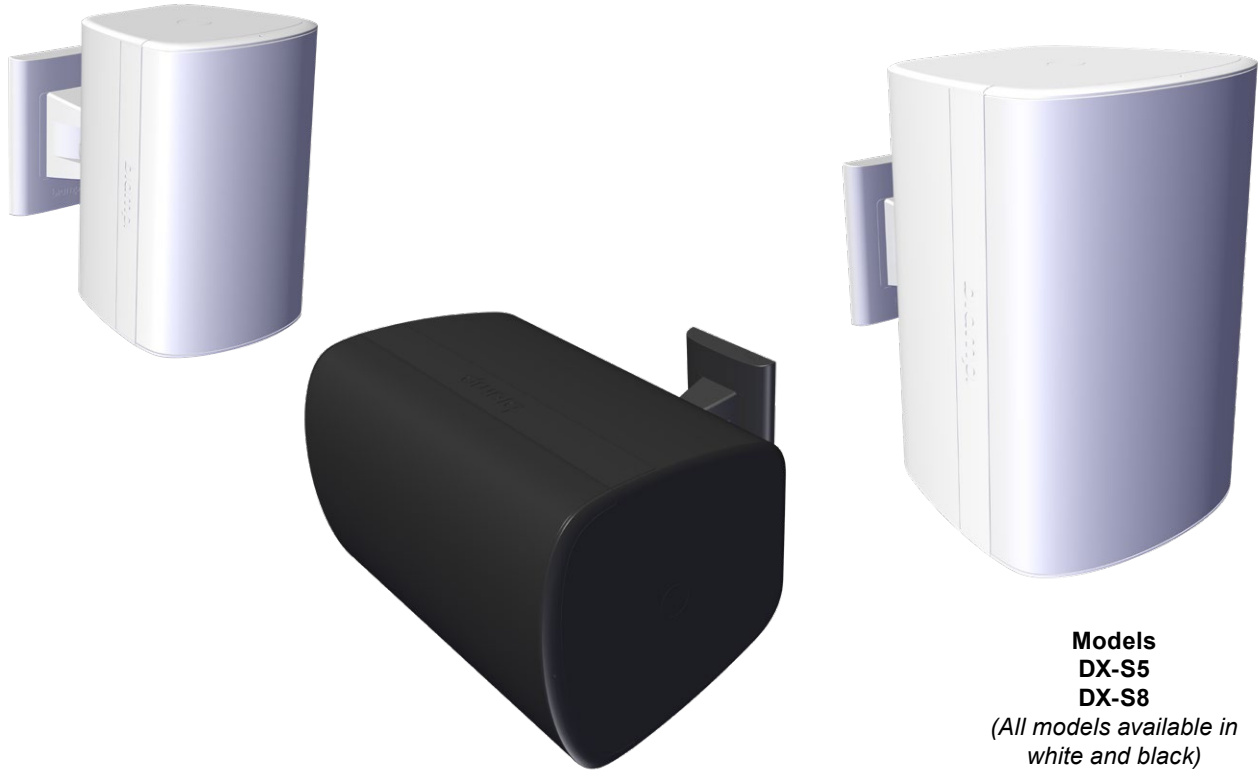

Models
DX-S5
DX-S8
(All models available in white and black)

PRODUCT DESCRIPTION

The Desono™ DX product family includes two two-way full-range surface-mount loudspeaker designs. They deliver excellent musicality and high intelligibility with deep extended bass response and wide, conical coverage patterns.

The loudspeakers are designed to be used in both indoor and outdoor environments and share attractive modern aesthetic styling. The loudspeakers can be mounted with our innovative ClickMount™ pan-tilt system that provides indexed aiming control. A ClickMount U-Bracket accessory also is available for low profile mounting to a structure.

CONTENTS

- Loudspeaker (DX-S5 or DX-S8)
- ClickMount pan-tilt bracket with cover plate
- Drilling template for bracket with mounting information



PRODUCT REPRESENTATION

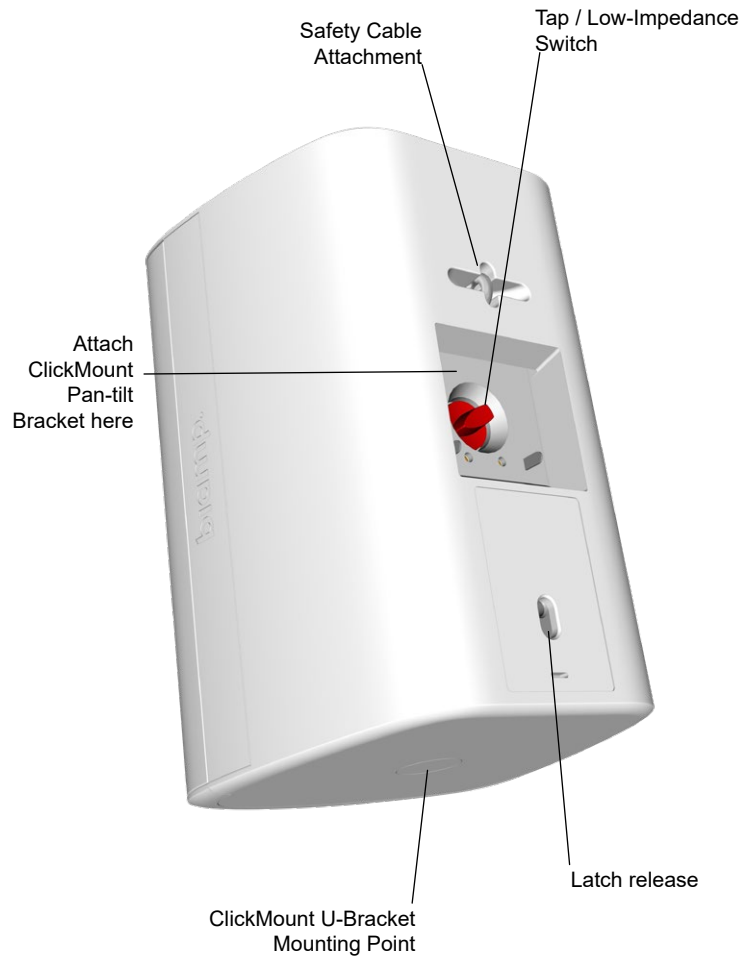
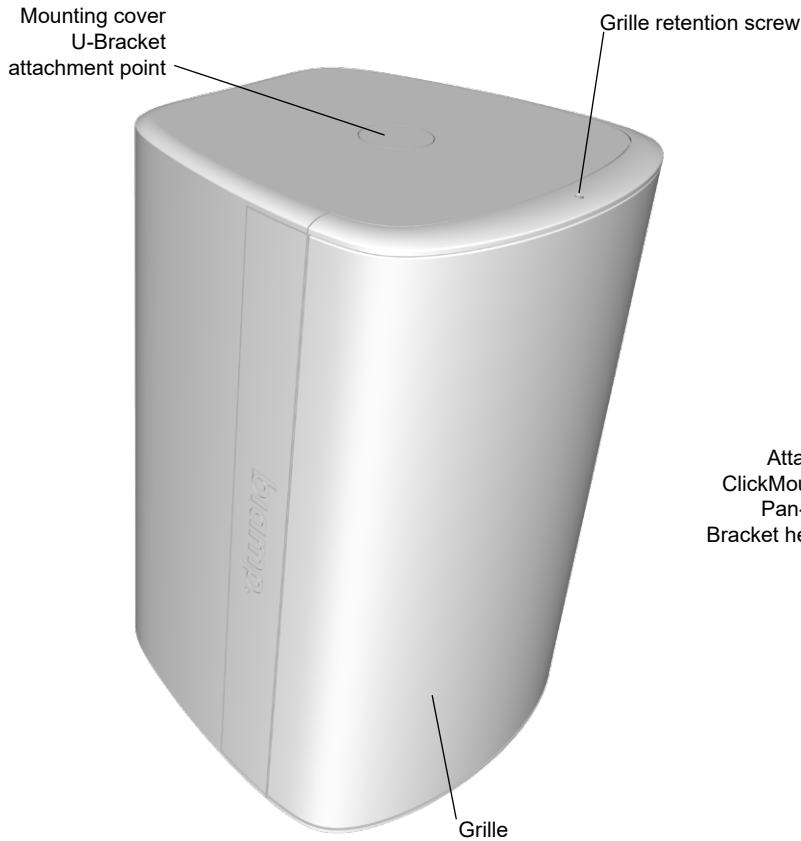

DX-S5 Model shown

Tools Needed

- Hex wrenches: 5mm, 5.5mm (or 7/32")
- Small flat screwdriver

RIGGING AND ELECTRICAL SAFETY



IMPORTANT: The loudspeakers described in this manual are designed and intended to be mounted to differing building surfaces using a variety of rigging hardware, means and methods. Installation of loudspeakers should only be performed by trained and qualified personnel. All electrical connections must conform to applicable city, county, state, and national (NEC) electrical codes.



DANGER: It is possible to experience severe electrical shock from a power amplifier. Always make sure that all power amplifiers are in the "OFF" position and unplugged from an AC Mains supply before performing electrical work.



IMPORTANT: Refer to the sections on installation and connections later in this manual for additional information on rigging and electrical safety.



IMPORTANT: When installing loudspeakers outdoors, use a support system with enough wind-load strength to comply with applicable codes and standards.



IMPORTANT: Please review the safety guide accompanying this product and these installation instructions prior to installing this loudspeaker.



CAUTION: Installation of Biamp loudspeakers should only be performed by trained and qualified personnel. It is strongly recommended that a licensed and certified professional structural engineer approve the mounting. Severe injury and/or loss of life may occur if this product is improperly installed.



DANGER: It is advised that a safety cable be secured to a suitable load-bearing point separate from the primary loudspeaker mounting point, with as little slack as possible so as not to develop undue kinetic force if the primary mount were to fail.

INSTALLATION

The loudspeaker can be mounted to a variety of surfaces but must be mounted to structural load bearing surfaces or substrates (not electrical gang boxes). There are two mounting options provided for the Desono DX family of loudspeakers: a standard ClickMount pan-tilt bracket and an U-Bracket accessory with a weather-resistant ClickPlug wiring insert. Wiring can be run to the mounting locations for each of the mounting options. When installing DX models outdoors, do not aim them upwards. Doing so will void the warranty and reduce the life of the loudspeaker.

Install the ClickMount Pan-tilt Bracket

The mounting points on the ClickMount bracket backplate are centered on the top, bottom and sides to accommodate direct mounting to wall studs and/or structural cross-members. They are sized to accommodate bolts up to 6 mm (1/4"), in order to provide a high safety factor when mounted. The bracket must be oriented with the arrow pointing UP.

1. Route the wire through the channel in the wall bracket and out the hole in the base (Figure 1), and attach the wall plate to the mounting surface (attachment hardware is not included). There is a small level in the backplate to ensure the bracket is straight. *Do NOT install the cover plate yet* - wait until the loudspeaker is ready for installation. Pull enough wire through so that the bracket arm can be fully tilted or panned.
2. Strip the insulation 0.5" (13mm) from the end of each wire. Lift a lever up and insert the wire fully into the tool-less wiring terminal (polarity is noted above the terminals). Press the lever back down on the wire to secure the connection. (Figure 2) Ensure the lever is fully snapped down and each wire is tight and can't be pulled out. Stranded wire should be twisted or crimp-on wire ferrules used to ensure all strands are captured.

NOTE: The levers are stiff - take care when lifting or pressing them down.

IMPORTANT: If the wall surface is to be finished after the brackets are installed, mask off the bracket and especially the ClickMount arm and wiring terminals to prevent any paint or dust from getting into the aiming mechanism or interfering with the wiring connectivity. Use low-adhesive painter's tape.

3. Once the wall is finished, the cover plate can be installed. Remove either knockout if needed for the wiring. Rotate the cover over the bracket arm and snap into place (Figure 3). A small screwdriver inserted in the center bottom edge of the plate depressing that tab will allow removal.

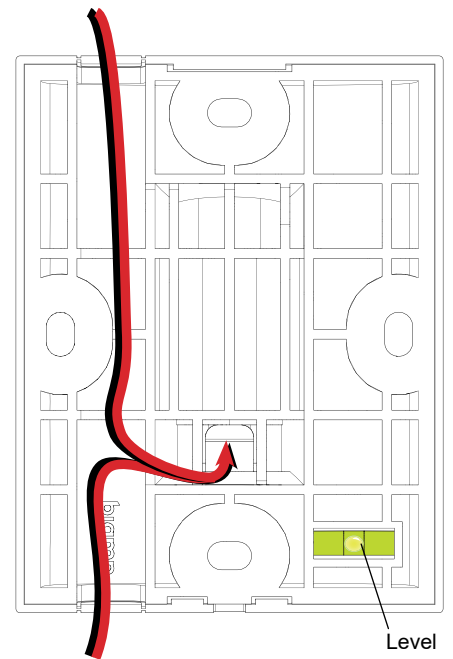

Figure 1. Wire routes through the rear of the ClickMount Pan-tilt Bracket

Lever-actuated (tool-less) wiring terminals will accommodate up to a 6 mm² (10 ga) conductor.

The bracket will accept up to 8 mm (0.3") diameter cable. The opening to the pan-tilt mechanism is 8 x 12 mm (0.3" x 0.47").



Figure 2. Wire path to wire the ClickMount bracket (single wire shown)

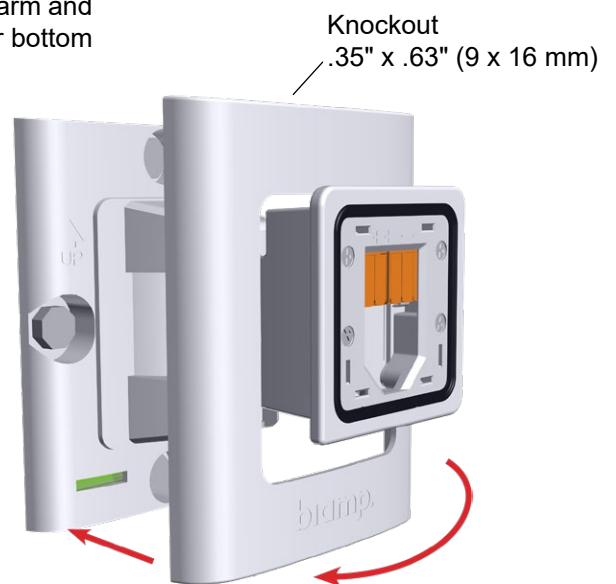

Figure 3. Before loudspeaker is attached fit the cover plate on the bracket and press into place

Installation - ClickMount Pan-tilt Bracket (continued)

Adjust the Tap Switch

- The tap switch should be adjusted before you attach the speaker to the bracket. Rotate the switch to the desired setting (Figure 4).

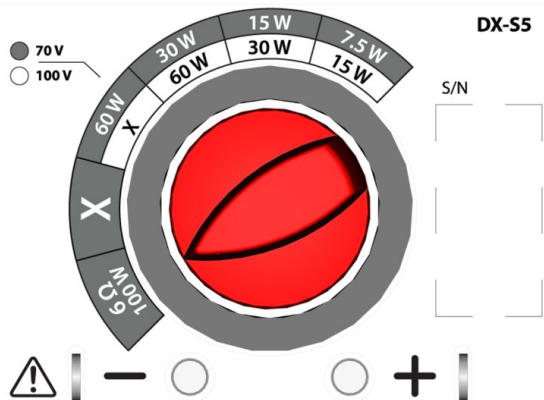

Figure 4. Rotate tap switch

Attach the loudspeaker to the bracket

NOTES: If you know the desired aiming angle of the loudspeaker, the ClickMount bracket can be adjusted before attaching the loudspeaker. Refer to aiming instructions on the next page.

- Mount the loudspeaker to the bracket by clicking the loudspeaker onto the ClickMount pan-tilt bracket. The latch should be in the up/locked position to start. Fit the edge of the bracket into the side of the speaker's receptacle opposite the latch. Then, swiftly rotate the speaker onto the bracket until the latch clicks in the up position. Check that the loudspeaker is fully installed by gently trying to remove it from the bracket. If the latch isn't fully engaged or moves, remove the speaker and reinstall. The loudspeaker may be installed in vertical or horizontal orientation. See Aiming Angle information on pages 7-8.
NOTE: It will not install upside down in a vertical orientation.

WARNING: Fully support the loudspeaker until it is clicked in place and latched securely. The weight of the loudspeaker will pull the ClickMount arm down and the loudspeaker may fall if it isn't latched on the ClickMount.

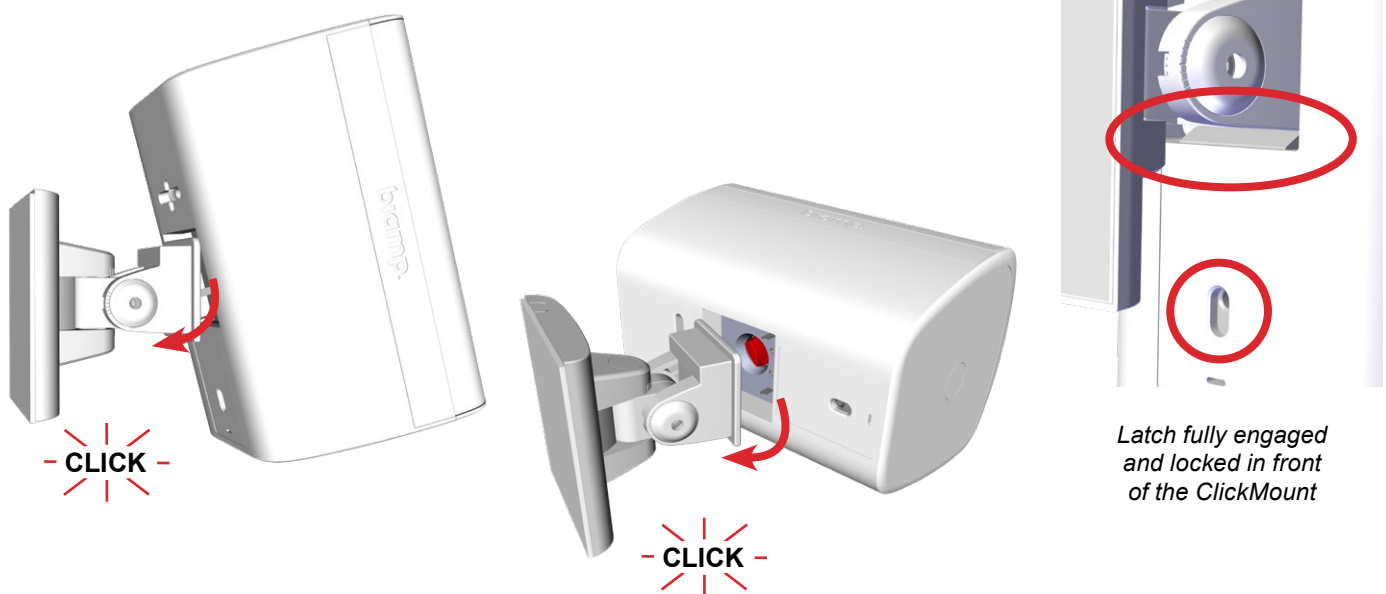

Figure 5. Rotate and press the loudspeakers on the ClickMount bracket

Installation - ClickMount Pan-tilt Bracket (continued)

- Secure the loudspeaker with a safety cable attached to the loop on the rear. The cable should be mounted to a secondary mounting point close to the bracket to avoid any kinetic force if the wall mount should fail, or the latch be released without the loudspeaker being supported. The cable should be a little slack to accommodate the aiming angle.

NOTE: The installer is responsible for sourcing the proper safety cable to meet all applicable local building codes and standards.

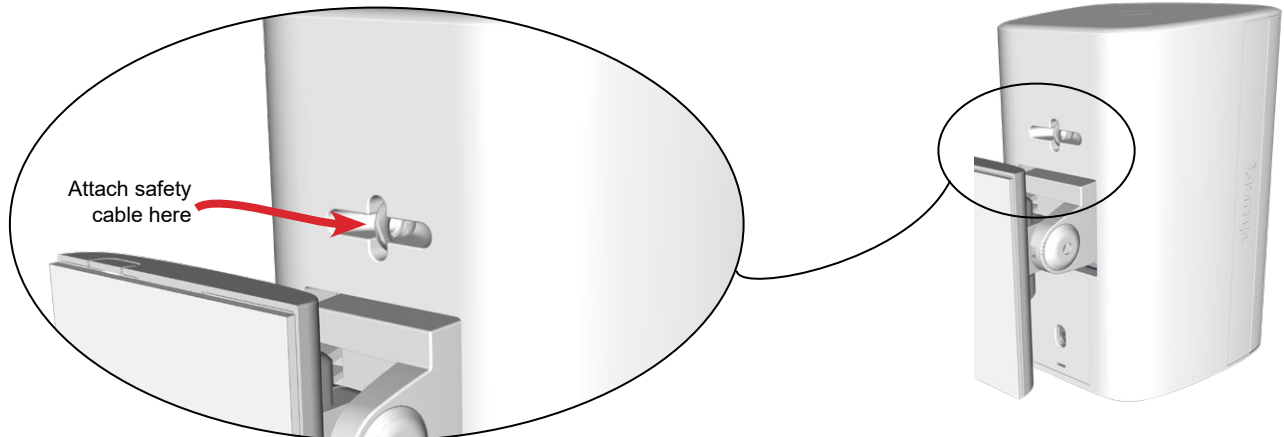

Figure 6. Attach safety cable

Aim the loudspeaker

- Insert a 5mm hex wrench into the bracket as shown (Figure 7) and loosen. The adjustment mechanism can be accessed from either side of the bracket.

IMPORTANT: Support the loudspeaker while manipulating the bracket's pan and tilt, because the weight of the loudspeaker will pull it down.

- As the bracket is loosened, it will first move horizontally (pan) and then vertically (tilt) as it is fully loosened. The bracket will move in indexed predetermined angles (see illustrations on the next page for aiming angle definitions). Fully loosen the bracket, tilt it to reach the desired vertical angle, tighten the bracket slightly and pan it to set the horizontal angle.

NOTE: Rotating the wrench $\sim 180^\circ$ will loosen the bracket for the pan, another 180° turn will loosen to adjust the tilt.

- Fully tighten the bracket with the hex wrench from the same side that it was loosened. After the bracket is tightened about a quarter turn will secure it. Do **not** overtighten.

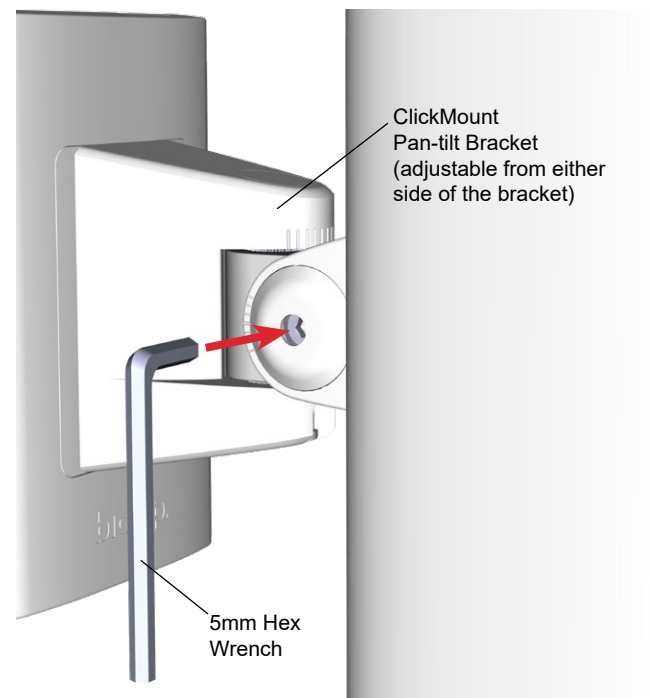

Figure 7. Insert and turn the hex wrench to loosen or tighten the bracket to adjust the aiming angle

Installation - ClickMount Pan-tilt Bracket (continued)

To remove loudspeaker from the bracket

The loudspeaker can be removed from the ClickMount pan-tilt bracket as follows:

1. Insert a 5mm hex wrench into the hole within the slot in the middle of the label on the rear panel (Figure 8a).
2. Pull down (or toward the base) and the latch will release and remain in the "unlocked" position until the speaker is removed from the bracket. The loudspeaker must be fully supported as you release the latch. See Warning at right.
3. Rotate the bottom of the speaker away from the ClickMount Bracket (Figure 8b).

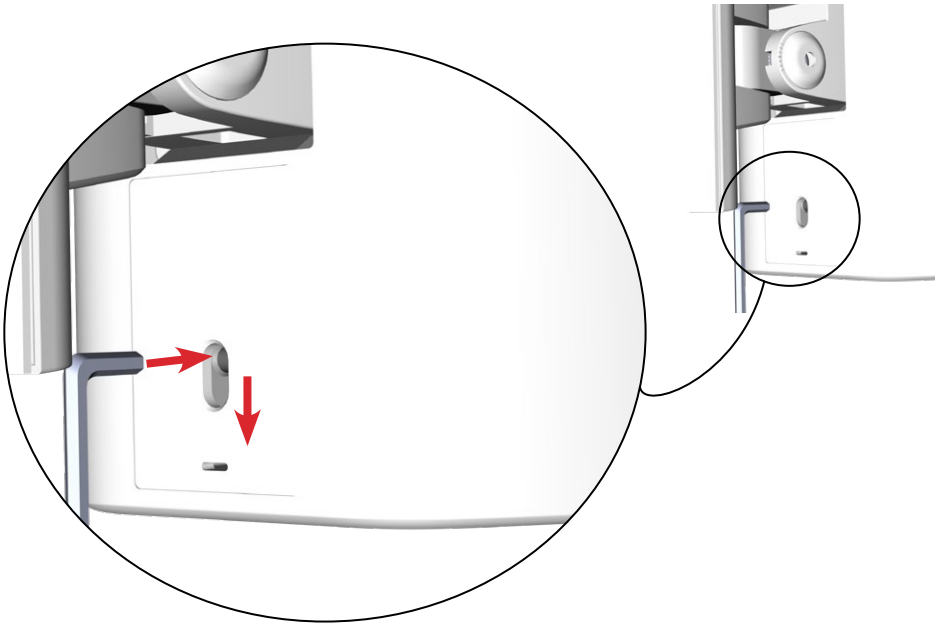

Figure 8a. Insert the hex wrench into the hole and pull down to release the latch

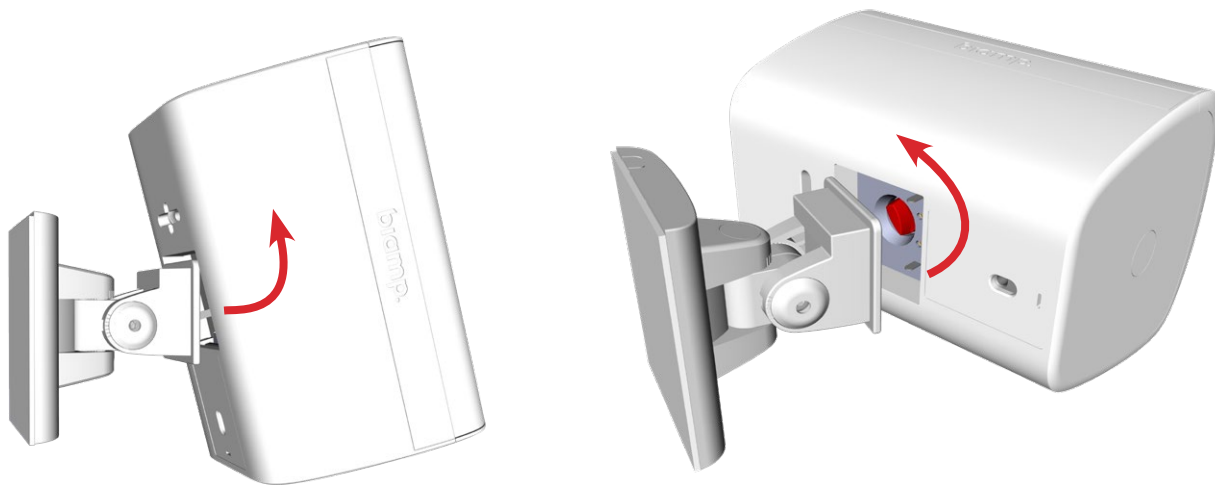
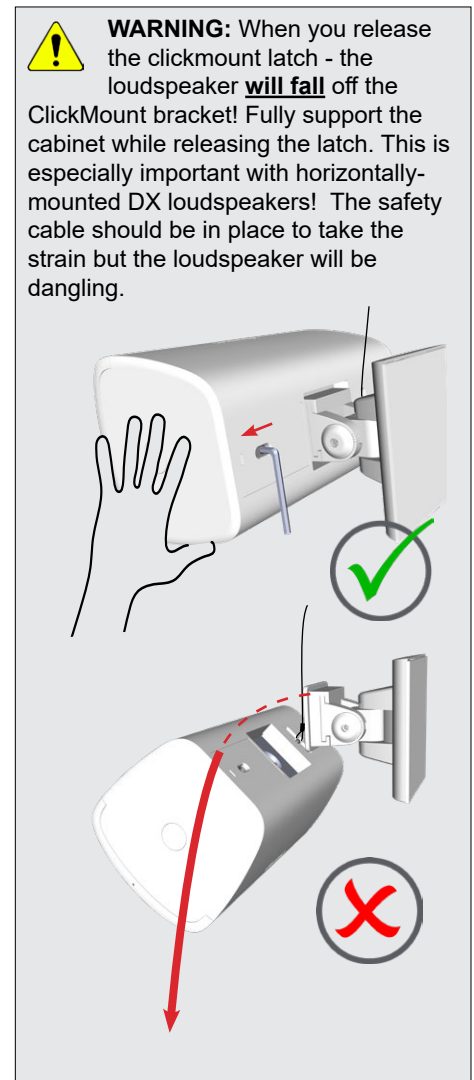

Figure 8b. Lift and rotate the bottom of speaker away from the ClickMount bracket.

ClickMount Pan-tilt Aiming Angles (DX-S5)



Portrait [Vertical] Orientation

Top View

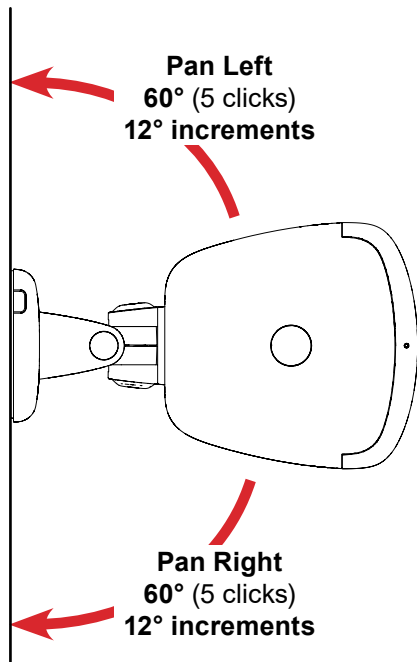

Side View

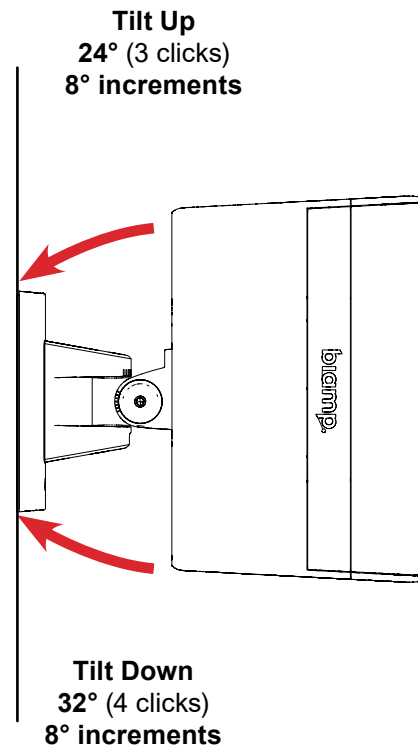

Landscape [Horizontal] Orientation

Top View

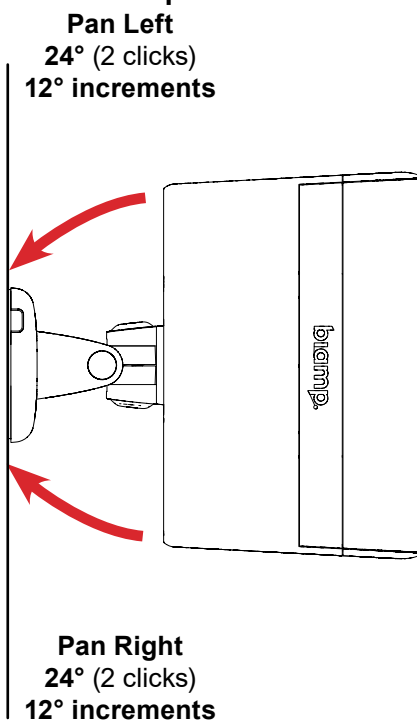

Side View

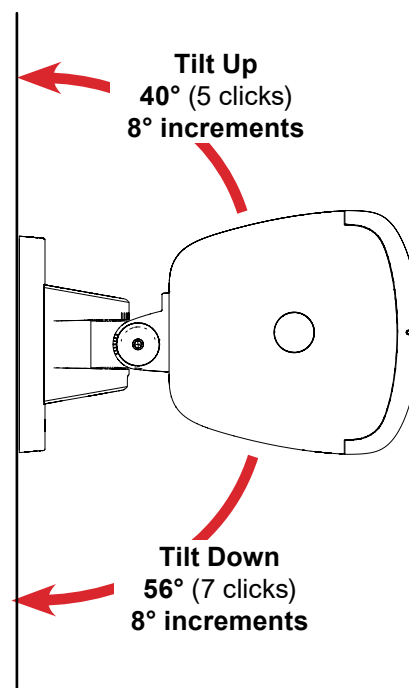

ClickMount Pan-tilt Aiming angles (DX-S8)



Portrait [Vertical] Orientation

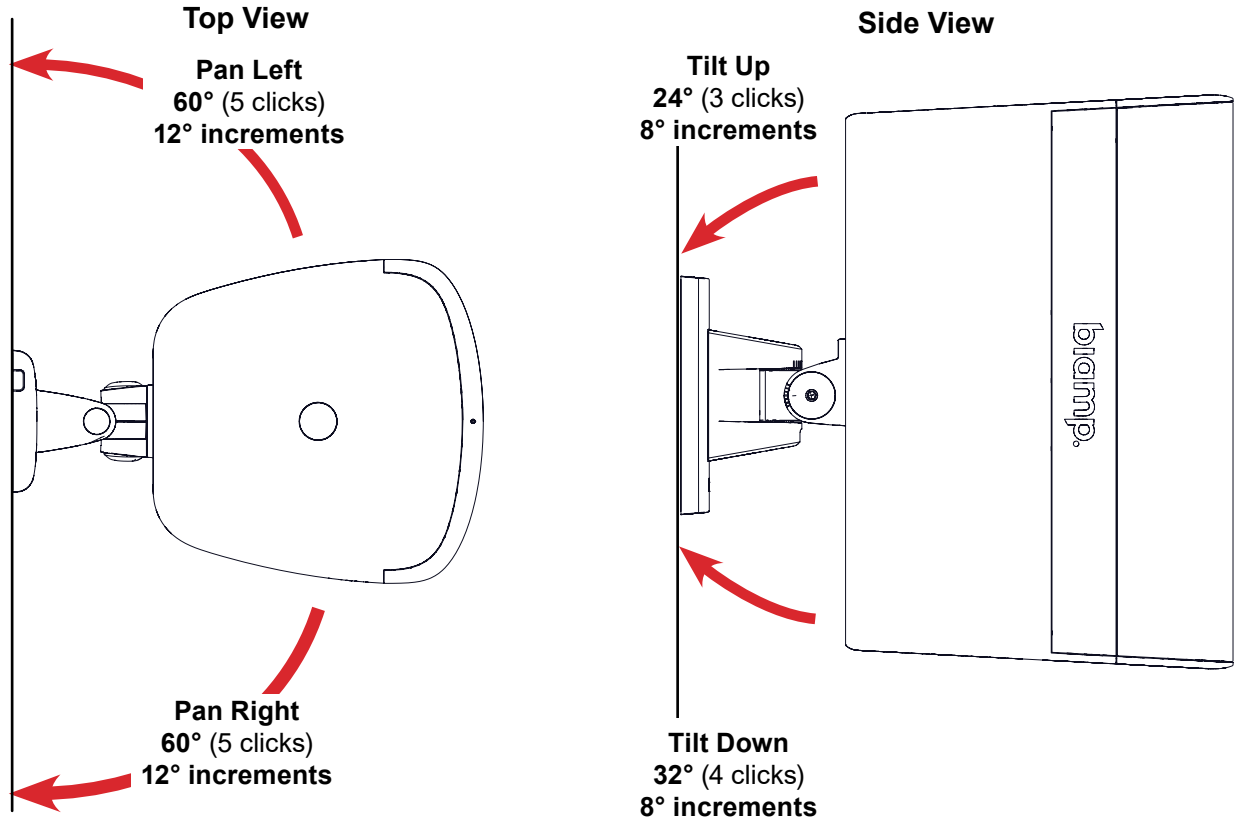

Landscape [Horizontal] Orientation

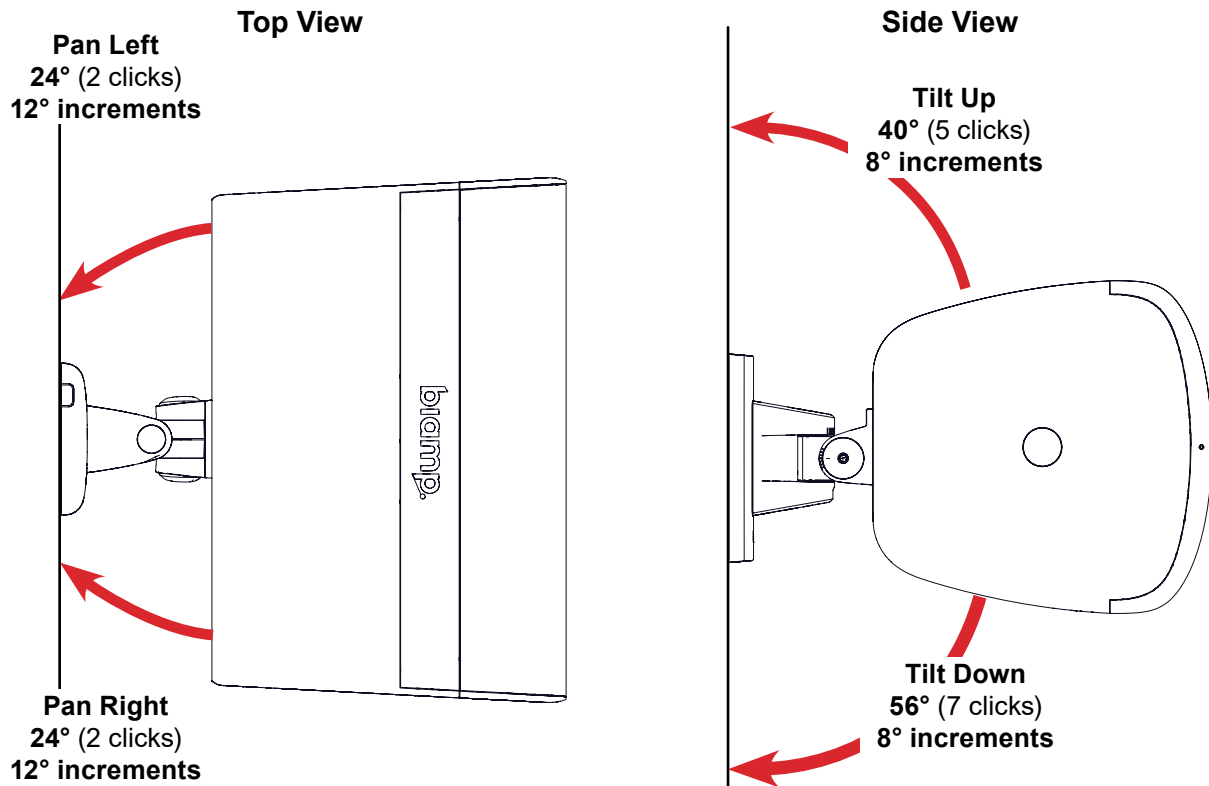

Installation - U-Bracket Accessory (SPA-UBDX200 -B/-W)

The U-Bracket is a low profile powder-coated Marine Grade aluminum design that allows the unit to be connected to a center suspension post or against the wall, ceiling, or other flat surface. It can also be mounted to a variety of third party stand and pole adapters.

1. Mount the U-Bracket prior to loudspeaker installation - the wiring can be routed along the channel and out any of the interior holes not used for mounting hardware. If mounting it horizontally on a wall, the slots should face up - see image below.
2. Sufficient cable should be pulled through the bracket holes to create a drip loop (damp/wet applications) with enough extra to connect to the ClickPlug. If the wall is not finished before the loudspeaker is mounted, the U-Bracket and cable should be masked with painter's tape or other masking material.

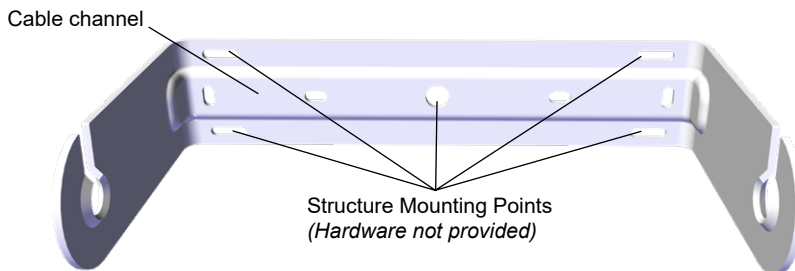
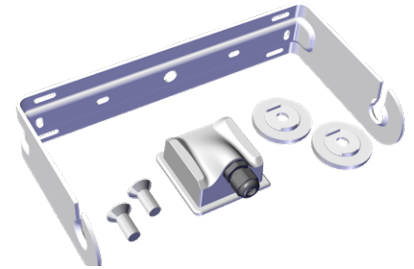

Cable / Wire Size

ClickPlug Cable gland nut will accept a 4-8mm (0.15-.3 in) diameter cable or 2 pairs 1.5mm² (16 ga) or 1 pair 2.5mm² (14 ga). For outside or moisture-rich environments - round SJOW cable or equivalent is advised to provide a weather-resistant seal in the tightened gland nut. Forming the cable into a drip loop will also prevent any moisture migrating into the gland nut.

Tools Needed

- 5.5mm (or 7/32") Hex wrench

3. Wire the ClickPlug as shown (Figures 9a, 9b) leaving enough for the likely mounting angle and a drip loop if necessary. Do this before mounting the loudspeaker.

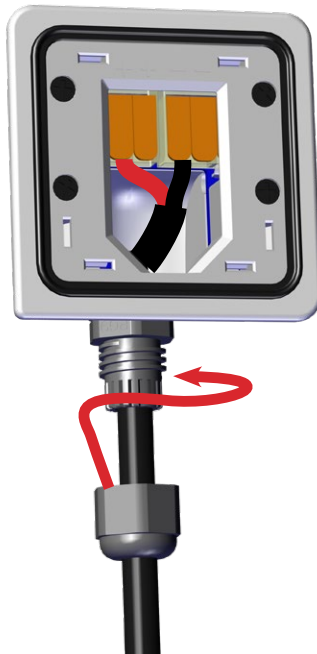

Figure 9a. Thread cable through the gland nut and barrel into ClickPlug
(2 conductor cable shown)

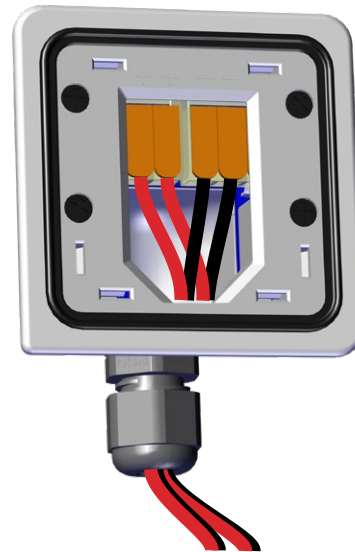

Figure 9b. ClickPlug wired with 2 pairs for daisy-chained applications

Installation - U-Bracket Accessory (continued)

Attach the Loudspeaker to the U-Bracket

4. The round caps covering the center mounting holes must be removed. Insert a thin blade into either the front or rear of each end cap and pry up. Pinch the side supports, and remove the caps. They can be discarded.
5. Insert a silicone spacer into the recess. The thicker edge should be toward the rear of the loudspeaker, and the tabs should fit into the recess slots.
6. Partially thread a flat head bolt into the center hole, leaving about 1/4" (6mm) of thread exposed. Repeat to install the spacer and bolt on the opposite end.
7. Slide the loudspeaker onto the U-Bracket with the bolts fitting in the slots. It will be easier if the back of the loudspeaker is facing the bracket.
8. Rotate to the approximate aiming position and tighten the bolts to hold the unit in place, but still allow it to rotate slightly.
9. Set aiming angle (2) and tighten the bolts (3) to prevent any movement. Once the angle is final, fully tighten bolts by using a 5.5mm (7/32") hex wrench. The loudspeaker will rotate 200° on the bracket.

IMPORTANT: The cabinet is finished with a light coat of paint. Take care to avoid scratching or marring the finish when sliding the loudspeaker onto the U-Bracket.

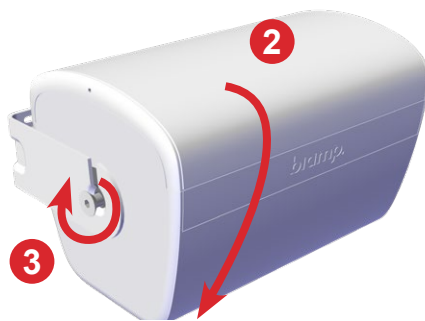
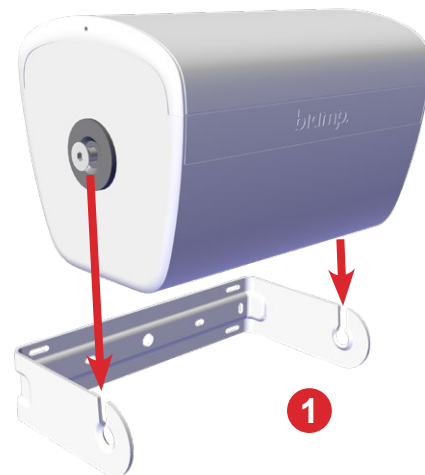
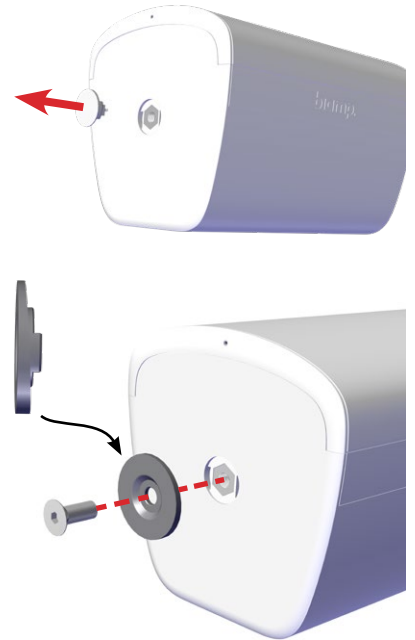

Figure 10. Mount the loudspeaker on the U-Bracket, rotate and secure angle
(Vertical and horizontal orientations shown)

Installation - U-Bracket (continued)

Adjust the Tap Switch

10. Rotate the tap switch knob to the desired setting before you attach the ClickPlug to the loudspeaker. (Figure 11).

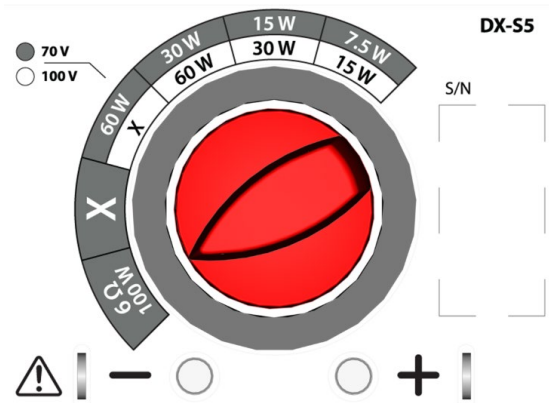

Figure 11. Rotate tap switch

Attach the ClickPlug

11. Insert the wired ClickPlug into the opening with the plug top (or side) into the indent under the safety cable loop first, then "click" it into place by pushing it against the latch (Figure 12) until it is fully seated, and the latch returns to the "up" position. The general orientation of the ClickPlug should be with the gland nut pointed down (exception noted on the next page). It cannot be mounted with the gland nut pointed toward the safety loop. **IMPORTANT:** The fit is very tight; press on the raised portion of the ClickPlug rather than the gland nut when inserting it.



CAUTION: The ClickPlug fit is very tight and is difficult to remove, especially if it is oriented toward the side of the unit. Avoid attaching the ClickPlug until the speaker is fully installed. If the unit is installed outdoors or in a damp location make sure a cable drip loop is utilized to prevent any moisture from migrating into the gland nut.



Figure 12. Attach ClickPlug

Installation - U-Bracket (continued)

The ClickPlug should be oriented as shown below. It can not be installed upside-down (Figure 13).

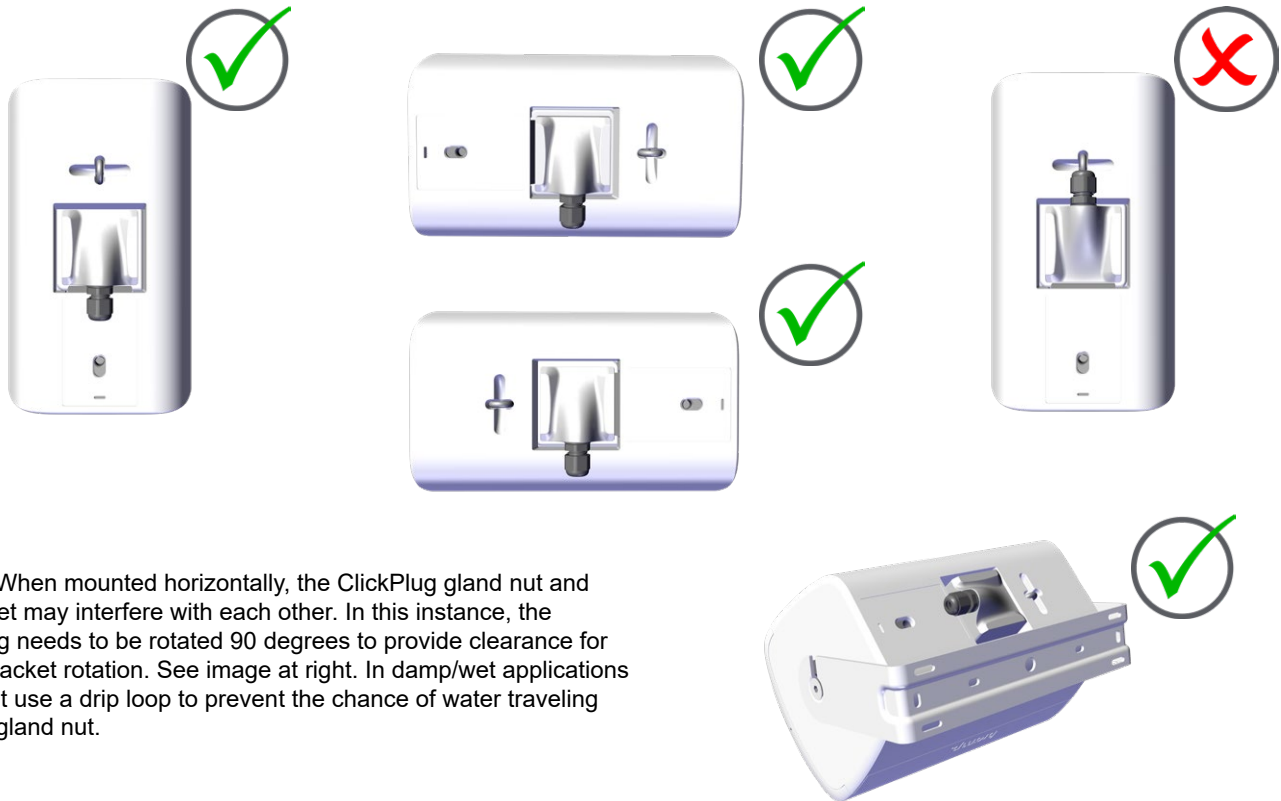

NOTE: When mounted horizontally, the ClickPlug gland nut and U-Bracket may interfere with each other. In this instance, the ClickPlug needs to be rotated 90 degrees to provide clearance for the U-Bracket rotation. See image at right. In damp/wet applications you must use a drip loop to prevent the chance of water traveling into the gland nut.

Figure 13. ClickPlug orientation

Attach Safety Cable

12. Secure the loudspeaker with a safety cable attached to the loop on the rear (Figure 14). The cable should be mounted to a secondary structural mounting point close to the U-Bracket to avoid any kinetic force if the mount should fail.

NOTE: The installer is responsible for sourcing the proper safety cable to meet all applicable local building codes and standards.

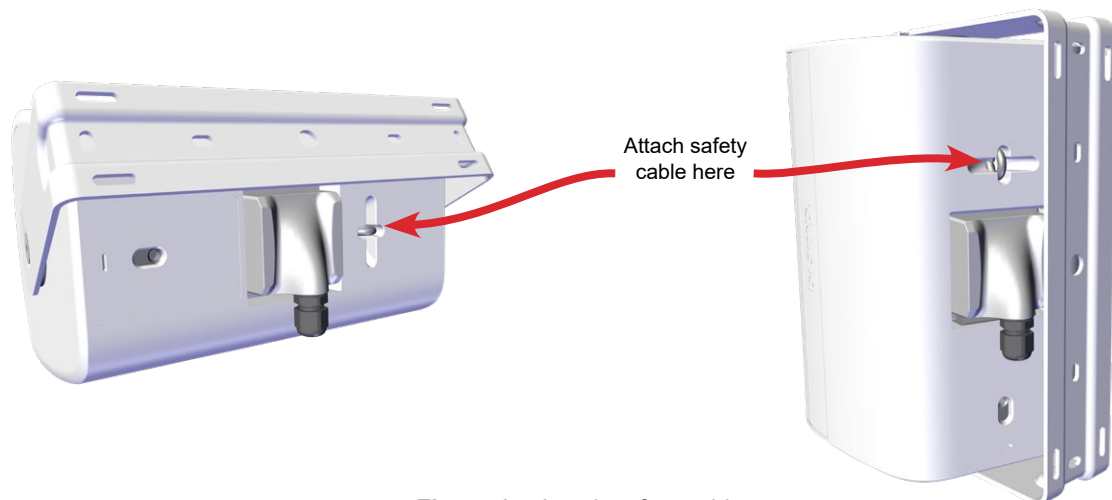

Figure 14. Attach safety cable

Remove ClickPlug from the Loudspeaker

The ClickPlug can be removed from the loudspeaker as follows:

1. Insert a 5mm hex wrench into the hole within the slot in the middle of the label on the rear panel (Figure 15a).
2. Pull down (or toward the base) and the latch will release and remain in the "unlocked" position until the ClickPlug is removed. If the loudspeaker is mounted close to a surface you can loosen the end bolts and rotate the speaker to access the ClickPlug. Take care to note the original position so it can be restored once the ClickPlug is back in place. See Caution at right.
3. The ClickPlug must be pulled away from the latch side first (Figure 15b). Do **NOT** use a tool to remove it as you will mar and/or deform the plastic.



CAUTION: The ClickPlug fit is very tight and is difficult to remove, especially if it is oriented toward the side of the unit. Avoid attaching the ClickPlug until the speaker is fully installed. If the unit is installed outdoors or in a damp location make sure a cable drip loop is utilized to prevent any moisture from migrating into the gland nut.

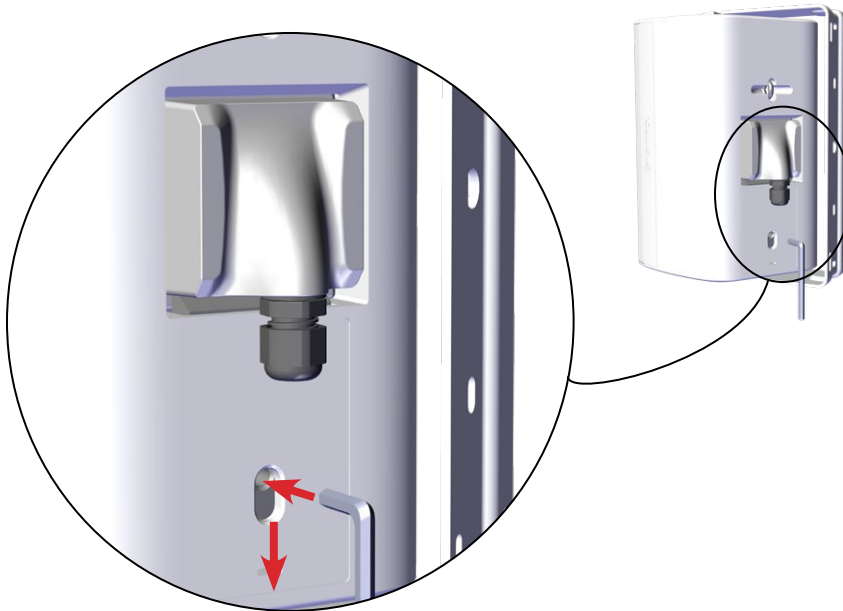

Figure 15a. Insert the hex wrench into hole and pull down to release latch

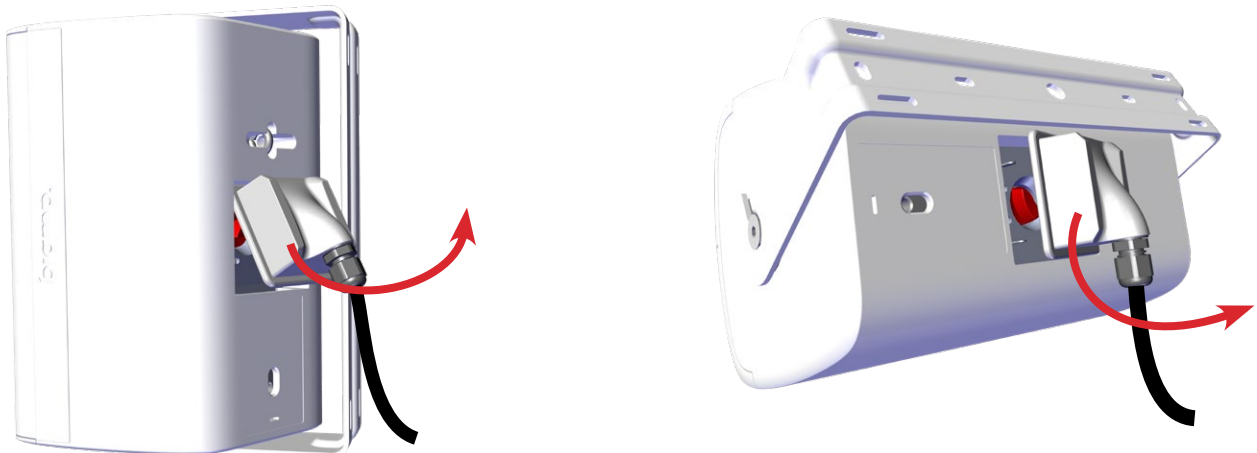

Figure 15b. Pull the ClickPlug away from the latch side. Do **NOT** use a tool to remove it as you will mar and/or deform the plastic.

PAINTING INSTRUCTIONS

The Desono DX cabinets have a light paint coat over the plastic material. They accept almost any type of latex or enamel (oil based) paint. We recommend application of two light coats. If the grille is to be painted, it must be removed to be painted (spray paint only) and then reinstalled.

IMPORTANT: Do not remove the scrim/foam material from the grille.

Process

If the grille will not be painted, fully mask it and proceed to Step 2.

1. Carefully remove the screws at the top and bottom of the cabinet. Pull the grille away from the cabinet. Take care not to bend the tabs or the grille (Figure 16).

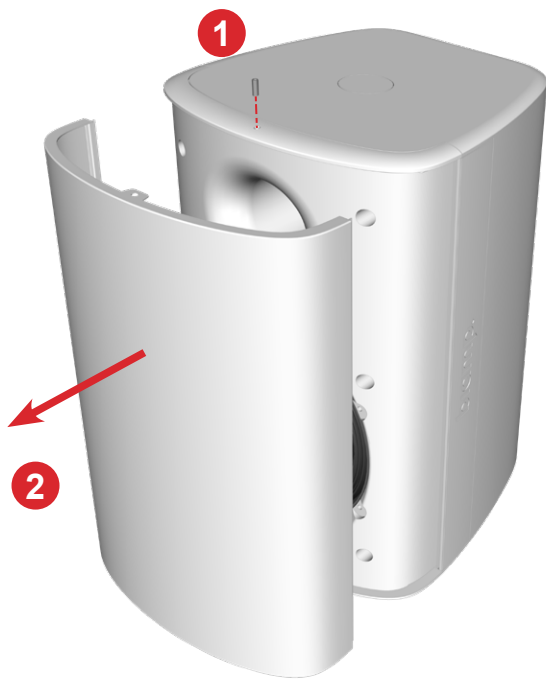

Figure 16. After removing the screws, carefully pry off the grille



CAUTION: NEVER use abrasives, gasoline, kerosene, acetone, methyl ethyl ketone (MEK), paint thinner, harsh detergents or other chemicals on the loudspeaker. These chemicals and agents may permanently damage the finish. Some are also toxic and highly flammable.

IMPORTANT: Take care not to bend or damage the grille on removal or reinstallation.

IMPORTANT: Blocking the grille holes with paint or getting any paint on the drivers or internal parts will affect loudspeaker performance and void the warranty.

IMPORTANT: For applications where UL1480A certification is required, ensure that relevant information on the rear label is not painted over.

You will need:

- Removable masking tape or painter's tape
- Machinist scribe tool or knife
- 1.5 mm hex wrench

Useful Tips

Use a sharp knife to trim the masking material close to the edges of the masked areas.

Painting Instructions (continued)

Loudspeaker preparation

2. Fully mask the full loudspeaker face so that all internal components will not receive any paint. Also mask off the rear input panel (area around the tap switch), the retaining latch for the mounts, the rear label, and latch access (Figure 17). We advise against using conventional masking tape and NEVER use duct tape: these kinds of tape generally leave adhesive residue that can be difficult to remove and that may actually cause damage. Painter's or other low-adhesive tape is best.
3. Clean the grille assembly and the loudspeaker cabinet by rubbing them with a lightly dampened cloth. Do not use abrasives such as sandpaper or steel wool.
4. After cleaning, apply two or more thin coats of either latex or oil-based paints. Latex paint will adhere better if an oil-based primer is used first. Paint is best applied by spraying it on, but the enclosure may be brushed with light coats.
5. To paint the grille, spray paint with 2 very light coats – increasing the distance from the spray can to the grille enough to cover grille but NOT clog any of the holes. You can blow air through the back of the grille to ensure that there are no paint particulates on the grille cloth. Let all components dry completely before reassembly.
6. Remove all of the masking materials and reassemble. **IMPORTANT:** The grille must be reinserted as carefully as it was removed - insert the sides into the cabinet with the top and bottom tabs fitting in the channel in the cabinet face. Do not push on the center of the grille as it may deform or not seat properly and adversely affect performance. Re-secure the grille with the screws in the top and bottom of the loudspeaker (Figure 18).

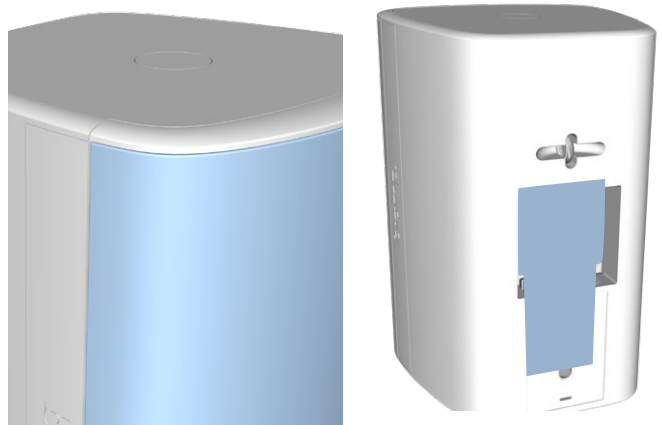
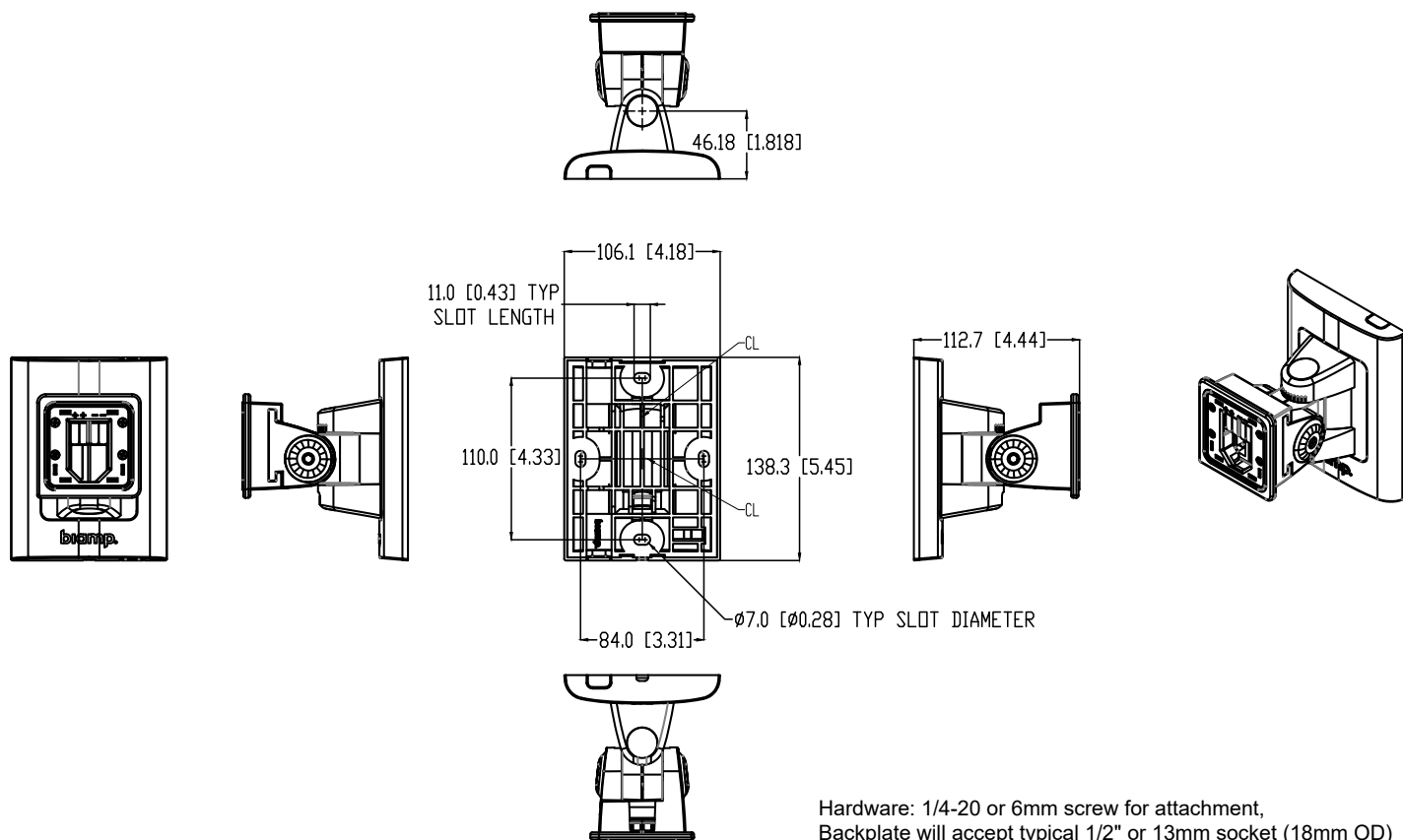

Figure 17. Mask off the full face, all connection points, input panel, rear label, and latch access



Figure 18. Reassemble the loudspeaker, carefully insert grille tabs and sides into the cabinet then re-install screws.

TECHNICAL DRAWING - CLICKMOUNT PAN-TILT BRACKET



CONTACT US

Email: support@biamp.com

Web: support.biamp.com

Warranty: biamp.com/legal/warranty-information

Safety & Compliance: biamp.com/compliance



A: 9300 S.W. Gemini Drive Beaverton, OR 97008 USA

W: www.biamp.com

02MAY2023