



PROTEUS BRUTUS



DATA SHEET



KEY FEATURES

- High Efficiency 1200W 6,500K Peak Field LED Engine
- Up to 75.000 Total Lumen Fixture Output
- CMY Color Mixing and Variable CTO
- 6 Position Color Wheel, High CRI, UV filter
- Complete FX System featuring Rotating Gobos, Animation, Iris, Frost
- Optional Full Blackout Framing Module
- Wide Zoom Range from 4.5° to 45° / Large 220mm (8.7") Front Aperture
- FIL (Foam In Lay) Polyurethane Foam Packaging Included

The **PROTEUS BRUTUS™** an extremely bright IP65 rated LED Wash FX fixture offering high intensity wash and effects qualities in any environment.

Providing up to 75.000 lumens from its custom designed 1200W Peak Field LED engine the **Proteus Brutus** is the ideal fixture for any outdoor application requiring superior output, bright and powerful wash, quiet operation as well as stunning colors and effects. **Proteus Brutus** provides the designer a comprehensive FX package with 6 rotating glass gobos, animation wheel, frost and a high-speed Iris. Its optional indexable framing system provides full blackout shutter cuts for precise beam shape control.

With a fast zoom range from 4.5° to 45° and an impressive 220mm front lens the **Proteus Brutus** has the power to cut through at great distances in any outdoor concert, special events and with its fully dust and waterproof design it is an ideal fixture for theme parks and cruise ships or any application that benefits from its sealed IP65 housing.

The **PROTEUS BRUTUS** fixture ships in a cardboard box with a custom fitted polyurethane foam FIL (Foam In Lay) insert. This foam insert easily fits into a custom sized flight case (not included), and provides enhanced impact protection during transport.



PROTEUS BRUTUS



SPECIFICATIONS

SOURCE

1200W 6,500K Bright White LED Engine
30,000 Hour Average LED Life*

*May vary depending on several factors including but not limited to: Environmental Conditions, Power/Voltage, Usage Patterns (On-Off Cycling), Control, and Dimming.

PHOTOMETRIC DATA

75,000 Total Lumen Output
CRI 70+ (82+ with HCRI Filter)
2:1 Peak Field
Zoom Range 4.5° - 45°
Beam Angle 4.4° - 39.4°
Field Angle 6.8° - 49.7°

EFFECTS

Motorized Zoom (220mm / 8.7 in Front Aperture)
Full 360° Bi-Directional Animation Wheel
Variable Frost Filter
Motorized Iris with Variable Pulse Effects
Variable 16-bit Dimming Curve Modes
High Speed Electronic Shutter and Strobe
DMX Controllable LED Refresh Rate
Pan Angle: 540°/630°
Tilt Angle: 266°

COLOR

CMY Color Mixing
Linear CTO Color Correction
6 Dichroic Colors including High CRI Filter and UV

GOBOS

5 Rotating / Indexing Interchangeable Beam Shaping + FX
Gobos

OPTIONAL FRAMING MODULE

4 Rotating Full Blackout Framing Blades
+/-45° Framing Indexing

CONTROL / CONNECTIONS

4 DMX Channel Modes (25 / 36 / 34 / 56)
16-bit Pan, Tilt and Dimming Control
Motorized Focus
DMX, RDM, Art-NET, sACN Protocol Support
(6) Button Touch Control Panel
Full Color 180° Reversible LCD Menu Display
Hibernation Mode (Power Save)
5pin XLR DMX In/Out
IP65 RJ45 ethernet In/Out
IP65 Locking Power Cable In
With Wired Digital Communication Network

SIZE / WEIGHT

Length: 25.3 in (643.6mm)
Width: 18.0 in (456.9mm)
Height: 34.2 in (869mm)
Weight: 104.1 lbs. (47.2kg)

ELECTRICAL

AC 100-240V 50/60Hz
Max Power Consumption 1,700W
-4°F to 113°F (-20°C to 45°C)

APPROVALS / RATINGS

CE | cETLus | IP65 | UKCA



Specifications are subject to change without notice ©Elation Professional 03/20/2023

Elation Professional USA | 6122 S. Eastern Ave. | Los Angeles, CA. 90040
323-582-3322 | 323-832-9142 fax | www.elationlighting.com | info@elationlighting.com

Elation Professional B.V. | Junostraat 2 | 6468 EW Kerkrade, The Netherlands
+31 45 546 85 66 | +31 45 546 85 96 fax | www.elationlighting.eu | info@elationlighting.eu



PROTEUS BRUTUS



GOBOS | COLORS | ANIMATION WHEEL

COLOR WHEEL

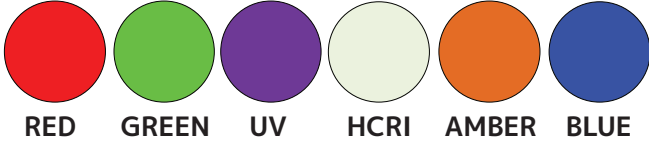

ROTATING GOBO WHEEL

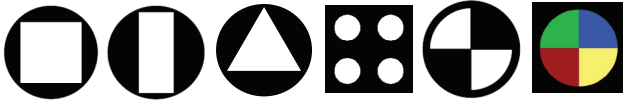

ANIMATION WHEEL

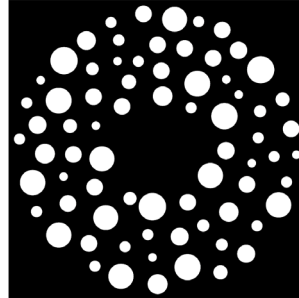

ORDERING INFORMATION

PRB201	Proteus Brutus (US Sku)
1237000259	Proteus Brutus (EU Sku)





PROTEUS BRUTUS



UNIT DIMENSIONS

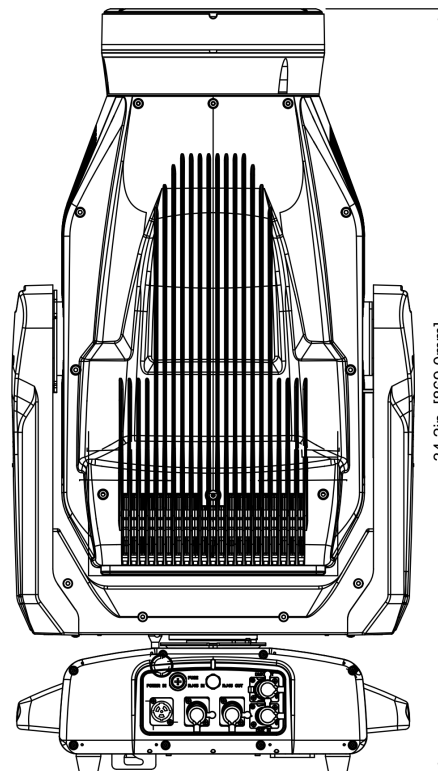
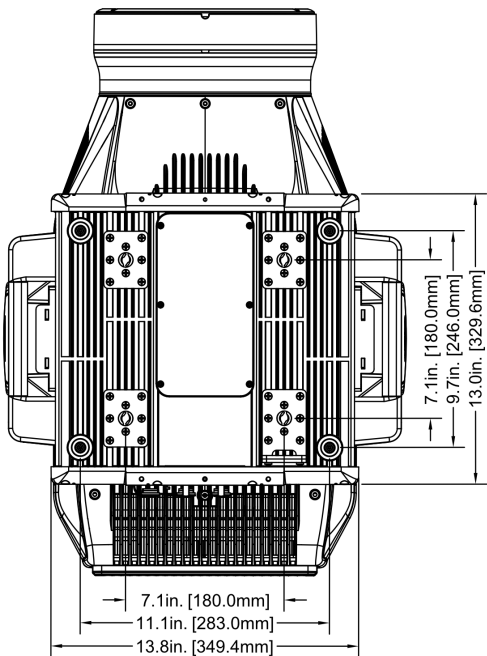
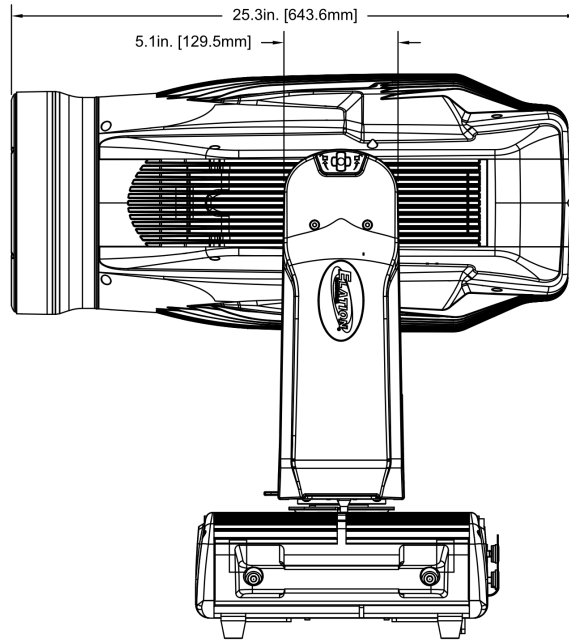
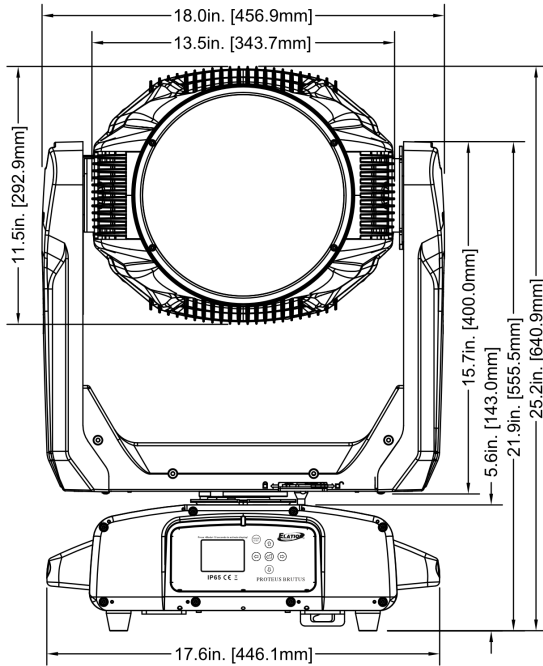

Specifications are subject to change without notice ©Elation Professional 03/20/2023

Elation Professional USA | 6122 S. Eastern Ave. | Los Angeles, CA. 90040
323-582-3322 | 323-832-9142 fax | www.elationlighting.com | info@elationlighting.com

Elation Professional B.V. | Junostraat 2 | 6468 EW Kerkrade, The Netherlands
+31 45 546 85 66 | +31 45 546 85 96 fax | www.elationlighting.eu | info@elationlighting.eu



PROTEUS BRUTUS



FOAM IN-LAY DIMENSIONS

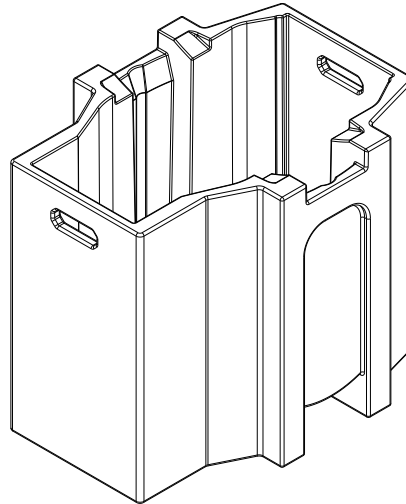
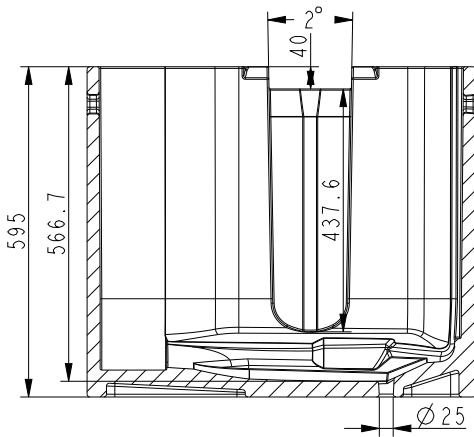
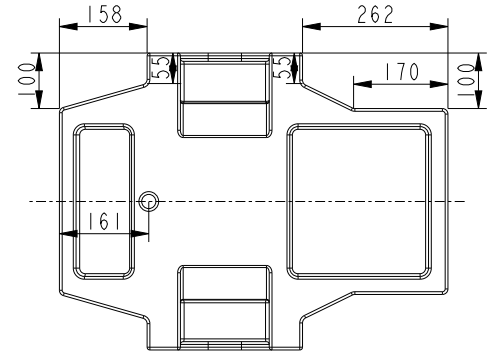
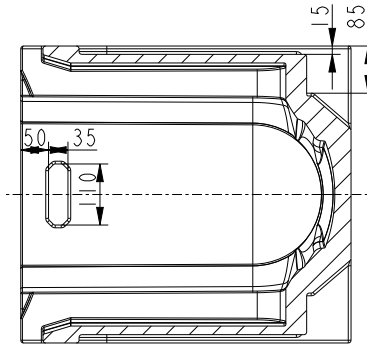
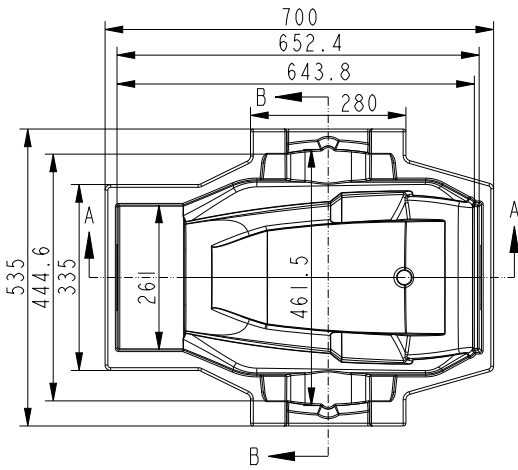

Specifications are subject to change without notice ©Elation Professional 03/20/2023

Elation Professional USA | 6122 S. Eastern Ave. | Los Angeles, CA. 90040
323-582-3322 | 323-832-9142 fax | www.elationlighting.com | info@elationlighting.com

Elation Professional B.V. | Junostraat 2 | 6468 EW Kerkrade, The Netherlands
+31 45 546 85 66 | +31 45 546 85 96 fax | www.elationlighting.eu | info@elationlighting.eu