

ERA 600 Performance

Safety and Installation Manual



Martin[®]
by HARMAN

Dimensions

All measurements are given in millimeters

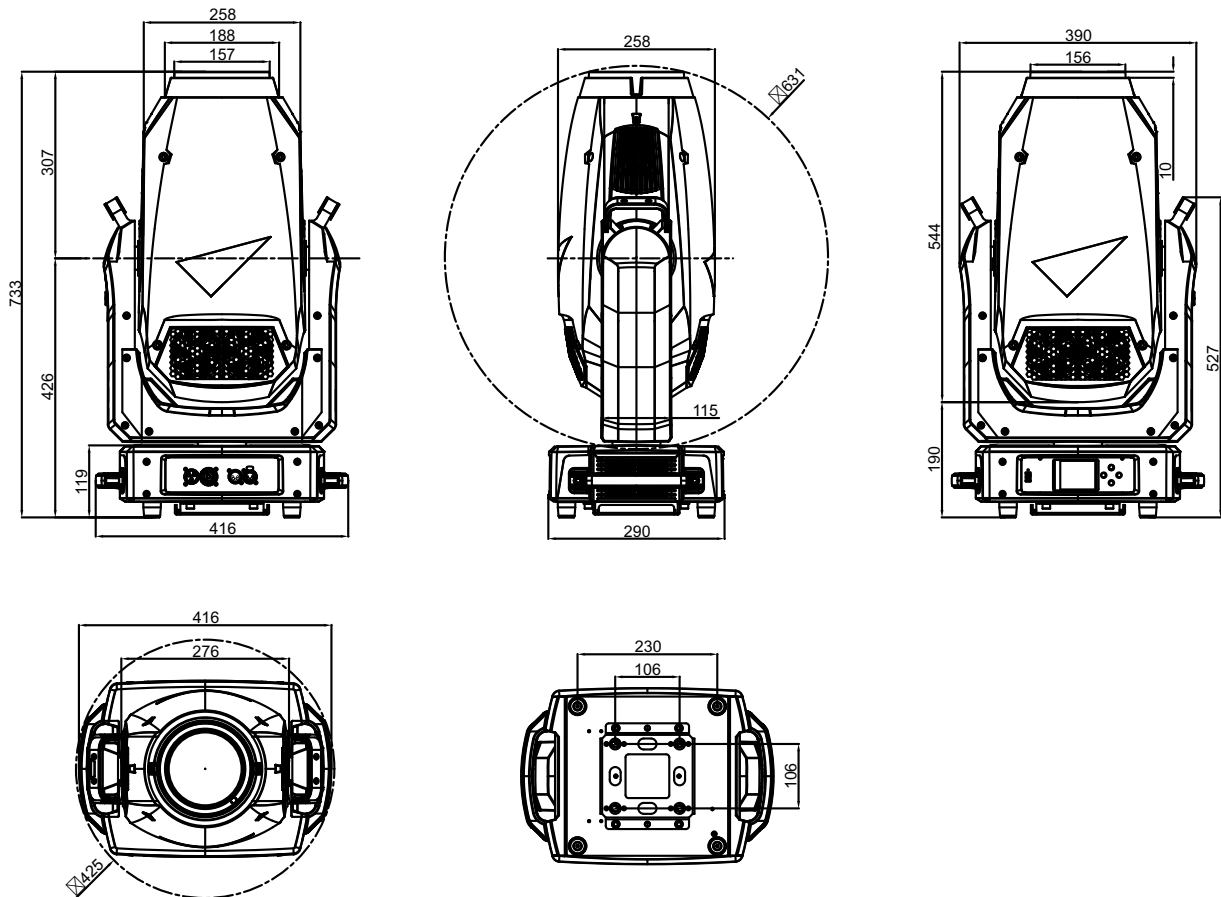

©2018-2019 HARMAN PROFESSIONAL DENMARK ApS. All rights reserved. Features, specifications and appearance are subject to change without notice. HARMAN PROFESSIONAL DENMARK ApS and all affiliated companies disclaim liability for any injury, damage, direct or indirect loss, consequential or economic loss or any other loss occasioned by the use of, inability to use or reliance on the information contained in this document. Martin is a registered trademark of HARMAN PROFESSIONAL DENMARK ApS registered in the United States and/or other countries.

HARMAN PROFESSIONAL DENMARK ApS, Olof Palmes Allé 44, 8200 Aarhus N, Denmark
HARMAN PROFESSIONAL SOLUTIONS U.S., 8500 Balboa Blvd., Northridge CA 91329, USA

www.martin.com

Contents

Safety Information.....	4
Introduction.....	8
Unpacking.....	8
Packing.....	9
Physical installation.....	10
AC power.....	13
Power input.....	13
Data links.....	15
DMX and RDM.....	15
Service and maintenance.....	16
Tilt lock.....	16
Cleaning.....	16
Lubrication.....	17
Rotating gobo replacement.....	17
Using the fixture.....	24
Applying power.....	24
Troubleshooting.....	25
Specifications.....	26

Safety Information



WARNING!

Read the safety precautions in this section before installing, powering, operating or servicing this product.

The following symbols are used to identify important safety information on the product and in this document:



DANGER!
Safety hazard.
Risk of severe injury or death.



DANGER!
Hazardous voltage. Risk of lethal or severe electric shock.



WARNING!
Fire hazard.



WARNING!
Burn hazard. Hot surface. Do not touch.



WARNING!
Intense light emission.



WARNING! Refer to user documentation.



Warning! *The ERA 600 Performance from Martin® contains components that are accessible and live at high voltage while the fixture is connected to power. These components remain under tension for up to one minute after power is disconnected.*



Warning! *Risk Group 3 product (see “Protection from eye injury” on page 6 for full details). This product produces intense light output that may be hazardous if suitable precautions are not taken. Do not view the light output with optical instruments or any device that may concentrate the beam.*



This product presents risks of severe injury or death due to fire and burn hazards, electric shock and falls if the safety precautions in this manual are not followed.

Read this manual before installing, powering or servicing the fixture. Follow the safety precautions and observe all warnings in this manual, in the ERA 600 Performance User Guide and printed on the fixture.

The latest versions of this Safety and Installation Manual and the ERA 600 Performance User Guide are available for download from the ERA 600 Performance area of the Martin website at www.martin.com. Before you install, operate or service the ERA 600 Performance, check the Martin website and make sure that you have the latest user documentation for the fixture. Document revisions are indicated at the bottom of page 2.

This product is for professional use only. It is not for household use. Respect all locally applicable laws, codes and regulations when installing, powering, operating or servicing the fixture.

Install, operate and service Martin products and accessories only as directed in their user documentation, or you may create a safety hazard or cause damage that is not covered by product warranties.

The latest software, manuals and other documentation for all Martin products are available for download at www.martin.com

Technical Support

If you have questions about how to install or operate the fixture safely, please contact Harman Professional Technical support:

- For technical support in North America, please contact: HProTechSupportUSA@harman.com
Phone: (844) 776-4899
- For technical support outside North America, please contact your national distributor.



PROTECTION FROM ELECTRIC SHOCK

- Do not expose the fixture to rain or moisture.
- Do not remove any cover from the fixture except as described under “Service and maintenance” on page 16.
- Disconnect the fixture from AC mains power before servicing it and when it is not in use.
- Ensure that the fixture is electrically connected to ground (earth).
- Use only a source of AC mains power that complies with local building and electrical codes and has both overload and ground-fault (earth-fault) protection.
- The fixture accepts AC mains power at 100-240 VAC (nominal), 50/60 Hz. Do not connect the fixture to mains power that is not within this range.
- The voltage and frequency at the power throughput socket are the same as that applied at the power input socket.
- Do not connect devices to power in a chain or circuit that will exceed the electrical ratings of any cable or connector used in the circuit.
- The fixture’s MAINS IN connector supplies mains power both to the fixture itself and to the MAINS OUT/THRU socket. The MAINS IN connector has a maximum current rating of 16 A, so you must make sure that the total current draw of any devices that are connected to the MAINS OUT/THRU socket plus the current draw of the fixture itself does not exceed 16 A total. Respect the following safety limits:
 - Do not connect more than one ERA 600 Performance fixture to the MAINS OUT/THRU socket when operating on mains power within the range 100-200 V.
 - Do not connect more than three ERA 600 Performance fixtures to the MAINS OUT/THRU socket when operating on mains power within the range 200-240 V.
- Power input and throughput cables must be rated 20 A minimum, 12 AWG or 2.5 mm² minimum conductor size and heat-resistant to 90° C (194° F) minimum. Cables must have three conductors and an outer cable diameter of 6 - 12 mm (0.24 - 0.47 in.). In North America the cable must be UL/CSA-recognized, hard usage, type SJT, SJOOW or better. In the EU, the cable must be type HO5VV-F, H07RN-F or better.
- Connect only a Neutrik powerCON TRUE1 NAC3FX-W (TOP) type cable connector to the power input socket. Connect only a Neutrik powerCON TRUE1 NAC3MX-W (TOP) type cable connector to the power throughput socket.
- Before using the fixture, check that all power distribution equipment, connectors and cables are in perfect condition and rated for the current requirements of all connected devices.
- Isolate the fixture from power immediately if the power plug or any seal, cover, cable, or other component is damaged, defective, deformed, wet or showing signs of overheating. Do not reapply power until repairs have been completed.
- The ERA 600 Performance contains components that are accessible and live at high voltage while the fixture is connected to power and that remain under tension for up to one minute after power is disconnected. Wait for at least one minute after disconnecting from power before opening any of the fixture’s covers.
- Refer any service operation not described in this manual or in the ERA 600 Performance User Guide to Martin Service or an authorized Martin Service partner.
- The light source contained in this fixture shall be replaced by Martin Service or an authorized Martin Service partner only.



PROTECTION FROM BURNS AND FIRE

- The exterior of the fixture becomes hot during use. After 5 minutes of operation a surface temperature of 70° C (158° F) shall be expected. The maximum steady state surface temperature is also 75° C (167° F). Avoid contact by persons and materials.
- Allow the fixture to cool for at least 30 minutes before handling.
- Keep all combustible materials (e.g. fabric, wood, paper) at least 0.2 m (8 in.) away from the fixture.
- Keep flammable materials well away from the fixture.
- Ensure that there is free and unobstructed airflow around the fixture.
- Provide a minimum clearance of 0.2 m (8 in.) around fans and air vents.
- Do not illuminate surfaces within 2.0 m (6.6 ft.) of the fixture.
- Do not expose the front glass to sunlight or any other strong light source from any angle. Lenses can focus the sun's rays inside the fixture, creating a potential fire hazard.
- Do not attempt to bypass thermostatic switches or fuses.
- Do not operate the fixture if the ambient temperature (Ta) exceeds 40° C (104° F).



- Do not modify the fixture in any way not described in this manual or the fixture's User Guide or install other than genuine Martin parts. Do not stick filters, masks or other materials onto any lens or other optical component. Use only accessories approved by Martin to mask or modify the light beam.

PROTECTION FROM EYE INJURY



- This fixture corresponds to Risk Group 3 according to EN 62471 when all photobiological risks are considered and Risk Group 2 product according to IEC/TR 62778 for blue light only. It emits possibly hazardous optical radiation. It falls into the Risk Group categories shown below according to both EN 62471 and IEC/TR 62778 under worst-case conditions:

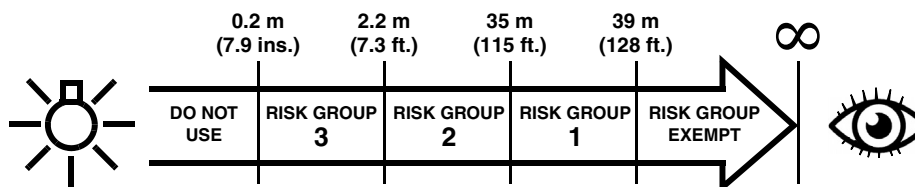

- At a distance of less than 2.2 m (7.3 ft.) from the fixture, the light output can potentially cause eye or skin injury before an exposed person's natural aversion responses (blink reflex and reaction to skin discomfort) can protect them. At distances greater than 2.2 m (7.3 ft.), potential eye and skin injury hazards from the light output are normally prevented by natural aversion reflexes.
- Position the fixture so that persons cannot be exposed to the fixture's light output at a distance of less than 2.2 m (7.3 ft.) from the fixture, and so that prolonged staring into the light output at less than 35 m (115 ft.) from the fixture is not expected.
- Do not look directly into the fixture's light output.
- Do not look at LEDs with magnifiers, telescopes, binoculars or similar optical instruments that may concentrate the light output.
- Ensure that persons are not looking at the fixture when the fixture lights up suddenly. This can happen when power is applied, when the fixture receives a DMX signal, or when certain control menu items are selected.
- Disconnect the fixture from power at all times when the fixture is not in use.
- Provide well-lit conditions to reduce the pupil diameter of anyone working on or near the fixture.

PROTECTION FROM INJURY



- Fasten the fixture securely to a fixed surface or structure when in use. The fixture is not portable when installed.
- Do not lift or carry the fixture alone.
- Use two evenly spaced omega brackets with clamps to suspend the fixture from rigging structures. Do not use only one clamp.
- When clamping the fixture to a truss or other supporting structure, use two half-coupler clamps. Do not use G-clamps, quick-trigger clamps or any other type of clamp that does not completely encircle the supporting structure when fastened.
- When suspending the fixture, check that the supporting structure and all hardware used to suspend the fixture can hold at least six (6) times the weight of all devices suspended from them and that the installation respects all similar safety factors that are required by locally applicable regulations. Check that the structure and hardware are in perfect condition and suitable for their purpose.
- If the fixture is installed in a location where it may cause injury or damage if it falls, install as described in this manual a secondary attachment such as a safety cable that is approved by an official body such as TÜV as a safety attachment for the weight that it secures. The safety cable must comply with EN 60598-2-17 Section 17.6.6 or BGV C1 / DGUV 17, and must be capable of bearing a static suspended load at least six times (or more if required by locally applicable regulations) the weight that it secures.
- Eliminate as much slack as possible in the safety cable (by looping it more than once around the rigging truss, for example). Make sure that, if the primary attachment fails, the fixture cannot fall more than 20 cm (8 inches) maximum before the safety cable catches it.
- If the safety cable attachment point becomes deformed, do not suspend the fixture. Have the fixture repaired by an authorized Martin service partner.
- Check that all external covers and rigging hardware are securely fastened.

- Block access below the work area and work from a stable platform whenever installing, servicing or moving the fixture.
- Allow enough clearance around the head to ensure that it cannot collide with a person or object such as another fixture when it moves.

Introduction

Thank you for selecting the ERA 600 Performance from Martin®. This moving-head spotlight offers the following features:

- Bright 550 W, 6500 K LED light source
- 19 000 lumens output
- Crisp optics with flat field
- 1:8 fast zoom
- CMY color mixing
- Linear CTO – daylight to tungsten CCT control and expansion of the CMY palette
- 7-slot color wheel for added color choice and split color effects
- Full curtain framing blades with +/- 60° rotation of entire system for flexible shape generation
- 7 rotating/indexing gobos
- 8 static gobos for great morphing effects
- Animation wheel with continuous bi-directional rotation
- Fast and tight iris
- Two prisms – 4-facet and linear – with rotation and indexing control
- Soft frost that leaves gobo artwork visible with a beautiful soft edge
- Compact, low weight design

For the latest firmware updates, documentation, and other information about this and all Martin products, please visit the Martin website at <http://www.martin.com>

Unpacking

The ERA 600 Performance is packed in a cardboard box that is designed to protect the fixture during initial shipment only. We strongly recommend that you store and transport fixtures in the flightcases available from Martin (or custom flightcases of the same quality).

This Safety and Installation Manual is included with the fixture. The ERA 600 Performance User Guide, containing full details of setting up, controlling and monitoring the fixture, is available for download from the ERA 600 Performance area of the Martin website at www.martin.com. If you have any difficulty locating this document, please contact your Martin supplier for assistance.

Tilt lock

Check that the tilt lock is released before applying power to the fixture.

See Figure 1. Release the tilt lock by sliding the tilt lock button (arrowed) to the **Unlocked** position.

You can reapply the tilt lock by first checking that the power is off and then sliding the tilt lock button back to the **Locked** position.

Release the tilt lock before putting the fixture into its flightcase for transport or storage.

Packing

Important! *Allow the fixture to cool for 30 minutes and release the tilt lock before packing it in its flightcase.*

A rugged two-unit flightcase is available from Martin for the ERA 600 Performance.

The flightcase is designed to support the head without the tilt lock (see Figure 1) in the Unlocked position. Release the tilt lock before putting a fixture into a flightcase for transport. Leaving the tilt lock applied may cause damage that is not covered by the product warranty.

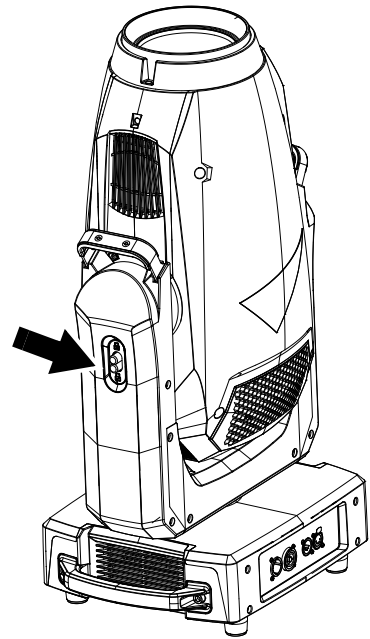

Figure 1: Tilt lock

Physical installation



Warning! The ERA 600 Performance has a powerful pan motor. The torque reaction when the head is panned suddenly can cause the base to move if the fixture is standing unsecured on a surface. Do not apply power to the ERA 600 Performance unless the base is securely fastened to a stable surface or structure.

Warning! Use two clamps to rig the fixture. Do not hang the fixture from only one clamp. Lock each clamp with both 1/4-turn fasteners. Fasteners are locked only when turned a full 90° clockwise.

Warning! When suspending the fixture above ground level, secure it against failure of primary attachments by attaching a safety cable that is approved as a safety attachment for the weight of the fixture to the attachment point in the base. Do not use the carrying handles for secondary attachment.

Warning! When clamping the fixture to a truss or other structure at any other angle than with the yoke hanging vertically downwards, use two clamps of half-coupler type. Do not use any type of clamp that does not completely encircle the structure when fastened.

Warning! You can fasten the fixture to a surface with ratchet straps passed through the carrying handles so that the fixture cannot fall over, but do not over-tighten the ratchet straps or you may damage the carrying handles and leave the fixture in an unsafe condition.



Warning! Position or shade the head so that the front lens will not be exposed to sunlight or another strong light source from any angle – even for a few seconds. See Figure 2. The ERA 600 Performance's lens can focus the sun's rays, creating a potential fire hazard and causing damage.

Important! Do not point the output from other lighting fixtures at the ERA 600 Performance, as powerful light can damage the display.

See Figure 2. Lenses can focus sunlight and strong light, presenting a risk of fire and damage to the fixture. Shield or shade the head if necessary.

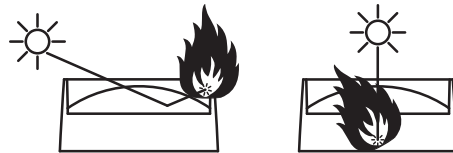

Figure 2: Potential sunlight damage

The ERA 600 Performance can be fastened to a surface such as a stage or clamped to a truss in any orientation.

Clamps must be half-coupler type (see Figure 4) or equivalent type that fully encircles the truss unless the fixture is installed with the yoke hanging vertically downwards, in which case other clamp types that are approved for the supported weight may be used.

The mounting points in the base allow omega brackets and rigging clamps to be fastened as shown in Figure 3.

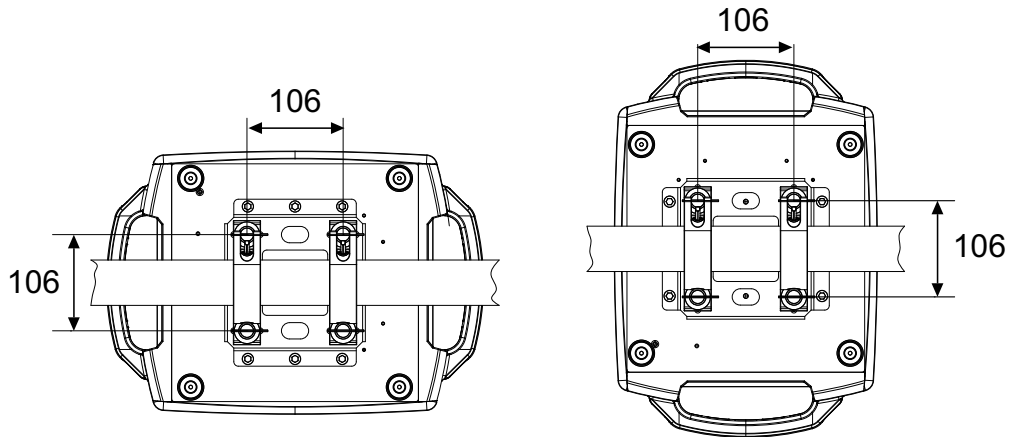
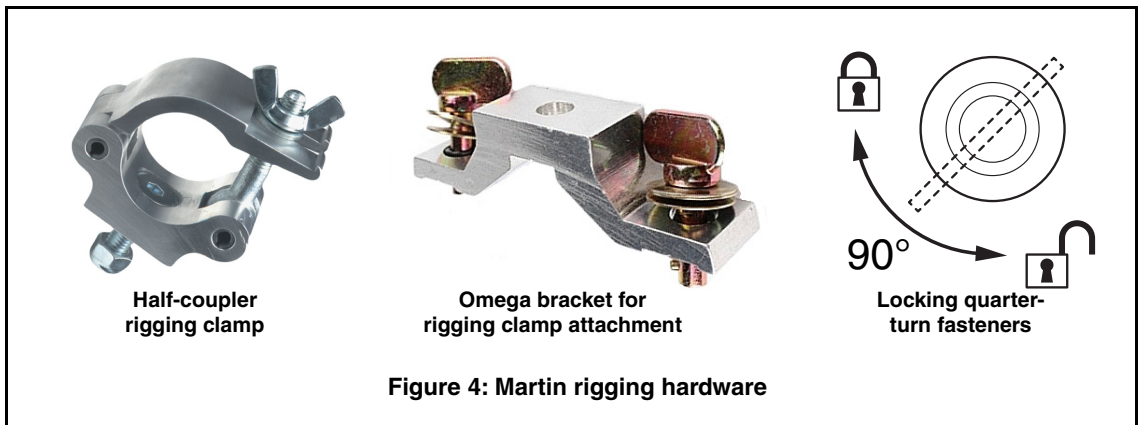

Figure 3: Clamp bracket positions

Clamping the fixture to a truss

1. Check that all rigging hardware is undamaged and can bear at least six (6) times the weight of the fixture or as required by locally applicable regulations. Check that the supporting structure can safely bear the weight of all installed fixtures, clamps, cables, auxiliary equipment, etc. and complies with locally applicable regulations.
2. Bolt each rigging clamp securely to an omega bracket with an M12 bolt (minimum grade 8.8) and self-locking nut.



3. See Figure 3 on page 11. Align the first clamp and bracket with 2 mounting points in the base, and engage both the clamp bracket's quarter-turn fasteners in corresponding sockets in the base. See Figure 4. Turn the levers on the quarter-turn fasteners a full 90° clockwise to lock. Repeat for the second clamp.
4. Block access under the work area. See Figure 5. Note the position of the arrow marked **FRONT** on the base of the fixture. Working from a stable platform, hang the fixture on the truss with the arrow marked **FRONT** facing towards the area to be illuminated. Tighten the rigging clamps.

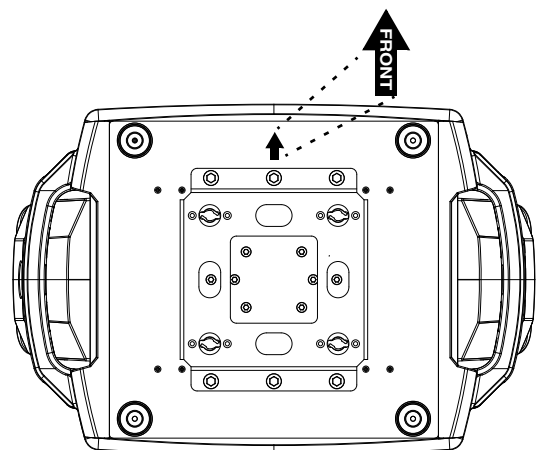

Figure 5: Front of fixture

5. See Figure 6. Install a safety cable that is approved as a safety attachment for the weight of the fixture by looping it through one of the four safety cable attachment points (arrowed) in the bottom of the base and around a secure anchoring point so that the safety cable will catch the fixture if a primary attachment fails. Remove as much slack as possible from the safety cable (by looping it more than once around the truss bar, for example).
6. Check that the tilt lock is released. Check that there are no combustible materials within 0.2 m (8 in.) or surfaces to be illuminated within 2.0 m (6.6 ft.) of the fixture, and that there are no flammable materials nearby.
7. Check that there is no possibility of the head colliding with objects or other fixtures.
8. Check that other lighting fixtures cannot project light at the ERA 600 Performance, as powerful illumination can damage the fixture's display.

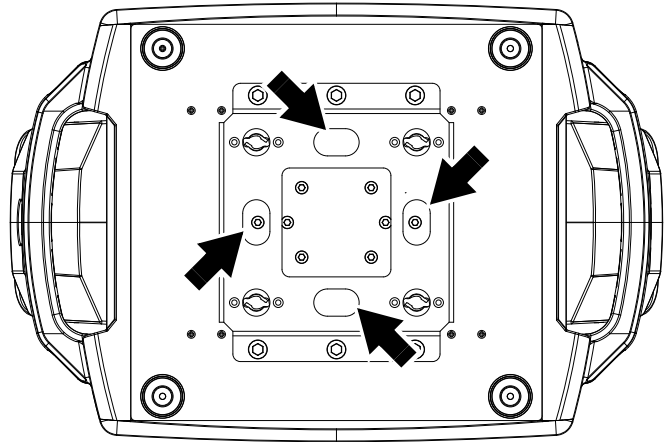

Figure 6: Safety cable attachment points

AC power



Warning! Read “Safety Information” on page 4 before connecting the fixture to AC mains power. Note in particular that you must not connect more than one ERA 600 Performance fixture to the MAINS OUT/THRU socket when operating on 100-200 V mains power, and you must not connect more than three ERA 600 Performance fixtures to the MAINS OUT/THRU socket when operating on 200-240 V mains power.



For protection from electric shock, the fixture must be electrically connected to ground (earth). The AC mains power distribution circuit must be equipped with a fuse or circuit breaker and ground-fault (earth-fault) protection.



Power input

Important! Connect the ERA 600 Performance directly to AC power. Do not connect it to a dimmer system; doing so may damage the fixture.

The ERA 600 Performance features an auto-sensing switch-mode power supply that automatically adapts to AC mains power at 100-240 VAC (nominal), 50/60 Hz. Do not connect the fixture to power that is not within this range.

The ERA 600 Performance requires a power input cable with a Neutrik powerCON TRUE1 NAC3FX-W (TOP) female cable connector for AC mains power input. The cable must meet the requirements listed under “Protection from electric shock” on page 5. Martin can supply suitable cables with female TRUE1 input connectors 1.5 m (4.9 ft.) or 5 m (16.4 ft.) long. Alternatively, Martin can supply loose female TRUE1 input connectors (see “Accessories” on page 34).

Connection to an AC mains power source

The power cable can be hard-wired to a building installation circuit or fitted with a mains plug (cord cap) to allow connection to local AC mains power outlets.

If you install a mains plug on the power cable, install a grounding-type (earthed) plug rated minimum 16 A, 250 V (example rating: EN 60309-2 CEE 2P+E 16 A/250 VAC), following the plug manufacturer’s instructions. Table 1 shows some possible mains power pin identification schemes; if the pins are not clearly identified, or if you have any doubts about proper installation, consult a qualified electrician.



Wire Color (US)	Wire Color (EU)	Pin	Symbol	Screw (US)
black	brown	live	L	yellow or brass
white	blue	neutral	N	silver
green	yellow/green	ground (earth)	 or 	green

Table 1: Cord cap (mains plug) connections

If you need to install a Neutrik powerCON TRUE1 connector on a power cable, follow the instructions on the Neutrik website at www.neutrik.com.

Linking more than one fixture to power in a chain

If you obtain a 12 AWG / 2.5 mm² power input cable and 12 AWG / 2.5 mm² power relay cables from Martin (see “Accessories” on page 27), you can relay mains power from one fixture to another by connecting fixtures to power in a linked daisy-chain, MAINS OUT throughput socket to MAINS IN input socket. If you create a linked daisy-chain like this, you must respect the following safety limits, or you may create a risk of fire and electric shock.

Using 12 AWG / 2.5 mm² cables from Martin, you can link:

- maximum two (2) ERA 600 Performance fixtures total in one chain at 100-200 V, or
- maximum four (4) ERA 600 Performance fixtures total in one chain at 200-240 V.

If you connect more than one fixture to power in a daisy-chain, we recommend that you draw power from a circuit that is protected by a type D MCB (Miniature Circuit Breaker). This will avoid the breaker tripping unnecessarily because of inrush current. If the only available power circuits have type C MCBs, you may need to connect maximum two (2) fixtures per daisy-chain at 200-240 V in order to avoid tripping breakers unnecessarily.

Connecting to power



Warning! *The ERA 600 Performance does not have a power On/Off switch. As soon as you connect an energized power input cable to the fixture or apply power to a power input cable that has already been connected, the fixture will power up: check that there is no safety risk from head movement or intense light output.*

To apply power to the ERA 600 Performance:

1. Check that the tilt lock is released and that the base is held securely. Be prepared for the fixture to light up and the head to move suddenly when power is applied.
2. See Figure 7. line up the keys in the power input cable's TRUE1 connector with the keyways in the MAINS IN socket (arrowed). Insert the connector into the socket and twist clockwise to engage. If the connector seems difficult to twist, remove it from the socket, check that you have lined up the keyways correctly and try again – do not use excessive force. Make sure that the connector latch clicks and that the connector is locked into the socket.
3. Apply power to the power input cable to power the fixture on.

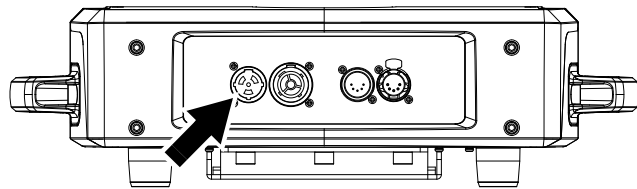

Figure 7: Mains input socket

To disconnect the ERA 600 Performance from power, pull the release latch on the connector towards you to unlock the connector, twist the connector counter-clockwise, and then withdraw it from the MAINS IN socket.

Data links

Important! Shut down power to the fixture before connecting to or disconnecting from data.

DMX and RDM

The ERA 600 Performance has 5-pin locking XLR sockets for DMX and RDM input and output (see **A** in Figure 8). The default pin-out on both sockets is:

- pin 1 to shield
- pin 2 to data 1 cold (-)
- pin 3 to data 1 hot (+).

Pins 4 and 5 are not used by the fixture but are bridged between input and output sockets. These pins can therefore be used as a pass-through connection for an additional data signal if required.

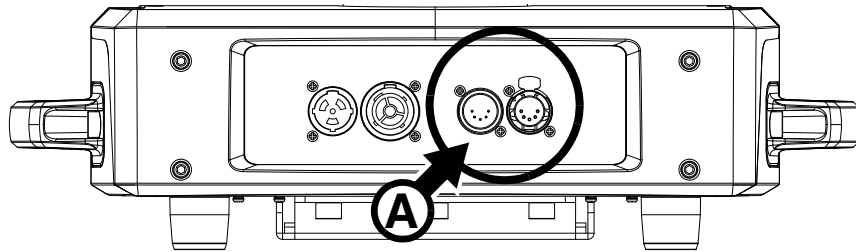

Figure 8: Data connections

Tips for reliable data transmission

- Use shielded twisted-pair cable designed for RS-485 devices: standard microphone cable cannot transmit control data reliably over long runs. 24 AWG cable is suitable for runs up to 300 meters (1000 ft). Heavier gauge cable and/or an amplifier is recommended for longer runs.
- To split the data link into branches, use a *Martin RDM 5.5 Splitter* optically isolated splitter-amplifier (see “Related Items” on page 28).
- Do not overload the DMX data link. You can connect up to a maximum of 32 devices on a serial DMX link.
- Install a DMX termination plug on the last fixture on the link.

Connecting to data via DMX cable

To connect the ERA 600 Performance to DMX and/or RDM data carried over DMX cable:

1. Shut down power to the fixture.
2. Connect the DMX data output from the controller to the ERA 600 Performance’s data input (male XLR) socket using good-quality DMX cable.
3. Run DMX cable from the ERA 600 Performance’s data output (female XLR) socket to the data input of the next fixture and continue until the link is complete.
4. Terminate the data link by connecting a 120 Ohm, 0.25 Watt resistor between the data 1 hot (+) and cold (-) conductors at the data output of the last fixture on the link. If the link is divided into branches using a DMX splitter, terminate each branch of the link.
5. You can now apply power.

Service and maintenance



Warning! Read “Safety Information” on page 4 before servicing the ERA 600 Performance.

Warning! Disconnect the fixture from AC mains power and allow to cool for at least 30 minutes before handling. Do not stare into the light output. Be prepared for the fixture to light and move suddenly when connected to power.



Warning! The ERA 600 Performance contains components that are accessible and live at high voltage while the fixture is connected to power and that remain under tension for one minute after power is disconnected. Only qualified technicians are permitted to open the fixture. Users may carry out external cleaning and replace gobos as described in this section, following the warnings and instructions provided, but any service operation not described in this manual or in the fixture’s User Guide must be referred to an authorized Martin service technician.



Important! Excessive dust, smoke fluid, and particle buildup degrades performance, causes overheating and will damage the fixture. Damage caused by inadequate cleaning or maintenance is not covered by the product warranty.



The user must clean the ERA 600 Performance periodically to maintain optimum performance and cooling. The user may also upload firmware (fixture software) to the fixture via the DMX data input port or USB port using firmware and instructions from Martin. All other service operations on the ERA 600 Performance must be carried out by Martin, its approved service agents or trained and qualified personnel using the official Martin service documentation for the ERA 600 Performance.

Installation, on-site service and maintenance can be provided worldwide by the Martin Professional Global Service organization and its approved agents, giving owners access to Martin’s expertise and product knowledge in a partnership that will ensure the highest level of performance throughout the product’s lifetime. Please contact your Martin supplier for details.

It is Martin policy to apply the strictest possible calibration procedures and use the best quality materials available to ensure optimum performance and the longest possible component lifetimes. However, optical components are subject to wear and tear over the life of the product, resulting in gradual changes in color over many thousands of hours of use. The extent of wear and tear depends heavily on operating conditions and environment, so it is impossible to specify precisely whether and to what extent performance will be affected. However, you may eventually need to replace optical components if their characteristics are affected by wear and tear after an extended period of use and if you require fixtures to perform within very precise optical and color parameters.

Tilt lock

The tilt position of the head can be locked for service. See Figure 9. Slide the lock button up towards the closed padlock symbol to lock the head and down to unlock.

Important! Release the tilt lock before applying power to the fixture and before packing the fixture in its flightcase.



Figure 9. Tilt lock

Cleaning

Regular cleaning is very important for fixture life and performance. Buildup of dust, dirt, smoke particles, fog fluid residues, etc. degrades the fixture’s light output and cooling ability.

Cleaning schedules for lighting fixtures vary greatly depending on the operating environment. It is therefore impossible to specify precise cleaning intervals for the ERA 600 Performance. Cooling fans suck in airborne dust and smoke particles, and in extreme cases fixtures may require cleaning after surprisingly few hours of operation. Environmental factors that may result in a need for frequent cleaning include:

- Use of smoke or fog machines.
- High airflow rates (near air conditioning vents, for example).

- Presence of cigarette smoke.
- Airborne dust (from stage effects, building structures and fittings or the natural environment at outdoor events, for example).

If one or more of these factors is present, inspect fixtures within their first few hours of operation to see whether cleaning is necessary. Check again at frequent intervals. This procedure will allow you to assess cleaning requirements in your particular situation. If in doubt, consult your Martin dealer about a suitable maintenance schedule.

Follow these precautions when cleaning the fixture:

- Work in a clean, dry, well-lit area.
- Use gentle pressure only. Do not use any product that contains abrasives. Do not use solvents. Use care when cleaning optical components: surfaces are fragile and easily scratched.
- Use a vacuum cleaner – do not use a pressurized air jet. A vacuum cleaner will remove dirt from the fixture and from the area where you are working. An air jet may blow dirt into the fixture, and this can cause visible objects in projections and possibly even damage to the fixture.
- Do not apply a strong vacuum directly to a cooling fan, as the strong airflow may spin the fan blades fast enough to cause damage. Instead, hold the vacuum cleaner nozzle a few centimeters away from the fan and dislodge dust with a soft brush.

Cleaning procedure

To clean the fixture:

1. Disconnect the fixture from power and allow it to cool for at least 30 minutes.
2. Vacuum dust and loose particles from the outside of the fixture and the air vents at the back and sides of the head and in the base, using a soft brush to help dislodge dust.
3. Clean the front glass on the front of the head by wiping gently with a soft, clean, lint-free cloth moistened with a weak detergent solution. Do not rub the surface hard: lift particles off with a soft repeated press. Dry with a soft, clean, lint-free cloth or low-pressure compressed air. Remove stuck particles with an unscented tissue or cotton swab moistened with glass cleaner or distilled water.
4. Check that the fixture is dry before reapplying power.

Lubrication

The ERA 600 Performance does not require lubrication under normal circumstances. Moving parts can be checked and a long-lasting Teflon-based grease reapplied by a Martin service partner if necessary.

Rotating gobo replacement

See the ERA 600 Performance User Guide, available for download from www.martin.com, for names, illustrations and part numbers of the gobos installed as standard.

The ERA 600 Performance uses specially designed borosilicate 3.3 rotating gobos with a heavy matted aluminum coating. All gobos are interchangeable, but replacement gobos must match the dimensions, construction and quality of the gobos supplied as standard. The gobos are a custom size: 23.0 mm +0/-0.2 mm external diameter, 19 mm image diameter.

Optical components have fragile coatings and are exposed to very high temperatures. Handle and store components with care.

Avoiding damage to gobos

Follow these precautions when handling, using and storing gobos:

- Do not use gobos with dark coatings on either side, as these will absorb heat – either directly from the light source or reflected back from other optical components – and will not be durable.
- Do not use metal gobos in the ERA 600 Performance: their durability may be reduced when used in this fixture.
- Store all gobos in a dust-free environment with approx. 50% humidity.
- Wear clean nitrile cleanroom gloves when handling gobos.
- Avoid scratching coated and uncoated sides.
- Do not place a gobo with the coated side face-down on any surface.

- Avoid touching the other gobos when removing a gobo from a rack: the sharp edge of one gobo can scratch the others.
- Keep gobos perfectly clean to reduce the risk of heat damage.
- When cleaning gobos, use a repeated dabbing action rather than a rubbing action. When rinsing, use distilled or even better deionized water to avoid residue that will appear as drying marks.
- If possible, clean the coated side of gobos with dust and oil-free compressed air only. If the coated side is contaminated with oil, clean with isopropyl alcohol and optics cleaning tissues.
- Clean the uncoated side of gobos with isopropyl alcohol or photographic quality lens-cleaner and optics cleaning tissues.
- Do not try to clean gobos in an ultrasound bath, as this may cause delamination of the coating.
- Do not use acidic or alkaline cleaning solutions, as they will attack the aluminum coating.
- Correct gobo orientation is critical. Read the guidelines given later in this chapter carefully before installing a gobo.

Opening the head for access

To open the head for access to the rotating gobos:

1. Disconnect the fixture from power and allow to cool for 30 minutes.
2. Place the fixture on a suitable work surface.

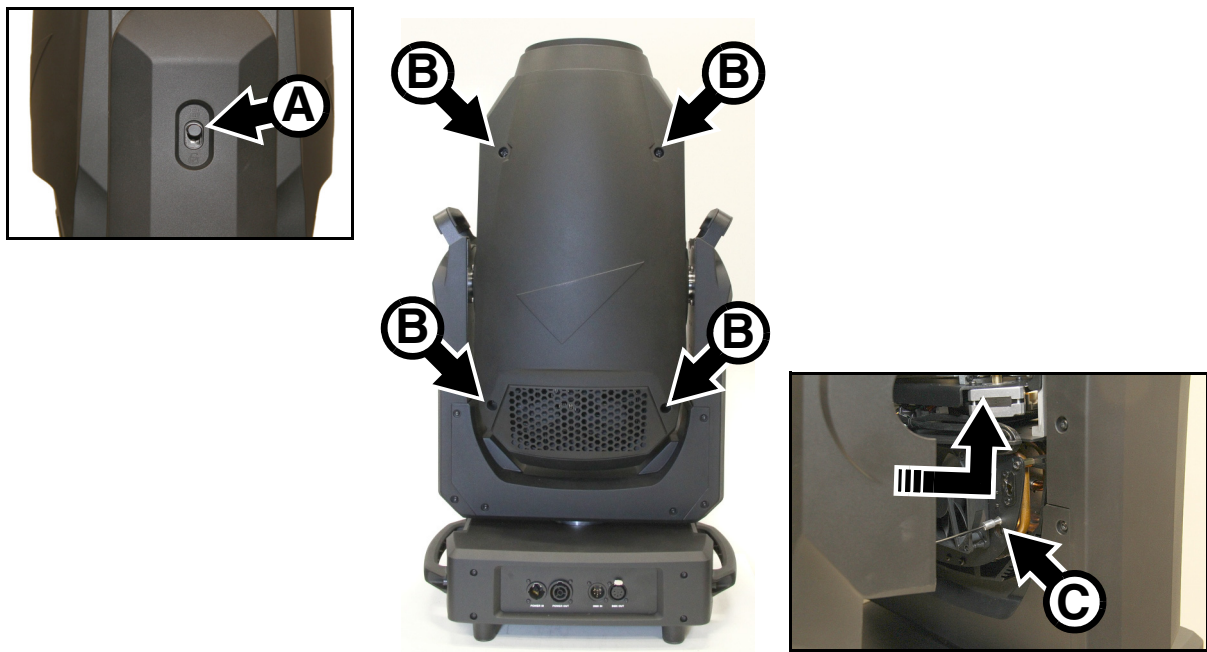

Figure 10: Removing the head covers

3. See Figure 10. Apply the tilt lock **A**.
4. Remove the four retaining screws **B** from one of the head covers and lift the cover away from the head slightly. Press the retaining clip **C** on the cover's safety wire in towards the head chassis, slide the clip until you can remove it, and then remove the safety wire and head cover completely from the fixture.
5. Remove the other head cover in the same way.

When closing the head, follow the above procedure in reverse. Check that the head covers are held securely after you have reinstalled them, and release the tilt lock before reapplying power or packing the ERA 600 Performance in its flightcase.

Replacing a rotating gobo

Important: Different screw sizes and types are used on the modules and components inside the head. Make sure that you do not mix them up. Apply a small quantity of Loctite 222 to the threads of all the screws mentioned in this section when you reinstall them.

To replace a rotating gobo:

1. Remove both head covers as described in the previous section.

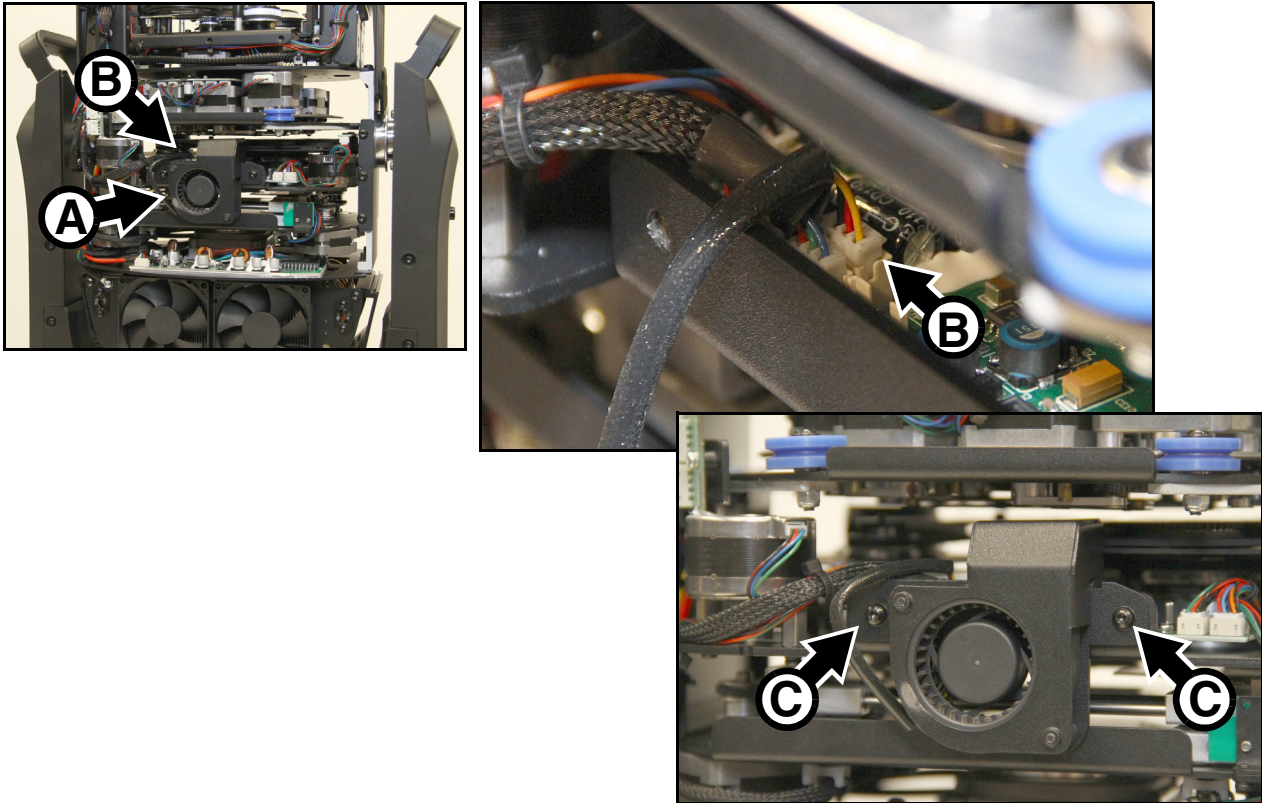

Figure 11: Removing the effects fan

2. See Figure 11. Position the head so that the effects cooling fan **A** is facing you. You are now looking at the bottom of the head.
3. Unplug the effects fan connector **B**, remove and keep the fan's two retaining screws **C** and remove the fan from the head.
4. See Figure 12. Locate the effects module connector (arrowed) and disconnect it from the PCB on the left of the head. Let the connector and wireset hang free.

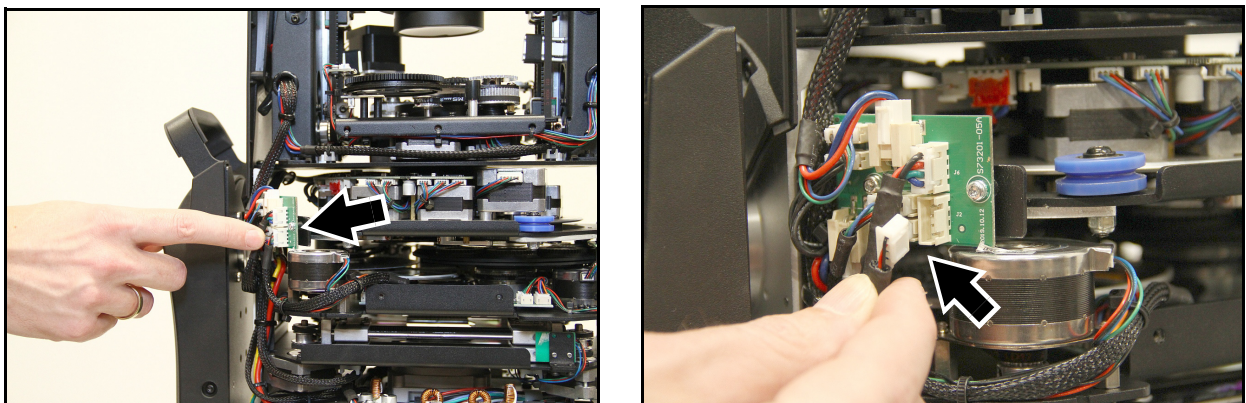

Figure 12: Disconnecting the effects module

5. See Figure 13. Rotate the head through 180° so that you are looking at the top of the head. Remove the six screws (arrowed) from the effects module retaining plates and keep the plates and screws for re-use.

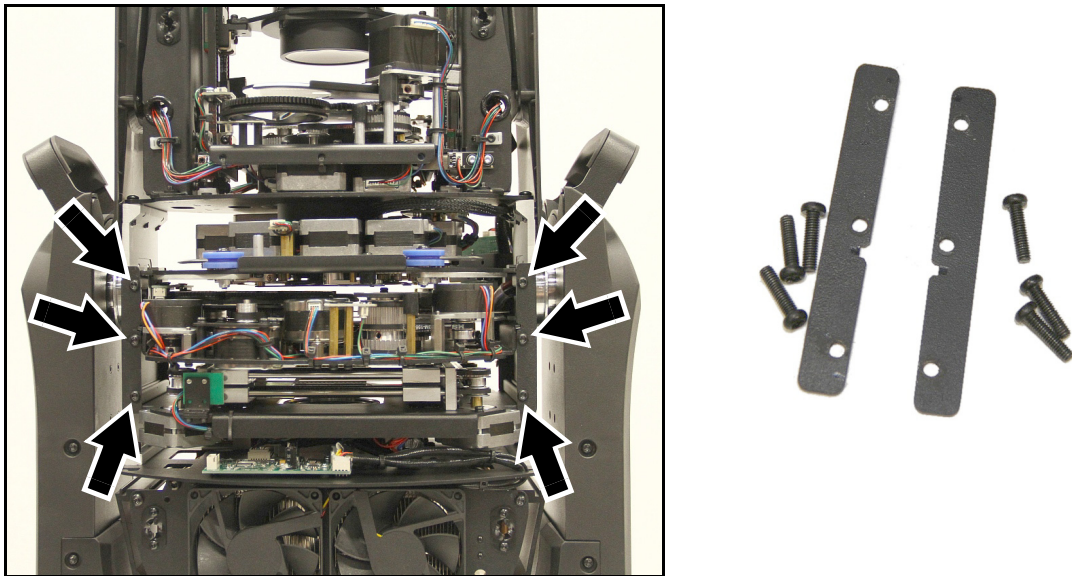

Figure 13: Removing the effects module retaining plates

6. See Figure 14. Slide the effects module carefully out of the head. If any wires or components become caught, especially on the module above, move them out of the way.

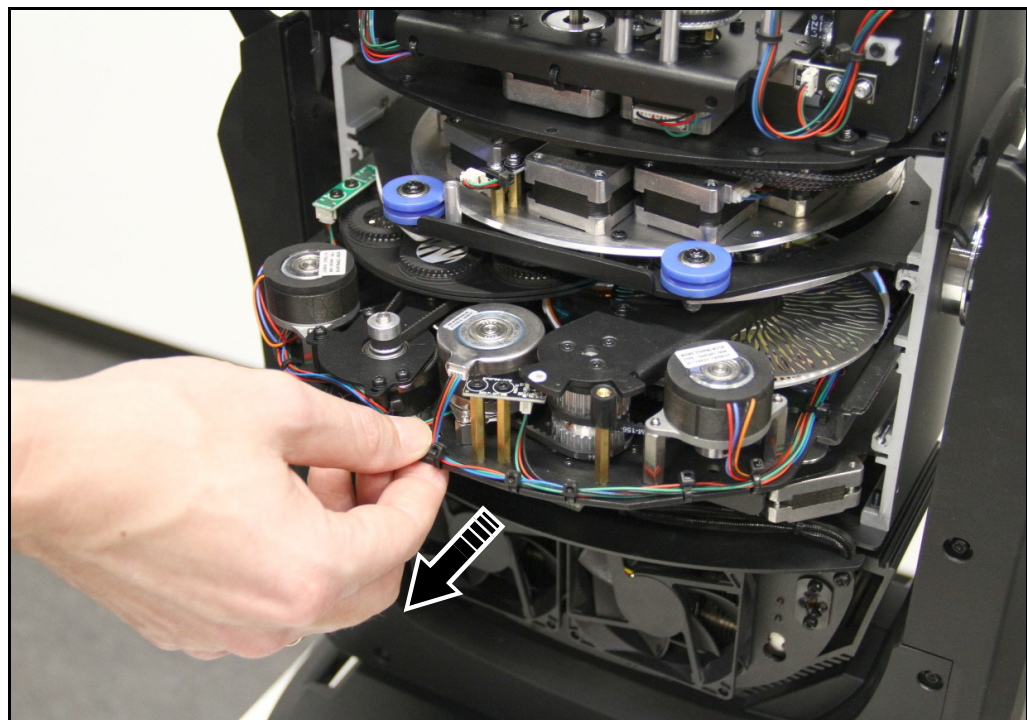

Figure 14: Removing the effects module

7. Place the effects module on a clean work surface with the rotating gobo wheel facing upwards.

8. See Figure 15. Note the position of the reference marks in the gobo drive wheel **A** and goboholder **B**. Note also the position of the goboholder positioning magnet **C** and gobo wheel positioning magnet **D**. Each time you remove a goboholder from the wheel, turn the drive wheel (twice if necessary) until the marks exactly line up.

We recommend that you only remove one goboholder at a time. Avoid turning the drive wheel while a goboholder is out of the gobo wheel. This will keep the gobos in their correct orientation, avoiding the need to reprogram cues or adjust gobo positions in the fixture because a gobo orientation has changed during service. Note that if necessary you can adjust the home positions of rotating gobos at any time using the SERVICE → CALIBRATION menu in the control panel.

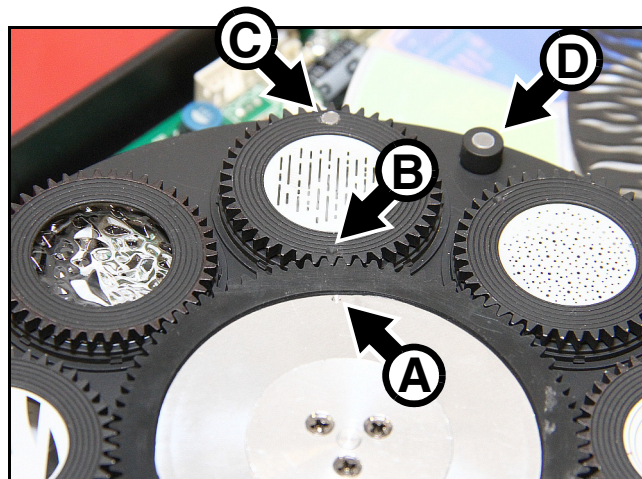

Figure 15: Goboholder orientation marks

9. See Figure 16. With the reference marks lined up, lift the outside edge of the goboholder up slightly and pull the goboholder out of the gobo wheel. Note how the goboholder tongue (arrowed) engages in a recess in the gobo drive wheel. You will need to reinstall the goboholder with the tongue in the same position in the drive wheel.

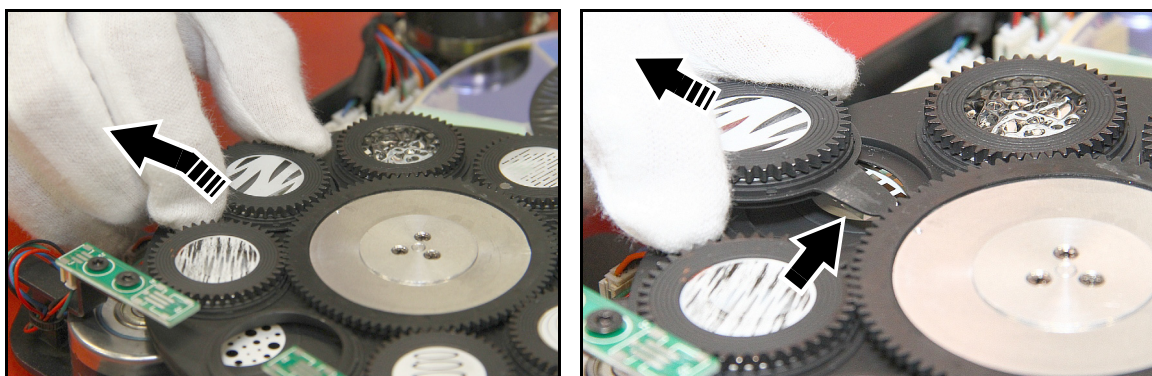

Figure 16: Removing a rotating gobo

10. For details of replacing a gobo in a goboholder, see the next section of this manual.
11. When reinstalling a goboholder in the gobo wheel, use the above procedure in reverse as a guide.

Do not apply lubricant to the goboholder or drive wheel.

Line up the reference marks in the goboholder and gobo drive wheel and push the tongue correctly into its location in the gobo drive wheel when you install the goboholder. Check that the goboholder is held securely in the wheel after you have installed it.

Installing a gobo in a goboholder

All the rotating gobos in the ERA 600 Performance are held in their holders by springs and can be removed from their holders as described below.

Note that the fused glass gobo Limbo (Crystal) has a specially designed goboholder and spring to cater for the extra thickness of the gobo. Fused glass gobos, their goboholders and their retaining springs are not interchangeable with the other gobos and goboholders.

Gobo orientation

Make sure that you install gobos facing in the correct direction, or they may suffer heat damage. The orientations shown in Figure 17 are correct in most cases, but consult your Martin dealer or gobo supplier if you are in any doubt about the orientation of a specific gobo type.

Coated Glass Gobos

The heavy matted aluminum coated borosilicate gobos in the ERA 600 Performance are factory-installed with the more reflective sides facing towards the LED light source. Replacement gobos must also be installed with more reflective sides facing the LEDs in order to avoid heat damage.

More reflective side towards LEDs

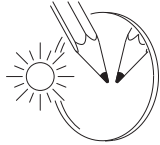

To minimize the risk of gobo overheating and damage, turn the more reflective side of a coated gobo towards the lamp.

Less reflective side away from LEDs

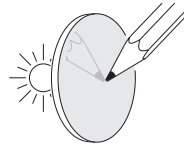

The less reflective side of a coated gobo will absorb less heat if it faces away from the lamp.

Textured Glass Gobos

Textured side towards LEDs

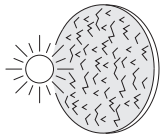

Textured glass gobos in the ERA 600 Performance sit most squarely in the gobo wheel with the textured side towards the LED light source. If in doubt, consult your Martin dealer or gobo supplier. We recommend that textured glass gobos are glued into the goboholder.

Smooth side away from LEDs

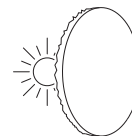
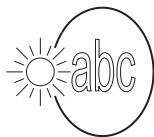

Image / text Gobos

True image towards LEDs



Reversed image away from LEDs



Gobos that have a specific left/right orientation (such as text gobos) will appear correctly in the projection if they appear correctly when viewed from the side that faces towards the LED light source.

Figure 17. Correct gobo orientation

In the ERA 600 Performance:

- The side of the goboholder with the gobo retaining spring faces towards the LED light source.
- The side of the goboholder with the teeth faces towards the front glass.

With the goboholder placed teeth down on a clean surface and the gobo retaining spring facing upwards as shown in Figure 18, gobos in the ERA 600 Performance must be installed as follows:

- The shiny side must face upwards towards the spring in the goboholder. The white side must face downwards.
- Images or text on gobos must appear correctly (and not flipped left to right) when looking down at the goboholder from the side with the spring.
- The textured side of textured glass gobos must face upwards. The flat side of the gobo must face downwards so that the gobo sits flat in the goboholder.

Gobo alignment

See Figure 18. Note the position of the alignment marks (arrowed) on goboholders and gobos. Install gobos with the alignment marks next to each other.



Figure 18: Gobo alignment marks

Gobo replacement procedure

Avoid getting grease from your fingers or dirt onto gobos. Hold gobos by their edges only. Wear nitrile cleanroom gloves when handling gobos.

To replace a gobo in a goboholder:

1. See Figure 19. Place the goboholder on a clean surface with the shiny side of the gobo facing upwards. Note the position of the bend (arrowed) in the end of the gobo retaining spring. Using a plastic lever to avoid scratching the gobo, lever the end of the retaining spring out of the groove in the goboholder and lift the retaining spring out of the goboholder.

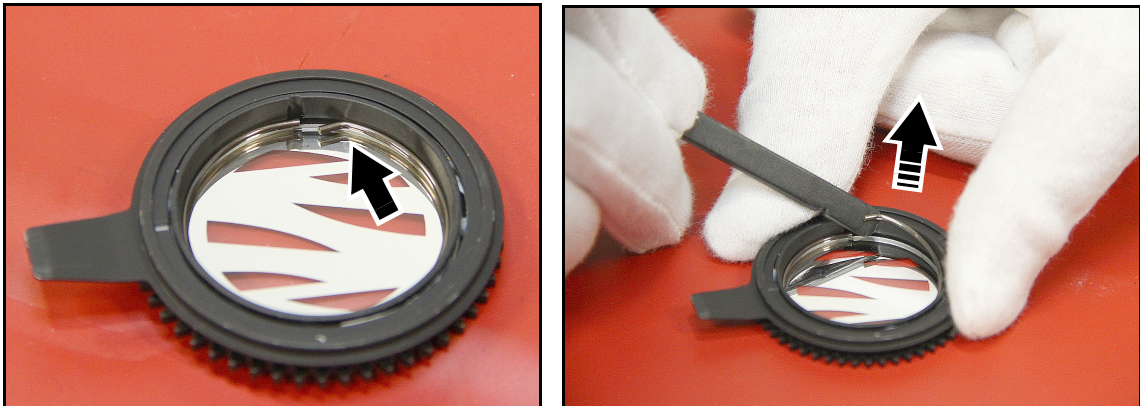

Figure 19: Removing a gobo from a goboholder

2. Turn the goboholder teeth side up and let the gobo fall out of the holder onto a clean, soft surface. Put the goboholder on the surface teeth side down again.
3. Holding the new gobo by its edges, insert it into the goboholder with the alignment marks on gobo and goboholder oriented correctly and with the shiny side facing upwards (see Figure 18). Check that the gobo is fully seated in the holder.
4. Insert the retaining spring into the goboholder and press it into its groove in the goboholder. Check that the spring is pressed as flat as possible against the gobo and that the gobo is held securely in the goboholder.
5. Reinstall the goboholder in the gobo wheel using the section “Replacing a rotating gobo” on page 19 as a guide.
6. When service work is finished, reinstall the head covers as described using the section “Opening the head for access” on page 18 as a guide.

Using the fixture

Before using the fixture, download and read the latest version of the ERA 600 Performance User Guide from the ERA 600 Performance area of the Martin website at www.martin.com. The User Guide contains details of:

- The effects available in the fixture.
- The control options available using DMX and/or RDM.
- The setup, monitoring and control options available using the onboard control and display panel.
- Software service functions.

Applying power



Warning! Before applying power to the fixture:

- **Read the safety information section of this manual starting on page 4.**
- **Read “Connecting to power” on page 14.**
- **Check that the installation is safe and secure.**
- **Check that the base is fastened securely so that the torque reaction when the head moves will not cause the base to move.**
- **Check that the head tilt lock is released (see “Tilt lock” on page 9).**
- **Be prepared for the fixture to light up suddenly. Check that no-one is looking at the fixture from close range.**
- **Be prepared for the head to move suddenly. Check that there will be no risk of collision with persons or objects.**

The ERA 600 Performance does not have an On/Off switch. To apply power to the fixture, apply power to the power input cable. Neutrik powerCON TRUE1 connectors also support hot-plugging.

Troubleshooting

Problem	Probable cause(s)	Remedy
One or more of the fixtures is completely dead.	No power to fixture.	Check that power is switched on and cables are plugged in.
	Fuse blown or internal fault.	Contact Martin Service or authorized service partner. Do not remove base or yoke covers, attempt to replace a fuse or carry out any repairs or service that are not described in this Safety and Installation Manual unless you have both authorization from Martin and official Martin service documentation.
Fixtures reset correctly but respond erratically or not at all to the controller.	Bad data link.	Inspect connections and cables. Correct poor connections. Repair or replace damaged cables.
	Data link not terminated.	Insert DMX termination plug in data output socket of the last ERA 600 Performance on the data link.
	Incorrect addressing of fixtures.	Check fixture address and protocol settings.
	One of the fixtures is defective and is disturbing data transmission on the link.	Unplug the XLR in and out connectors and connect them directly together to bypass one fixture at a time until normal operation is regained. Have the fixture serviced by a qualified technician.
Timeout error after fixture reset.	Effect requires mechanical adjustment.	Check fixture's stored error messages for more information. Contact Martin Service or authorized Martin service partner.
Mechanical effect loses position.	Mechanical train requires cleaning, adjustment, or lubrication.	Check fixture's stored error messages for more information. Contact Martin Service or authorized Martin service partner.
Light output cuts out intermittently.	Fixture is too hot.	Check fixture's stored error messages for more information. Allow fixture to cool. Clean fixture. Reduce ambient temperature.

Table 2: Troubleshooting

Specifications

Physical

Length (head)	544 mm (21.5 in.)
Width (base)	290 mm (11.4 in.)
Length (base)	416 mm (16.4 in.)
Width (across yoke)	390 mm (15.4 in.)
Height (head straight up)	734 mm (28.9 in.)
Height (maximum)	745 mm (29.4 in.)
Minimum center-to-center distance in side-by-side installation	660 mm (26.0 in.)
Weight	30.0 kg (66.1 lbs)

Dynamic Effects

Electronic 'shutter' effect	Strobe effect, pulse effects, instant open and blackout
Electronic dimming	0 - 100%, four dimming curve options
Color mixing	CMY, independently variable 0-100%
Color temperature control	Variable 6500 - 2700 K
Color wheel	7 color filters plus open
Rotating gobo wheel	7 gobos plus open, wheel rotation, gobo rotation, indexing and shake
Static gobo wheel	8 gobos plus open, wheel indexing, rotation and shake
Gobo animation	Animation wheel, indexing, continuous rotation with variable speed and direction
Iris	0-100%
Zoom	Motorized
Focus	Motorized
Framing	Rotatable framing module, +/-60°, with 4 individually controllable full framing blades with variable angle and position
Prism	2 rotating/indexing prisms (4-facet circular and 6-facet linear)
Frost	Soft frost effect
Pan	540°, coarse & fine control and speed
Tilt	260°, coarse & fine control and speed

Control and Programming

Control options	DMX
16-bit control	Dimming, CMY, CTO, pan and tilt
Setting and addressing	Control panel with backlit LCD display
DMX channels	41
DMX compliance	USITT DMX512/1990
RDM compliance	ANSI/ESTA E1.20
Transceiver	Opto-isolated RS-485

Optics

Front lens diameter	120 mm (4.75 in.)
Zoom range	6° - 45° (1:7.5)
Light source	550 W LED engine
Minimum LED lifetime	20 000 hours (to >70% luminous output)*

*Figure obtained under manufacturer's test conditions

Photometric Data

Light engine luminous output	37 000 lumens
Fixture luminous output	19 000 lumens
CCT (Calibrated Color Temperature)	6500 K (+/-250K)
CRI (Color Rendering Index)	>70
LED refresh rate	3600 Hz

Construction

Housing	High-impact flame-retardant thermoplastic
Color	Black
Protection rating	IP20

Gobos

External diameter	23.0 mm +0 / -0.2 mm (0.906 in. +0 / -0.008 in.)
Maximum image diameter	19 mm (0.75 in.)
Maximum gobo thickness	3.5 mm (0.14 in.)
Material	Borofloat 33
Coating	Heavy matted aluminum

Installation

Mounting points	2 pairs of 1/4-turn points for 106 mm (4.17 in.) center-to-center omega brackets
Location	Dry location only, must be fastened to surface or structure
Orientation	Any
Minimum distance to combustible materials	0.2 m (8 in.)
Minimum distance to illuminated surfaces	2.0 m (6.6 ft.)

Connections

AC mains power input	Neutrik TRUE1 socket, accepts TRUE1 NAC3FX-W (TOP) connector
AC mains power throughput	Neutrik TRUE1 socket, accepts TRUE1 NAC3MX-W (TOP) connector
DMX and RDM data in/out	5-pin locking XLR

Electrical

AC power	100-240 VAC (nominal), 50/60 Hz
Power supply unit	Auto-ranging electronic switch mode
Maximum total power consumption	856 W
Power consumption, all effects static, zero light output	64 W
Half-cycle RMS inrush current at 230 V, 50 Hz	21.8 A
Recommended MCB (Miniature Circuit Breaker) per IEC 60898/UL489/CSA C22.2 No. 5	Type D

Typical Power and Current



120 V, 60 Hz	6.5 A, 778 W, PF 0.994
230 V, 50 Hz	3.2 A, 760 W, PF 0.967

Figures are typical, not maximum. Measurements made at nominal voltage with all LEDs at full intensity. Allow for a deviation of +/- 10%. PF = power factor

Thermal

Cooling	Forced air (temperature-regulated, low noise)
Maximum surface temperature, steady state, at Ta 40° C	75° C (167° F)
Maximum ambient temperature (Ta max.)	40° C (104° F)
Minimum ambient temperature (Ta min.)	5° C (41° F)
Maximum total heat dissipation (calculated, +/- 10%)	2920 BTU/hr.

Approvals

	Global CB Certification/IECEE	IEC 60598-2-17 (IEC 60598-1)
	EU safety	EN 60598-2-17 (EN 60598-1), EN 62471, EN62493
	EU EMC	EN 55015, EN 55032, EN 55035, EN 61000-3-2, EN 61000-3-3, EN 61547
	US safety	UL 1573
	US EMC	FCC Part 15 Class B
	Canadian safety	CSA C22.2 No. 166
	Canadian EMC	ICES-3 (B) / NMB-3 (B); ICES-5 (B) / NMB-5 (B)
	Australia/NZ	RCM

Included Items

Two omega brackets with 1/4 turn fasteners for rigging clamp attachment

Accessories

Power input cables

Power Input Cable, H07RN-F, 2.5 mm ² , 14 AWG, bare ends to TRUE1 NAC3FX-W (female), 1.5 m (4.9 ft.)	P/N 91611797
Power Input Cable, H07RN-F, 2.5 mm ² , 14 AWG, bare ends to TRUE1 NAC3FX-W (female), 5 m (16.4 ft.)	P/N 91611786

- Power Input Cable, SJOOW, 12 AWG, bare ends to TRUE1 NAC3FX-W (female), 1.5 m (4.9 ft.) P/N 91610173
- Power Input Cable, SJOOW, 12 AWG, bare ends to TRUE1 NAC3FX-W (female), 5 m (16.4 ft.) P/N 91610174

Power relay cables, 16 A

- Power Relay Cable, H07RN-F, 2.5 mm², TRUE1 to TRUE1, 0.45 m (1.5 ft.) P/N 91611784
- Power Relay Cable, H07RN-F, 2.5 mm², TRUE1 to TRUE1, 1.2 m (3.9 ft.) P/N 91611785
- Power Relay Cable, H07RN-F, 2.5 mm², TRUE1 to TRUE1, 2.5 m (8.2 ft.) P/N 91611796
- Power Relay Cable, SJOOW, 12 AWG, TRUE1 to TRUE1, 0.45 m (1.5 ft.) P/N 91610170
- Power Relay Cable, SJOOW, 12 AWG, TRUE1 to TRUE1, 1.2 m (3.9 ft.) P/N 91610171
- Power Relay Cable, SJOOW, 12 AWG, TRUE1 to TRUE1, 2.5 m (8.2 ft.) P/N 91610172

Power connectors

- Cable Connector, Neutrik powerCON TRUE1 NAC3FX-W TOP (female) P/N 91611789HU
- Cable Connector, Neutrik powerCON TRUE1 NAC3MX-W TOP (male) P/N 91611788HU

Installation hardware

- Half-coupler Clamp P/N 91602005
- Safety Cable, SWL 60 kg, BGV C1 / DGUV 17, black P/N 91604006
- Safety Cable, SWL 60 kg, BGV C1 / DGUV 17, silver P/N 91604007

Related Items

- Martin® Companion software suite (incl. firmware uploader) Free download from www.martin.com
- Martin® Companion Cable USB/DMX hardware interface P/N 91616091
- Martin® RDM 5.5 Splitter P/N 90758150

Ordering Information

- ERA 600 Performance in cardboard box P/N 9025122049
- ERA 600 Performance (White) in cardboard box P/N 9025122050
- Flightcase, two unit, holds 2 x ERA 600 Performance P/N 91512205

Specifications subject to change without notice. For the latest product specifications, including photometric data, see www.martin.com

Photobiological Safety Warning

The label shown on the right is displayed on this product. If it becomes difficult or impossible to read, it must be replaced using the illustration on the right to reproduce a new label printed in black on a yellow background.

FCC Compliance

This equipment has been tested and found to comply with the limits for a Class B digital device, pursuant to part 15 of the FCC Rules. These limits are designed to provide reasonable protection against harmful interference when the equipment is operated in a commercial environment. This equipment generates, uses and can radiate radio frequency energy and, if not installed and used in accordance with the instructions, may cause harmful interference to radio communications. Operation of this equipment in a residential area is likely to cause harmful interference, in which case the user will be required to correct the interference at his own expense.

Supplier's Declaration of Conformity

Harman Professional, Inc. have issued an FCC Supplier's Declaration of Conformity for this product. The Declaration of Conformity is available for download from the ERA 600 Performance area of the Martin website at www.martin.com

Canadian Interference-Causing Equipment Regulations - Règlement sur le Matériel Brouilleur du Canada

This Class B digital apparatus meets all requirements of the Canadian Interference-Causing Equipment Regulations. *Cet appareil numérique de la classe B respecte toutes les exigences du Règlement sur le Matériel Brouilleur du Canada.*
 CAN ICES-3 (B) / NMB-3 (B); CAN ICES-5 (B) / NMB-5 (B)

EU Declaration of Conformity

An EU Declaration of Conformity covering this product is available for download from the ERA 600 Performance area of the Martin website at www.martin.com.

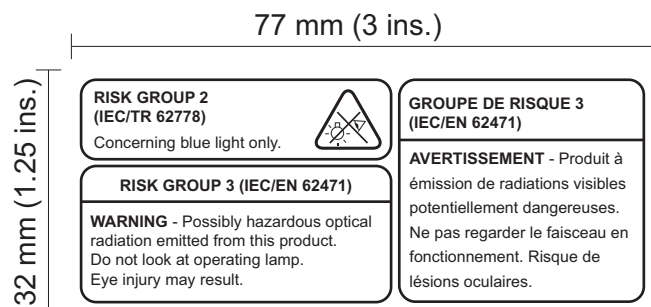

Intellectual Property Rights

Martin® ERA 600 products are covered by one or more of these patents:

CN101430080; CN102713425; CNZL200810128720.0; CNZL200810128776.6; CNZL200810144668.8; CNZL201080025103.3; CNZL201180014884.0; CNZL201380004370.6; CZ17567; EP2058586; EP2113714; EP2117284; EP2136136; EP2326150; EP2443381; EP2536974; EP2550686; EP2828577; EP2881650; US6971770; US7,703,948; US7,789,543; US7,905,630; US7,942,535; US7,990,673; US7222997; US7498756; US8,449,141; US8,708,535; US8,770,762; US9217551; US9217559;

and/or one or more of these patent applications:

CN104696882; CN104698579; CN104976548; CN105402641; CN201410740291.8; CN201410742572; DKPA201700088; EP17167067.2; EP2091302; EP2881651; EP2881652; EP2881653; EP2927579; EP2995852; US2015/0285483; US20150159827; US20150159828; US20150159830; US20160069540; US20160102850;

and/or one or more other intellectual property rights, including one or more intellectual property rights listed on www.martin.com/ipr



Disposing of this product

Martin products are supplied in compliance with Directive 2012/19/EC of the European Parliament and of the Council of the European Union on WEEE (Waste Electrical and Electronic Equipment), where applicable.

Help preserve the environment! Ensure that this product is recycled at the end of its life. Your supplier can give details of local arrangements for the disposal of Martin products.



