



Quam

8C10PAOT

8" Moisture Resistant Loudspeaker

02

LOUDSPEAKERS, INDIVIDUAL

0204 - MOISTURE RESISTANT LOUDSPEAKERS, INDIVIDUAL

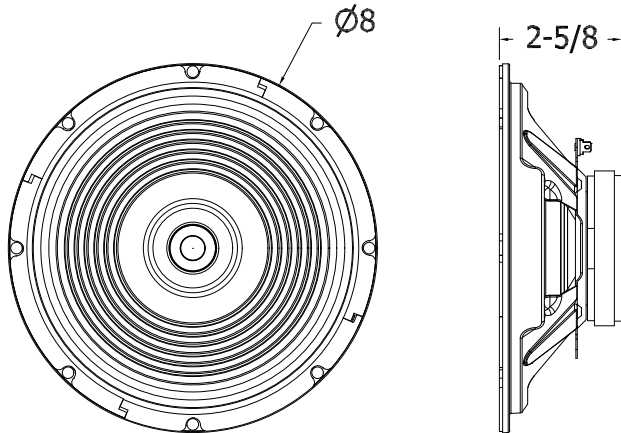

GENERAL DESCRIPTION

The Quam 8C10PAOT is an 8" frame, 8 Ohm loudspeaker with phenolic resin impregnated cone. Finish: Black baked epoxy hybrid.

INTENDED USE

Moisture resistant, replacement loudspeaker or combined with recommended Quam components to form a complete loudspeaker system; outdoor or indoor environment.

Program Material: Signal tones, voice and music

SYSTEM COMPONENTS

N/A

RECOMMENDED ADDITIONAL QUAM COMPONENTS

Refer to Section 0104.6 - Customer Specified Assembly or individual components listed below:

- 0502- Transformers
- 0301- Baffles, Round -or-
- 0302- Baffles, Square
- 0401.1- Flush Mounted Back Boxes, Round -or-
- 0401.2 Flush Mounted Back Boxes, Square
- 0402- Loudspeaker Mounting Devices

AUDIO SPECIFICATIONS

Speaker Size:	8" frame
Average Sensitivity:	94 dB SPL, 1W/ 1M
Power Rating:	20W RMS, EIA 426A Standard
Calculated Output:	105dB SPL, 10W/ 1M
Magnet Type, Weight	BeFe Ceramic, 10 oz. Nominal
Frequency Response:	80Hz - 8 kHz EIA 462A Standard
Nominal :	100° Included Angle,
Coverage Angle:	-6 dB / 2 kHz, Half space
Mounting	8x 1/4" holes spaced 45° apart on 7-5/8" circle
Audio Connection:	0.205" Spade lug

Recommended construction sequences, installation instructions and A&E Specifications are available in various formats on the Quam Architects' and Engineers' Resources CD or on the web at: www.quamspeakers.com

Quam-Nichols Company

234 East Marquette Road, Chicago, IL 60637
 Phone: (800) NEED NOW Fax: (888) NEED NOW
 (800) 633 - 3669 (888) 633 - 3669
 E-Mail: neednow@qnc.com www.quamspeakers.com

