

General Description

The Rane MS 1a Mic Stage preamplifier provides the answer when you need just one microphone input in an otherwise line-level world. Give us a call to go from either a dynamic, condenser or electret microphone to a line-level input with a minimum of noise, distortion, cost and hassle.

The MS 1a provides 48 V switchable Phantom Power with indicator LED, continuous rotary Gain trim between 21.5 dB and 66 dB, Signal/Overload LED, and XLR balanced Input & Output connectors. A Polarity switch and high-current cross-coupled output line driver round out the features.

The MS 1a utilizes one of the finest ultra low noise amplifier designs available. Featuring a true differential input with high common-mode rejection, use of the MS 1a guarantees performance usually found only in mixing consoles costing thousands of times as much. Of course, for all of that extra money you receive a proportional increase in KPSI (knobs per square inch).

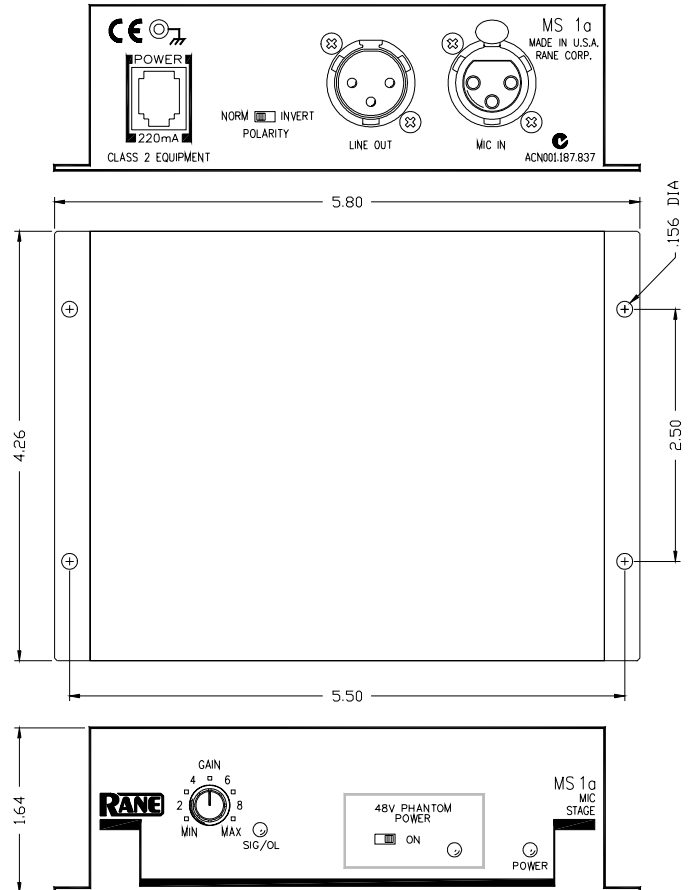

Features

- Gain Control
- Signal and Overload Indicators
- Polarity Switch
- Switchable 48 V Phantom Power
- Ultra Low Noise Design
- True Differential Input
- Cross-Coupled Line Driver
- UL/CSA/CE and 100/120/230 VAC Remote Power Supply



Features and Specifications

| Parameter | Specification | Limit | Units | Conditions/Comments |
|------------------------------|-------------------------------|-------|--------|--|
| Input Impedance | 10k | 1% | ohms | Balanced 5k + 5k |
| Gain Range | 21.5 to 66 | typ. | dB | |
| Phantom Power | +48 | 4% | volts | 10 mA max. |
|Impedance | 6.81k | 1% | ohms | Each leg |
|Load Regulation | 0.1 | typ. | % | 0 to 14 mA |
|RMS CM Noise | .003 | typ. | % | % of Vout (10 to 10k Hz) |
| Max. Input Level | +4.5/-34 | min. | dBu | Gain 21.5/60, balanced output |
|Max. Input Level | -1.5/-40 | min. | dBu | Gain 21.5/60, unbalanced output |
| Equivalent Input Noise | -129 | 1 | dBu | 20 kHz BW, Rs=150 ohms, Gain = 60 dB |
| Signal to Noise Ratio | 96 | 1 | dB | 20 kHz BW, Rs=150 ohms, Gain = 21.5 dB, re 4 dBu |
| Dynamic Range | 95/118 | typ. | dB | Gain 60/21.5 |
| CMRR | 80 | typ. | dB | Rs=150 ohms, 1 kHz |
| Frequency Response | | | | |
|Gain 60 dB | 55 to 100k | typ. | Hz | +0, -3dB |
|Gain 21.5 dB | 40 to 100k | typ. | Hz | +0, -3db |
| THD+Noise (gain 60 dB) | .007 (Output=+20 dBu) | typ. | % | 20 to 20k Hz, 80 kHz BW, Rl=10k ohms |
| THD+Noise (gain 21.5 dB) | .001 (Output=+20 dBu) | typ. | % | 20 to 20k Hz, 80 kHz BW, Rl=10k ohms |
| Line Driver | Active Cross-coupled | | | Gain 5.2/6 dB typ. unbalanced/balanced |
| Max. Output Level | +20/+26 | min. | dBu | Unbalanced/balanced, 2k ohm load |
| Output Impedance | 50 | 1% | ohms | Each Leg |
| Signal Indicator | 2/8 | typ. | dBu | Unbalanced/balanced output, Green LED |
| Overload Indicator | 14/20 | typ. | dBu | Unbalanced/balanced output, Amber LED |
| Output Cable Length | 300 | typ. | meters | Belden 8451 or equivalent |
| Unit: Agency Listing | | | | |
|120 VAC model | Class 2 Equipment UL & CSA | | | National Electrical Code Exempt Class 2 equipment |
|230 VAC model | CE-EMC CE-Safety | | | EMC directive 89/336/EEC Exempt per Art. 1, LVD 73/23/EEC |
| Power Supply: Agency Listing | | | | Class 2 Equipment |
|120 VAC model | UL CSA | | | File no. E88261 File no. LR58948 |
|230 VAC model | CE-EMC CE-Safety | | | EMC directive 89/336/EEC LV directive 73/23/EEC |
|100 VAC model | Built to JIS | | | Japan only |
| Power Supply Input | 18 VAC w/center tap | 10% | Vrms | Rane RS 1 supplied |
| Max Current Consumption | 220 | | mA | |
| Unit Size | 1.65" H x 5.1" W x 4.25" D | | | (4.2 cm x 13 cm x 10.8 cm) |
|Weight | 1 lb | | | (0.45 kg) |
| Shipping Size | 3.6" H x 11.75" W x 7.2" D | | | (9.5 cm x 30 cm x 18 cm) |
|Weight | 4 lb | | | (1.8 kg) |

Block Diagram

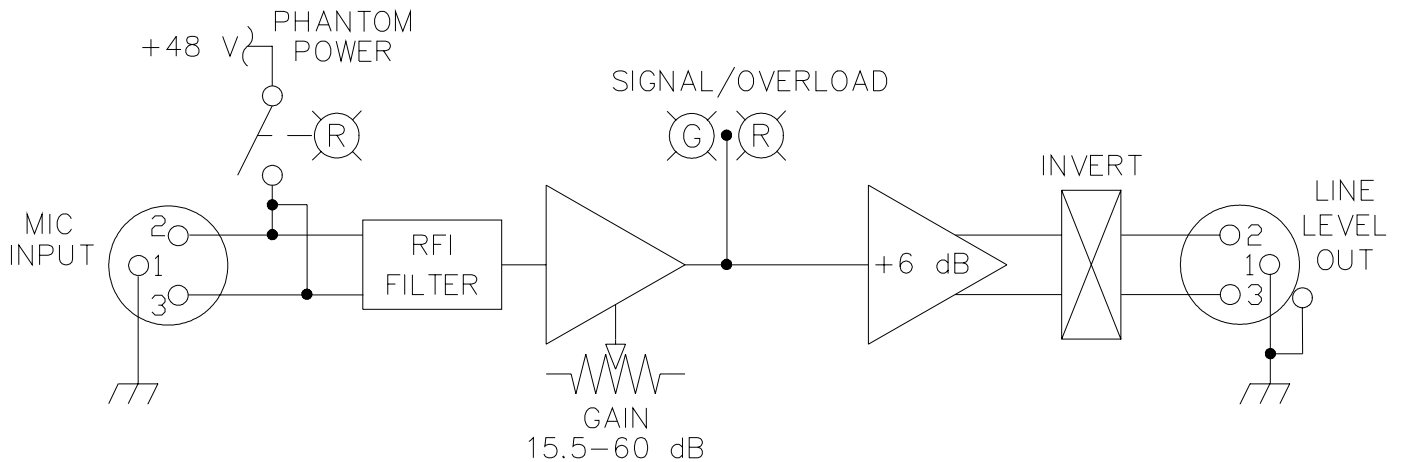

Application Information

Uses and applications for the MS 1a should be obvious. But then again, its obvious to us our taxes are too high and nothing is being done about that. With this in mind, perhaps a few words on using the MS 1a might not be wasted.

BALANCED USE

The MS 1a provides a true cross-coupled balanced output. This is equivalent to an electronic simulation of a transformer output. Rane follows the AES standard of pin 2 = hot.

When running a long cable back to the mixer, run a *line-level* balanced line rather than a mic-level line. The compact MS 1a can mount closer to the microphone, provide a local volume control (or not, just pull the knob off), while the stronger signal minimizes RF and hum irritations.

UNBALANCED USE

Balanced use is recommended to minimize noise. When you must drive an unbalanced device with the MS 1a's balanced output, connect pin 2 to the "+" or "hot" lead, and tie pin 3 and ground together at the shield.

MIXING

The MS 1a is designed to fill the need for adding a microphone channel to line-level mixers, such as the Rane SM 26B or SM 82. Many installations using either of these products invariably wind up with one unused input that would do the job perfectly if only it could operate at mic-level. In rides the MS 1a to the rescue.

DIGITAL RECORDING AND SAMPLING

Another handy use for the MS 1a is in recording applications. Many popular products do not have a high enough quality mic preamp to suit the resolution of the digital processing electronics. Such irony. Using the ultra low noise MS 1a to bring the mic inputs up to extremely high quality line-level is an easy and affordable solution for this dilemma. No garbage in; no garbage out. *Clippity-clop; clippity-clop.*

MICROPHONE TYPES

The available gain range of the MS 1a allows the use of virtually any type of microphone. True 48V phantom power guarantees the MS 1a works with every microphone. The better the mic, the better the MS 1a sounds.

Ah, the sound of the thundering hoofs is deafening.

Architectural Specifications

The microphone preamplifier shall be a single channel stand-alone unit with remote power supply. The power supply shall be U.L. listed, C.S.A. certified, and CE certified. The input and output shall be fitted with XLR connectors. A polarity inverting switch shall be included. Phantom power shall be provided in compliance with DIN 45596 & IEC 268-15 and be controlled by a slide switch with an LED indicator. A gain control shall be provided with 21.5-66 dB adjustment range. Power, system signal and overload indicators shall be provided. High current cross-coupled active output line driver shall be standard, as well as input RFI filter protection.

The unit shall be a Rane MS 1a Microphone Stage.

CHASSIS GROUNDING

Units with outboard power supplies do not ground the chassis through the line cord. Make sure that these units are grounded either to another chassis which is earth grounded, or directly to the grounding screw on an AC outlet cover by means of a wire connected to a screw on the chassis with a star washer to guarantee proper contact.

Please refer to RaneNote 110, "Sound System Interconnection" (supplied in your manual and available on request separately) for further information on system grounding.