

DSP-CONTROLLED AUDIO SYSTEMS PROMISE space savings, rapid reconfiguration, and tamper-proof installations. DSP architecture from Symetrix delivers more. We take DSP control to the next level with the introduction of Audio Workplace, an evolutionary combination of hardware and software. Each element of Audio Workplace is designed to enhance performance and increase flexibility in systems of any size. The 9022 2x2 DSP Engine is the first hardware component developed for this system.

The true power behind this system comes from the Symetrix Audio Workplace software that controls it. Unlike many similar DSP systems, Audio Workplace offers a completely user-configurable signal flow. Starting in its configuration editor, the installer can “drag and drop” each processing block in the audio signal path. These blocks feature 31-band graphic or 10-band parametric EQ, high- and low-pass filtering, delay, and multiband comp/limiting functions. They can be placed anywhere along the signal chain and easily moved for changing installation needs. A pink noise generator is also included for testing and sound masking applications.

Though easy to use, this system hides a sophisticated dynamics processing engine. Each processing block comes loaded with additional control options. From the compressor’s unique split band mode to the delay’s fine resolution for driver alignment, Audio Workplace offers comprehensive audio control.

Once programmed, the 9022 operates independently, and it retains all programming during AC

brownouts or power loss. Nonvolatile flash RAM stores all settings. Its RS-232 port also includes a fail-safe relay bypass. In the unlikely event that one unit in a daisy chain of 9022s fails, control data will bypass this port, maintaining the integrity of the system.

The processing circuitry controlled by Audio Workplace resides within the 9022’s 1U-high chassis. A streamlined front panel display features system status LEDs to indicate selected preset, clipping, signal presence, bypass, communications and power. Audio Workplace control data streams through front or rear panel RS-232 ports, leaving the 9022’s chassis tamper-proof. These ports also give installers a connection for on-site upgrading of the unit’s DSP code. Audio signal I/O is via rear panel XLR or Euroblock terminal connectors. Additional connections include Euroblock connectors for remote preset selection and RS-232 ports for daisy-chaining of up to 125 separate 9022 processors.

Symetrix Audio Workplace and the 9022 2x2 DSP Engine: The evolution of audio architecture for DSP-controlled installations. •

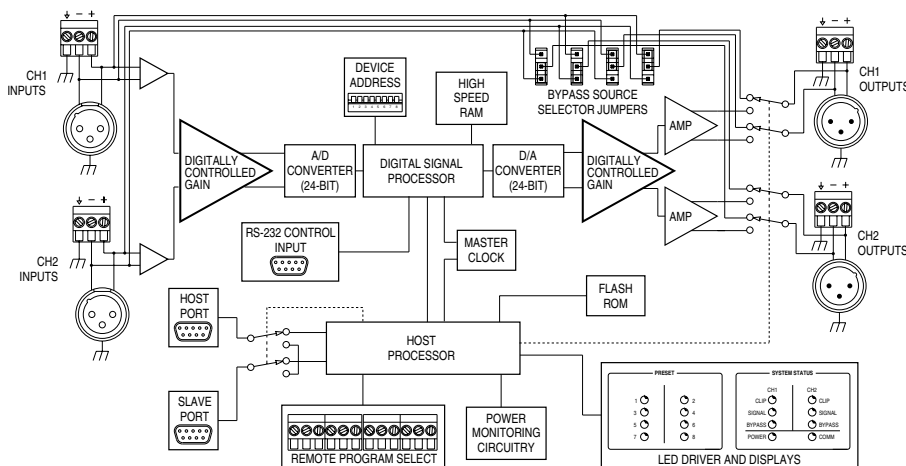

APPLICATIONS

- Houses of Worship
- Stadiums
- Schools & Auditoriums
- Casinos
- Hotel & Convention Facilities

FEATURES

- Audio Workplace™ DSP-control
- Graphic and Parametric EQ, Hi/Low Pass Filter Set, Room Delay & Multiband Comp/Limiter
- 24-bit A/D - D/A converters
- On-site upgradable DSP code
- Front & rear panel RS-232 connections for tamper-proof operation
- Remote preset recall via contact closures
- UL-listed PS-3 power supply

9022

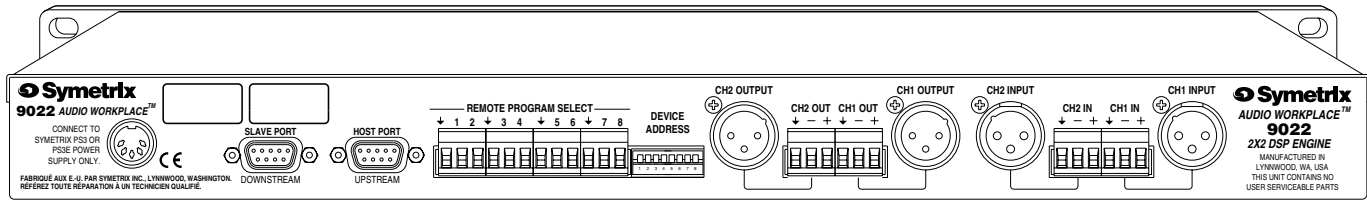

SPECIFICATIONS

Specifications subject to change without notice.

Analog to Digital Conversion

Dynamic Range	>114 dBFS, A-weighted
THD+Noise	< .002% THD @ -1dBFS, 1kHz, input attenuators set to unity gain
Input Impedance	>20k balanced
Maximum Input Level	25dBu balanced
Minimum Recommended Nominal Input Level	-10dBu balanced, 0dBFS at maximum gain
Minimum CMR	40dB at 60Hz

Digital to Analog Conversion

Dynamic Range	>112 dBFS, A-weighted
THD+Noise	<.003% at -1 dBFS, 1kHz, output attenuators set to unity gain
Output Impedance	300 Ohms balanced

Performance Data

Frequency Response	20 Hz to 20 kHz, ±0.5 dB
Sample Rate	48 kHz
Converter Types	Delta-Sigma
Conversion Method	24-bit
Filter Algorithms	Power normalized lattice structure
Pink Noise	>6 minute cycle period
Number of Stored Programs	8
Maximum Number of Units on a Single Daisy Chain	125
Serial Baud Rate	19.2k or 38.4k, 8-bit, no parity

Physical

Size (hwd)	1.75 x 19 x 6 inches, 4.44 x 48.26 x 15.24 centimeters
Weight	4.4 lbs (1.99 kg) net

Electrical

Power requirements	115V AC nominal, 105 to 125V AC, 50 to 60Hz, 20 watts 230V AC nominal, 205 to 253V AC, 50 to 60Hz, 20 watts
--------------------	--

9022 ARCHITECTS AND ENGINEERS SPECIFICATIONS

The digital signal processor (Processor) shall have two inputs and two outputs. There shall be no user-accessible (front panel) controls. The Processor shall perform all signal processing functions in the digital domain utilizing 24-bit digital wordlengths. Analog-to-digital and digital-to-analog conversion shall use 24-bit delta-sigma converters.

The Processor shall provide the following signal processing functions: high-pass filters, low-pass filters, equalization (either graphic or parametric), signal delay, and single- and dual-band compression/limiting. The Processor shall also provide pink noise for testing and sound masking purposes.

All signal processing functions shall be controllable by a suitable graphical interface computer program. The computer control program shall allow each channel of the Processor to be configured to use the aforementioned signal processing functions via a drag-and-drop user interface. Each channel shall have eight locations for signal processing blocks. It shall be possible to interconnect the two channels of the Processor so that one input drives both outputs.

Communication with the Processor shall take place via RS-232 serial protocol. The Processor shall be capable of storing 8 preset configurations in its own memory

and recalling via a contact closure arrangement. The system status shall be indicated on the front panel. The system programming port shall be accessible from the front panel. Up to 125 multiple Processors shall be capable of being chain-connected together while maintaining their addressability.

All audio connections shall be balanced and accessible via XLR connectors and bare wires. RS-232 connections shall utilize DB-9 female connectors. There shall be no batteries within the Processor.

The digital signal processor shall be the Symetrix 9022 2x2 DSP Engine.

9022