

L45-21

Shown with door sliding into stowed position.

L45-21

Shown with door in locked position and optional laminate top.

L45-21 Rolling Slope-front Cabinet

Cabinet Includes:

- **Stowing Front Door with Lock:** Flush door opens from top and slides into base for storage.
- **Recessed Rear Door with lock:** Short design features a 1RU opening for wire access.
- **Sloped Front with Fixed Mounting Rails:** Tapped 10-32
- **4 Twin-wheel Casters:** Allows easy rolling on carpets & floors
- **Front Cut-outs with Cover Plates:** Allows optional Decora-style devices to be installed and used without opening the cabinet.
- **Panel Mounting Hardware:** PilotPoint™ screws with captive washers.
- **Wrinkle Powder Epoxy Finish:** Choose Black (standard) or Network Grey (suffix -G).

Optional 1" Thick Laminate Top:

- Choose Cherry (L45-CT) or Graphite Gray (L45-GT).

Description

Model L45-21 slope-front rolling cabinet measures less than 27"H to fit under work surfaces providing rollout access to electronics when needed. Model features side handles, casters, a unique "stow-away" door, and two cutouts for external mounting of accessory switches or controls. Cabinet is 26.875"H (including casters).

Ergonomic design features 12RU of mounting space on a 15° slope for comfortable viewing of equipment while seated. The locking front door opens from the top and stores in the lower track area of the base. Stowing door design resolves the common problem of "swing-out" doors blocking equipment in neighboring work areas and avoids the potential of an open door below eye level being a safety hazard.

The recessed rear door includes a lock (keyed different than the front door) and is 1RU shorter than the opening to provide easy access for cords and cabling into the cabinet.

Model L45-21 also features Lowell's innovative cut-out design for easy field installation of externally accessible decora-style controls. Located above the front door are two cutouts with cover plates installed for optional installation of low voltage switches or devices. Externally accessible switches and equipment indicators provide functional convenience without opening/unlocking the cabinet which can be a positive security attribute.

Precision crafted cabinet is fully welded, 16-gauge steel construction with reinforcement at all load-bearing junctures to provide substantial strength-to-weight ratio. Twin wheel casters have a 125 lb load rating each (500 lbs. total) and are designed for smooth operation on carpets or floors. To facilitate natural heat dissipation and air circulation, Model L45-21 features vented sides, top and bottom vents on the front door and a 1RU opening below the rear door (used primarily for cable management).

A & E Specifications

The slope-front rolling cabinet shall be Lowell model L45-21. It shall measure 26.875"H x 25.5"D with casters. It shall include side handles, twin-wheel casters, a stowing front door with lock, short rear door with lock, and two front cutouts with cover plates for external installation of accessory switches or controls. The cabinet shall include fixed rails tapped 10-32 for mounting 12RU of 19"W equipment on a 15° slope. It shall be fully welded, 16-gauge steel construction with reinforcement at all load-bearing junctures. Casters shall have a 125 lb load rating each. Vents for natural heat dissipation shall be provided on the sides, front door, and under the rear door. Finish shall be powder epoxy in black or Network Grey.



L45-21

Rolling Slope-front 26.875"H Cabinet (page 2)

RACKS

Open Frame Floor

 Solid Side Floor & Desk

Wallmount Surface & Recessed

Panels & Accessories

Thermal & Wire Mngmt

Under Desk (rolling)

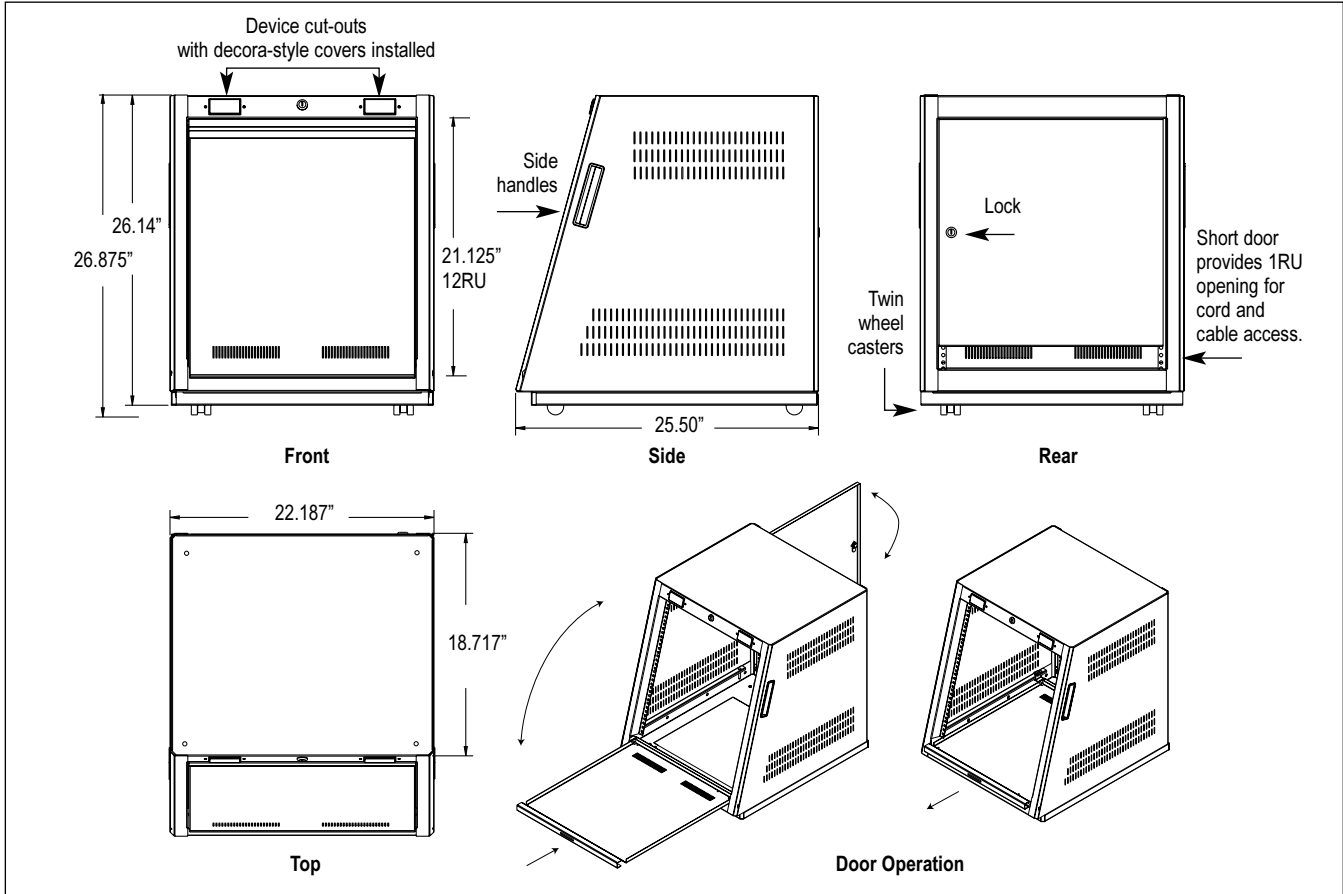

CABINET SPECIFICATIONS FOR L45-21

Cabinet Model	Panel Space*	Overall Height with casters	Overall Width	Overall Depth bottom / top	Fixed Rails Installed	Front Door	Rear Door	Decora Cut-outs w/cover plates	Casters Installed	Optional 1"H laminate top (order separately)
L45-21	21.125" (12RU)	26.875"	22.187"	25.5" / 18.717"	1pr.	stowing	L7-1919	2	4	L45-CT, L45-GT

*Racking depth in the 15° sloping cabinet varies from 17.1" to 20.3" in the top 9RU to 13.7", 7.2", and 1" respectively in the last 3 RU. See diagram below.

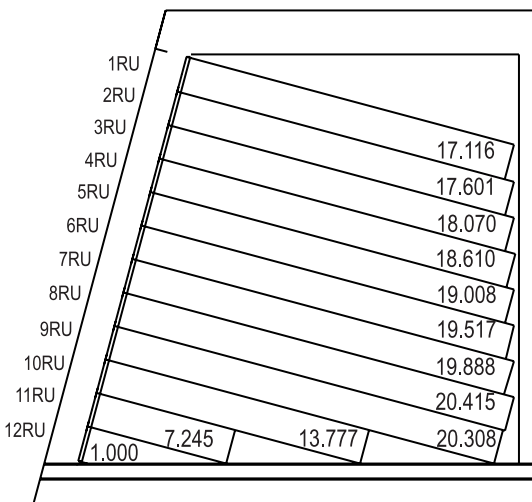

Maximum racking depth for each rack unit on 15° slope

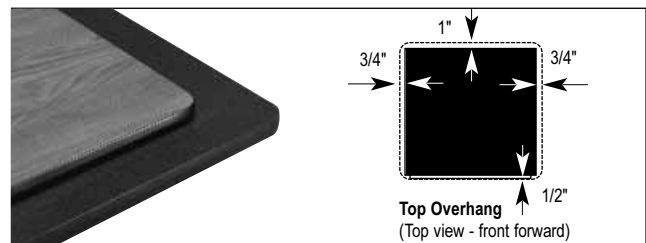

Optional Laminate Tops - 1" thick (order separately)
L45-CT is Cherry, L45-GT is Graphite Gray

Optional laminate top is ideal for applications where a more "furniture-grade" cabinet is desired. Top is laminate-covered particle board with rounded corners and rubber edge molding. Overall dimensions are 23.75"W x 20.25"D x 1"H for an overhang of .5" in the front, 1" in the rear and .75" on both sides. The top is offered with an attractive cherry wood (L45-CT) or graphite (L45-GT) laminate surface. Includes 10-32 T-nuts (installed) and mounts to tiny indents in the cabinet top using hardware included.