

### Features

- Separates and secures equipment in a single cabinet installation
- Frame mounts using NO panel mounting space.
- Installation typically does not disturb previously installed equipment.
- Accepts standard doors - choose solid, Plexiglas, or perforated styles.
- Top and bottom doors are keyed differently.

### Description

L46 Series is an architecturally appealing door system that solves the growing need for separating and securing equipment in a single cabinet installation. Attractive "boardroom quality" solution for dual-access security features a series of beveled edge frames that face mount to Lowell ganging racks, floor and sectional wall cabinets. Frames are ordered in the same panel space opening sizes as the cabinet and are equipped with threaded nutserts for mounting two doors with left or right swing. Door selection includes solid, Plexiglas, or perforated styles in sizes noted (order separately). For security, top and bottom doors are keyed differently. Top doors include the standard front door lockset (black); bottom doors include the same lockset as the rear door (chrome) and are suffixed with -RL for "rear-door lock". *If you prefer the top door to be keyed to match the rear, please suffix the top door with -RL and do not suffix the bottom door.*

The L46 Series steel frame is 1"D with vents and bevels to match the cabinet. The frame (and specified doors) will be factory installed when ordered with the cabinet or may be easily field installed without drilling or removing prewired equipment. The frame face mounts using four (4) 10-32 x 5/8" hex washer-head machine screws (included) to the top and bottom factory mounted nutserts on Lowell cabinets (typically used for mounting door hinges). The frame includes threaded nutserts to mount up to two of Lowell's standard 1"D doors (see page 2).

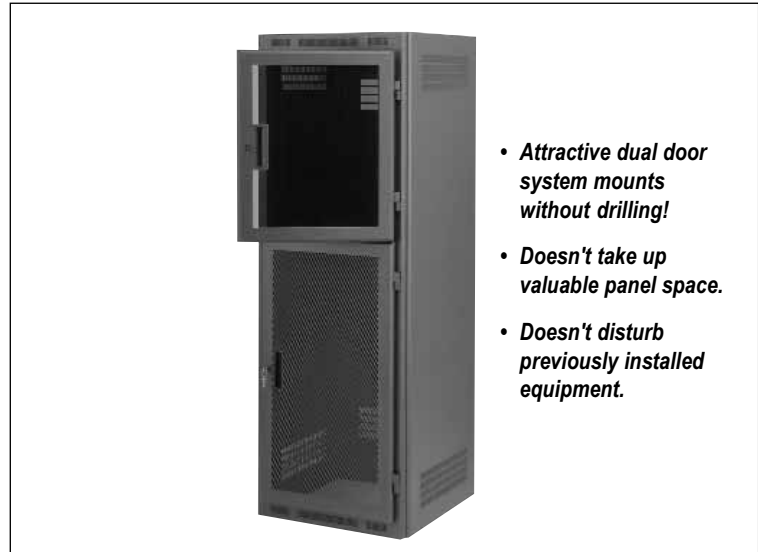

- **Attractive dual door system mounts without drilling!**
- **Doesn't take up valuable panel space.**
- **Doesn't disturb previously installed equipment.**

**Cabinet with dual door system.**

Model L260-61 cabinet shown with L46-61 frame, L2150-24P top door and L2150-36PF bottom door. Cabinet, frame, and doors are ordered separately but factory installed when ordered at the same time.

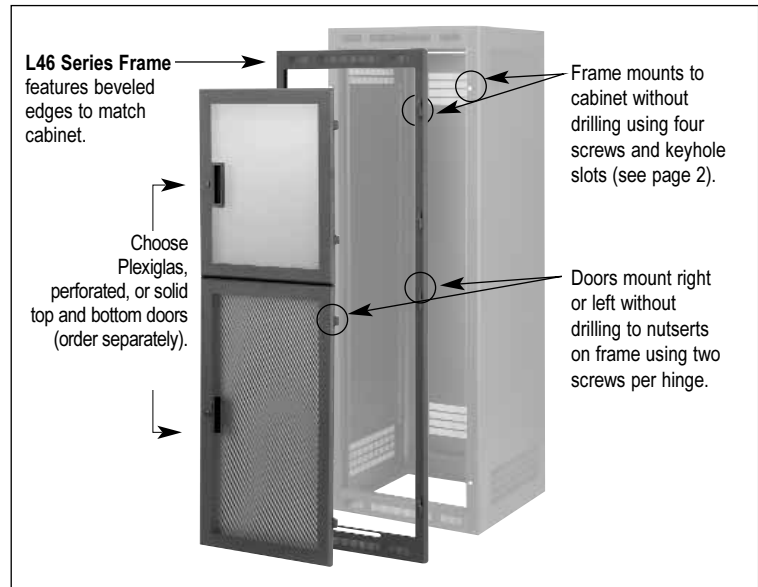

**L46 Series Frame** features beveled edges to match cabinet.

Frame mounts to cabinet without drilling using four screws and keyhole slots (see page 2).

Choose Plexiglas, perforated, or solid top and bottom doors (order separately).

Doors mount right or left without drilling to nutserts on frame using two screws per hinge.

Door (1"D) Frame	Mounts Rack Height	Top Door (20W x 1"D) (order separately)*	Top Door Panel Space	Bottom Door (20W x 1"D) (order separately)*	Bottom Door Panel Space	Mounts to Lowell Rack and Cabinet Models
L46-77	77.125" (44RU)	*L2150-36(-P)(-PF)	36.875" (21RU)	*L2150-42(-P)(-PF)-RL	40.375" (23RU)	L279-77, L278-77, L277-77, L275-77, L268-77, L267-77, L265-77, L262-77, L260-77
L46-70	70.125" (40RU)	*L2150-28(-P)(-PF)	28.125" (16RU)	*L2150-42(-P)(-PF)-RL	42.125" (24RU)	L279-70, L278-70, L277-70, L275-70, L268-70, L267-70, L265-70, L262-70, L260-70
L46-61	61.375" (35RU)	*L2150-24(-P)(-PF)	24.625" (14RU)	*L2150-36(-P)(-PF)-RL	36.875" (21RU)	L279-61, L278-61, L277-61, L275-61, L268-61, L267-61, L265-61, L262-61, L260-61, L253-61, L250-61
L46-42	42.125" (24RU)	*L2150-17(-P)(-PF)	17.625" (10RU)	*L2150-24(-P)(-PF)-RL	24.625" (14RU)	L277-42, L267-42, L265-42, L262-42, L260-42, L253-42, L250-42, L259-42(repl.)
L46-36	36.875" (21RU)	*L2150-12(-P)(-PF)	12.875" (7RU)	*L2150-24(-P)(-PF)-RL	24.625" (14RU)	L267-36, L265-36, L262-36, L260-36, L253-36, L250-36, L258-36(repl.), L259-36(repl.)

\*Standard door (without suffix) is solid steel. To order Plexiglas door suffix -P; to order perforated steel door suffix -PF. Additionally, bottom doors include a suffix -RL for rear-door lock. If you prefer the top door to be keyed to match the rear door, please suffix the top door with -RL instead.



## L46 Series



## Dual surface front door system for Lowell racks and cabinets

RACKS

Open Frame Floor

Solid Side Floor & Desk

Wallmount Surface & Recessed

Panels & Accessories

Thermal & Wire Mngmt

19W Door Accessories

### L46 Series dual door frame and doors (order separately) are factory mounted to the cabinet if ordered with the cabinet.

For applications, where the frame is field installed, simply mount the frame to the cabinet using four (4) 10-32 x 5/8" screws provided. Mount screws into the top two nutserts and bottom two nutserts as shown (back screw out slightly). Frame then mounts over screw heads using keyhole slots on rear of frame.

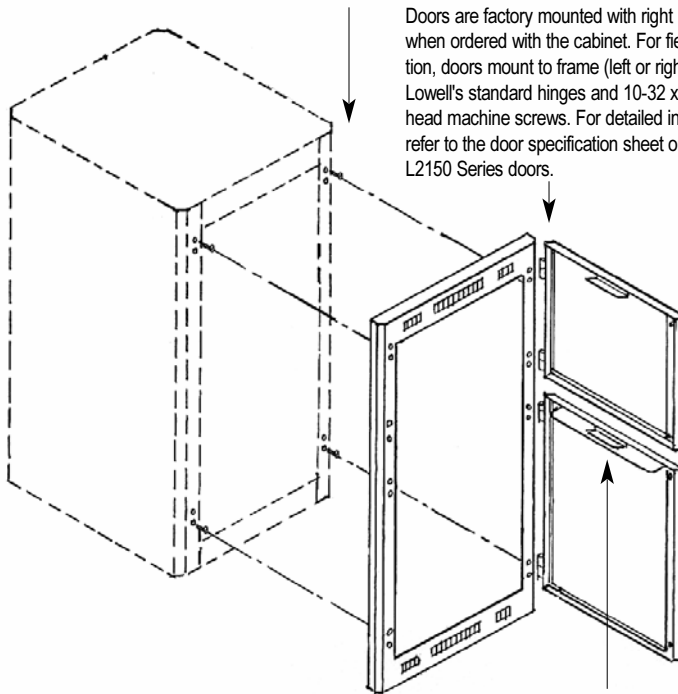

Doors are factory mounted with right hinging when ordered with the cabinet. For field installation, doors mount to frame (left or right) using Lowell's standard hinges and 10-32 x 1" socket-head machine screws. For detailed instructions, refer to the door specification sheet on Series L2150 Series doors.

#### Security bracket

(included with L46 Series frame) keeps contents in bottom section secure when the top door is open. Bracket projects in to the cabinet to within 1/4" of the mounting rails and is factory installed when the frame and doors are ordered with the cabinet. For field installation two 8-32 x .5" machine screws are provided.

### Surface Mount Doors (Order separately)

L46 Series frames mount Lowell's standard surface door Series L2150. Doors feature Lowell's innovative 45 degree bevel on all four sides, 180 degree open-swing access, and quick in-field change from right to left swing by simply moving the hinges. Specify solid, smoked Plexiglas (-P), or perforated steel (-PF) styles to meet your security, aesthetic, and ventilation needs. All styles surface mount and are precision formed from one piece of 16-gauge steel for torsional rigidity. The Plexiglas model also features a smoked plexiglas panel insert. Doors extend 1" from the L46 Series frame and include a comfortable flush handle insert, keylock, and two door hinges that install with two 10-32 x 1" socket-head machine screws each, for mounting the door right or left. For a clean cosmetic appearance, each hinge includes two black rubber hole plugs to cover screws.

### Security Bracket (included with frame)

A security bracket, which mounts to the top of the bottom door, completes the dual door system. This bracket projects into the cabinet to within 1/4" of the mounting rails to secure the contents of the bottom section when the top door is open. The bracket will be factory installed when the frame system is ordered with the cabinet or may be field installed using two screws. This security bracket may also be field changed to the bottom of the top door or not used at all, if desired. Please note that since the bracket extends to within 1/4" of the mounting rails, equipment with protruding knobs may need to be repositioned to avoid the bracket.

### A & E Specifications

For separated and secured accessibility to rack-mounted equipment, each Lowell rack, cabinet, or sectional wall cabinet shall be equipped with a surface mounting dual front door system. The system shall include frame Model \_\_\_\_\_ (L46-77, L46-70, L46-61, L46-42, L46-36) plus top door Model \_\_\_\_\_ and bottom door Model \_\_\_\_\_. The surface mount 16-gauge steel frame shall extend 1" from the face of the cabinet and the surface mount doors shall extend 1" from the frame. Frame and doors shall attach without drilling to factory installed, threaded hinge inserts. Hinge inserts are located on the right and left to accommodate mounting on either side. Top and bottom doors shall be keyed different for security and shall be 16-gauge steel construction with an integral solid front, Plexiglas panel insert, or integral perforated front. Frame and doors shall be finished with Lowell's durable powder epoxy paint.

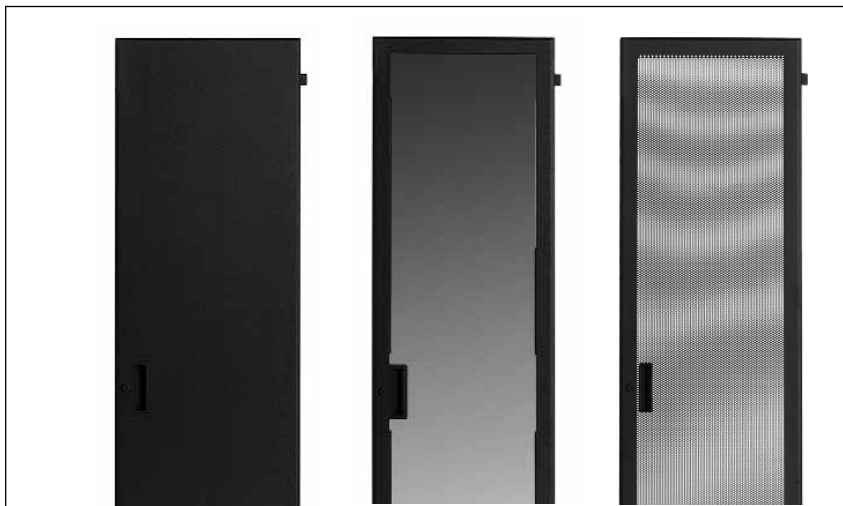

Order doors separately - styles may be mixed

Solid Door  
L2150 Series

Plexiglas Door  
L2150P Series

Perforated Door  
L2150PF Series