

CO2™

Coaxial-to-Optical and Optical-to-Coaxial Converter

Ver: CO2 052199

Introduction

Thank you for your purchase of the Midiman CO2 Coaxial/Optical Converter. CO2 is a compact but rugged S/PDIF tool that simultaneously converts S/PDIF signals from optical-to-coax, and coax-to-optical. CO2's innovative 2-in 2-out design allows it to operate as a full-duplex bidirectional converter, or as a half-duplex converter with "thru" port. This enables the CO2 to be used as a converter and a repeater.

Features

- Converts S/PDIF optical-to-coaxial and coaxial-to-optical, simultaneously.
- "Thru" ports may be used to extend the length of coaxial or optical runs.
- Three selectable modes of operation.
- Optical (Toslink) and RCA (coaxial) inputs and outputs.
- Power indicator LED.

Specifications

- Inputs: 1 Toslink optical and 1 RCA coaxial jack.
- Outputs: 1 Toslink optical and 1 RCA coaxial jack (transformer-isolated).
- Power supply: 9 Volts DC, center pin positive, 300 milliamps.
- Dimensions: 3.5" x 2.3" x 1.2".
- Approximate weight: 7 ounces.

Operation

Plug one end of the included power adapter into the CO2's power jack and the other end into a live wall socket or power strip. The power indicator LED on the side of the CO2 will light. Next, choose the CO2's mode of operation by setting the slide switch in the side of the CO2.

NOTE: The CO2's mode switch has been intentionally recessed in order to prevent accidental mode switching. Use a pen or similar object to set the switch position.

The CO2 has three different modes of operation:

- **OPTICAL --> COAX.** Data at the optical input is converted to coaxial output, and also copied "thru" to the optical output. See Figure 1 for an example. In this example, the CO2 is a converter and a repeater.
- **BI-DIRECTIONAL.** Data at the optical input is converted to coaxial output, and data at the coaxial input is converted to optical output. Both conversions occur simultaneously (also known as "full-duplex" operation). This is the most popular mode. See Figure 2 for an example. In this example, the CO2 is a bi-directional converter.

- **COAX --> OPTICAL.** Data at the coaxial input is converted to optical output, and also copied "thru" to the coaxial output. See Figure 3 for an example. In this example, the CO2 is a converter and a repeater.

After the switch has been set to the desired mode, connect the external S/PDIF devices.

NOTE: While it is usually desirable to set the CO2's mode switch before connecting external equipment, the switch setting may also be changed while external equipment is connected to the CO2. You might, however, hear small bursts of noise while switching - this is normal as it takes a small amount of time for external devices to "lock on" to the S/PDIF data stream after the switching takes place.

NOTE: For best results, when using the CO2 RCA jacks, use a good-quality S/PDIF cable. The cable should be coaxial with 75-ohm impedance. Vendors sell cables specifically for this use, but a good-quality video dubbing cable also has the proper characteristics.

If after reading this sheet you need additional tech support, or if you have comments or suggestions, we invite you to contact us directly by any one of the following methods:

MIDIMAN U.S.

45 East Saint Joseph Street
Arcadia, CA 91006-2861
U.S.A.

Sales Information: 626-445-2842
Sales Information (email): info@midiman.net
Tech Support: 626-445-8495
Tech Support (email): techsupt@midiman.net
Fax: 626-445-7564
Internet Home Page: http://www.midiman.net

MIDIMAN U.K.

Unit 22, Harrogate Business Park
Freemans Way

Harrogate
N Yorks
HG3 1DH
England
Sales Information: 01423 886692
Sales Information (email): midimanuk@compuserve.com
Technical Support: 01309 671301
Technical Support (email): richard@maudio.freereserve.co.uk
Fax: 01423 886693

MIDIMAN Deutschland (Germany)

Kuhallmand 34
D-74613 Ohringen Germany
Sales Information: 07941 98 7000
Sales Information (email): info@midiman.de
Technical Support: 07941 98 70030
Technical Support (email): support@midiman.de
Fax: 07941 98 70070
Internet Home Page: http://www.midiman.de



This product complies
with European CE
requirements.



Figure 1

Optical to Coaxial with Thru

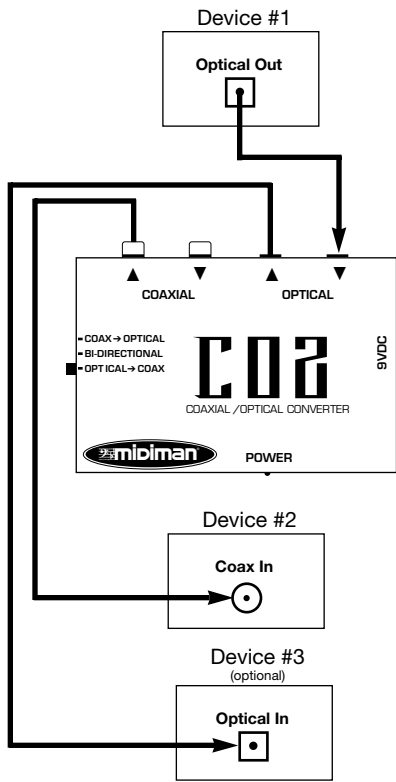

Figure 2

Optical to Coax, Coax to Optical or Both Simultaneously

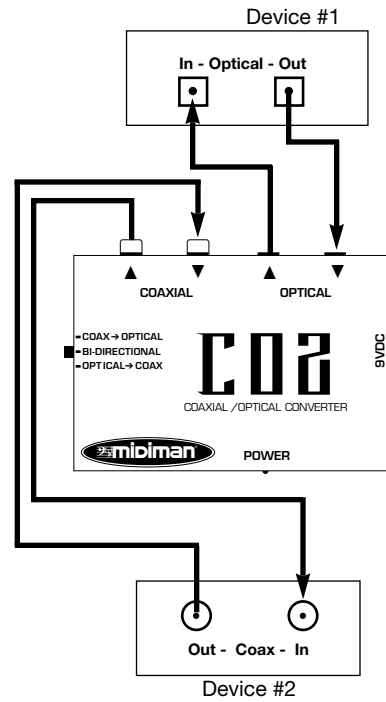

Figure 3

Coaxial to Optical with Thru

