



APPLICATION & ASSEMBLY INSTRUCTION

NAC3MX-W-TOP-L | powerCON® TRUE1 TOP

A. APPLICATION INSTRUCTION

APPLICATION:

- The powerCON TRUE1 system is certified as a connector with breaking capacity according IEC 60320, VDE 0625.
- It is intended for use as an appliance coupler and interconnection coupler.
- It serves to supply power to an appliance and from an appliance to other equipment.
- To be installed by qualified person only.

CONNECTOR ASSIGNMENT:

APPLIANCE INLET

NAC3MPX-TOP
NAC3MPX-WOT-TOP
Power IN ▶



NAC3FX-W-TOP-L

APPLIANCE OUTLET

NAC3FPX-TOP
NAC3FPX-WOT-TOP
NAC3FPX-ST-TOP
Power OUT ◀

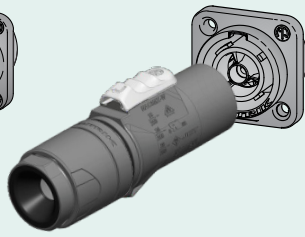

NAC3MX-W-TOP-L

APPLIANCE INLET / OUTLET ▶ Combination

NAC3PX-TOP
Power IN ▶

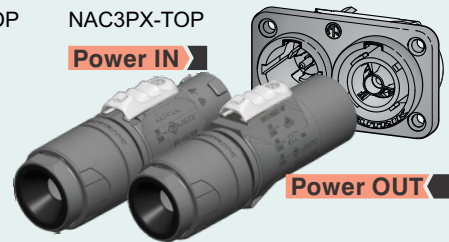

Power OUT ◀

NAC3MX-W-TOP-L

▶ powerCON TRUE1 TOP line is full backward compatible with the preceding powerCON TRUE1 products.

Approval based:

EUROPE
EN 60320-1



USA/CANADA

UL 60320-1
CAN/CSA-C22.2 No. 60320-1



Rating:

250 V ac / 16 A

250 V ac / 20 A

Wire size:

2.5 mm²

14 - 12 AWG

Compliance confirmed with:

H07RN-F

SOOW 12/3, SOOW 14/3

Cable O.D.:

10.0 - 16.0 mm (0.39 - 0.63")

10.0 - 16.0 mm (0.39 - 0.63")

B. ASSEMBLY INSTRUCTION

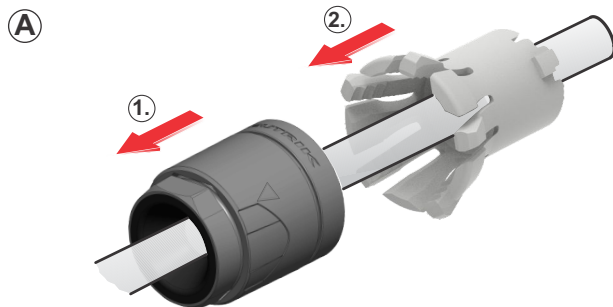

Place bushing (1) and chuck (2) over the cable.

Important: Chuck and Bushing cannot be placed over the cable after the assembly of the insert.

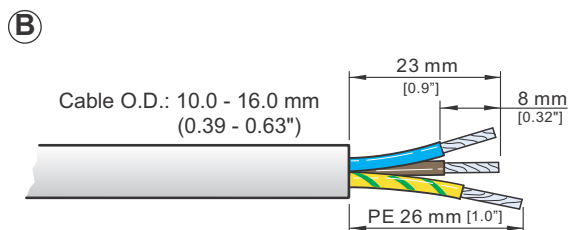

Prepare cable as shown.

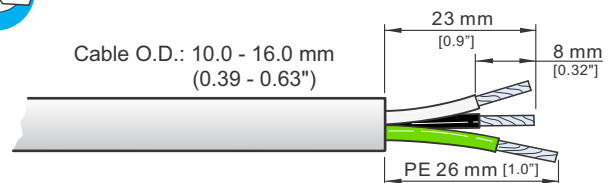

• **EUROPE**
(EN 60320-1)

• **USA/CANADA**
(UL60320-1 / CAN/CSA-C22.2 No. 60320-1)

C EUROPE

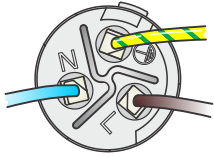

USA/CANADA

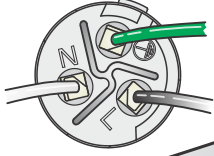

Torx size T8
Torque Value 0.7 Nm (6.2 inch pound)

Slide the cable into the contacts and clamp with the screw with Torx size T8.

Wiring	EUROPE	USA/CANADA
L ⇒	brown	black
N ⇒	blue	white
⏚ ⇒	green/yellow	green

D
Important:
Push and turn simultaneously.

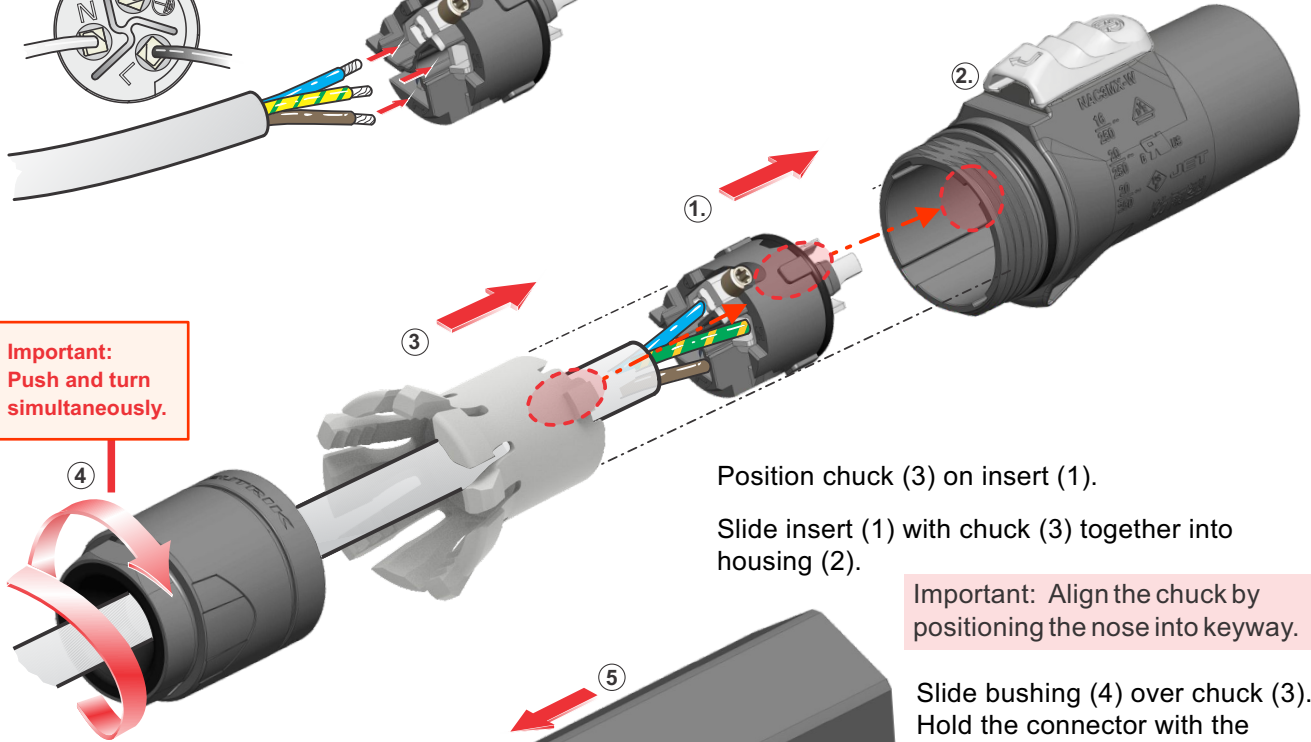

Position chuck (3) on insert (1).

Slide insert (1) with chuck (3) together into housing (2).

Important: Align the chuck by positioning the nose into keyway.

Slide bushing (4) over chuck (3). Hold the connector with the NEUTRIK tool (5) and tighten bushing with the NEUTRIK tool (6) as shown.

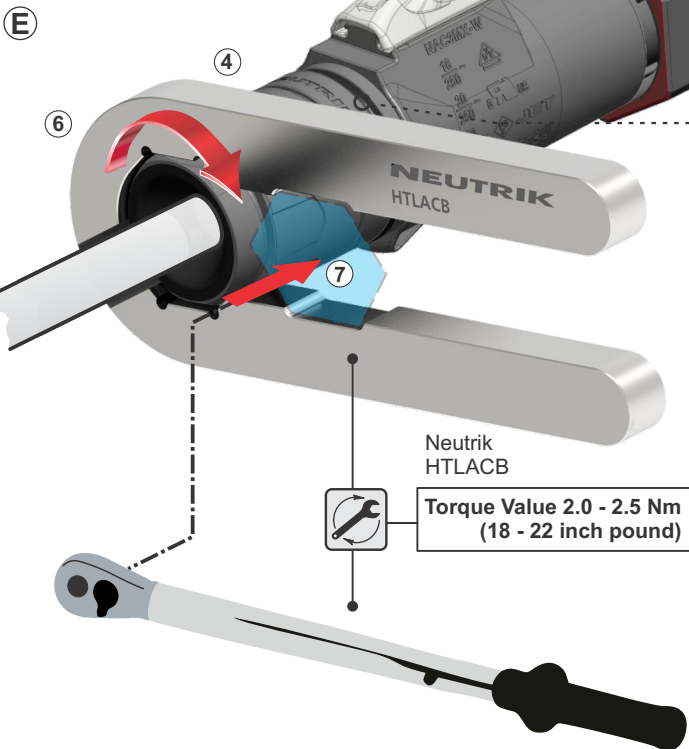

For an exact mounting position use a torque wrench with 19 mm (3/4 inch) hex bit (7) and tighten it with 2.0–2.5 Nm (18–22 inch pound).

Important: Black O-ring to be covered by the bushing to achieve IP protection (8).

NEUTRIK tool:	(5)	HTLACA
	(6)	HTLACB

FOR DISASSEMBLY!

1. Use the Neutrik tool HTLACB.
2. Position the tool on the surfaces and open the clamping sleeve.

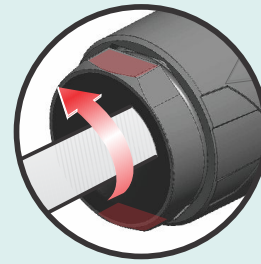

CAUTION

To ensure protection category, do not expose the connection to bending forces (e.g. do not attach loads to the cable, no free-dangling cable windings etc.).

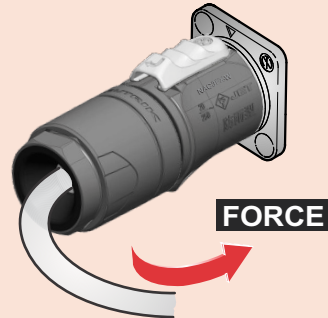

SAFETY WARNING

For safety and certification reasons the connector must be replaced in case of any broken parts or excessive wear and tear.

Find more details of powerCON TRUE1 TOP on www.neutrik.com.



Neutrik AG	LI	T: +423 / 237 24 24	F: +423/232 53 93	Neutrik France	FR	T: +33 1/4131 6750	F: +33 1/4131 0511
Neutrik USA Inc.	USA	T: +1 704 / 972 3050	F: +1 704/438 9202	Neutrik Tokyo Ltd.	JP	T: +81 3/3663 4733	F: +81 3/3663 4796
Neutrik (UK) Ltd.	UK	T: +44 1983 / 811 441	F: +44 1983/811 439	Neutrik Hong Kong Ltd.	HK	T: +852/2687 6055	F: +852/2687 6052
Neutrik Vertriebs GmbH	DE/NL/AT/DK	T: +49 8131 / 280 890	F: +49 8131/280 830				

Draft. Nr.: BDA 625 V1 | Update: 2021-11-18 | Data subject to change without prior notice. © 2021 NEUTRIK®, NEUTRIK® / powerCON® are registered trademark of Neutrik AG. ALL RIGHTS RESERVED.