

# ELP PAR

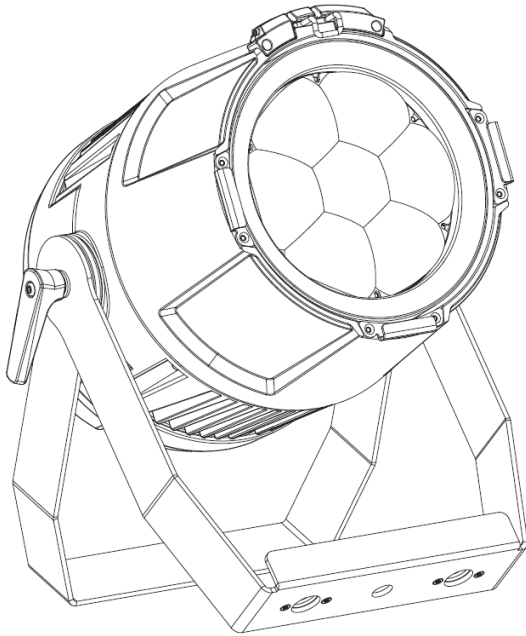

## User Guide

**Martin**<sup>®</sup>  
by HARMAN

©2021-2022 HARMAN PROFESSIONAL DENMARK ApS. All rights reserved. Features, specifications and appearance are subject to change without notice. HARMAN PROFESSIONAL DENMARK ApS and all affiliated companies disclaim liability for any injury, damage, direct or indirect loss, consequential or economic loss or any other loss occasioned by the use of, inability to use or reliance on the information contained in this document. Martin is a registered trademark of HARMAN PROFESSIONAL DENMARK ApS registered in the United States and/or other countries.

HARMAN PROFESSIONAL DENMARK ApS, Olof Palmes Allé 44, 8200 Aarhus N,  
Denmark  
HARMAN PROFESSIONAL SOLUTIONS U.S., 8500 Balboa Blvd., Northridge CA 91329,  
USA

**[www.martin.com](http://www.martin.com)**

ELP PAR User Guide Revision A

# Table of contents

Safety information.....	4
Introduction.....	9
Before using the product for the first time .....	9
Fixture overview .....	10
Physical installation .....	11
Standing the fixture on a flat, horizontal surface .....	12
Fastening the fixture to a flat surface .....	13
Mounting the fixture on a truss.....	13
Securing with a safety cable .....	14
Connecting to AC power.....	15
Linking fixtures to power in a chain .....	16
Connecting to data .....	17
Tips for reliable data transmission .....	17
Connecting the DMX data link.....	17
Fixture setup.....	18
DMX address setting.....	19
Raw, extended and calibrated modes.....	19
Tungsten emulation mode .....	20
Dimming curves .....	20
Dimming speed and smoothness.....	20
Blackout or Hold if DMX signal stops.....	21
Cooling mode.....	21
Display rotation .....	22
Display intensity.....	22
Temperature units.....	22
Resetting to factory defaults .....	22
Fixture test .....	23
Fixture information .....	23
DMX Live .....	25
Resetting the fixture .....	25
Manual control .....	25
Focus shortcut .....	26
Control / Settings DMX channel.....	26
Effects .....	28
RDM .....	29
Maintenance .....	31
Cleaning.....	31
Uploading new firmware .....	32
Service and repairs .....	33
DMX protocol.....	34
Control menus .....	38
Troubleshooting.....	42
Dimensions.....	43
Specifications .....	44

# Safety information



## WARNING!

**Read the safety precautions in this manual before installing, operating or servicing this product.**

The following symbols are used to identify important safety information on the product and in this manual:



**Warning!**

***Safety hazard.  
Risk of severe  
injury or death.***



**Warning!**

***Powerful light  
emission. Risk  
of eye injury.***



**Warning!**

***See user  
manual for  
important  
safety  
information.***



**Warning!**

***Hazardous  
voltage. Risk  
of lethal or  
severe electric  
shock.***



**Warning!**

***Hot surfaces  
and fire  
hazard.***



**Warning!** Risk Group 2 product according to EN 62471 and IEC/TR 62778. Possibly hazardous radiation emitted from this product. May be harmful to the eyes. Do not stare at operating lamp and do not view the light output with optical instruments or any device that may concentrate the beam.

This lighting fixture is for professional use only and must be installed by a qualified technician. It is not for household use. It presents risks of severe injury or death due to fire hazards, electric shock and falls. It produces a powerful, concentrated beam of light that can create a fire hazard or a risk of eye injury if the safety precautions below are not followed. Respect all locally applicable laws, codes and regulations when installing, operating or servicing the fixture.

The light source contained in this fixture must be replaced by Martin Service or an authorized Martin Service partner only.



Install, operate and service Martin products only as directed in their user manuals, or you may create a safety hazard or cause damage that is not covered by product warranties.

Follow the safety precautions listed below and observe all warnings in this manual and printed on the product. Before you install, operate or service the fixture, check the Martin website at [www.martin.com](http://www.martin.com) and make sure that you have the latest user documentation for the fixture. Document revisions are indicated at the bottom of page 2.

### **Technical Support**

If you have questions about how to install or operate the fixture safely, please contact Harman Professional Technical support:

- For technical support in North America, please contact:  
HProTechSupportUSA@harman.com  
Phone: (844) 776-4899
- For technical support outside North America, please contact your national distributor.



### **Protection from electric shock**

Do not expose the fixture to rain or moisture.

Disconnect the fixture from AC power before carrying out any installation or maintenance work and when the fixture is not in use.

Ensure that the fixture is electrically connected to ground (earth).

Use only a source of AC power that complies with local building and electrical codes and has both overload and ground-fault (earth-fault) protection.

Socket outlets or external power switches used to supply the fixture with power must be located near the fixture and easily accessible so that the fixture can easily be disconnected from power.

Isolate the fixture from power immediately if the power plug or any seal, cover, cable, or other component is damaged, defective, deformed, wet or showing signs of overheating. Do not reapply power until repairs have been completed.

Before using the fixture, check that all power distribution equipment and cables are in perfect condition and rated for the current requirements of all connected devices.

Use only Neutrik PowerCON TRUE1 TOP cable connectors to connect to the fixture's power sockets.

Do not connect devices to power in a chain that will exceed the electrical ratings of any cable or connector used in the chain.

To connect fixtures to mains power in a chain, you must first obtain 12 AWG or 2.5 mm<sup>2</sup> power input and throughput cables that are 16 A rated and temperature-rated to suit the application. In the USA and Canada the cables must be UL-listed, type SJT or equivalent. In the EU the cables must be type H05VV-F or equivalent. Suitable cables with Neutrik PowerCON TRUE1 TOP connectors are available from Martin (see 'Accessories' on page 46). If you use these cables, you can connect fixtures to power in a linked chain, POWER OUT throughput socket to POWER IN input socket, but do not link more than:

- four (4) ELP PAR fixtures in total at 100-120 V, or
- seven (7) ELP PAR fixtures in total at 200-240 V.

If you intend to connect other devices to the POWER OUT socket in a daisy chain, add together the maximum current draw of all the devices in the chain. Do not create a chain of devices whose total maximum current draw will exceed the maximum current rating of any connector in the chain. The maximum permitted current at the POWER IN connector is 16 A. The maximum permitted current at the POWER OUT connector is 12 A.

The voltage and frequency at the POWER OUT socket are the same as the voltage and frequency applied to the POWER IN socket. Only connect devices to the POWER OUT socket that accept this voltage and frequency.

### **Protection from burns and fire**

Do not operate the fixture if the ambient temperature ( $T_a$ ) exceeds 40° C (104° F).

The surface of the product casing can reach up to 65° C (149° F) – TBC during operation. Avoid contact by persons



and materials. Allow the fixture to cool for at least 15 minutes before handling.

Keep flammable materials well away from the fixture. Keep all combustible materials (e.g. fabric, wood, paper) at least 0.5 m (1.7 ft.) away from the fixture housing.

Ensure that there is free and unobstructed airflow around the fixture. Provide a minimum clearance of 0.5 m (1.7 ft.) around fans and air vents.

Do not use the fixture to illuminate surfaces within 1 m (3.3 ft.) of the fixture.

Do not stick filters, masks or other materials onto any optical component.

The fixture's lenses can focus the sun's rays, creating a risk of fire and damage. Do not expose the front of the fixture to sunlight or any other bright light source.



### Protection from eye injury

Warning! Risk Group 2 product according to EN 62471 and IEC/TR 62778.

The ELP PAR fixture falls into the following risk groups according to EN 62471 and IEC/TR 62778 at the distances indicated below.

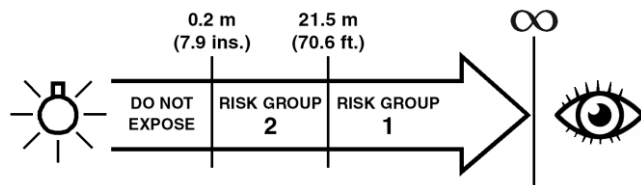

The luminaire should be positioned so that prolonged staring into the luminaire at a distance closer than 21.5 m is not expected.

Do not look directly into the product's light output.

Do not look at operating lamp. Eye injury may result.

Do not look at the light output with magnifiers, telescopes, binoculars or similar optical instruments that may concentrate the light output.

Ensure that persons are not looking directly into the front of

the fixture when the product lights up suddenly. This can happen when power is applied, when the product receives a DMX signal, or when certain control menu items are selected.

To minimize the risk of eye irritation or injury, disconnect the fixture from power at all times when the fixture is not in use and provide well-lit conditions to reduce the pupil diameter of anyone working on or near the fixture.



### **Protection from injury**

The fixture is not portable when installed.

Ensure that any supporting structure and/or hardware used can hold at least 10 times the weight of all the devices they support.

If suspending from a rigging structure, fasten the fixture to a rigging clamp. Do not use safety cables as the primary means of support.

If the fixture is installed in a location where it may cause injury or damage if it falls, install as directed in this manual a secondary attachment such as a safety cable that will hold the fixture if a primary attachment fails. The secondary attachment must be approved by an official body such as TÜV as a safety attachment for the weight that it secures, must comply with EN 60598-2-17 Section 17.6.6 and must be capable of bearing a static suspended load that is ten times the weight of the fixture and all installed accessories.

Check that all external covers and rigging hardware are securely fastened.

Block access below the work area and work from a stable platform whenever installing, servicing or moving the fixture.

Do not operate the fixture with missing or damaged covers, shields or any optical component.

In the event of an operating problem, stop using the fixture immediately and disconnect it from power. Do not attempt to use a fixture that is obviously damaged.

Do not modify the fixture in any way not described in this manual or install other than genuine Martin parts.

Refer any service operation not described in this manual to a qualified technician.



# Introduction

The ELP PAR is a bright single-lens LED PAR Can with calibrated color output from seven RGBW LEDs and a motorized zoom with an angle that varies from 5.6° to 57.6° (field angle, one-tenth peak) or 4.2° to 35.4° (beam angle, half-peak). It offers electronic dimming and strobe and features a bracket for floor or truss mounting.

The ELP PAR can be controlled using any DMX-compliant controller.

The fixture is supplied with a folding mounting bracket.

## Before using the product for the first time

1. Read 'Safety information' on page 4 before installing, operating or servicing the fixture.
2. Unpack and ensure that there is no transportation damage before using the fixture. Never attempt to operate a damaged fixture.
3. Check that the voltage and frequency of the local power source match the mains power requirements of the fixture.
4. Either hard-wire the fixture to an AC mains power source or provide a power input cable and local power plug as described in this manual and connect to an AC mains power outlet.
5. Check the support pages on the Martin Professional website at [www.martin.com](http://www.martin.com) for the most recent user documentation and technical information about the fixture. Martin user manual revisions are identified by the revision letter at the bottom of the inside cover.

When the fixture is powered on for the first time, it may smoke slightly as it warms up, but this will only last a few minutes and is no cause for concern. Be prepared for the fixture to suddenly emit bright light when power is applied.

## Fixture overview

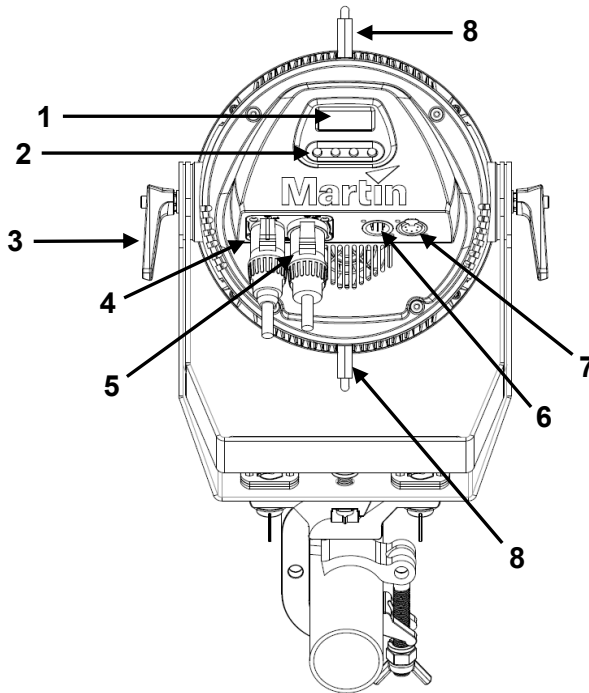

- 1 - Display
- 2 – Control buttons
- 3 – Tilt adjustment handle
- 4 – Mains power IN (Neutrik PowerCON TRUE1 TOP)
- 5 – Mains power OUT / THRU (Neutrik PowerCON TRUE1 TOP)
- 6 – DMX IN (Neutrik 5-pin XLR)
- 7 – DMX OUT / THRU (Neutrik 5-pin XLR)
- 8 – Carabiner clips (not supplied) for safety cable

## Physical installation



Read 'Safety information' on page 4 before installing the fixture.

**Warning!** See illustration below. Position or shade the head so that the front of the head will not be exposed to sunlight or any other strong light source from any angle – even for a few seconds. The fixture can focus the sun's rays internally, creating a risk of fire and damage.



The fixture is designed for indoor use only and must be used in a dry location with adequate ventilation. Ensure that none of the fixture's ventilation slots are blocked.

You can either fasten the fixture to a secure structure (such as a rigging truss) or surface. You can also stand it on a secure surface. Do not place the fixture in a location where it can be moved, fall over, or present a danger of tripping or injury.

If you install the fixture in a location where it may cause injury or damage if it falls, secure it as directed in this user manual using a securely anchored safety cable that will hold the fixture if the primary fastening method fails.

Martin can supply safety cables and rigging clamps that are suitable for use with the fixture (see 'Accessories' on page 46).

### **Avoiding damage from other light sources**

**Important!** Do not point the light output from other lighting fixtures at the ELP PAR, as powerful light can damage the display.

## Mounting bracket angle scales

See illustration on right. The fixture's mounting bracket has angle scales printed on both sides next to the adjustment handles. The scales show the precise angle at which the head is tilted. There are two scales. The inner scale is for use when standing the fixture on the floor. The outer scale is for use when flying the fixture overhead.

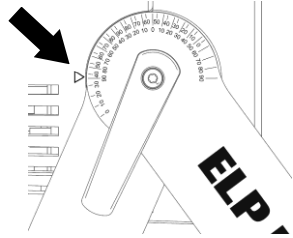

## Standing the fixture on a flat, horizontal surface

Use a stable horizontal surface that can support at least 10 times the weight of all the fixtures and equipment that it will support.

See illustration on right. The fixture can be placed on the surface by releasing the adjustment handles (arrowed) on both sides of the fixture, fully opening the legs of the mounting bracket, and then re-tightening the adjustment handles.

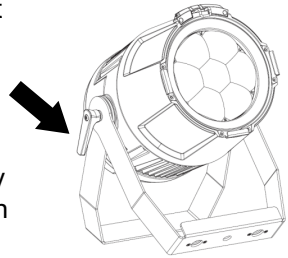

## Fastening the fixture to a flat surface

Use a stable horizontal surface that can support at least 10 times the weight of all the fixtures and equipment that it will support. Ensure that all fasteners used can support at least ten times the weight of all the fixtures and equipment that they will support.

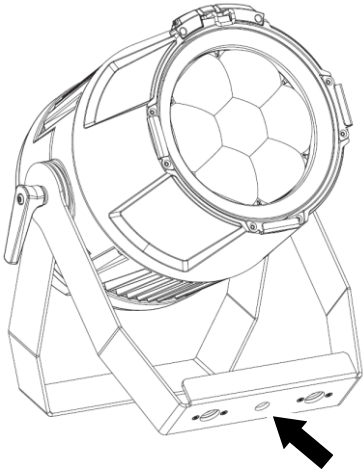

To fasten the fixture to a surface:

1. See illustration on left. Pass an M12, grade 8.8 steel minimum, bolt or screwbolt through the hole (arrowed) in the center of the main mounting bracket leg and into the surface.
2. If using a bolt, secure with a washer and self-locking nut.
3. Check that the fixture is held securely.
4. If you install the fixture in a location where it may cause injury or damage if it falls, secure it as directed below with a securely anchored safety cable that will hold the fixture if the primary fastening method fails.

## Mounting the fixture on a truss

The fixture can be clamped to a truss or similar rigging structure in any orientation. When installing the fixture hanging vertically down, you can use an open-type clamp such as a G-clamp. When installing in any other orientation, you must use a half-coupler clamp (see illustration on right) that completely encircles the truss chord.



To clamp the fixture to a truss:

1. Check that the rigging structure can support at least ten times the weight of all fixtures and equipment to be installed on it.
2. Block access under the work area.
3. Either:
  - Bolt a rigging clamp directly to the fixture's mounting bracket using an M12 grade 8.8 steel bolt and self-locking washer, or

- Bolt a rigging clamp to a Martin omega bracket (available as an accessory by ordering P/N 91602001 from your Martin supplier) using a grade 8.8 steel bolt. See illustration on right. Fold the legs of the fixture's mounting bracket together and fasten the omega bracket securely to the mounting bracket. Turn the quarter-turn fasteners on the omega bracket a full 90° to lock.

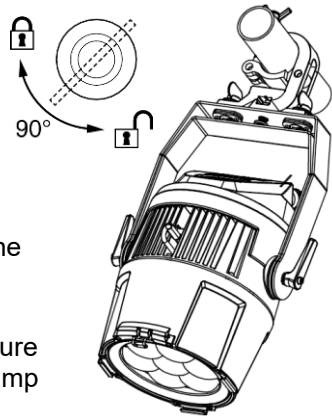

4. Working from a stable platform, hang the fixture with its clamp on the truss and fasten the clamp securely.
5. Loosen the adjustment handles on both sides of the fixture, adjust the fixture's tilt angle, and re-tighten the handles.
6. Secure the fixture with a safety cable as directed below.

### Securing with a safety cable

1. Obtain a safety cable (or other secondary attachment) that is approved for the weight of the fixture.
2. See illustration on right. There is one attachment point (arrowed) in the cooling vent on the top of the fixture and a second, identical attachment point on the bottom of the fixture. Fasten the cable to one of the safety cable attachment points (arrowed) on the fixture by either looping it around the attachment point or using a carabiner clip.

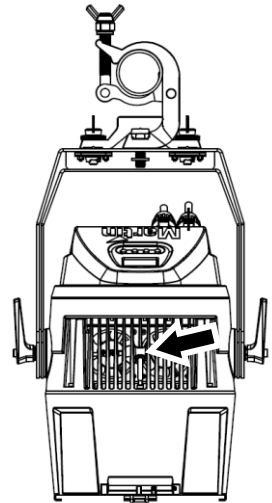

Do not simply loop the safety cable around the legs of the mounting bracket, as this will leave the fixture unsecured if the fixture separates from the mounting bracket.

3. Remove as much slack as possible from the safety cable and fasten it to a secure anchoring point.
4. Make sure that the safety cable will hold the fixture if a primary attachment fails.

Your Martin dealer can supply suitable safety cables and rigging clamps (see 'Accessories' on page 46).

## Connecting to AC power



Read ‘Safety information’ on page 4 before connecting the fixture to AC mains power.



Before you connect other fixtures to the POWER OUT socket, see ‘Linking fixtures to power in a chain’ on page 16.

For protection from electric shock, the fixture must be grounded (earthed). The power distribution circuit must be equipped with a fuse or circuit breaker and ground-fault (earth-fault) protection.

Socket outlets or external power switches used to supply the fixture with power must be located near the fixture and easily accessible so that the fixture can easily be disconnected from power.

Do not use an external dimming system to supply power to the fixture, as this may cause damage to the fixture that is not covered by the product warranty.

The fixture requires a power input cable with a Neutrik powerCON TRUE1 NAC3FX-W (TOP) female cable connector for AC mains power input. The cable must meet the requirements listed under “**Protection from electric shock**” on page 5. Martin can supply suitable cables with female TRUE1 TOP input connectors 1.5 m (4.9 ft.) or 5 m (16.4 ft.) long, as well as loose female TRUE1 TOP input connectors (see “Accessories” on page 46).

The fixture can be hard-wired to a building electrical installation if you want to install it permanently, or a power plug that is suitable for the local power outlets can be installed on the power cable. If you install a power plug on the power cable, follow the plug manufacturer’s instructions and connect the wires in the power cable as shown in this table:

	Earth, Ground or 	Neutral or N	Live or L
<b>US system</b>	Green	White	Black
<b>EU system</b>	Yellow/green	Blue	Brown

The fixture has an auto-ranging power supply that accepts AC mains power at 100-120/200-240 V at 50/60 Hz. Do not apply AC mains power at any other voltage or frequency to the fixture.

## Linking fixtures to power in a chain

If you obtain a 12 AWG / 2.5 mm<sup>2</sup> power input cable and 12 AWG / 2.5 mm<sup>2</sup> throughput cables from Martin (see “Accessories” on page 46), you can relay mains power from one fixture to another by connecting fixtures to power in a linked daisy-chain, POWER OUT throughput socket to POWER IN input socket.

Using 12 AWG / 2.5 mm<sup>2</sup> cables from Martin, you can create a daisy chain of linked fixtures that contains:

- maximum four (4) ELP PAR fixtures in total at 100-120 V, or
- maximum seven (7) ELP PAR fixtures in total at 200-240 V.



## Connecting to data

A DMX 512 data link is required in order to control the fixture via DMX. The fixture has 5-pin XLR connectors for DMX data input and output.

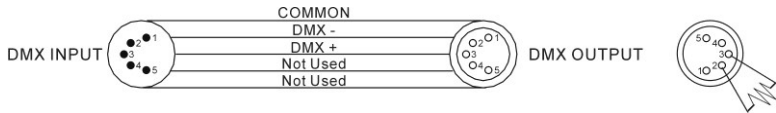

The number of daisy-chained fixtures is limited by the number of DMX channels required by the fixtures in relation to the maximum 512 channels available in one DMX universe. Note that if independent control of a fixture is required, it must have its own DMX channels. Fixtures that are required to behave identically can share the same DMX address and channels. To add more fixtures or groups of fixtures when the above limit is reached, add a DMX universe and another daisy-chained link.

### Tips for reliable data transmission

Use shielded twisted-pair cable designed for RS-485 devices: standard microphone cable cannot transmit control data reliably over long runs. 24 AWG cable is suitable for runs up to 300 meters (1000 ft.). Heavier gauge cable and/or an amplifier is recommended for longer runs. The pinout on all connectors is pin 1 = shield, pin 2 = cold (-), and pin 3 = hot (+). Pins 4 and 5 in the 5-pin XLR connectors are not used in the fixture but are available for possible additional data signals as required by the DMX512-A standard. Standard pinout is pin 4 = data 2 cold (-) and pin 5 = data 2 hot (+).

If you need to split the link into branches, use a splitter such as the Martin RDM 5.5 Splitter.

Terminate the link by installing a DMX termination plug in the output socket of the last fixture. The termination plug, which is a male XLR plug with a 120 Ohm, 0.25 W resistor soldered between pins 2 and 3, “soaks up” the control signal so it does not reflect and cause interference. If a splitter is used, terminate each branch of the link.

### Connecting the DMX data link

To connect the fixture to data:

1. Connect the DMX data output from the controller to the first fixture’s male XLR DMX input connector.
2. Connect the first fixture’s DMX output to the DMX input of the next fixture and continue connecting fixtures output to input. Terminate the last fixture on the link with a DMX termination plug.

# Fixture setup

This section explains the fixture characteristics that can be set to determine how it can be controlled and will behave. These settings are made using the menus available in the control panel. Settings are retained in memory when the fixture is powered off.



You can find a complete map of the control menu structure in 'Control menus' on page 38.

## **Using the control menus**

- To access the control menu or to return to the next highest level in the menu structure, press the MENU button.
- Navigate the menu structure using the DOWN, UP and ENTER buttons.
- If you have selected a menu option, confirm your selection and set that option using the ENTER button, or if you want to return to the next highest level in the menu structure without making a change, press the MENU button.
- To exit the menus, press the MENU button.

## **Special keypress functions**

- Holding the UP button and pressing the DOWN button rotates the control panel display through 180°.
- Holding the MENU button and pressing the UP button resets the entire fixture.
- Holding the ENTER button pressed for 5 seconds puts the fixture into Focus shortcut mode for one minute (see 'Focus shortcut' on page 26).

MENU	<ul style="list-style-type: none"><li>• Activate the control menus, or</li><li>• Open the Shortcuts menu by holding for 2 seconds, or</li><li>• Return to the previous level of the menu structure, or</li><li>• Press to exit the menus</li></ul>
 DOWN	Go down a menu level
 UP	Go up a menu level
ENTER	Confirm the selected function

## **Menu shortcuts**

Pressing and holding the MENU button for two seconds opens a small Shortcuts menu with two items:

- RESET ALL carries out a complete reset of the fixture with all its effects.
- ROTATE DISPLAY rotates the control panel display through 180°. This function makes it easier to read the control panel menus when changing from standing to hanging installation.

## **DMX address setting**

The DMX address, also known as the start channel, is the first channel used to receive instructions from a DMX controller. The fixture uses 14 DMX channels. This means that if you have a group of fixtures and you set the first fixture's DMX address to 1, then DMX address 15 is available for the next fixture, DMX address 29 for the fixture after that, and so on.

For independent control, each fixture must be assigned its own control channels. You can give the same DMX address to two fixtures of the same type if you want them to behave identically. Giving the same DMX address to multiple fixtures can be useful for grouped control and troubleshooting.

To set the fixture's DMX address:

1. In the fixture's control panel, use the UP and DOWN buttons to select DMX ADDRESS and press ENTER. The fixture's currently set DMX address will blink in the display.
2. Use the UP and DOWN buttons to select a new address.
3. Once the new address has been selected, press ENTER to confirm it (or press MENU to exit without making a change).

## **Raw, extended and calibrated modes**

In **raw** mode, all LEDs operate at full intensity and CTC (color temperature correction) functionality is disabled. The color output of one fixture may or may not closely match that of other fixtures, depending on LED binning.

In **extended** mode, mixed white is calibrated, giving perfect white matching across multiple fixtures, but primary and secondary colors are not calibrated, which allows maximum color saturation. The closer you move towards white, the more closely multiple fixtures will match each other's output. The further you move away from white and the closer you move towards saturated color, the less closely multiple fixtures will match each other's output.

In **calibrated** mode, white and color are fully calibrated. This means that the output of multiple fixtures will match with no visible differences. On the other hand, color saturation will be slightly less heavy.

## Tungsten emulation mode

In tungsten emulation mode, the fixture's white light output is made warmer, the warm shift is increased at lower dimming levels, and an 'afterglow' effect is added after dimming. This mode gives the 'look and feel' of a fixture that uses a 2800 K incandescent light bulb as its source.

## Dimming curves

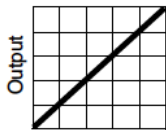

Optically linear

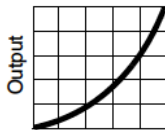

Square law

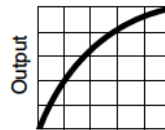

Inverse square law

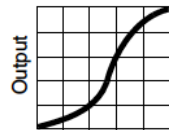

S-curve

Four dimming curves are available:

**LINEAR** – The increase in light intensity appears to be linear as DMX value is increased.

**SQUARE LAW** – light intensity control is finer at low levels and coarser at high levels.

**INVERSE SQUARE LAW** – light intensity control is coarser at low levels and finer at high levels.

**S-CURVE** – light intensity control is finer at low levels and high levels and coarser at medium levels.

To set the fixture's dimming curve:

1. Select DIMMER CURVE and press ENTER. The currently set dimming curve mode will blink in the display.
2. Use the DOWN and UP buttons to select LINEAR, SQUARE LAW, INV SQ LAW, or S-CURVE.
3. Press ENTER to confirm your choice (or press MENU to exit without making a change).

## Dimming speed and smoothness

You can optimize dimming to give either the fastest or the smoothest changes in dimming levels. To optimize dimming:

1. Select DIMMING SPEED and press ENTER.
2. Use the DOWN and UP buttons to select FAST (dimmer optimized for speed) or SMOOTH (dimmer optimized for smoothness).
3. Press ENTER to confirm your choice (or press MENU to exit without making a change).

## Blackout or Hold if DMX signal stops

You can decide how the fixture should behave if you are controlling the fixture via DMX and then you stop sending the DMX data signal:

1. Select NO DATA MODE and press ENTER. The currently set mode will blink in the display.
2. Using the DOWN and UP buttons, select BLACKOUT or HOLD to decide how the fixture should respond if it stops receiving a DMX signal:
  - If you select BLACKOUT, the fixture will black out
  - If you select HOLD, the fixture will continue to show the effect that it is displaying at the time.
3. Press ENTER to confirm your choice (or press MENU to exit without making a change).

## Cooling mode

The cooling mode setting lets you decide whether to give priority to lowest noise level or maximum light output:

1. Select COOLING MODE and press ENTER. The currently set mode will blink in the display.
2. Using the DOWN and UP buttons, select one of the three cooling options:
  - If you select REGULATED FANS, the fans operate at normal speed. Temperature regulation increases fan speed if the fixture approaches its maximum operating temperature. This setting provides a good compromise between low fan noise and powerful light output.
  - If you select THEATER MODE, the fans operate at lower speed. Temperature regulation reduces maximum light output if the fixture approaches its maximum operating temperature. This setting gives priority to the lowest possible noise.  
The THEATER MODE setting also increases the LED PWM frequency to 19 200Hz to ensure flicker-free high speed video recording.
  - If you select FULL, the fans operate at full speed without temperature regulation. This setting maximizes cooling and gives priority to the highest possible light output intensity.
3. Press ENTER to confirm your choice (or press MENU to exit without making a change).

## Display rotation

The fastest way to rotate the control panel display through 180° to match the fixture's orientation is to press and hold the UP button and then press the DOWN button.

You can also rotate the display using the DISPLAY control menu:

1. Select DISPLAY → DISPLAY ROTATION and press ENTER.
2. Use the DOWN and UP buttons to select NORMAL (display in normal orientation) or ROTATE 180° (display inverted to make it easier to read if you install the fixture hanging vertically from its mounting bracket).
3. Press ENTER to confirm your choice (or press MENU to exit without making a change).

## Display intensity

To set the brightness of the control panel display:

1. Select DISPLAY → DISPLAY INTENSITY and press ENTER.
2. Use the DOWN and UP buttons to adjust the brightness of the display from 10% to 100%.
3. Press ENTER to confirm your choice (or press MENU to exit without making a change).

## Temperature units

To set the fixture to display temperatures in degrees Celsius or Fahrenheit:

1. Select DISPLAY → TEMPERATURE UNIT and press ENTER.
2. Use the DOWN and UP buttons to select °C or °F.
3. Press ENTER to confirm your choice (or press MENU to exit without making a change).

## Resetting to factory defaults

To reset the fixture to its factory default settings:

1. Select FACTORY DEFAULT and press ENTER to confirm.
2. Use the DOWN and UP buttons to select YES to erase any custom settings that you have configured and reset the fixture to its factory default settings, or select NO.
3. Press ENTER to confirm your choice (or press MENU to exit without making a change).

## **Fixture test**

You can run an automatic sequence to test all the fixture's effects or manually test individual effects using the control menus.

### ***Automatic effects test***

To perform a complete test of all of the fixture's effects:

1. Select **FIXTURE TEST** → **TEST ALL** and press **ENTER** to confirm. The automatic test will run.
2. To stop the test and return to the previous level of the menu structure, press **MENU**.

### ***Manual effects tests***

You can also manually test individual effects.

To test LED dimming:

1. Select **FIXTURE TEST** → **TEST DIMMER** and press **ENTER**.
2. To stop the test and return to the previous level of the menu structure, press **MENU**.

To test an individual effect:

1. Select **FIXTURE TEST** → **TEST EFFECTS** and press **ENTER**.
2. Use the **DOWN** and **UP** buttons to select **RED**, **GREEN**, **BLUE**, **CTC**, **COLOR** (this tests the virtual color wheel effect), or **ZOOM**. Press **ENTER** to confirm your selection. The fixture will now run an automatic test of the selected effect.
3. Press **MENU** to exit the test and return to the list of effects.

## **Fixture information**

### ***Power on time***

1. Select **INFORMATION** → **POWER ON TIME** and press **ENTER** to display the total number of hours the fixture has been powered on since it left the factory.
2. To return to the previous level of the menu structure, press **MENU**.

### ***LED operating time***

1. Select **INFORMATION** → **LED HOURS** and press **ENTER** to display the total number of hours the LEDs have been activated since the fixture left the factory.
2. To return to the previous level of the menu structure, press **MENU**.

## ***Firmware version***

To see which software version is installed in the fixture:

1. Select INFORMATION → SW VERSION and press ENTER. The display will indicate the currently installed firmware version.
2. Use the UP and DOWN buttons to scroll through firmware revisions.
3. To return to the previous level of the menu structure, press MENU.

## ***Fixture ID number***

You can set a custom 4-digit ID number for the fixture to help you identify it.

To manage the ID number:

1. Select INFORMATION → FIXTURE ID and press ENTER. The display will indicate the current fixture ID number.
2. Use the DOWN and UP buttons to increase or decrease the current fixture ID number until you reach the ID number that you want to allocate to the fixture.
3. Press ENTER to confirm the new ID number (or press MENU to exit without making a change).

## ***RDM unique ID number***

You can view the fixture's unique non-resettable 12-digit RDM ID number.

To view the RDM UID number:

1. Select INFORMATION → RDM UID and press ENTER. The display will indicate the fixture's unique RDM ID number.
2. Press MENU to exit.

## ***Fixture temperature readouts***

To check the onboard temperature of the fixture:

1. Select INFORMATION → TEMPERATURES and press ENTER. The fixture will display on two lines the current temperatures of the LED PCB and of the PSU PCB.
2. To return to the previous level of the menu structure, press MENU.

## ***Fan speed readouts***

To view the current speed of each of the fixture's cooling fans in RPM:

1. Select INFORMATION → FAN SPEED and press ENTER. The fixture will display on two lines the current speeds in RPM of the LED PCB cooling fan and of the PSU PCB cooling fan.
2. To return to the previous level of the menu structure, press MENU.



## DMX Live

You can view the DMX values currently being received on each of the fixture's DMX channels. This can be useful for troubleshooting purposes.

To view the DMX values being received:

1. Select DMX LIVE and use the UP and DOWN buttons to scroll through the value being received on each channel.
2. To return to the previous level of the menu structure, press MENU.

## Resetting the fixture

You can reset the entire fixture to return it to its state when you powered it on, or you can reset its effects only.

- To carry out a full reset, select MANUAL CONTROL → RESET → ALL, select YES or NO and press ENTER. The entire fixture will reset as if you had cycled power. The reset process will take several seconds.
- To reset only the fixture's effects, select MANUAL CONTROL → RESET → EFFECTS and press ENTER. The fixture's effects will reset. The effects reset process will take several seconds.

## Manual control

You can control the fixture's effects manually without needing a DMX signal. This lets you set up a stand-alone scene.

To manually control the fixture:

1. Select MANUAL CONTROL and then use the UP and DOWN buttons to scroll to the effect that you want to control. Press ENTER.
2. Use the UP and DOWN buttons to scroll to the DMX value from 000 to 255 that you want to send to that effect. Press ENTER to confirm and send that value.
3. To return to the list of effects, press MENU.
4. If you want to manually control other effects together with the first effect, repeat steps 1. and 2. and 3. above for the other effects. When you have finished setting effects, return to the previous level of the menu structure, by pressing MENU.

The fixture will continue to show the effects that you have set manually until you set new manual control values for the effects. The effects are unaffected by a power OFF/ON cycle: if you power the fixture off and on again, it will resume showing the effects.

To stop the effects, open the DMX SETUP menu. This will immediately stop all manually controlled effects.

When in manual control mode, pressing any button on the control panel lights up the control panel display and shows the message MANUAL CONTROL MODE.

## **Focus shortcut**

The fixture features a 'focus shortcut' mode that lets you adjust the zoom effect. This can be useful if you are setting up multiple fixtures in the rig and want to match the appearance of their projected beams.

To adjust the zoom effect:

1. Hold ENTER for 5 seconds. Focus shortcut mode is now enabled for one minute. Light output switches to full white and zoom moves to narrow
2. Use the UP and DOWN buttons to adjust the zoom effect for optimum angle and position.
3. To return to the previous level of the menu structure, press MENU.

DMX control is disabled while the fixture is in 'focus shortcut' mode.

## **Control / Settings DMX channel**

The Control / Settings DMX channel lets you configure certain fixture settings remotely via DMX. The control / settings functions require you to hold the required DMX value for a certain number of seconds to implement them (see DMX protocol section on page 34).

The following options are available on the Control / Settings DMX channel:

### ***Hibernation mode***

Hibernation mode sets light output intensity to zero and disables effect deployment.

The main purpose of this mode is to protect the fixture from the intake of airborne material such as dust and confetti and to provide an option for situations where noise is critical. The small reduction in power consumption obtained in hibernation mode is not the mode's main purpose.

When you bring the fixture out of hibernation mode, it performs a full reset.

### ***Scene capture***

The scene capture function lets you record a scene (a *scene* consists of a certain combination of effects, or certain 'look') and show that scene at any time.

There are three scene capture controls on the Control / Settings DMX channel:

- **Capture current scene** stores the currently displayed scene in the fixture's memory.
- **Captured scene playback = ON** sets the fixture to show the scene that is stored in memory if the fixture stops receiving a DMX signal.
- **Captured scene playback = OFF** disables the scene playback function: the fixture does not show the scene that is stored in memory.

If you capture a scene, the fixture keeps that scene in memory even if you cycle power off and on again.

## Effects

See ‘DMX protocol’ on page 34 for a full list of the DMX channels and values required to control the different effects.

### ***Shutter effect***

The electronic ‘shutter’ effect provides instant open and blackout, variable speed regular and random strobe.

### ***Dimmer***

Overall intensity can be adjusted 0-100% using smooth continuous electronic dimming with 16-bit control resolution.

### ***Custom colors***

The fixture offers an RGB color mixing interface with 16-bit resolution. Colors are obtained using RGBW LED output.

### ***Color wheel effect***

Besides color mixing, the ELP PAR features a virtual color wheel effect with 48 preset colors. The virtual color wheel also provides variable speed color scrolling and random colors.

Note that DMX commands sent on the virtual color wheel channel override DMX commands sent on individual RGB color channels. This means that if you want to use RGB color control on DMX channels 4 – 9, the color wheel effect on channel 10 must be set to a DMX value from 0 to 10 (open position).

### ***Color Temperature Control***

The ELP PAR’s CTC channel lets you vary the color temperature of the fixture’s white output from 1800 K to 12 850 K. The default color temperature is 6000 K (which corresponds to DMX value 118 on the CTC channel).

If the fixture cannot reach some low CTC values, it clips at the lowest achievable value (for example, DMX values 0-28 all give a color temperature of 1800 K).

Note that CTC is disabled if you put the fixture into raw mode.

### ***Zoom***

Zoom control via DMX lets you vary the field (one-tenth peak) angle from 5.6° to 57.6° and beam (half-peak) angle from 4.2° to 35.4°.

# RDM

The ELP PAR responds to the following RDM PIDs:

PID	Name	Description	GET	SET
0x0001	DISC_UNIQUE_BRANCH	Fixture discovery	N/A	N/A
0x0002	DISC_MUTE	Fixture discovery	N/A	N/A
0x0003	DISC_UN_MUTE	Fixture discovery	N/A	N/A
0x0020	QUEUED_MESSAGE	Get Queued Messages	Y	
0x0030	STATUS_MESSAGES	Get Status/Error Information	Y	
0x0031	STATUS_ID_DESCRIPTION	Status/Error Description	Y	
0x0032	CLEAR_STATUS_ID	Clear Status/Error Queue		Y
0x0050	SUPPORTED_PARAMETERS	Parameter discovery	Y	
0x0051	PARAMETER_DESCRIPTION	Parameter discovery	Y	
0x0060	DEVICE_INFO	Get basic info	Y	
0x0080	DEVICE_MODEL_DESCRIPTION	Product Name	Y	
0x0081	MANUFACTURER_LABEL	Manufacturer Name	Y	
0x0082	DEVICE_LABEL	User-Changeable Label	Y	Y
0x0090	FACTORY_DEFAULTS	Reset to factory defaults	Y	Y
0x00C0	SOFTWARE_VERSION_LABEL	Firmware version	Y	
0x00E0	DMX_PERSONALITY	DMX Mode	Y	Y
0x00E1	DMX_PERSONALITY_DESCRIPTION	DMX Mode Name	Y	
0x00F0	DMX_START_ADDRESS	DMX Start Address	Y	Y
0x0121	SLOT_DESCRIPTION	DMX Channel Description	Y	
0x0200	SENSOR_DEFINITION	Sensor Description	Y	
0x0201	SENSOR_VALUE	Sensor Value	Y	Y
0x0400	DEVICE_HOURS	Fixture Hours	Y	Y
0x0405	DEVICE_POWER_CYCLES	Fixture Power Cycles	Y	Y
0x0500	DISPLAY_INVERT	Flip Display	Y	Y
0x0501	DISPLAY_LEVEL	Display Intensity	Y	Y
0x1000	IDENTIFY_DEVICE	Highlight Fixture in rig	Y	Y
0x1001	RESET_DEVICE	Warm/Cold Reset		Y
0x1020	PERFORM_SELFTEST	Self test	Y	Y

0x1021	SELF_TEST_DESCRIPTION	Self test Description	Y	
0x8001	DMX_RESET	Enable/Disable Fixt. Off via DMX	Y	Y
0x8003	FIXTURE_ID	User-Changeable Fixture Number	Y	Y
0x8004	COLOR_MODE	Set Color Mode	Y	Y
0x8301	EFFECT_SPEED	Set Effects Speed	Y	Y
0x8308	DISPLAY_ERRORS_ENABLE	Show Errors on Display	Y	Y
0x8310	DIMMER_CURVE	Set Dimmer Curve	Y	Y
0x8312	DISPLAY_AUTO_OFF	Display Auto Off	Y	Y
0x8325	VIDEO_TRACKING	Video Tracking On/Off	Y	Y
0x8329	HIBERNATION_MODE	Enable/Disable Hibernation	Y	Y
0x832A	TUNGSTEN_MODE	Enable/Disable Tungsten Mode	Y	Y
0x8603	FAN_CLEAN	Fan Clean Mode	Y	Y
0x8604	FAN_MODE	Fan Mode	Y	Y
0x8700	SERIAL_NUMBER	Read Serial Number	Y	

## Maintenance



**Read ‘Safety information’ on page 4 before servicing the fixture.**

Refer any service operation not described in this user manual to a qualified service technician.

Disconnect the fixture from mains power and allow to cool completely before cleaning or servicing.

Service fixtures in an area where there is no risk of injury from falling parts, tools or other materials.

## Cleaning

Excessive dust, smoke fluid, and particle buildup degrades performance, causes overheating and will damage the fixture. Damage caused by inadequate cleaning or maintenance is not covered by the product warranty.

The cleaning of external optical lenses must be carried out periodically to optimize light output. Cleaning schedules for lighting fixtures vary greatly depending on the operating environment. It is therefore impossible to specify precise cleaning intervals for the fixture. Environmental factors that may result in a need for frequent cleaning include:

- Use of smoke or fog machines.
- High airflow rates (near air conditioning vents, for example).
- Presence of cigarette smoke.
- Airborne dust (from stage effects, building structures and fittings or the natural environment at outdoor events, for example).

If one or more of these factors is present, inspect fixtures within their first 100 hours of operation to see whether cleaning is necessary. Check again at frequent intervals. This procedure will allow you to assess cleaning requirements in your particular situation. If in doubt, consult your Martin dealer about a suitable maintenance schedule.

Use gentle pressure only when cleaning, and work in a clean, well-lit area. Do not use any product that contains solvents or abrasives, as these can cause surface damage.

To clean the fixture:

1. Disconnect the fixture from power and allow it to cool for at least 15 minutes.
2. Vacuum or gently blow away dust and loose particles from the outside of the fixture and the air vents with low-pressure compressed air.

3. Clean lenses by wiping gently with a soft, clean lint-free cloth moistened with a weak detergent solution. Do not rub the surface hard: lift particles off with a soft repeated press. Dry with a soft, clean, lint-free cloth or low-pressure compressed air. Remove stuck particles with an unscented tissue or cotton swab moistened with glass cleaner or distilled water.
4. Check that the fixture is dry before reapplying power.

## Uploading new firmware

**Important!** Do not switch the fixture off or disconnect the source of the firmware during an update, or the firmware will be corrupted.

You can check the currently installed firmware version in the INFORMATION menu. Firmware updates can be downloaded automatically from the Martin cloud using the Martin Companion software suite on a PC connected to the Internet.

Fixture information and settings are not affected when you upload new firmware to the fixture. All ELP PAR fixtures that are powered on and connected via a DMX link to the fixture that you update will also have their firmware updated.

If you update firmware to a newer version, check the ELP PAR area of [www.martin.com](http://www.martin.com) to see whether an updated version of this User Guide is available for the new firmware.

You need the following in order to install firmware:

- A Windows PC running the latest version of the Martin Companion software suite that is available for download from the Martin website at [www.martin.com](http://www.martin.com).
- The latest ELP PAR firmware files (Martin Companion automatically downloads these from the Martin fixture firmware cloud when you run it on a PC that is connected to the Internet).
- A Martin Companion Cable USB-DMX hardware interface (see “Accessories” on page 46). Note that you can install new firmware in multiple fixtures at the same time using the Martin Companion Cable.

To install the ELP PAR firmware using a Martin Companion Cable:

1. Apply power to the ELP PAR fixture(s) and allow it to boot
2. Connect the Martin Companion Cable's USB connector to a USB port on your PC. Connect the Martin Companion Cable's XLR connector to either the fixture's DMX IN connector or the DMX link.
3. Start the PC and launch Martin Companion. Check that the Martin Companion application correctly detects the Martin Companion Cable (a green dot should appear next to **USB Connected** in the top right-hand corner of the window).



4. Locate the latest ELP PAR firmware in Martin Companion (**Firmware** → **ELP** → **ELP PAR**).
5. Start the firmware update by clicking **Update Firmware** in Martin Companion. Do not disconnect the Martin Companion Cable or power off the fixture(s) until the upload is complete and the fixture(s) has successfully rebooted.
6. If you are updating multiple fixtures over a DMX link, check that they have all rebooted correctly.

## **Service and repairs**

There are no user-serviceable parts inside the fixture. Do not open the housing. The LED light source is not user-replaceable.

Refer any service or repair operation not described in this manual to an authorized Martin service technician. Do not try to carry out such an operation yourself, as doing so may present a health or safety risk. It may also cause damage or malfunction, and it may void your product warranty.

Installation, on-site service and maintenance can be provided worldwide by the Martin Professional Global Service organization and its approved agents, giving owners access to Martin's expertise and product knowledge in a partnership that will ensure the highest level of performance throughout the product's lifetime. Please contact your Martin supplier for details.

# DMX protocol

Channel	Value	Function	Fade type	De-fault
1	0-19	<b>Strobe and shutter effects</b> Shutter closed Shutter open Strobe, slow → fast Shutter open Random strobe, slow → fast	Snap	30
	20-49			
	50-200			
	201-210			
	211-255			
2	0-65535	Dimming coarse 0→100%	Fade	0
3		Dimming fine		
4	0-65535	Red coarse 0→100%	Fade	0
5		Red fine		
6	0-65535	Green coarse 0→100%	Fade	0
7		Green fine		
8	0-65535	Blue coarse 0→100%	Fade	0
9		Blue fine		
10	0-28	<b>CTC</b> 1800 K ... 6000 K ... 6500 K ... 12 850 K	Fade	118
	...			
	118			
	...			
	255			
11	0-10	<b>Color wheel effect (color presets)</b> Open (white) Moroccan Pink (LEE 790) Pink (LEE 157) Special Rose Pink (LEE 332) Follies Pink (LEE 328) Fuchsia Pink (LEE 345) Surprise Pink (LEE 194) Congo Blue (LEE 181) Tokyo Blue (LEE 071) Deep Blue (LEE 120) Just Blue (LEE 079) Medium Blue (LEE 132)	Snap	0
	11-12			
	13-14			
	15-16			
	17-18			
	19-20			
	21-22			
	23-24			
	25-26			
	27-28			
	29-30			
	31-32			

Channel	Value	Function	Fade type	De-fault
11 (contd.)	33-34	Double CT Blue (LEE 200)		
	35-36	Slate Blue (LEE 161)		
	37-38	Full CT Blue (LEE 201)		
	39-40	Half CT Blue (LEE 202)		
	41-42	Steel Blue (LEE 117)		
	43-44	Lighter Blue (LEE 353)		
	45-46	Light Blue (LEE 118)		
	47-48	Medium Blue Green (LEE 116)		
	49-50	Dark Green (LEE 124)		
	51-52	Primary Green (LEE 139)		
	53-54	Moss Green (LEE 089)		
	55-56	Fern Green (LEE 122)		
	57-58	Jas Green (LEE 738)		
	59-60	Lime Green (LEE 088)		
	61-62	Spring Yellow (LEE 100)		
	63-64	Deep Amber (LEE 104)		
	65-66	Chrome Orange (LEE 179)		
	67-68	Orange (LEE 105)		
	69-70	Gold Amber (LEE 021)		
	71-72	Millennium Gold (LEE 778)		
	73-74	Deep Golden Amber (LEE 135)		
	75-76	Flame Red (LEE 164)		
	77-78	Red Magenta (LEE 113)		
	79-80	Medium Lavender (LEE 343)		
	81-82	Pure White (White LEDs only)		
	83-84	Pure Red (Red LEDs only)		
	85-86	Pure Yellow (Red+Green LEDs only)		
	87-88	Pure Green (Green LEDs only)		
	89-90	Pure Cyan (Green+Blue LEDs only)		
	91-92	Pure Blue (Blue LEDs only)		
	93-94	Pure Magenta (Blue+Red LEDs only)		
	95-96	Peacock Blue (LEE 115)		
97-98	Dark Lavender (LEE 180)			
99-100	Double CT Orange (LEE 287)			
101-102	Full CT Orange (LEE 204)			
103-104	Half CT Orange (LEE 205)			
105-106	Deep Straw (LEE 015)			
107 - 190	<i>No function</i>			
	<b>Continuous rotation (color scroll)</b>			
191 - 214	Ascending, fast → slow			
215 - 219	Stop (at current position)			
220 - 243	Descending, slow → fast			

Channel	Value	Function	Fade type	De-fault
11 (contd.)	244 - 247 248 - 251 252 - 255	<b>Random colors</b> Random color, fast Random color, medium Random color, slow	Snap	0
12	0-65535	Zoom narrow → wide coarse 0→100%	Fade	32768
13		Zoom narrow → wide fine		
14	0 - 9 10 - 14 15 - 16 17 18-22 23 24 25 26 27-37 38 39 40 41-51 52 53 54  55 56  57-60 61 62 63 - 71 72 73 74 75 76 77 - 99	<b>Control / Settings</b> No function (disables calibration) – 5 s. Reset fixture – 5 s. <i>No function</i> Reset beam – 5 s. <i>No function</i> Linear dimming curve – 1 s. <b>Square law dimming curve</b> – 1 s. Inverse square law dimming curve – 1 s. S-curve dimming curve – 1 s. <i>No function</i> <b>Extended color mode</b> – 1 s. Calibrated color mode – 1 s. Raw color mode – 1 s. <i>No function</i> Display ON – 1 s. Display OFF – 1 s. <b>Regulated fan speed, fixed intensity</b> – 1 s. Full fan speed, regulated intensity – 1 s. Theater mode: reduced max. intensity, low fan speed – 1 s. <i>No function</i> Hibernation mode = ON – 5 s. <b>Hibernation mode = OFF</b> – 5 s. <i>No function</i> Tungsten emulation = ON – 1 s. <b>Tungsten emulation = OFF</b> – 1 s. Capture current scene – 5 s. Captured scene playback = ON – 5 s. <b>Captured scene playback = OFF</b> – 5 s. <i>No function</i>	Snap	0

Channel	Value	Function	Fade type	De- fault
14	100	Enable calibration – 5 s.		
(contd.)	101	<i>No function</i>		
	102	Store dimmer calibration – 5 s.		
	103 - 113	<i>No function</i>		
	114	Store zoom calibration – 5 s.		
	115 - 198	<i>No function</i>		
	199	Reset ALL calibration settings to factory defaults – 5 s.		
	200 - 255	<i>No function</i>		

## Control menus

To access the control menus, press the MENU button. Use the UP and DOWN buttons to navigate the menus. Select any required menu option using the ENTER button. For more information, see 'Using the control menus' on page 18.

Default fixture settings are shown in **bold**.

Menu	Setting/value	Notes
<b>DMX SETUP</b>		
DMX ADDRESS	<b>001</b> –499	Set fixture's DMX address
<b>PERSONALITY</b>		
TUNGSTEN EMULATOR	ON	Activate tungsten incandescent lamp emulation mode
	<b>OFF</b>	
COLOR MODE	<b>EXTENDED COLOR</b>	Calibrated white, uncalibrated color
	CALIBRATED	Calibrated white, calibrated color
	RAW UNCALIBRATED	Raw: uncalibrated white, uncalibrated color
DIMMER CURVE	LINEAR	Dimming curve options
	<b>SQUARE LAW</b>	
	INV SQ LAW	
	S-CURVE	
DIMMING SPEED	<b>FAST</b>	Optimize dimmer for speed
	SLOW	Optimize dimmer for smoothness
NO DATA MODE	BLACKOUT	Set fixture behavior if DMX signal stops: blackout or hold current effect
	<b>HOLD</b>	
COOLING MODE	<b>REGULATED FANS</b>	Fans normal, temperature-regulated
	THEATER MODE	Fans low-noise, temperature-regulated (reduced max. output)
	FULL	Fans constant full speed

DISPLAY	DISPLAY ROTATION	<b>NORMAL</b>	Normal orientation
		ROTATE 180°	Inverted orientation
	DISPLAY INTENSITY	10 - <b>100</b>	Control panel display intensity in %
	TEMPERATURE UNIT	°C	All temperature readouts in Celsius
°F		All temperature readouts in Fahrenheit	
<b>DEFAULT SETTINGS</b>			
FACTORY DEFAULT	<b>NO</b>	Return all fixture settings except calibration to factory defaults	
	YES		
<b>FIXTURE TEST</b>			
TEST ALL	TESTING	Automatic test of all effects including dimming	
TEST DIMMER	DIMMER	Manually test LED groups only*	
TEST EFFECTS	RED	Manually test individual effects*  <i>COLOR = Virtual color wheel</i>	
	GREEN		
	BLUE		
	CTC		
	COLOR		
	ZOOM		
<b>INFORMATION</b>			
POWER ON TIME	xxxxH	Display hours fixture powered on since manufacture	
LED HOURS	xxxxH	Display hours LEDs powered on since manufacture	
SW VERSION	Vx.x.x	Display currently installed firmware version	
FIXTURE ID	0 - 9999	Display a user-settable 4-digit fixture ID number	
RDM UID	xxxxxxxxxxxx	Display the fixture's unique RDM ID number	

\* Use UP & DOWN to scroll through LED groups or scroll through effects and pause test, press ENTER to start test. Press MENU to exit test.

TEMPERATURES	LED / BASE	Display temperatures of all PCBs and the integrated PSU	
FAN SPEED	LED / PSU	Display speeds in RPM of all cooling fans including the PSU cooling fan	
<b>DMX LIVE</b>			
STROBE	0 - 255	Scroll to display DMX values currently being received on each DMX channel from Strobe channel to Control / Settings channel	
DIMMER	0 - 255		
DIMMER FINE	0 - 255		
...	...		
ZOOM FINE	0 - 255		
FUNCTION	0 - 255		
<b>MANUAL CONTROL</b>			
RESET	ALL	NO	Reset entire fixture
		YES	
	EFFECTS	NO	Reset effects only
		YES	
STROBE	0 - 255	Manually send DMX values on each channel from Strobe channel to Zoom fine control channel	
DIMMER	0 - 255		
DIMMER FINE	0 - 255		
...	...		
ZOOM FINE	0 - 255		
<b>SERVICE</b>			
CALIBRATION	DIMMER	0 - 255	Calibrate overall dimming and RGB colors
	RED	0 - 255	
	GREEN	0 - 255	
	BLUE	0 - 255	
	CTC	0 - 255	Adjust 6000 K center point
	CTC Tint	0 - 255	Adjust green/ magenta tint
	RAW CTC	0 - 255	Adjust 6000 K center point
	RAW CTC Tint	0 - 255	Adjust green/ magenta tint
	ZOOM	-128 - 127	Calibrate zoom
	LOAD DEFAULTS	LOAD	Load the factory default calibration settings



		SAVE	Save current custom calibration settings. <b>Important! See note below</b>
	SAVE SETTING	SAVE	Replace factory default calibration settings with custom values or zero values. <b>Important! See note below</b>
	CLEAR ALL VALUES	RESTORE	Reset all calibration values to zero. <b>Important! See note below</b>

### Important note

- LOAD DEFAULTS → SAVE stores any custom calibration values that you have created in the CALIBRATION menu. The fixture will keep using these values even when the fixture power is cycled off and on.
- LOAD DEFAULTS → LOAD loads the original factory default calibration values (unless these have been overwritten or erased – see below)
- CLEAR ALL VALUES → RESTORE erases all calibration settings – both custom settings and the original factory settings. **Important! If you use this command you will need to fully recalibrate the fixture.**
- **Important! SAVE SETTING → SAVE permanently overwrites the original factory settings with either the custom settings created using LOAD DEFAULTS → SAVE or the zero values created using CLEAR ALL VALUES → RESTORE. The SAVE SETTING → SAVE command should normally be used by Martin Service only!**

# Troubleshooting

This section describes a few common problems that may occur during operation and provides some suggestions for easy troubleshooting:

Symptom	Potential cause	Remedies
No light from fixture or fans not working.	Power supply issue such as faulty connector, damaged cable or internal fault.	Ensure that the mains supply is connected and supplying power to the fixture. Check all power connections and cables.  Contact your Martin authorized distributor or service center for assistance.
One of the control channels is unresponsive or only responds intermittently.	DMX setup or DMX link fault.  Faulty cable connection.  Damaged zoom step motor.	See next section.  Contact your Martin authorized distributor or service center for assistance.
Fixture does not respond to DMX control.	Incorrect DMX addressing.  Fault on DMX link due to damaged connector or cable, or potential interference from proximity to a high-voltage installation.	Ensure that fixture's DMX address matches address set on DMX control device.  Check all DMX cables and connections.  Ensure that DMX link is terminated.  Check that all components on DMX link use standard DMX polarity.  Attempt to control the fixture with another DMX control device.  Move or shield link if it is close to an unshielded high-voltage installation.

# Dimensions

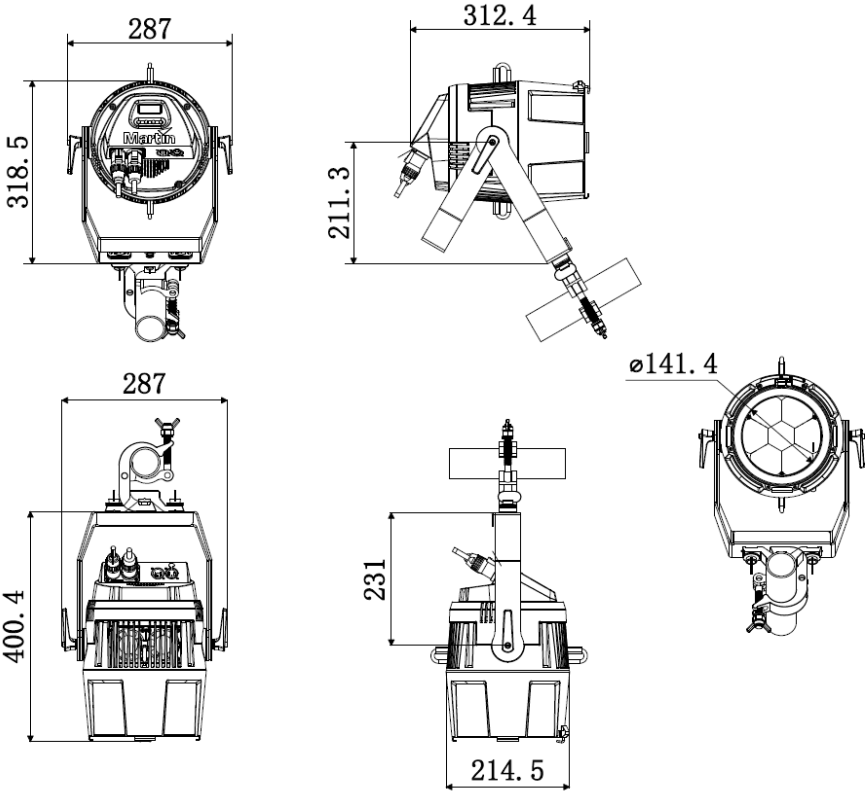

All dimensions are in millimeters

# Specifications

## Physical

Dimensions incl. bracket (LxWxH) ... 312x287x401 mm (12.3x11.3x15.8 in.)  
Weight ..... 7.8 kg (17.2 lbs.)

## Dynamic Effects

Color mixing ..... RGBW  
Color presets ..... 48 color presets, virtual color wheel effects  
Color temperature ..... Variable 1800 – 12 850 K  
Electronic dimming ..... 0 - 100%, four dimming curve options  
Strobe and pulse effects ..... Variable speed and action, random strobe  
Electronic 'shutter' effect ..... Instant open and blackout  
Zoom ..... Motorized

## Control and Programming

Control options ..... DMX, RDM  
DMX channels ..... 14  
16-bit fine control ..... Dimming, RGB, Zoom  
LED color management modes ..... Raw, extended and calibrated  
DMX address setting ..... Control panel with OLED display  
DMX compliance ..... USITT DMX512-A  
RDM compliance ..... ANSI/ESTA E1.20

## Optics

Light source ..... 7 x 40 W RGBW Osram LEDs  
Minimum LED lifetime ..... 50 000 hours (to >70% luminous output)\*  
Beam angle ..... 4.2 – 35.4°  
Field angle ..... 5.6 – 57.6°  
Cutoff angle ..... 6.2 – 65.1°

*\*Figure obtained under manufacturer's test conditions*

## Construction

Filter mount ..... 191 x 191 mm (7.5 x 7.5 in.)  
Color ..... Black  
Housing ..... Aluminum and composite  
Protection rating ..... IP 20

## Installation

Mounting points ..... Adjustable bracket, surface or truss  
mount (fits Martin Omega Bracket)  
Location ..... Not for household use, indoor use in dry location only  
Orientation ..... Any  
Minimum distance to illuminated surfaces ..... 1 m (3.3 ft.)  
Minimum distance to combustible material ..... 0.5 m (1.7 ft.)  
Minimum clearance around fans and vents ..... 0.5 m (1.7 ft.)

## Connections

AC power input.....	Neutrik PowerCON TRUE1 TOP
AC power throughput .....	Neutrik PowerCON TRUE1 TOP
DMX data in/out.....	Neutrik 5-pin locking XLR

## Electrical

AC power.....	100-240 V nominal, 50/60 Hz
Typical power consumption.....	300 W
Typical half-cycle RMS inrush current at 240 VAC .....	8.7 A
Power supply unit.....	Auto-ranging electronic switch mode

## Maximum power and current

100-120 V, 60 Hz .....	3.0 A, 320 W, Power factor 0.99
220-240 V, 50 Hz .....	1.7 A, 320 W, Power factor 0.94

*\*Measurements made at nominal voltage with all LEDs at full intensity.  
Allow for a deviation of +/- 10%.*

## Thermal

Maximum surface temperature .....	65° C (149° F)
Cooling .....	Forced air (temperature regulated, low noise)
Maximum ambient temperature (Ta max.).....	40° C (104° F)
Minimum ambient temperature (Ta min).....	-10° C (32° F)
Total heat dissipation* .....	1170 BTU/hr.

*\*Calculated, +/- 10%, at full intensity, full white*

## Approvals



Global CB Certification/IECEE .....	IEC 60598-2-17 (IEC 60598-1)
EU safety.....	EN 60598-2-17 (EN 60598-1), EN 62471, EN 62493
EU EMC .....	EN 55015, EN 55032, EN 55035, EN 61000-3-2, EN 61000-3-3, EN 61547
US safety.....	UL 1573
US EMC .....	FCC Part 15 Class B
Canadian safety .....	CSA C22.2 No. 166
Canadian EMC .....	ICES-003 Class B, ICES-005 Class B
Australia/NZ.....	RCM
United Kingdom.....	UKCA

## Included Items

Adjustable mounting bracket

## Accessories

### **Power input cables, 16 A**

Power Input Cable, H07RN-F, 2.5 mm<sup>2</sup>, bare ends to  
TRUE1 NAC3FX-W (female), 1.5 m (4.9 ft.) ..... P/N 91611797

Power Input Cable, H07RN-F, 2.5 mm<sup>2</sup>, bare ends to  
TRUE1 NAC3FX-W (female), 5 m (16.4 ft.) ..... P/N 91611786

Power Input Cable, SJOOW, 12 AWG, bare ends to  
TRUE1 NAC3FX-W (female), 1.5 m (4.9 ft.) ..... P/N 91610173

Power Input Cable, SJOOW, 12 AWG, bare ends to  
TRUE1 NAC3FX-W (female), 5 m (16.4 ft.) ..... P/N 91610174

### **Power relay cables, 16 A, for relaying power to fixtures in chains**

Power Relay Cable, H07RN-F, 2.5 mm<sup>2</sup>,  
TRUE1 to TRUE1, 0.45 m (1.5 ft.) ..... P/N 91611784

Power Relay Cable, H07RN-F, 2.5 mm<sup>2</sup>,  
TRUE1 to TRUE1, 1.2 m (3.9 ft.) ..... P/N 91611785

Power Relay Cable, H07RN-F, 2.5 mm<sup>2</sup>,  
TRUE1 to TRUE1, 2.5 m (8.2 ft.) ..... P/N 91611796

Power Relay Cable, SJOOW, 12 AWG,  
TRUE1 to TRUE1, 0.45 m (1.5 ft.) ..... P/N 91610170

Power Relay Cable, SJOOW, 12 AWG,  
TRUE1 to TRUE1, 1.2 m (3.9 ft.) ..... P/N 91610171

Power Relay Cable, SJOOW, 12 AWG,  
TRUE1 to TRUE1, 2.5 m (8.2 ft.) ..... P/N 91610172

### **Power connectors**

Cable Connector, Neutrik powerCON TRUE1  
NAC3FX-W TOP (female) ..... P/N 91611789HU

Cable Connector, Neutrik powerCON TRUE1  
NAC3MX-W TOP (male) ..... P/N 91611788HU

### **Installation hardware**

Martin Omega bracket for rigging clamp attachment ..... P/N 91602001

Half-coupler clamp ..... P/N 91602005

G-clamp (suspension vertically downwards only) ..... P/N 91602003

Quick-trigger clamp (suspension vertically downwards only) . P/N 91602007

Safety Cable, SWL 60 kg, BGV C1 / DGUV 17, black ..... P/N 91604006

Safety Cable, SWL 60 kg, BGV C1 / DGUV 17, silver ..... P/N 91604007

## Related Items

Martin Companion software suite (incl. firmware uploader) .....	Free download from <a href="http://www.martin.com">www.martin.com</a>
Martin Companion Cable USB/DMX hardware interface .....	P/N 91616091

## Ordering Information

ELP PAR in cardboard box .....	P/N 90800000
--------------------------------	--------------

*Specifications are subject to change without notice. For the latest product specifications, see [www.martin.com](http://www.martin.com)*

## Supplier's Declaration of Conformity

Harman Professional, Inc. have issued an FCC Supplier's Declaration of Conformity for this product. The Declaration of Conformity is available for download from the ELP PAR area of the Martin website at [www.martin.com](http://www.martin.com)

## FCC compliance statement

This equipment has been tested and found to comply with the limits for a Class B digital device, pursuant to part 15 of the FCC Rules. These limits are designed to provide reasonable protection against harmful interference in a residential installation. This equipment generates, uses and can radiate radio frequency energy and, if not installed and used in accordance with the instructions, may cause harmful interference to radio communications. However, there is no guarantee that interference will not occur in a particular installation. If this equipment does cause harmful interference to radio or television reception, which can be determined by turning the equipment off and on, the user is encouraged to try to correct the interference by one or more of the following measures:

- Reorient or relocate the receiving antenna.
- Increase the separation between the equipment and receiver.
- Connect the equipment into an outlet on a circuit different from that to which the receiver is connected.
- Consult the dealer or an experienced radio/TV technician for help.



#### Disposing of this product

Martin® products are supplied in compliance with Directive 2012/19/EC of the European Parliament and of the Council of the European Union on WEEE (Waste Electrical and Electronic Equipment), where applicable. Help preserve the environment! Ensure that this product is recycled at the end of its life. Your supplier can give details of local arrangements for the disposal of RUSH by Martin products









**Martin**<sup>®</sup>  
by HARMAN

[www.martin.com](http://www.martin.com)