

Model 5304 Intercom Station

User Guide

Issue 1, February 2022

This User Guide is applicable for serial numbers
M5304-00151 and later with Application Firmware 1.04 and later

Copyright © 2022 by Studio Technologies, Inc., all rights reserved
studio-tech.com

This page intentionally left blank.

Table of Contents

Revision History	4
Introduction.....	5
Getting Started	8
Dante Configuration	11
Model 5304 Configuration	12
Operation.....	17
Technical Notes.....	21
Specifications	24
Appendix A–STcontroller Default Configuration Values.....	26
Appendix B– Graphical Description of the Installation Kit for Panel-Cutout or Surface-Mounting Use (Order Code RMBK-10).....	27
Appendix C–Graphical Description of Left- or Right-Side Rack-Mount Installation Kit for One “1/2- Rack” Unit (Order Code RMBK-11).....	28
Appendix D–Graphical Description of Rack-Mount Installation Kit for Two “1/2- Rack” Units (Order Code RMBK-12).....	29
Appendix E–Graphical Description of Center Rack-Mount Installation Kit for One “1/2- Rack” Unit (Order Code RMBK-13).....	30

Revision History

Issue 1, February 2022:

- Initial release.

Introduction

The Model 5304 Intercom Station provides four independent talk and listen channels that are compatible with Dante® audio-over-Ethernet networks. An extensive range of configurable parameters allow the performance to be optimized for numerous intercom applications. The unit is designed to serve as a user station for production and support personnel in applications including on-air television broadcasting, live events, theater, industrial, aerospace, house of worship, and corporate AV. The Model 5304's four channels can be part of a virtual "party-line" intercom system created with other compatible devices. The unit's lightweight aluminum enclosure is intended for desktop or tabletop use. Optional mounting kits allow one or two Model 5304 units to be mounted in one space (1U) of a standard 19-inch rack enclosure.

Over a standard IP network, multiple Model 5304 units can become part of a party-line (PL) intercom application with help from an external Dante-enabled audio device such as the Studio Technologies' Model 5421 or Model 5422A Dante Intercom Audio Engine unit. Model 5304 units can also be deployed in conjunction with Dante-compliant matrix interface systems. The Model 5304's range of resources makes it possible to use units locally or as part of a REMI or "At-Home" implementation.

Only a headset and a Power-over-Ethernet (PoE) connection are required for operation. Key user features can be easily configured using the STcontroller

software application. Configurable parameters include electret microphone powering, microphone preamplifier gain, talk and auxiliary button operation, call signal support, headphone channel assignment, and remote control inputs. Specific user features include integrated sidetone operation, remote mic kill ("talk off"), LED display intensity, and microphone audio level display. The wide range of capabilities, along with the excellent audio quality provided by the digital audio signal path, offers a unique and highly effective user experience.

Set up and configuration of the Model 5304 is simple. An RJ45 jack is used to interconnect with a standard twisted-pair Ethernet port associated with a local-area network (LAN). This connection provides both power and bidirectional digital audio. Two LEDs provide an indication of the Ethernet connection's status. A broadcast or intercom-style stereo or monaural headset with a dynamic or electret (DC-powered) microphone interfaces with the unit using a 5-pin XLR connector. A 3-conductor 3.5 mm jack allows connection of two external switches or contact closures to activate two selected talk channels.

The STcontroller software application is used to select the unit's operating parameters. STcontroller is available, free of charge, from the Studio Technologies' website. Versions are available that are compatible with the Windows® and macOS® operating systems. STcontroller is a fast and simple means of configuring, revising, saving, and loading a unit's operating parameters.



Figure 1. Model 5304 Intercom Station front and back views

Dante Audio-over-Ethernet

Audio data is sent to and received from the Model 5304 using the Dante audio-over-Ethernet media networking technology. As a Dante-compliant device, the Model 5304's four Dante transmitter (output) and four Dante receiver (input) audio channels can be assigned (routed or "subscribed") with other devices using the Dante Controller software application. The Dante transmitter (output) and receiver (input) channels are limited to supporting four Dante flows, two in each direction. The Dante digital audio's bit depth is up to 24 with a sample rate of 48 kHz.

The Model 5304 is compliant with the AES67 interoperability standard. In addition, the unit is compatible with the Dante Domain Manager™ (DDM) software application.

Audio Quality

The Model 5304's audio quality is completely "pro." A low-noise, wide dynamic-range microphone pre-amplifier and associated analog dynamics controller (compressor) circuit ensures that microphone audio quality is preserved and minimizes the chance of signal overload. If desired, DC power can be enabled to support electret microphones. The output of the microphone preamp and compressor is routed to an analog-to-digital conversion (ADC) section that supports a sample rate of 48 kHz with a bit depth of up to 24. The audio signal, now in the digital domain, travels through the unit's 32-bit microcontroller integrated circuit and on to the Dante interface section where it is packetized and prepared for transport over Ethernet.

The microphone audio signal can also be routed to the headphone output whenever one or more of the "talk" channels are active. This "sidetone" function supports the user by allowing them to monitor the audio associated with their own microphone. The level of the sidetone signal can be configured from among five choices as well as being disabled.

Audio signals arrive in the Model 5304 by way of four Dante receiver (input) channels. These audio signals pass into the Model 5304's microcontroller integrated circuit where channel routing, headphone level control, and sidetone functionality are performed within the digital domain. Five rotary encoders allow the level of each input channel, and the overall level,

to be adjusted. The mix of audio signals destined for the 2-channel headphone output is sent to a high-performance digital-to-analog converter (DAC) integrated circuit and then on to robust driver circuitry. High signal levels can be provided to a variety of headsets, headphones, and earpieces.

User Controls and Indicators

The Model 5304's front panel includes five rotary controls (multi-step "encoders"), five pushbutton switches, and an 8-segment multipurpose display. Four of the encoders are used to adjust the listen level of the four Dante receiver (input) audio channels. They are also used to fully mute an input as well as activating a channel "solo" listen function. Using RGB (red-green-blue) LEDs, the knob associated with each encoder can illuminate, displaying three colors to represent the approximate level of the audio input signal, lighting purple if the channel is fully muted, or flashing or lighting orange when an in-band (20 kHz tone) call signal is detected. An additional rotary encoder is used to control the overall audio level of the signals being sent to the headset outputs. It can also be used to fully mute the headphone output channels.

The four pushbutton switches are used to enable the routing of microphone audio to the Dante transmitter (output) "talk" audio channels. Configuration choices allow the operation of the four talk buttons to be optimized to meet an application's needs. Their action can be independently configured, as well as selected to send only voice audio, or to send both voice audio and an 18 kHz sine wave tone. This latter capability is specifically provided for supporting REMI/AT-Home or other specialized applications. A fifth pushbutton switch, labeled AUX, can be configured to provide either an "all talk" function or to serve as a call enable button.

The multipurpose display utilizes eight bi-color LEDs to provide a range of Model 5304 performance indications. It can serve as an audio level meter, providing a real-time indication of the microphone signal as it is sent to one or more of the active "talk" channels. It will also provide an indication of the setting of the rotary encoders. The multipurpose display will also indicate when a configuration choice has been made or when the Dante identification function has been received.

Call Signaling Support

Call functions allow Model 5304 users to send and receive channel-specific visual alert signals. Using 20 kHz tones, the call signals are sent as part of the audio channels (“in band”) allowing interoperability between multiple Model 5304 units and other products from Studio Technologies. This call signaling method is also compatible with analog legacy party-line intercom systems. Call signals can be useful to indicate to users that they are needed “on headset” or that they should be actively listening to an intercom channel. The call function can also be used to provide real-time cues to production personnel during the running of live events.

The auxiliary pushbutton switch, located on the right side of the Model 5304’s front panel, can be configured to serve as a call button. In this way, any active talk channel will include a 20 kHz call tone when the auxiliary button is pressed. A call signal present on any of the four Dante receiver (input) channels can be detected and displayed. To optimize call operation for specific applications, a configuration choice allows the way in which the Model 5304 will light its LED indicators when call signals are received.

Configuration Flexibility

A highlight of the Model 5304 is its ability to be easily configured to meet the needs of specific users and applications. All configuration choices are made using the STcontroller software application that communicates with the Model 5304 by way of the unit’s Ethernet network connection. Configurable parameters include microphone power and preamplifier gain, sidetone audio operation, signal present indication, microphone level display, talk button operation, call indication, remote control inputs, and headphone monitoring.

The microphone input can be selected for compatibility with dynamic or electret microphones. The gain of the microphone preamplifier can be selected from among five choices. These selections allow compatibility with a variety of microphones that are part of broadcast and intercom headsets.

A unique Model 5304 feature is the ability to individually configure the way that each of the four talk pushbutton switches function; four choices are available. For standard intercom user station operation, Push to Talk, Tap to Latch, or Push to Talk/Tap to Latch

operation can be selected. For situations where only monitoring of an intercom channel is desired the Disabled mode is available. Configuration choices allow the two remote control inputs to be individually assigned to mimic the action of any one of the four intercom talk buttons or the auxiliary button.

Four audio channels arrive via Dante and are destined for the 2-channel headphone output. Each input source can be independently routed to the left headphone channel, right headphone channel, or both the left and right headphone channels. This flexibility allows a variety of listening environments to be created, including stereo, single-channel monaural, and dual-channel monaural. As previously described, a rotary encoder is used to control the audio level associated with each Dante receiver (input) channel. In addition, a fifth rotary encoder allows the overall headphone level to be controlled.

Ethernet Data and PoE

The Model 5304 connects to a Ethernet local-area network (LAN) using a standard 100 Mb/s twisted-pair Ethernet interface. The physical interconnection is made by way of an RJ45 jack. Two LEDs display the status of the network connection.

The Model 5304’s operating power is provided by way of the Ethernet interface using the 802.3af Power-over-Ethernet (PoE) standard. This allows fast and efficient interconnection with the associated data network. To support PoE power management, the Model 5304’s PoE interface reports to the power sourcing equipment (PSE) that it’s a class 2 (low power) device.

Future Capabilities and Firmware Updating

The Model 5304 was designed such that its capabilities and performance can be easily enhanced in the future. A USB connector, located on the unit’s back panel, allows the application firmware (embedded software) to be updated using a standard USB flash drive. The Model 5304 uses an UltimoX4™ integrated circuit from Audinate to implement its Dante interface. The firmware in this integrated circuit can be updated via the Ethernet connection, helping to ensure that its capabilities remain up to date.

Deployment

The Model 5304 is ready, “out of the box,” for deployment on a desk, table, or other flat surface. Its compact enclosure is essentially “½-rack” wide and one rack space high. The RMBK-10 installation kit, purchased as an option, allows one unit to be mounted in a panel cutout or on a wall surface. Three other installation kits, also purchased as options, allow one or two Model 5304 units to be mounted in one space (1U) of a standard 19-inch rack. The RMBK-11 allows one Model 5304 unit to be mounted on the left or right side of a single rack space. The RMBK-12 allows two Model 5304 units to be mounted in a single rack space. The RMBK-12 also allows a Model 5304 to be mounted with any other compatible Studio Technologies’ unit, including the popular Model 5421 Dante Intercom Engine. Finally, the RMBK-13 allows one Model 5304 to be mounted in the center of a single rack space.

Getting Started

In this section, a location will be selected for the Model 5304 Intercom Station. If desired, an optional installation kit will be used to mount a Model 5304 unit into a panel cutout, wall surface, or equipment rack. Signal interconnections can be made using the unit’s three connectors, two on the back and one on the front. An Ethernet data connection with Power-over-Ethernet (PoE) capability will be made using a standard RJ45 patch cable. Some applications will use the 3-conductor 3.5 mm jack located on the back panel to access the Model 5304’s two remote control inputs. A dual-channel or single-channel (dual- or single-ear) headset will be connected using a cable-mounted 5-pin male XLR connector.

What’s Included

Included in the shipping carton are a Model 5304 Intercom Station and instructions on how to obtain an electronic copy of this guide. As a device that is Power-over-Ethernet (PoE) powered, no external power source is provided. In most applications an Ethernet switch with the required PoE capability will be utilized. An optional installation kit allows a Model 5304 to be mounted in a rectangular opening in a tabletop or attached to a flat surface. If one or two Model 5304 units are going to be mounted in a 19-inch equipment rack then having one of the optional rack-

mount installation kits is required. If an installation kit was purchased it would typically have been shipped in a separate carton.

Locating the Model 5304

The Model 5304’s location will depend on where the user needs access to it. The Model 5304 is shipped as a self-contained “throw down” unit suitable for portable use or placement in a semi-permanent location. Installed on the bottom of the chassis are screw-affixed “bump on” protectors (also known as rubber “feet”). These are useful if the unit is going to be placed on a surface where scratching of either the Model 5304’s enclosure or the surface material could take place. However, if applicable the “feet” can be removed when installation in a panel cutout, wall mount, or rack enclosure is going to be performed.

Once the unit’s location has been established its twisted-pair Ethernet cabling must be within 100-meters (325-feet) of the Ethernet port on the associated PoE network switch. This overall length limit can be overcome by using a fiber-optic interconnection between the Model 5304-related PoE-supporting Ethernet switch and another Ethernet switch that’s part of the application’s local-area-network (LAN). With fiber interconnects there’s no reason why a Dante-supported LAN can’t be distributed over many miles or kilometers.

Panel Cutout or Surface Mounting One Model 5304 Unit

Installation kit RMBK-10 allows one Model 5304 to be mounted in a panel cutout or onto a flat surface. The kit contains two standard-length brackets and four 6-32 thread-pitch Phillips-head machine screws. Refer to Appendix B for a visual explanation.

Get ready to install the kit by first removing the four machine screws and associated “bump on” protectors from the bottom of the Model 5304’s chassis. They are removed using a #1 Phillips screwdriver. Store the four machine screws and four “bump on” protectors for possible later use.

To prepare the unit to mount in a cutout or other opening in a panel, use a #2 Phillips screwdriver and two 6-32 machine screws to attach one of the standard-length brackets onto the left side (when viewed from the front) of the Model 5304’s enclosure. Orient

the standard-length bracket such that its front is parallel to the Model 5304's front panel. The screws will mate with the threaded fasteners that can be seen on the side of the Model 5304's enclosure, near the front of the unit. Using two additional 6-32 machine screws, attach the other standard-length bracket onto the right side of the Model 5304's enclosure.

Once the two standard-length brackets have been installed the Model 5304 will be ready to be mounted into an opening. Secure the unit into the top left and right edges of the opening using two mounting screws per side.

To prepare the unit to be mounted onto a flat surface simply requires the standard-length brackets be attached to the Model 5304 at 90 degrees from how they were mounted for use in a panel cutout. Use a #2 Phillips screwdriver and two 6-32 machine screws to attach one of the standard-length brackets onto the left side (when viewed from the front) of the enclosure. Orient the bracket such that its front is parallel with the top surface of the Model 5304's enclosure. The screws will mate with the threaded fasteners that can be seen on the side of the Model 5304's enclosure, near the front of the unit. Following the same orientation, use two additional 6-32 machine screws to attach the other standard-length bracket onto the right side of the Model 5304's enclosure.

Once the two standard-length brackets have been installed the Model 5304 will be ready to be mounted onto a flat surface. Secure the unit to the surface using two mounting screws per side.

Left- or Right-Side Rack Mounting One Model 5304 Unit

Installation kit RMBK-11 allows one Model 5304 to be mounted in the left or right side of one space (1U) of a standard 19-inch rack enclosure. The kit contains one standard-length bracket, one long-length bracket, and four 6-32 thread-pitch Phillips-head machine screws. Refer to Appendix C for a visual explanation.

Get ready to install the kit by removing the four machine screws and associated "bump on" protectors from the bottom of the Model 5304's chassis. They are removed using a #1 Phillips screwdriver. Store the four machine screws and four "bump on" protectors for possible later use.

To prepare the unit to mount in the left side of a rack enclosure, use a #2 Phillips screwdriver and two 6-32 machine screws to attach the standard-length bracket onto the left side (when viewed from the front) of the enclosure. The screws will mate with the threaded fasteners that can be seen on the side of the Model 5304's enclosure, near the front of the unit. Using two additional 6-32 machine screws, attach the long-length bracket onto the right side of the Model 5304's enclosure.

To prepare the unit to mount in the right side of a rack enclosure, use a #2 Phillips screwdriver and two 6-32 machine screws to attach the long-length bracket onto the left side of the enclosure. Using two additional 6-32 machine screws, attach the standard-length bracket onto the right side of the Model 5304's enclosure.

Once the standard-length and long-length brackets have been installed the Model 5304 will be ready to be mounted into the designated equipment rack. One space (1U or 1.75 vertical inches) in a standard 19-inch equipment rack is required. Secure the unit into the equipment rack using two mounting screws per side.

Rack-Mounting Two Model 5304 Units

Installation kit RMBK-12 is used to allow two Model 5304 units to be mounted in one space (1U) of a standard 19-inch equipment rack. The kit can also be used to mount one Model 5304 and one other Studio Technologies' product that is compatible with the RMBK-12, such as the Model 5421 Dante Intercom Audio Engine. The RMBK-12 installation kit contains two standard-length brackets, two joiner plates, eight 6-32 thread-pitch Phillips-head machine screws, and two 2-56 thread-pitch Torx™ T7 thread-forming machine screws. Refer to Appendix D for a visual explanation.

Get ready to install the kit by removing the four machine screws and associated "bump on" protectors from the bottom of each chassis. They are removed using a #1 Phillips screwdriver. Store the eight machine screws and eight "bump on" protectors for possible later use.

With assistance from a #2 Phillips screwdriver, use two of the 6-32 machine screws to attach one of the standard-length brackets onto the left side (when viewed from the front) of one of the Model 5304 units. The screws will mate with the threaded fasteners that can be seen on the side of the Model 5304's enclosure, near the front of the unit. Using two more of the 6-32 machine screws, attach one of the joiner plates onto the right side of that same Model 5304 unit.

Again using two of the 6-32 machine screws, attach the second standard-length bracket onto the right side of the second Model 5304 or another compatible unit. Using the final two 6-32 machine screws, attach the second joiner plate onto the left side of the second Model 5304 or other compatible unit with an orientation of 180 degrees from the way in which the first plate was installed.

To complete the assembly, "join" the units together by sliding each joiner plate through the other. The grooves in each joiner plate will carefully align with each other and form a relatively tight bond. Line up the two units so that the front panels form a common plane. With the aid of a Torx T7 screwdriver, use the two 2-56 Torx machine screws to secure the two joiner plates together. The screws should fit snugly into the small openings formed by the mating of the two joiner plates.

The 2-unit assembly is now ready to be mounted into the designated equipment rack. One space (1U or 1.75 vertical inches) in a standard 19-inch equipment rack is required. Secure the assembly into the equipment rack using two mounting screws per side.

Center Rack Mounting One Model 5304 Unit

Installation kit RMBK-13 allows one Model 5304 to be mounted in the center of one space (1U) of a standard 19-inch rack enclosure. The kit contains two medium-length brackets and four 6-32 thread-pitch Phillips-head machine screws. Refer to Appendix E for a visual explanation.

Get ready to install the kit by removing the four machine screws and associated "bump on" protectors from the bottom of the Model 5304's chassis. They are removed using a #1 Phillips screwdriver. Store the four machine screws and four "bump on" protectors for possible later use.

To prepare the unit to mount in the center of a rack enclosure, use a #2 Phillips screwdriver and two 6-32 machine screws to attach one of the medium-length brackets onto the left side (when viewed from the front) of the enclosure. The screws will mate with the threaded fasteners that can be seen on the side of the Model 5304's enclosure, near the front of the unit. Using two additional 6-32 machine screws, attach the other medium-length bracket onto the right side of the Model 5304's enclosure.

Once the two medium-length brackets have been installed the Model 5304 will be ready to be mounted into the designated equipment rack. One space (1U or 1.75 vertical inches) in a standard 19-inch equipment rack is required. Secure the unit into the equipment rack using two mounting screws per side.

Ethernet Connection with PoE

A 100BASE-TX Ethernet connection that supports Power-over-Ethernet (PoE) is required for Model 5304 operation. This one connection will provide both the Ethernet data interface and power for the Model 5304's circuitry. A 10BASE-T connection is not sufficient and a 1000BASE-T (GigE) connection is not supported unless it can automatically "fall back" to 100BASE-TX operation. The Model 5304 supports Ethernet switch power management, enumerating itself as a PoE class 2 device. Any source that is compliant with the IEEE® 802.3af standard will function correctly. Should the selected Ethernet switch port support Energy-Efficient Ethernet (EEE) it must be disabled to help ensure reliable Dante operation.

The Ethernet connection is made by way of an RJ45 jack that is located on the Model 5304's back panel. This allows connection by way of a RJ45 plug that's part of a typical Ethernet "patch cable." A crossover cable will never be required as the Model 5304's Ethernet interface supports auto MDI/MDI-X. The maximum cable distance is 100-meters (325-feet) for twisted-pair Ethernet cabling.

Remote Control Inputs

Provision has been made to allow external switches or contact closures to mimic the operation of one or two of the four intercom talk pushbutton switches or the aux pushbutton switch. The exact functioning of the two remote control inputs is determined by configuration settings, details of which are discussed later in this guide.

A 3-conductor 3.5 mm jack is located on the Model 5304's back panel and provides access to the two remote control inputs. The input circuitry is "active low," which means that they are enabled whenever they are connected (shorted) to the common connection. Technically, each remote-control input is created with a 3.4 k (3400) ohm resistor connected to +3.3 volts DC that acts as an input "pull up." Additional resistors and capacitors provide ESD protection, minimizing the chance of damage to a remote-control input due to static discharge or other extraneous signals. A current flow of approximately one milliampere is required for a remote-control input to be recognized as active.

Prepare an interconnecting cable and associated 3-conductor 3.5 mm plug to reflect that the tip lead is used by Remote Control Input 1, the ring lead by Remote Control Input 2, and the sleeve lead is the remote control common. Refer to Figure 2 for connection details.

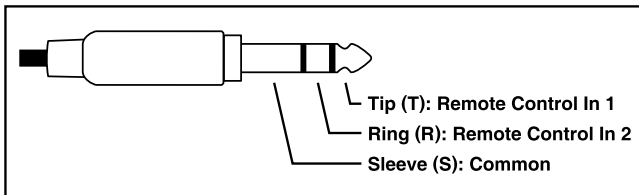

Figure 2. 3-conductor 3.5 mm (TRS) remote control in pinout diagram

Headset Connection

The Model 5304 provides a 5-pin female XLR connector that interfaces with an intercom or broadcast-style headset. The headset will incorporate both a microphone and headphones. The latter will provide either a dual-ear or single-ear headphone with dual-channel (stereo) or single-channel (monaural) audio performance. The headset connector is located on the front panel for easy access by the user. Refer to Figure 3 for headset connection details. The microphone input connections are compatible with most unbalanced or electret (low-voltage DC-powered) microphones. A balanced dynamic microphone should, in most cases, also function correctly if the signal – (low) is connected to Model 5304's mic in –/shield connection. No support is provided for microphones that require P12 or P48 phantom power.

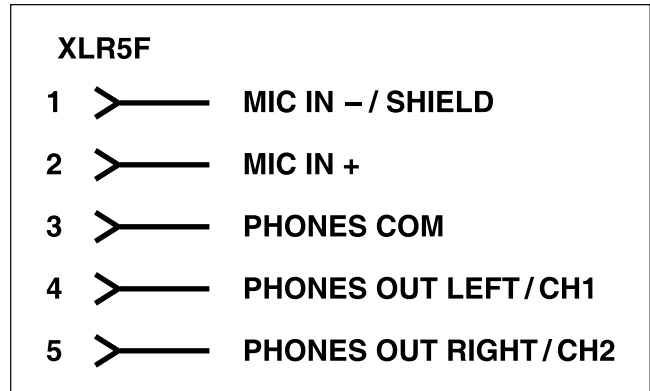

Figure 3. Headset connection pinout chart

To allow users of stereo (dual-earpiece or "double muff") headsets to hear a monaural version of the two headphone output channels does not require special wiring of the 5-pin male XLR mating connector. The headset's left headphone channel should always be wired to pin 4 and the right headphone channel to pin 5. Configuration choices, discussed later in this guide, can then be used to create the desired monaural output. It's important not to connect together (short) pins 4 and 5 of the Model 5304's headset connector as damage to the unit's output circuitry could result.

Monaural (single-earpiece or "single muff") headsets should be wired such that its headphone is wired only to pin 4; pin 5 should remain unused. Configuration choices, discussed later in this guide, can be used to create a monaural output.

It's possible that some Beyerdynamic headset interconnecting cable assemblies terminate the earpiece's left and right connections opposite from what the Model 5304 and other broadcast equipment requires. These cable assemblies may terminate the left earpiece to pin 5 of the XLR connector and the right earpiece to pin 4. If this condition is present, it will require reversing or "flipping" the two wires in a headset's 5-pin male XLR connector such that the left earpiece connects to pin 4 and the right earpiece to pin 5.

Dante Configuration

For audio to pass to and from the Model 5304 requires that several Dante-related parameters be configured. These configuration settings will be stored in non-volatile memory within the Model 5304's circuitry. Configuration will typically be done with the Dante Controller software application which is available for

download free of charge at audinate.com. Versions of Dante Controller are available to support the Windows and macOS personal computer operating systems. The Model 5304 uses the UltimoX4 4-input/4-output integrated circuit to implement its Dante interface. The unit is compatible with the Dante Domain Manager (DDM) software application.

Audio Routing

The four Dante receiver (input) channels associated with the Model 5304 need to be routed (connected) to Dante transmitter (output) channels on associated equipment. Configuration settings allow these four audio sources to ultimately be sent to the Model 5304's 2-channel headphone output. The Model 5304's four Dante transmitter (output) channels must be assigned to Dante receiver (input) channels on associated equipment. This achieves routing the Model 5304's four talk output audio channels to the device (or devices) that will be "listening" to them.

Within Dante Controller a "subscription" is the term used for routing a transmitter channel or flow (a group of up to four output channels) to a receiver channel or flow (a group of up to four input channels). The number of transmitter flows associated with an UltimoX4 integrated circuit is limited to two. These can either be unicast, multicast, or a combination of the two. If the Model 5304's transmitter (output) channels need to be routed using more than two flows it's possible that an intermediary device, such as the Studio Technologies' Model 5422A Dante Intercom Audio Engine, can be used to "repeat" the signals.

Unit and Channel Names

The Model 5304 has a default Dante device name of **ST-M5304-** followed by a unique suffix. The suffix identifies the specific Model 5304 that is being configured. The suffix's actual alpha and/or numeric characters relate to the MAC address of the unit's UltimoX4 integrated circuit. The four Dante transmitter (output) channels have default names of **Ch1**, **Ch2**, **Ch3**, and **Ch4**. The four Dante receiver (input) channels have default names of **Ch1**, **Ch2**, **Ch3**, and **Ch4**. Using Dante Controller, the default device name and channel names can be revised as appropriate for the specific application.

Device Configuration

The Model 5304 only supports an audio sample rate of 48 kHz with no pull-up/pull-down values available. The audio encoding is fixed for PCM 24. Device Latency and Clocking can be adjusted if required but the default value is typically correct.

Network Configuration – IP Address

By default, the Model 5304's Dante IP address and related network parameters will be determined automatically using DHCP or, if not available, the link-local network protocol. If desired Dante Controller allows the IP address and related network parameters to be manually set to a fixed (static) configuration. While this is a more-involved process than simply letting DHCP or link-local "do their thing," if fixed addressing is necessary then this capability is available. But in this case, it's highly recommended that a unit be physically marked, e.g., directly using a permanent marker or "console tape," with its specific static IP address. If knowledge of a Model 5304's IP address has been misplaced there is no reset button or other method to easily restore the unit to a default IP setting.

AES67 Configuration – AES67 Mode

The Model 5304 can be configured for AES67 operation. This requires the AES67 Mode to be set for Enabled. By default, AES67 mode is set for Disabled. Note that in the AES67 mode the Dante transmitter (output) channels will function in multicast; unicast is not supported.

Model 5304 Clocking Source

While technically the Model 5304 can serve as a Leader clock for a Dante network (as can all Dante-enabled devices) in virtually all cases the unit will be configured to receive "sync" from another device. As such, the check box for Preferred Leader associated with the Model 5304 would not be enabled.

Model 5304 Configuration

The STcontroller software application is used to configure the way in which the Model 5304 functions. No DIP switch settings or other local actions are used to configure the unit. This makes it imperative that STcontroller be available for convenient use on a personal computer that's connected to the related LAN.

Installing STcontroller

STcontroller is available free of charge on the Studio Technologies' website (studio-tech.com). Versions are available that are compatible with personal computers running selected versions of the Windows and macOS operating systems. If required, download and install STcontroller onto a designated personal computer. This personal computer must be on the same local area network (LAN) and subnet as the Model 5304 units that are to be configured. Immediately after starting STcontroller the application will locate all the Studio Technologies' devices that it can control. The one or more Model 5304 units to be configured will appear in the device list. Use the Identify command to allow easy recognition of a specific Model 5304 unit. Double-clicking on a device name will cause the associated configuration menu to appear. Review the current configuration and make any changes that are desired.

Changes made using STcontroller will be immediately reflected in the unit's operation; no Model 5304 reboot is required. Each time a change is made the multifunction display on the Model 5304's front panel will flash orange in a distinctive pattern to indicate that a command from STcontroller has been received.

General Menu Page

The following configuration selections are available in the General menu selections tab:

Microphone Input – Electret Power

Choices are *Enabled* or *Not Enabled* (box checked or not).

Enable the Electret Power check box if the connected headset has an electret microphone that requires a source of low-voltage DC power for operation. If the associated headset has a dynamic (non-powered) microphone do not enable the Electret Power check box. Most broadcast headsets that terminate on a 5-pin male XLR connector will not require microphone power. The electret power on/off status is displayed by way of a red LED, labeled MIC PWR, that is located on the left side of the Model 5304's front panel, adjacent to the headset connector.

Note that the Model 5304 cannot supply P12 or P48 phantom power that may be required for balanced condenser (capacitor) microphones. This should not

pose an issue as this type of microphone is essentially never associated with a headset that would be used for intercom applications.

Microphone Input – Gain

Choices are *24 dB*, *30 dB*, *36 dB*, *42 dB*, and *48 dB*.

The gain of the microphone preamplifier associated with the headset's microphone can be configured to operate from among five choices. The multifunction display, located on the Model 5304's front panel, can act as a guide when setting the preamplifier gain. When a voice signal at a normal level is present on the connected microphone and at least one of the talk buttons is active, the five green LEDs should light, the two orange LEDs may light intermittently. If, for example, all five green LEDs rarely or never light and the gain was set to 24 dB, it might be a good idea to change the setting to 30 dB or 36 dB. If either or both orange LEDs ever light then the selected gain should be reduced. A dynamics controller (compressor) circuit is associated with the output of the microphone preamplifier. This will impact the level as shown on the multifunction display. Selecting too much gain will result in the compressor circuit being active all the time, an undesirable sonic condition.

There's no problem changing the gain setting while the unit is operating although small audio clicks or pops may occur during gain transitions. Selecting the correct amount of gain might require some experimentation. The goal is to bring the microphone's signal up to the Dante reference level which Studio Technologies considers to be -20 dBFS. (This is 20 dB below digital maximum.) Operating in the range of this "reference" signal level will help ensure the delivery of "clean" audio to the destination devices. There's no "perfect" preamplifier gain setting that this guide can recommend. The two issues that impact the setting are the output sensitivity of the connected microphone and the acoustical output level of the microphone's user. With dynamic headsets selecting an initial setting of 42 dB would be appropriate. Users who speak loudly might need to have their gain reduced to 36 or even 30 dB. "Quiet" users might need a gain setting of 48 dB.

Aux Button – Mode

Choices are *All Talk*, *Call*, and *Disabled*.

The Aux button, located on the right side of the Model 5304's front panel, can be configured to perform either of two tasks. In addition, it can be disabled such that it performs no action. When selected for All Talk, pressing the Aux button will cause the four intercom talk buttons and associated intercom functions to become active. (The exception being if a button has been set for disabled.) This can be useful for applications where a user needs to easily connect their microphone to all the intercom channels. When selected for Call, pressing the Aux button will cause a call signal (20 kHz sinewave tone) to be sent out on all active intercom talk channels. If the Aux button is disabled then pressing it will cause no action to take place.

Sidetone – Level

Choices are *High*, *Medium High*, *Medium*, *Medium Low*, *Low*, and *Off*.

The Model 5304 includes a sidetone function that allows microphone audio coming from the microphone preamplifier and follow-on compressor circuit to be sent to the both channels of the headphone output. This serves as a user confirmation that they are actively sending audio out one or more of the intercom output channels. (Sidetone audio will only be routed to the headphone output when at least one of the talk channels is active.)

The level of the sidetone audio can be selected from among five values. The correct value is simply the one that makes the user most comfortable. Sidetone audio can also be disabled by selecting Off. Selecting Off would be useful only in special applications such as during troubleshooting or where user talk audio is being returned as part of their listen audio signals. The four rotary level controls associated with the intercom channels will not impact the sidetone level. The overall level control will impact the sidetone level.

Sidetone – Local Level Adjustment

Choices are *Off* and *On*.

A press-and-turn function can allow a Model 5304 user to adjust the sidetone level using the overall level control. When selected for On the user can select the sidetone level from among five values as well as off.

When selected for Off the user cannot change the sidetone level. It will strictly follow the sidetone level that has been selected using the configuration choice that was detailed previously.

Remote Control – Input 1

Choices are *Off*, *Channel 1*, *Channel 2*, *Channel 3*, *Channel 4*, and *Aux*.

The action performed when Remote Control In 1 is enabled will follow the configuration selected from among six choices. When Off is selected no action will be associated with the status of Remote Control Input 1. When Channel 1 is selected activating remote Control Input 1 will provide the same function as would happen when pressing the talk 1 pushbutton. (The exact action will depend on the button's configuration.) The same action will take place when selecting the configuration to be channels 2, 3, or 4. But in these cases, Remote Control Input 1 will control the action associated talk channels 2, 3, or 4 respectively. When Aux is selected activating Remote Control Input 1 will provide the same action as would occur if the Aux button was pressed.

Remote Control – Input 2

Choices are *Off*, *Channel 1*, *Channel 2*, *Channel 3*, *Channel 4*, and *Aux*.

The configuration choices and related actions for Remote Control In 2 are the same as those provided for Remote Control In 1.

System – LED Intensity

Choices are *High* and *Low*.

The five pushbutton switches and five rotary controls have LED indicators associated with them. The LED intensity configuration choice allows the overall intensity of these LEDs, as a group, to be selected. Deciding which choice, High or Low, is optimal will typically depend on the amount of ambient light that is present in the area where the Model 5304 is located.

System – Input Signal Present Display

Choices are *Off* and *On*.

The top surface of the knobs associated with the five rotary controls can light as an indication of the level of the audio associated with a specific control and related function. This is accomplished by the incorporation of RGB (red-green-blue) LEDs located within

each rotary control. If configured for On, the knob will light green when signal levels are in the normal range, yellow when the signal level is greater than normal, and red when the signal level is at risk of degrading audio performance. Note that even if the input signal present display function is set for Off the rotary controls will still display their normal and muted state using LED illumination.

System – Microphone Level Display

Choices are *Off* and *On*.

This configuration choice selects whether or not the level of the microphone preamplifier and follow-on compressor (dynamics control) circuit will display on the multifunction display. When selected for Off the eight LEDs in the multifunction display will not respond to the microphone level. If selected for On the multifunction display will respond to the output level of the microphone preamplifier and compressor whenever one or more of the talk functions is enabled. Selecting On would be appropriate when adjusting the gain of the microphone preamplifier.

System – Channel Button Action

Choices are *One Only* and *Multiple*.

This mode allows the relationship between the four talk buttons to be configured. In the One Only mode, only one of the four talk buttons can be active at any one time. A talk button that has been “latched on” will automatically unlatch if another talk button becomes active. This is sometimes known as a “radio button” mode in homage to how radio station selection buttons in an automobile radio can be configured. If Multiple is selected then one or more of the talk buttons can be simultaneously enabled. Pressing one button will not impact the status of the others.

System – Button LED Action

Choices are *Red when Off/Green when On*, *Green when Off/Red when On*, *Unlit when Off/Green when On*, and *Unlit when Off/Red when On*.

The action of the red and green LED indicators associated with the four talk pushbutton switches can be configured. (There are two red and two green LEDs in each of the pushbutton switches.) The LEDs action in the talk pushbutton switches are configured as a group, all acting in the same manner. The third and fourth choices were specifically provided to support

users who have limitations in their ability to discern between two colors (“color blindness”). Note the LEDs in the Aux pushbutton switch will not be impacted by this configuration setting. Its LEDs will always perform the same action.

Red when Off/Green when On: The LEDs in each of the four talk pushbutton switches will light red when its associated function is off (not active). The LEDs in each pushbutton switch will light green when its associated function is on (active).

Green when Off/Red when On: The LEDs in each of the four talk pushbutton switches will light green when its associated function is off (not active). The LEDs in each pushbutton switch will light red when its associated function is on (active).

Unlit when Off/Green when On: The LEDs in each of the four talk pushbutton switches will not light when its associated function is off (not active). The LEDs in each pushbutton switch will light green when its associated function is on (active).

Unlit when Off/Red when On: The LEDs in each of four talk pushbutton switches will not light when its associated function is off (not active). The LEDs in each pushbutton switch will light red when its associated function is on (active).

System – Headset Channel Solo

Choices are *Off*, *6 dB*, *9 dB*, *12 dB*, *15 dB*, and *Full Mute*.

This configuration choice allows an audio console “solo” function to be available to Model 5304 users. When selected for Off the solo function is disabled. When one of the five other solo modes has been selected then pressing one of the four rotary controls associated with the four intercom channels will cause the solo mode to be enabled. The level of the audio signal associated with the “soloed” channel will remain the same. But the audio level of any signal associated with the other intercom channels will be reduced in level by either 6, 9, 12, or 15 dB or fully muted.

System – Microphone Kill

Choices are *Off*, *Device ID*, *Global Kill Command*, and *Device ID/Global Kill Command*.

The mic kill function allows a network-provided message to automatically disable any of the four talk

channels that are “latched” on. Specifically, it’s possible to remotely change all active (on) talk channels to their off state. This function is sometimes referred to as a “talk off” function. There are two means available to remotely disable all active talk channels. The Device ID method uses the identification command generated by the Dante Controller or STcontroller applications as a “trigger” to disable any active talk channels. The Global Kill Command can be generated by applications that incorporate the Studio Technologies’ proprietary message generation method. This method utilizes the sending of a data command over the Ethernet connection. Select the desired microphone kill configuration from among the four choices. Either method can be selected to function individually, or both can be selected to be recognized. Selecting Off simply means that no remote microphone control (“mic kill”) is supported.

Channel Specific Menu Page

The following configurations apply individually to intercom talk Channels 1 through 4. Each is available for the four channels although only channel 1 will be described.

Button Mode

Choices are *Push to Talk*, *Tap to Latch*, *Push to Talk/Tap to Latch*, and *Disabled*.

The manner in which the talk button functions can be configured from among four choices.

Push to Talk: If this mode is selected the button’s function will normally be inactive. Whenever the button is pressed its associated function will become active.

Tap to Latch: If this mode is selected the button’s function will alternate between its active and inactive states whenever the button is pressed. Upon Model 5304 power up the button will be in its inactive state.

Push to Talk/Tap to Latch: This mode is a combination of the Push to Talk and Tap to Latch modes. It’s similar to the way in which pushbutton switches often function on user stations associated with broadcast or production intercom systems. If the button is pressed and held the associated function will become active. It will stay active until the button is released. If the button is “tapped” the status of the function will change, either from inactive-to-active or from active-to-inactive. Upon Model 5304 power up the button will be in its inactive state.

Disabled: In this mode, the button will not perform a function. Pressing it will simply cause the button to flash red, indicating that it has been disabled.

Button Function

Choices are *Talk* and *Talk with 18 kHz*.

The audio action that occurs when the talk channel function becomes active will follow this configuration. There are two modes available.

Talk: In this mode, whenever the specific talk channel is active microphone audio will be sent out the associated Dante transmitter (output) channel. The sidetone function will be active whenever the talk function is active.

Talk with 18 kHz Tone: This mode is similar to the Talk mode except that an 18 kHz sine wave tone is added (mixed or summed) with the microphone audio. It is intended for use in REMI/At-Home intercom applications where a “pilot tone” needs to be sent along with talk audio. This capability was specifically provided for use with the tone-activated (“TOX”) IFB function in the Studio Technologies’ Model 5422A Dante Intercom Audio Engine product or the IFB (talent cue) function in the Models 232, 234, and 236 Announcer’s Consoles. The sidetone function will be active whenever the Talk with 18 kHz Tone function is active.

Headphone Routing

Choices are *Left*, *Right*, and *Left and Right*.

The audio associated with the Model 5304’s Dante receiver (input) channel can be monitored using the headset’s headphone outputs. The destination channel(s) can be configured as desired.

Left: In this mode, the input audio will be sent only to the left headphone output channel.

Right: In this mode, the input audio will be sent only to the right headphone output channel.

Left and Right: In this mode, the input audio will be sent to both the left and right headphone output channels.

Call Indication

Choices are *Off*, *Flash*, *Solid*, and *Flash then Solid*.

The Call Indication configuration allows the manner in which the four talk pushbutton switches will light when a call signal is detected on its respective Dante

receiver (input) channel. Technically, call is detected as being active when a 20 kHz nominal audio tone is present in an audio signal path. (It would typically be a sine- or square wave signal that's combined with voice audio.)

Off: When this mode is selected and a call signal is detected in a Dante receiver (input) channel then the associated pushbutton will not light.

Flash: In this mode, the pushbutton will flash orange if a call signal is detected and the channel's talk function is not active. If the channel's talk function is active when a call signal is detected then the button will flash alternately green and orange. (Green indicates that the talk function is active and orange indicates that a call signal is detected.)

Solid: When this mode is selected then a button will light orange when a call signal is detected; it will light orange whether or not the talk function associated with that button is active.

Flash then Solid: In this mode, a button will first flash orange (or green and orange) for a few seconds and then light solid orange, remaining lit orange until the call signal is no longer present.

Operation

At this point, all connections and configuration steps should have been completed and everything should be ready for Model 5304 operation to commence. The unit should have been placed at the desired physical location. One of the optional mounting kits may have been used if mounting in a panel opening, a flat surface, or in a 19-inch rack enclosure was required. An Ethernet connection with Power-over-Ethernet (PoE) capability should have been made to the unit's RJ45 jack. A single- or dual-ear headset should have been connected.

The Model 5304's Dante configuration settings should have been made using the Dante Controller software application. In this way, the unit's four Dante transmitter (output) channels and four Dante receiver (input) channels should have been routed, by way of Dante "subscriptions," to the receiver and transmitter channels on associated Dante-enabled equipment. Using the Studio Technologies' STcontroller software application the unit's configuration should have been selected to meet the needs of the specific application.

Initial Operation

The Model 5304 will begin to function as soon as a Power-over-Ethernet (PoE) source is connected. However, it will typically take 20 to 30 seconds for full operation to commence. Upon initial power up, the green LED associated with the firmware update connector on the back panel will light for a few seconds indicating that the internal processor has begun to operate. Then the unit's two Ethernet status LEDs, labeled LINK and ACT and also located on the back panel below the RJ45 jack, will begin to light as the network connection is established.

After the unit's application firmware (embedded software) has started a brief LED test sequence will take place on the front panel. The microphone power LED will briefly light red. The eight LEDs associated with the multifunction display will sequentially light red and then light green. The five pushbutton switches will first light red and then light green. The knobs associated with the five rotary controls will light red, then green, then blue.

Normal operation of the front-panel buttons and rotary controls will now commence. Preparation of the Dante interface for operation will take a few more seconds and the multifunction display will indicate its status. The multifunction display's eight LEDs will, as a group, slowly flash green as the Dante interface is initializing. It's typical for four, five, or six flashes to occur over a period of 8 to 15 seconds. The multifunction display will stop lighting in this startup sequence when the Dante interface is functioning correctly.

Once that entire start-up sequence has completed and the Dante connection has been established full operation of the Model 5304 can begin. At this time, all the various buttons, rotary encoders, and LEDs will become operational.

How to Identify a Specific Model 5304

User-activated functions within the Dante Controller and STcontroller software applications allow a specific Model 5304 unit to be identified. Each application provides an "eyeball" icon that when clicked will activate the Identify function. When this function is selected a command will be sent to a specific Model 5304 unit. On that unit's multifunction display the eight LEDs will flash red in a distinctive pattern three times. While

the identify sequence is taking place all other normal Model 5304 operation will continue to take place.

Ethernet Status LEDs

As previously discussed, the two Ethernet status LEDs, LINK and ACT, are located below the RJ45 jack on the unit's back panel. The LINK LED will light yellow whenever an active connection to a 100 Mb/s Ethernet network has been established. The ACT LED will flash green in response to all Ethernet data packet activity.

Microphone Power LED

A red LED is located on the unit's front panel, below and to the left of the headset connector. It is labeled MIC PWR and displays the status of the low-voltage DC power source that can be provided for the headset's microphone. If the connected headset utilizes an electret microphone, the microphone power source should be enabled. If the headset's microphone is the more-common dynamic (non-powered) type it won't require microphone power.

Talk Pushbutton Switches

Four pushbutton switches are used to select how the audio signal associated with the headset's microphone will be routed to the four Dante transmitter (output) channels. How the talk pushbutton's function and what LED color and action is associated with them will depend on the configuration choices that have been made using STcontroller. When the function associated with the four buttons is inactive (off) the pushbutton switch's LED can be lit red or green, or not be lit at all. When the function is active (on) the pushbutton switch's LED may be lit orange, red, or green.

Pushbutton Switch Modes

There are four ways that the pushbutton switches will respond to being pressed. The specific way in which each will operate will depend on its selected mode configuration.

Push to Talk: If this mode is selected the function will become active whenever the pushbutton is pressed and held.

Tap to Latch: If this mode is selected the function will alternate between its active and inactive states whenever the pushbutton switch is pressed ("tapped"). Upon Model 5304 power up the function will be in its inactive state.

Push to Talk/Tap to Latch: This mode is a combination of the Momentary and Tap to Latch modes. It's similar to the way in which talk pushbuttons function on user stations associated with common broadcast or production intercom systems. If the pushbutton switch is pressed and held the function will become active and will remain so until the pushbutton is released. If the pushbutton is momentarily pressed ("tapped") the function will change state. Upon Model 5304 power up the function will be in its inactive state.

Disabled: This mode is selected only if the function is not going to be utilized. In this mode, pressing the pushbutton switch will simply result in the switch momentarily flashing red.

Talk Button Functions

The function associated with each of the four talk pushbutton switches and its associated Dante transmitter (output) channel can be configured from among two choices. The STcontroller software application is used to individually select the mode for each of the four talk channels.

Talk: When this mode is selected the pushbutton switch will cause audio associated with the headset's microphone to be sent to the associated Dante transmitter (output) channel.

Talk with 18 kHz Tone: When this mode is selected the pushbutton switch will cause audio associated with the headset's microphone, along with an 18 kHz sine wave tone, to be sent to the associated Dante transmitter (output) channel.

Talk Button Enable – Multiple or One Only

A setting in STcontroller determines if multiple talk buttons can be active at the same time or if only one talk button can be latched on (enabled) at any one time. In most applications, the Model 5304 will be configured such that two or more of the four talk buttons can be enabled at the same time. In this way, the action of the four talk buttons does not impact each other. For special applications, the unit can be configured such that only one talkback function can be latched on at any one time. If this configuration setting has been selected then pressing any of the four talk buttons will cause any other talk button that is currently latched on to turn off.

Aux Pushbutton Switch

A fifth pushbutton switch, labeled AUX, can serve as either an all talk or a call function. It can also be disabled. The function associated with it depends on how it has been configured in STcontroller. When the aux function is not active its button will not be lit. When the aux function is active its pushbutton switch will be lit orange. The aux pushbutton switch always provides a push-to-activate function; it cannot be configured to “latch” on or off.

If configured for All Talk, pressing the aux button will cause all four of the talk buttons and associated functions to become active. (The only exception is if a talk channel has been disabled.) If configured for Call, pressing the aux button will cause a 20 kHz sine wave “call” tone to be added to any currently active talk channel. When Call is active the active talk buttons will flash orange.

Headset Audio Operation

Audio associated with each of the four Dante receiver (input) channels can be configured to be sent to the left, right, or both the left and right headphone output channels. The level of each input is controlled using the rotary control that is located above the four talk pushbutton switches. The top of the knob will light dark blue when audio associated with the Dante receiver (input) channel is being routed to the headphone output. Each input can be muted by momentarily pressing (“tapping”) the knob associated with each rotary control. When a receiver channel has been muted the top of its associated knob will light purple.

The Model 5304 can be configured such that the top of the knob associated with the rotary control can light in a rough approximation of the level of the signal that’s present on the Dante receiver (input) channel. If the STcontroller application has been configured such that the knob won’t display the input audio signal level its operation is simple to understand. The top of the knob will never light green, yellow, or red.

If STcontroller has been used to enable the input signal level display, the top of the knob will light green to indicate that a signal at a normal level is present. The top of the knob will light yellow to indicate that the input signal is at an abnormally high level. While not detrimental, this level is something that should be reduced if possible. If the top of the knob lights red

then the input signal is close to, or has reached, its maximum. A signal at this level is problematic, having a good chance of being distorted or at imminent risk of becoming so. The source level of the Dante receiver (input) signal should be reduced.

The overall level of the left and right headphone output channels can be controlled using the rotary control that’s located on the left side of the Model 5304’s front panel. Both headphone output channels can be muted by momentarily pressing (“tapping”) the knob associated with the rotary control. The knob will light purple when the headphone output is muted.

Multifunction Display

The multifunction display, located on the left side of the Model 5304’s front panel and under the overall headphone level rotary control, provides eight bi-color LEDs that will indicate a number of Model 5304 conditions. The LEDs can individually light red, green, or orange (a combination of both red and green). Upon unit power up the multifunction display will slowly flash green as an indication that the Dante interface connection is being established. When the Identify command is received (after being generated by the Dante Controller or STcontroller software application) the multifunction display will flash orange in a unique pattern. When any of the five rotary controls is turned in either direction the multifunction display will indicate the approximate level of the associated function.

If enabled in the STcontroller application, the level of headset’s microphone signal as it is being sent to one or more of the Dante transmitter (output) channels can be displayed. When this condition is active the multifunction display will provide a level meter function. The five LEDs on the left will light green to indicate a microphone signal that is at a normal level. The sixth and seventh LEDs, when counted from the left, will light orange when a signal is above normal. The LED on the far right will light red when the microphone signal is near to, or has reached, the maximum level. This function can be useful to ensure that the unit’s microphone preamplifier has been configured optimally for the connected headset.

Sidetone Operation

The sidetone function allows audio from the headset’s microphone to be sent to the headphone output channels. The sidetone function is active whenever one or

more of the four talk channels is active. The sidetone level can be one of the five configurable choices or fully muted. Depending on the unit's configuration as made in STcontroller, a user may be allowed to adjust the sidetone level. Pressing and holding the knob associated with the headphone overall level control will cause LEDs on the multifunction display to light to indicate the sidetone level. The current level will be represented by the number of LEDs that are lit red. If, for example, the left five LEDs are lit red it would indicate that the maximum sidetone level has been selected. If no LEDs are lit it will indicate that the sidetone output is fully muted.

If configured in STcontroller to allow the user to adjust the sidetone level, while continuing to press the overall headphone level knob, rotating the same knob will allow the sidetone level to be adjusted over the five steps and fully mute. Turning the knob clockwise will increase the sidetone level (unless it is already at maximum). Turning the knob counterclockwise will decrease the sidetone level (again, unless it is already fully muted). The five red LEDs on the left will indicate the five sidetone level choices. No LEDs lit will indicate that the sidetone output has been selected to be fully muted.

Solo Operation

The Model 5304 offers a "solo" function similar to that found on audio consoles. This is provided to assist a user in monitoring a single audio signal while in "real time." If the solo function has been enabled in STcontroller, pressing a knob associated with a Dante receiver (input) channel's rotary control will enable the solo function for that input. The level and headphone output channel assignment will be maintained. (This maintains the left-only, right-only, or both left and right channel routing; sometimes called "solo in place.") When the solo function is active the knobs associated with the non-soloed Dante receiver (input) channels will be lit light blue. When a non-soloed channel has entered the solo mode its level may be reduced by an amount configured in STcontroller. Choices include 6 dB, 9 dB, 12 dB, 15 dB, and full mute. If the solo function has been enabled more than one channel can be soloed at any one time. However, in most cases, only one channel will be soloed at any one time.

Call Indication

Each of the four Dante receiver (input) channels can be configured to recognize a call signal that is present in the associated audio path. These "in-band" call signals are high-frequency sine or square wave signals, typically 20 kHz, that are generated by a variety of party-line (PL) intercom devices. STcontroller settings allow the call action for each channel to be individually selected. If Flash is selected then the top of the knob associated with that channel will flash orange when a call signal is being received. If Solid is selected the top of the knob associated with that channel will light orange when a call signal is received. If the Flash then Solid configuration choice is selected then the top of the knob associated with that channel will flash orange for a few seconds and then light orange.

Microphone Kill

There can be situations where one or more of the Model 5304's talk channels have been left enabled and a means of changing that condition using a remote method is desired. (In the intercom world, this has typically been referred to a "microphone kill" or "mic kill" function.) This channel-enabled condition could occur if a talk channel was configured for Tap to Latch or Push to Talk/Tap to Latch and a user had latched-on a channel. A setting in STcontroller allows a remotely generated command to unlatch (mic kill) the one or more channels that may be impacting the overall intercom system by having microphone audio present when it should not be. Within STcontroller there is the option of selecting from among three command choices as well as having the microphone kill function disabled. The Dante-standard Identify command can be selected. This will cause the LEDs in the multifunction display to light as well as causing any applicable channels to unlatch. A special command, presented to the unit via the Ethernet connection, can also be utilized. This command is designed to be sent to all devices in a Dante network and will simultaneously unlatch any active channel. In most cases, a custom computer program would have to be created to generate this command. The third STcontroller choice is to allow both the Identify command and the special command to cause all latched channels to unlatch.

Remote Control

It's possible that an application will have connected one or two external contact closures to control the on and off state of two of the Model 5304's four talk channels. These external contacts would be in addition to the normal pushbutton switches on the unit's front panel. A connector, located on the Model 5304's back panel, provides access to two remote-control hardware inputs. Configuration settings in STcontroller will determine the action that connections to the hardware inputs will have. This capability is mentioned in this paragraph only so that a user would not be confused should talk channels be enabled or disabled without use of the unit's pushbutton switches.

Technical Notes

Headphone High-Frequency Response

Alert users reviewing the Model 5304's specifications will find that the effective high-frequency response of the headphone output channels is limited to about 10 kHz. This is by design, with digital filtering providing a -3 dB point at 9.8 kHz. This is implemented specifically so that any high-frequency signals, such as call tones, present in a Dante receiver (input) channel would never "pass on" to the headphone output. This will prevent non-voice audio content from being sent to headphones and possibly causing user discomfort. This high-frequency roll-off filtering would be specifically important in situations such as when call tones are part of a connected Dante audio source. These call tones are typically 20 kHz sine or square wave signals. The Model 5304 can respond to these tones by the lighting of LEDs but wouldn't let them impact the headphone output channels.

IP Address Assignment

By default, the Model 5304's Dante-associated Ethernet interface will attempt to automatically obtain an IP address and associated settings using DHCP (Dynamic Host Configuration Protocol). If a DHCP server is not detected an IP address will automatically be assigned using the link-local protocol. This protocol is known in the Microsoft® world as Automatic Private IP Addressing (APIPA). It is also sometimes referred to as auto-IP (PIPPA). Link-local will randomly assign a unique IP address in the IPv4 range of 169.254.0.1 to 169.254.255.254. In this way, multiple Dante-enabled

devices can be connected together and automatically function, whether or not a DHCP server is active on the LAN. Even two Dante-enabled devices that are directly interconnected using an RJ45 patch cord will, in most cases, correctly acquire IP addresses and be able to communicate with each other.

An exception does arise when trying to directly interconnect two Dante-enabled devices that use Ultimo integrated circuits to implement Dante. The Model 5304 uses an UltimoX4 "chip" and, as such, a direct one-to-one interconnection between it and another Ultimo-based product would typically not be supported. An Ethernet switch linking these units would be required to successfully interconnect the two Ultimo-based devices. The technical reason that a switch is required relates to the need for a slight latency (delay) in the data flow; an Ethernet switch will provide this. This wouldn't typically prove to be an issue as the Model 5304 uses Power-over-Ethernet (PoE) to provide its operating power. As such, in most cases a PoE-enabled Ethernet switch would be utilized to support Model 5304 units.

Using the Dante Controller software application, the Model 5304's IP address and related network parameters can be set for a manual (fixed or static) configuration. While this is a more involved process than simply letting DHCP or link-local "do their thing," if fixed addressing is necessary then this capability is available. But in this case, it's highly recommended that every unit be physically marked, e.g., directly using a permanent marker or "console tape," with its specific static IP address. If knowledge of a Model 5304's IP address has been misplaced there is no reset button or other method to easily restore the unit to a default IP setting.

In the unfortunate event that a device's IP address is "lost," the Address Resolution Protocol (ARP) networking command can be used to "probe" devices on a network for this information. For example, in Windows OS the **arp -a** command can be used to display a list of LAN information that includes MAC addresses and corresponding IP addresses. The simplest means of identifying an unknown IP address is to create a "mini" LAN with a small PoE-enabled Ethernet switch connecting a personal computer to the Model 5304. Then by using the appropriate ARP command the required "clues" can be obtained.

Optimizing Network Performance

For best Dante audio-over-Ethernet performance a network that supports VoIP QoS capability is recommended. In applications that utilize multicast Ethernet traffic enabling IGMP snooping can be valuable. (In this case, ensure that support for PTP timing messages is still available.) These protocols can be implemented on virtually all contemporary managed Ethernet switches. There are even specialized switches that are optimized for entertainment-associated applications. Refer to the Audinate website (audinate.com) for details on optimizing networks for Dante applications.

Application Firmware Version Display

A selection in the STcontroller software application allows the Model 5304's application firmware version to be identified. This can be useful when working with factory personnel on application support and troubleshooting. To identify the firmware version, begin by connecting the Model 5304 unit to the network (via Ethernet with PoE) and wait until the unit starts to function. Then, after starting STcontroller, review the list of identified devices and select the specific Model 5304 for which you want to determine its application firmware version. Then select **Version and Information** under the **Device** tab. A page will then display that will provide lots of useful information. This includes the application firmware version and well as details on the Dante interface firmware.

Application Firmware Update Procedure

It's possible that updated versions of the application firmware (embedded software) that is utilized by the Model 5304's microcontroller (MCU) integrated circuit will be released to add features or correct issues. Refer to the Studio Technologies' website for the latest application firmware file. The unit has the ability to load a revised file into its MCU's non-volatile memory by way of a USB interface. The Model 5304 implements a USB host function that directly supports connection of a USB flash drive. The Model 5304's MCU updates its application firmware using a file named **M5304XvXX.stm** where Xs are decimal digits that represent the version number.

The update process begins by preparing a USB flash drive. The flash drive doesn't have to be empty (blank) but must be in the personal-computer-standard FAT32 format. The processor in the Model 5304 is compatible with USB 2.0, USB 3.0, and USB 3.1-compliant Flash drives. Save the new firmware file in the root folder with a name of **M5304vXrXX.stm** where XrXX is the actual version number. Studio Technologies will supply the application firmware file inside a .zip archive file. While the firmware file inside of the zip file will adhere to the naming convention required by the Model 5304, the name of the zip file itself will include the file's version number. For example, a file named **M5304v1r04MCU.zip** would indicate that version 1.04 of the application firmware (**M5304v1r04.stm**) is contained within this zip file along with a readme (.txt) text file.

Once the USB flash drive is inserted into the USB host interface, located on the back panel of the Model 5304, the unit must be powered off and again powered on. At this point, the file from the USB flash drive will automatically load. The precise steps required will be highlighted in the next paragraphs of this guide.

To install the application firmware file, follow these steps:

1. Disconnect power from the Model 5304. This will entail removing the Ethernet connection that is made to the RJ45 jack on the back panel.
2. Locate the USB receptacle on the back of the unit. Insert the prepared USB flash drive into it.
3. Apply power to the Model 5304 by connecting an Ethernet signal that has Power-over-Ethernet (PoE) present to the RJ45 jack.
4. After a few seconds the Model 5304 will run a "boot loader" program that will automatically load the new application firmware file (**M5304vXrXX.stm**). This loading process will take only a few seconds. During this time period the green LED that's located adjacent to the USB receptacle will flash slowly. Once the entire loading process is over, taking approximately 10 seconds, the Model 5304 will restart using the newly loaded application firmware.

5. At this time, the Model 5304 is functioning with the newly loaded application firmware and the USB flash drive can be removed. But to be conservative, remove the PoE Ethernet connection first and then remove the USB flash drive. Re-connect the Ethernet signal to restart the unit.
6. Using STcontroller, confirm that the desired application firmware version has been correctly loaded.

Note that upon power being applied to the Model 5304 if a connected USB flash drive doesn't have the correct file (**M5304vXrXX.stm**) in its root folder no harm will occur. Upon power up the adjacent green LED will flash on and off rapidly for a few seconds to indicate this condition and then normal operation using the unit's existing application firmware will begin.

Ultimo Firmware Update

As previously discussed in this guide, the Model 5304 implements its Dante connectivity using the UltimoX4 integrated circuit from Audinate. The Dante Controller software application can be used to determine the version of the firmware (embedded software) that resides in this integrated circuit. The firmware (embedded software) residing in the UltimoX4 can be updated using the Model 5304's Ethernet port. Performing the update process is easily accomplished using an automated method called Dante Updater that's included as part of the Dante Controller application. This application is available, free of charge, from the Audinate website (audinate.com). The latest Model 5304 firmware file, with a name in the form of **M5304vXrXrX.dnt**, is always available on the Studio Technologies' website as well as being part of Audinate's product library database. The latter allows the Dante Updater software application that is included with Dante Controller to automatically query and, if required, update the Model 5304's Dante interface.

Restoring Factory Defaults

A command in the STcontroller software application allows the Model 5304's defaults to be reset to the factory values. From STcontroller select the Model 5304 for which you want to restore its defaults. Select the **Device** tab and then the **Factory Defaults** selection. Then click on the OK box. Refer to Appendix A for a list of the Model 5304's factory defaults.

Specifications

Power Source:

Power-over-Ethernet (PoE): class 2 (low power, ≤6.49 watts) per IEEE® 802.3af

Network Audio Technology:

Type: Dante audio-over-Ethernet

AES67-2018 Support: yes, selectable on/off

Dante Domain Manager (DDM) Support: yes

Bit Depth: up to 24

Sample Rate: 48 kHz

Pull-Up/Down Support: no

Dante Transmitter (Output) Channels: 4

Dante Receiver (Input) Channels: 4

Dante Audio Flows: 4; 2 transmitter, 2 receiver

Transmitter (Output) and Receiver (Input)

Nominal Level: –20 dBFS

Audio Channels: 4 talk, 4 listen

Network Interface:

Type: 100BASE-TX, Fast Ethernet per IEEE 802.3u (10BASE-T and 1000BASE-T (GigE) not supported)

Power-over-Ethernet (PoE): Per IEEE 802.3af

Data Rate: 100 Mb/s (10 Mb/s and 1000 Mb/s not supported)

Microphone Input:

Compatibility: analog dynamic or electret microphones

Type: unbalanced

Electret Microphone Power: 3.3 volts DC via 2 k (2000) ohms series resistance, selectable on/off

Gain: 24, 30, 36, 42, or 48 dB, selectable

Frequency Response: 42 Hz to 18 kHz, –3 dB, nominal

Distortion (THD+N): <0.03%, 1 kHz, 24 dB gain

Noise Floor: –94 dBFS (A-weighted)

Compressor:

Threshold: 1.5 dB above nominal level (–18.5 dBFS)

Slope: 2:1

Headphone Output:

Type: 2-channel

Compatibility: intended for connection to stereo (dual-channel) or monaural (single-channel) headsets with nominal impedance of 50 ohms or greater

Maximum Output Voltage: 2.9 Vrms, 1 kHz, with 150 ohm load

Frequency Response: 7 Hz to 9.8 kHz, –3 dB

Distortion (THD+N): <0.02%

Dynamic Range: >100 dB

Call Send Function:

Signaling Method: 20 kHz, within selected Dante transmitter (output) audio channels

Send Level: –20 dBFS

Call Receive Function:

Sources: Dante receiver (input) channels 1-4

Signaling Method: 20 kHz +/-800 Hz, nominal, within audio channels

Receive Level: –27 dBFS minimum

Detect Time: 10 milliseconds, minimum

Remote Control Inputs: 2

Function: configurable, can mimic the action of any of the five button functions

Type: active low, 1 mA maximum, inputs pulled up to 3.3 volts DC via 3.4 k (3400) ohm resistors

Connectors:

Headset: 5-pin female XLR

Ethernet: RJ45 jack

Remote Control Inputs: 3-conductor (TRS) 3.5 mm jack

USB: type A receptacle (used only for updating application firmware)

Configuration: requires Studio Technologies' STcontroller software application

Software Updating: USB flash drive used for updating application firmware; Dante Updater application for updating Dante interface firmware

Environmental:

Operating Temperature: 0 to 50 degrees C
(32 to 122 degrees F)

Storage Temperature: -40 to 70 degrees C
(-40 to 158 degrees F)

Humidity: 0 to 95%, non-condensing

Altitude: not characterized

Dimensions (Overall):

8.7 inches wide (22.1 cm)

1.72 inches high (4.4 cm)

4.45 inches deep (11.3 cm)

Weight: 0.95 pounds (0.42 kg); rack-mounting installation kits add approximately 0.2 pounds (0.09 kg)

Deployment: intended for tabletop applications.

Four optional mounting kits are also available:

RMBK-10 allows one unit to be mounted in a panel cutout or on a flat surface

RMBK-11 allows one unit to be mounted in the left- or right-side of one space (1U) of a standard 19-inch rack

RMBK-12 allows two units to be mounted in one space (1U) of a standard 19-inch rack

RMBK-13 allows one unit to be mounted in the center of one space (1U) of a standard 19-inch rack

Specifications and information contained in this User Guide subject to change without notice.

Appendix A–STcontroller Default Configuration Values

General Menu Page:

Microphone Input – Electret Power: Off (select box not checked)

Microphone Input – Gain: 36 dB

Aux Button – Mode: Call

Sidetone – Level: Medium

Sidetone – Local Level Adjustment: On

Remote Control – Input 1: Off

Remote Control – Input 2: Off

System – LED Intensity: High

System – Input Signal Present Display: On

System – Microphone Level Display: On

System – Channel Button Action: Multiple

System – Button LED Action: Red when Off/Green when On

System – Headset Channel Solo: Full Mute

System – Microphone Kill: Global Kill Command

Channel Specific Menu Page (all parameters identical for Channels 1-4):

Button Mode: Push to Talk/Tap to Latch

Button Function: Talk

Headset Routing: Left and Right

Call Indication: Flash

Model 5304
INTERCOM STATION

Appendix B—Graphical Description of the Installation Kit for Panel Cutout or Surface-Mounting Use (Order Code: *RMBK-10*)

This installation kit is used for mounting one Model 5304 unit into a panel cutout or flat surface.

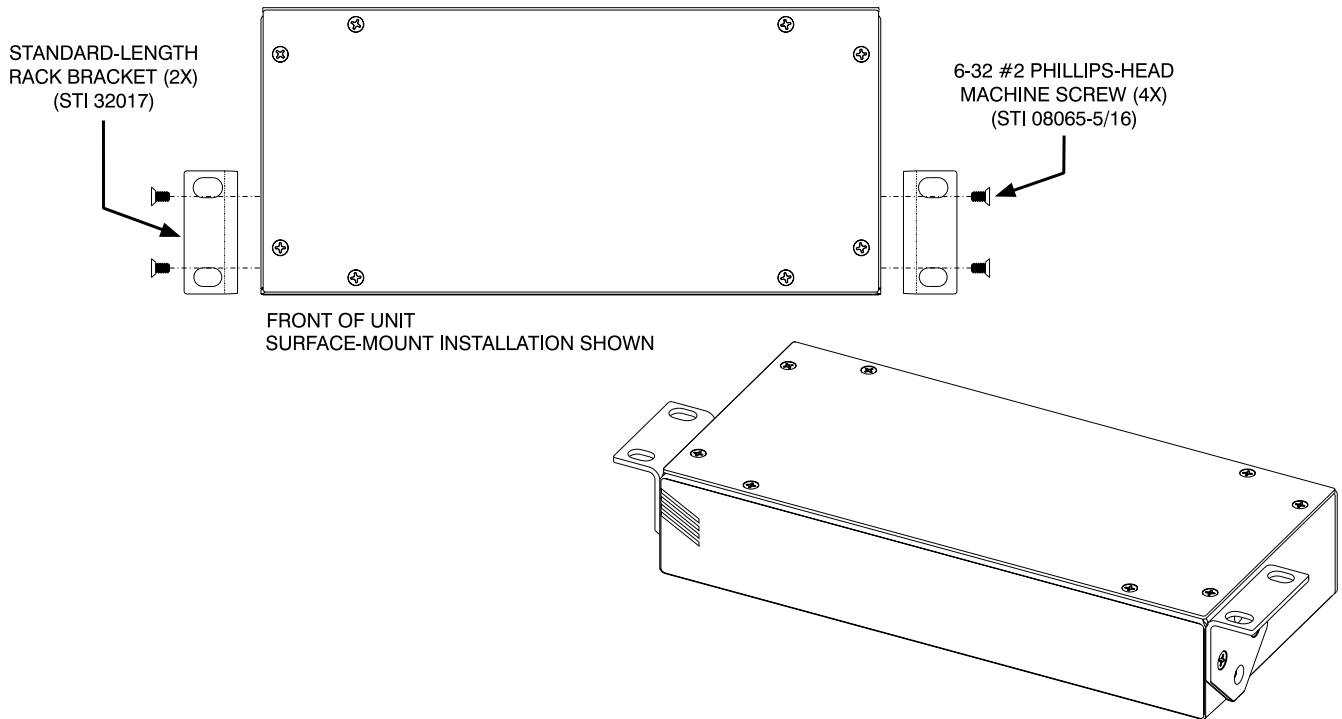
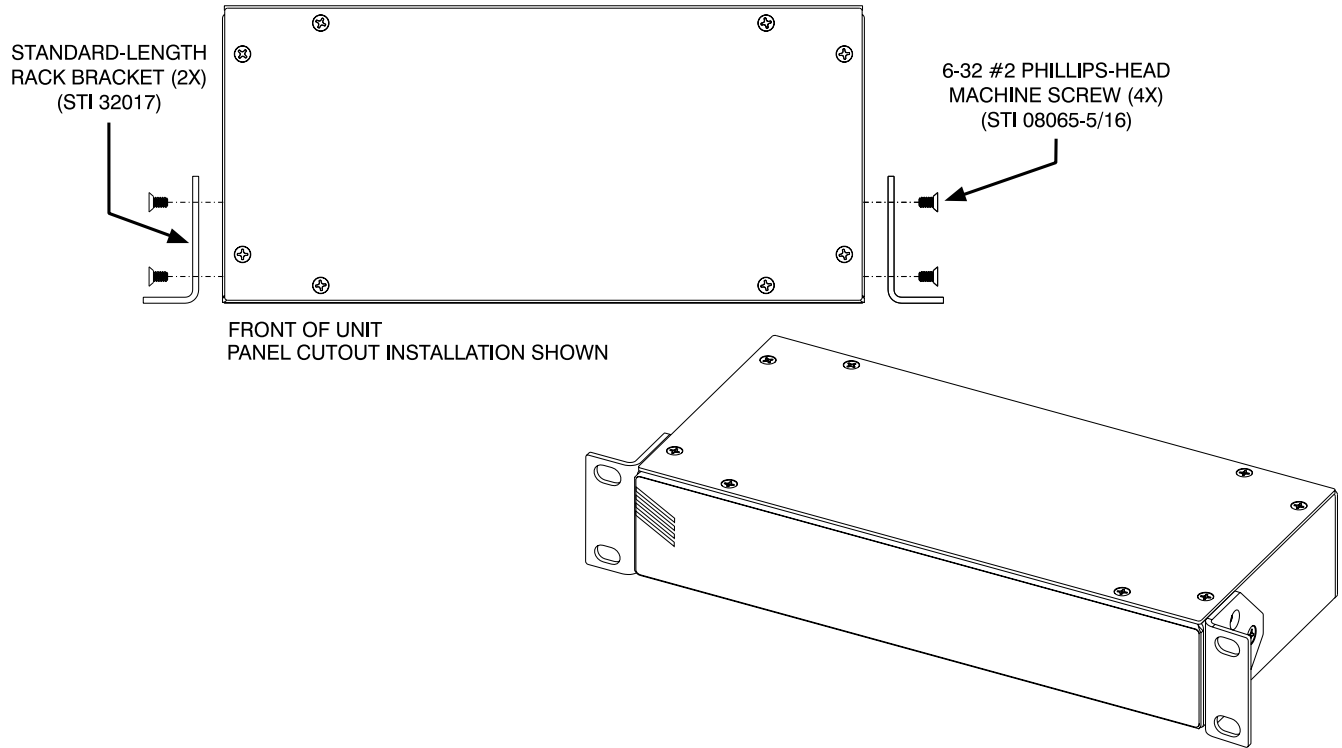

Model 5304
INTERCOM STATION

Appendix C—Graphical Description of Left- or Right-Side Rack-Mount Installation Kit for One “1/2-Rack” Unit (Order Code: *RMBK-11*)

This installation kit is used for mounting one Model 5304 unit into one space (1U) of a 19-inch equipment rack. Unit will be located on the left- or right-side of the 1U opening.

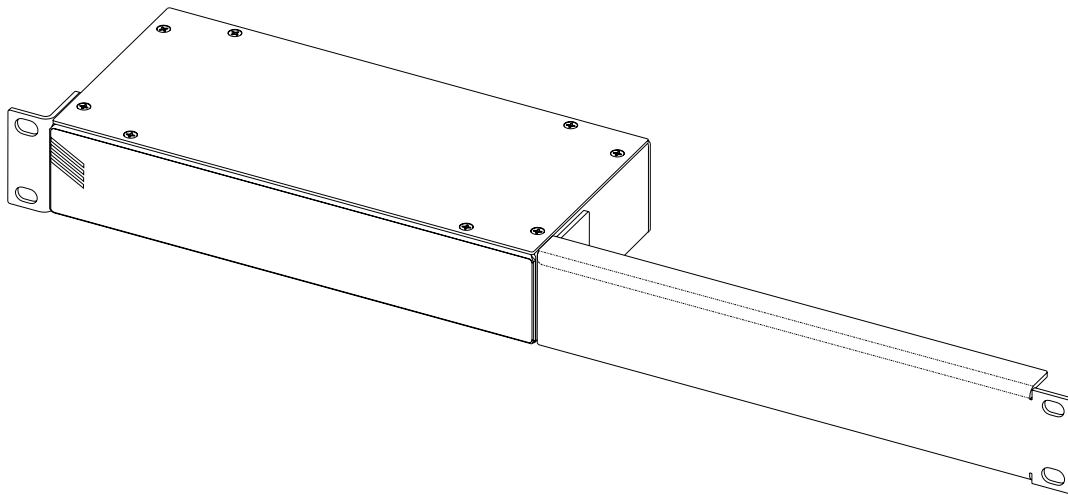
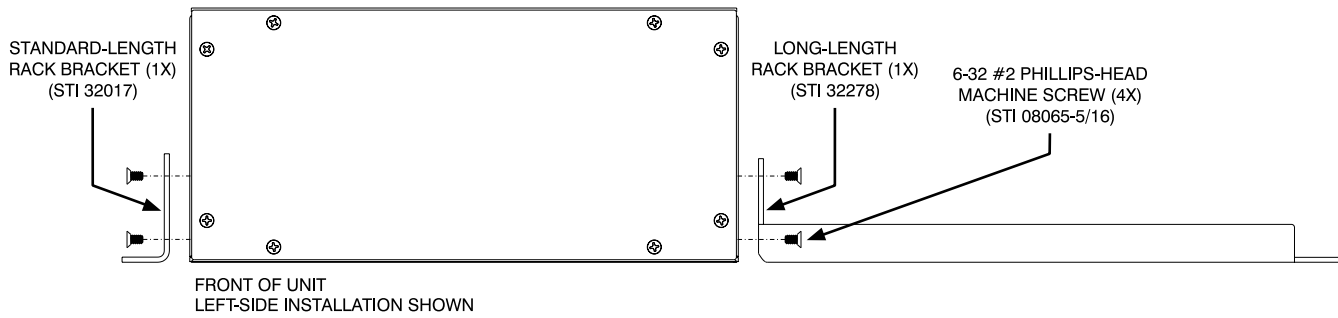

Model 5304
INTERCOM STATION

Appendix D—Graphical Description of Rack-Mount Installation Kit for Two “1/2-Rack” Units (Order Code: *RMBK-12*)

This installation kit can be used to mount two Model 5304 units or one Model 5304 unit and another product that is compatible with the RMBK-12 (such as the Studio Technologies’ Model 5421 Dante Intercom Audio Engine) into one space (1U) of a 19-inch equipment rack.

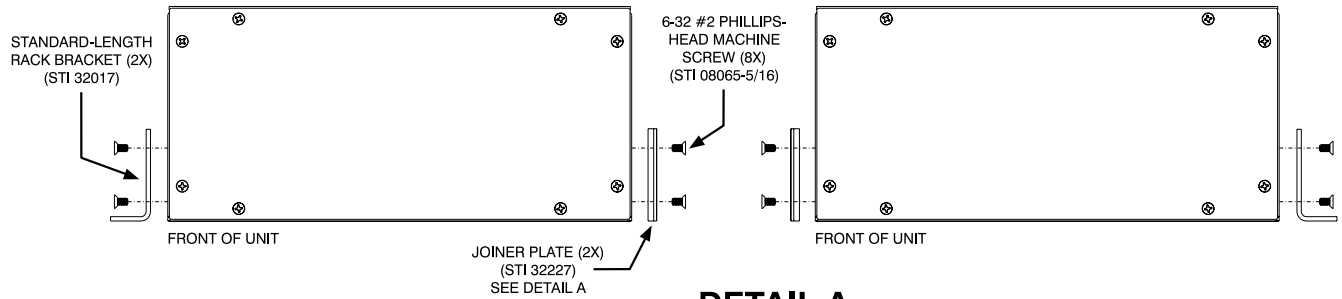

DETAIL A

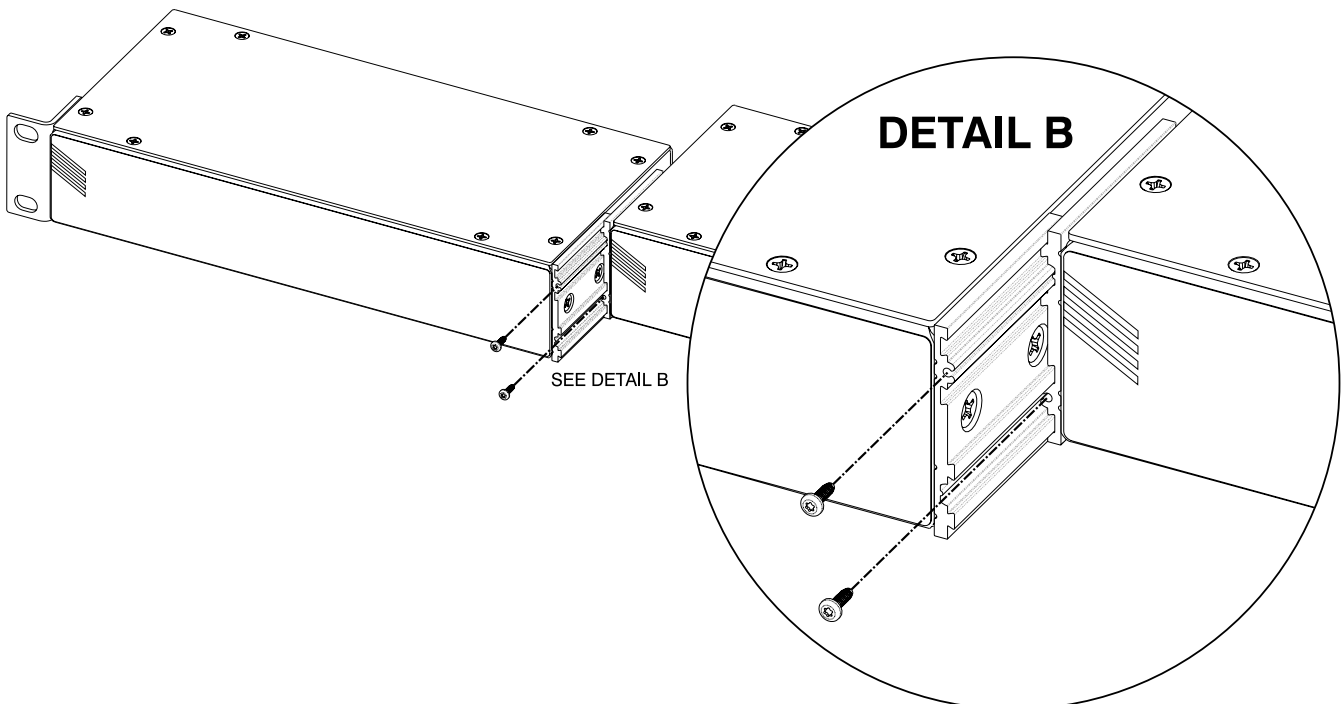
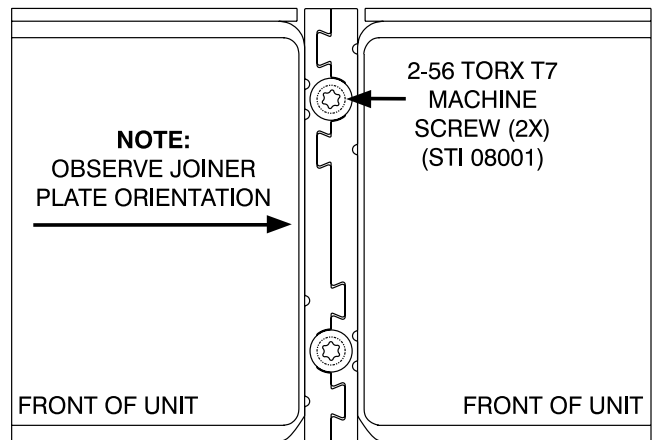

Model 5304
INTERCOM STATION

Appendix E—Graphical Description of Center Rack-Mount Installation Kit for One “1/2-Rack” Unit (Order Code: *RMBK-13*)

This installation kit is used for mounting one Model 5304 unit into one space (1U) of a 19-inch equipment rack. Unit will be located in the center of the 1U opening.

