

C400XL

DUAL STEREO GATE & COMPRESSOR



IMPORTANT SAFETY INSTRUCTIONS



The lightning flash with an arrowhead symbol within an equilateral triangle is intended to alert the user to the presence of uninsulated "dangerous voltage" within the product's enclosure that may be of sufficient magnitude to constitute a risk of electric shock to persons.



The exclamation point within an equilateral triangle is intended to alert the user to the presence of important operating and maintenance (servicing) instructions in the literature accompanying the product.

- 1 Read these instructions.
- 2 Keep these instructions.
- 3 Heed all warnings.
- 4 Follow all instructions.
- 5 Do not use this apparatus near water.
- 6 Clean only with dry cloth.
- 7 Do not block any ventilation openings. Install in accordance with the manufacturer's instructions.
- 8 Do not install near any heat sources such as radiators, heat registers, stoves, or other apparatus (including amplifiers) that produce heat.
- 9 Do not defeat the safety purpose of the polarized or grounding-type plug. A polarized plug has two blades with one wider than the other. A grounding type plug has two blades and a third grounding prong. The wide blade or the third prong are provided for your safety. If the provided plug does not fit into your outlet, consult an electrician for replacement of the obsolete outlet.
- 10 Protect the power cord from being walked on or pinched particularly at plugs, convenience receptacles, and the point where they exit from the apparatus.
- 11 Only use attachments/accessories specified by the manufacturer.
- 12  Use only with the cart, stand, tripod, bracket, or table specified by the manufacturer, or sold with the apparatus. When a cart is used, use caution when moving the cart/apparatus combination to avoid injury from tip-over.
- 13 Unplug this apparatus during lightning storms or when unused for long periods of time.
- 14 Refer all servicing to qualified service personnel. Servicing is required when the apparatus has been damaged in any way, such as power-supply cord or plug is damaged, liquid has been spilled or objects have fallen into the apparatus, the apparatus has been exposed to rain or moisture, does not operate normally, or has been dropped.

Warning!

- To reduce the risk of fire or electrical shock, do not expose this equipment to dripping or splashing and ensure that no objects filled with liquids, such as vases, are placed on the equipment.
- This apparatus must be earthed.
- Use a three wire grounding type line cord like the one supplied with the product.
- Be advised that different operating voltages require the use of different types of line cord and attachment plugs.
- Check the voltage in your area and use the correct type. See table below:

Voltage	Line plug according to standard
110-125V	UL817 and CSA C22.2 no 42.
220-230V	CEE 7 page VII, SR section 107-2-D1/IEC 83 page C4.
240V	BS 1363 of 1984. Specification for 13A fused plugs and switched and unswitched socket outlets.

- This equipment should be installed near the socket outlet and disconnection of the device should be easily accessible.
- Do not install in a confined space.
- Do not open the unit - risk of electric shock inside.

Caution:

You are cautioned that any change or modifications not expressly approved in this manual could void your authority to operate this equipment.

Service

- There are no user-serviceable parts inside.
- All service must be performed by qualified personnel.

IMPORTANT SAFETY INSTRUCTIONS

EMC / EMI.

This equipment has been tested and found to comply with the limits for a Class B Digital device, pursuant to part 15 of the FCC rules. These limits are designed to provide reasonable protection against harmful interference in residential installations. This equipment generates, uses and can radiate radio frequency energy and, if not installed and used in accordance with the instructions, may cause harmful interference to radio communications. However, there is no guarantee that interference will not occur in a particular installation. If this equipment does cause harmful interference to radio or television reception, which can be determined by turning the equipment off and on. The user is encouraged to try to correct the interference by one or more of the following measures:

- Reorient or relocate the receiving antenna.
- Increase the separation between the equipment and receiver.
- Connect the equipment into an outlet on a circuit different from that to which the receiver is connected.
- Consult the dealer or an experienced radio/TV technician for help.

For the customers in Canada:

This Class B digital apparatus complies with Canadian ICES-003.
Cet appareil numérique de la classe B est conforme à la norme NMB-003 du Canada.

Certificate Of Conformity

TC Electronic A/S, Sindalsvej 34, 8240 Risskov, Denmark, hereby declares on own responsibility that following products:

C400XL

DUAL STEREO GATE & COMPRESSOR

- that is covered by this certificate and marked with CE-label conforms with following standards:

- | | |
|----------------------|---------------------------------------------------------------------------------------------------------------------------------------------|
| EN 60065 (IEC 60065) | Safety requirements for mains operated electronic and related apparatus for household and similar general use |
| EN 55103-1 | Product family standard for audio, video, audio-visual and entertainment lighting control apparatus for professional use. Part 1: Emission. |
| EN 55103-2 | Product family standard for audio, video, audio-visual and entertainment lighting control apparatus for professional use. Part 2: Immunity. |

With reference to regulations in following directives:
73/23/EEC, 89/336/EEC

Issued in Risskov, April 2007
Mads Peter Lübeck
Chief Executive Officer

TABLE OF CONTENTS

INTRODUCTION

<i>Important safety instructions</i>	a
<i>Certificate of Conformity</i>	b
<i>Table of contents</i>	3
<i>Introduction</i>	5
<i>Front Panel overview</i>	6
<i>Rear Panel connections</i>	8
<i>Signal Flow diagram</i>	9
<i>Typical setups</i>	10
<i>Cables - (important)</i>	12

BASIC OPERATION

<i>Preset applications</i>	14
--------------------------------------	----

C400XL Processing

<i>Compression basics</i>	16
<i>Comp/Limiter mode - C400XL</i>	17
<i>Gate Expander mode - C400XL</i>	18
<i>New Style Compression - C400XL</i>	19

APPENDIX

<i>Software update</i>	20
<i>Technical specifications</i>	21

QUICK START - IF YOU JUST CAN'T WAIT

If you are familiar with compressors, limiters, gates and de-essing techniques this quick guide is probably all the information you will need to operate the C400XL. For more information, please refer to other sections of this manual.

- Unpack the C400XL and check for possible damages that could have been caused by transport.
- Read the safety instructions.
- Take a few minutes to register online via: www.tcelectronic.com or send in the registration card. Customers registered online will be notified directly via E-Mail about relevant news

The C400XL is a compressor/de-esser - gate/expander with two independent channels that can be routed either in serial (stereo) or dual mono mode.

Routing

The C400XL has two routing options. Dual Mono or Stereo/Serial. The Routing mode is set on the C400XL front panel on the far left.

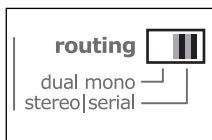

Dual mono

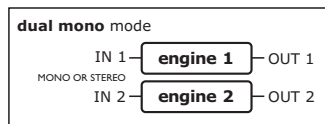

- where C400XL is split and operates as two 100% separate mono engines. A typical application for this mode is using the two engines as insert effects on two different channels.

Stereo/Serial Mode

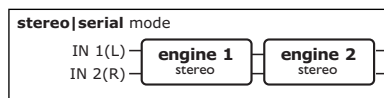

- utilizing both effect engines in serial. Engine 1 is feeding Engine 2. This is the mode to

choose if you wish to process a signal with both processing engines. Note that this routing works for both a stereo setup but also a single mono setup. Typically you would use one engine as a gate/expander and the other as de-esser or compressor/limiter. But note that any combination of effects is possible as the engines operate independently.

- Make all appropriate connections. You may refer to the examples on pages 10-11.
- Decide application and set Routing accordingly.
- Set MIX to 100% for normal compression. Any setting between 0 and 100% utilizes the C400XL "new compression style", based on parallel compression. Read the section "New Style Compression"
- Select desired processing type on the two Engines.
- Start playing.
- Feed the C400XL channels with an appropriate level. The yellow -3 LED should only be lit at peaks. The level is set on the sending device.
- Set MIX depending on your intentions and selected effect.
- Now tweak the THRESHOLD, MAKE-UP GAIN and RATIO controls for the two engines until you have the intended result.

For any questions left unanswered by this manual feel free to visit our online support center; **TC Support Interactive**, which can be accessed via: www.tcelectronic.com



Latest manual revision can always be downloaded from www.tcelectronic.com Manual revision number is found in the bottom of page 3.

INTRODUCTION

Congratulations on the purchase of your C400XL.

C400XL is a supreme Dual Gate | Compressor specially designed for audio professionals on the road as well as in the studio. Combining award-winning multiband compression technology with an extremely fast and intuitive user interface as well as a super silent click free gate, the C400XL is made for the uncompromising sound engineer.

Multiband dynamics technology

C400XL uses advanced TC Electronic multiband dynamics technology to compress and adapt to any source - from vocals and percussion to guitars and even keyboards. The inherent transparency of the multiband compressor brings out the qualities of the source material, yet secures a firm and consistent level at all times. The optimized and super-fast gate offers a click free and high precision gating of any source.

Three strikes and you're in

C400XL stands out in three distinct areas that make it the ideal unit for demanding live and studio use. First there is the sound quality – this quality is ensured by source-based multiband compression and ultra fast gating. Another great aspect of the C400XL is its versatility – adapt to any source, analog or digital, decide on gate, compression or a combination, and C400XL is up for the task at hand. And finally there is the intuitive, fast use of C400XL – source-based compression, intuitive user interface and a mix knob for parallel compression makes for a fast, professional unit.

Intuitive – yet advanced

C400XL features a TC Electronic exclusive 'Mix' knob allowing parallel compression without complicated routing schemes. The unique Parallel compression will lift hidden details in every vocal or drumkit track. To assure smooth operation, C400XL is equipped with high resolution input, gain reduction metering and threshold LED indication. Choose between true dual mono for superior channel separation, stereo or serial operation. C400XL features brickwall limiting for peak stop and hot levels prevention.

Analog and digital connectors

C400XL is the ideal choice for parallel compression, gating and/or compressor applications. A C400XL channel transforms from multiband compressor to ultra fast gate and back at a flick of a switch. Gate and compressor functions can be serial or parallel at the choice of the engineer, thus allowing e.g. awesome combinations of compressor and gate on a snare drum giving that tight and snappy impact sound. Balanced Analog (XLR) and Digital AES/EBU (XLR) connectors make C400XL the perfect solution for any pro sound engineer looking for high-end compression/gates to complement his analog or digital setup.

FRONT PANEL OVERVIEW

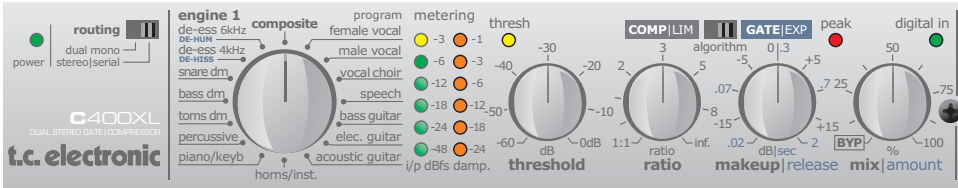

ROUTING MODE switch

Selects between the following routing modes:

Dual Mono routing mode

The two engines operate 100% individually and can be perceived as two separate mono units.

Stereo/Serial routing mode

This mode can be used for several different application setups:

Serial mono:

By using only the Left input/Left output, C400XL operates as two mono blocks in serial.

Serial Stereo:

Connecting a stereo signal on Left/Right inputs the two engines can be used as two stereo devices in serial.

Stereo:

Engine 2 is bypassed by setting MIX to "bypass" (fully counter-clockwise) and Engine 1 is used as a stereo effect. Only one engine is applied.

The following descriptions of controls are valid for both Engines 1 and 2.

PRESET selector

Use the PRESET selector to select the desired source preset for Engine 1.

METERS

I/P dB:

Input meter showing the signal present on the input. Analog or digital. Meters indicate dBFS.

Damp meter:

Indicates the attenuation of the signal in dB.

THRESH LED (Threshold LED)

In presets using Multi-band compression:

The LED can indicate two scenarios.

- When the input signal level exceeds the set threshold.
- When the input signal triggers the Peak Limiter.

In presets using Gate/Expander mode:

LED on = signal above threshold

LED off = signal below threshold

PEAK

The PEAK LED can indicate various types of overload.

LED will be on if:

- The incoming digital or analog signal is too hot. Reduce the source signal.
- Internal overload in the digital domain. This situation occurs if the applied make up gain is set too high. This situation should not occur under normal working conditions.

THRESHOLD

Sets the threshold for the selected preset. The threshold should be set according to the level of the processed signal. The lower the threshold is set, the earlier the processing is applied.

RATIO

Sets the ratio for the selected engine preset.

MAKEUP / RELEASE

For compression presets this control sets the make-up gain. The release times are predefined in the presets.

For Gate/Expander presets this control sets the release time.

FRONT PANEL

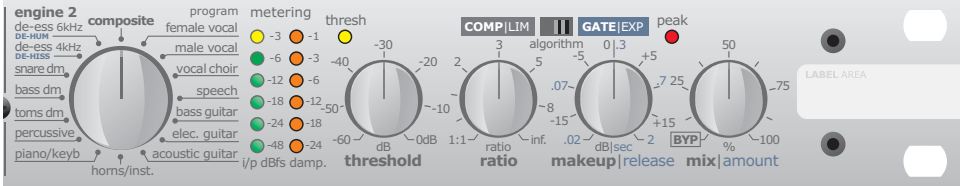

MIX / AMOUNT

For compression effects the MIX/AMOUNT knob controls the mix between the processed and the direct signal. When set to 0% the engine is 100% bypassed.

In Gate /Expander mode the knob controls the amount of damping.

REAR PANEL CONNECTIONS



**Balanced
XLR
Analog
Inputs**

**XLR
Analog
Outputs
(pseudo
balanced)**

**Digital
In/Out**

**MIDI
In/Out**

**Power Input
100 - 240VAC**

Inputs

Balanced analog inputs on XLR connectors.

Outputs

Pseudo balanced analog outputs on XLR connectors.



Please read the manual section on correct cables to use with C400XL on pages 12-13.

Digital I/O

24 bit digital AES/EBU input and output on standard XLR connectors.

C400XL automatically detects if a digital signal is present on the AES/EBU input. When locked to a valid digital signal the DIGITAL IN LED on the front panel is lit.

If C400XL cannot lock to the digital input the analog inputs are used.

MIDI In - MIDI Out

MIDI in/out for uploading software.

Power

100-240 VAC switchmode power supply. The C400XL accepts any voltage from 100 to 240 VAC.

SIGNAL FLOW

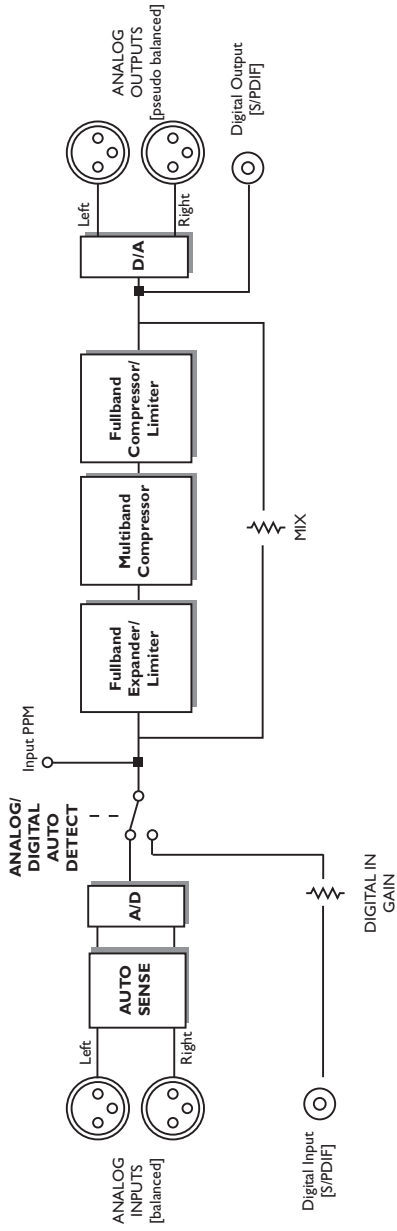

TYPICAL SETUPS

Insert

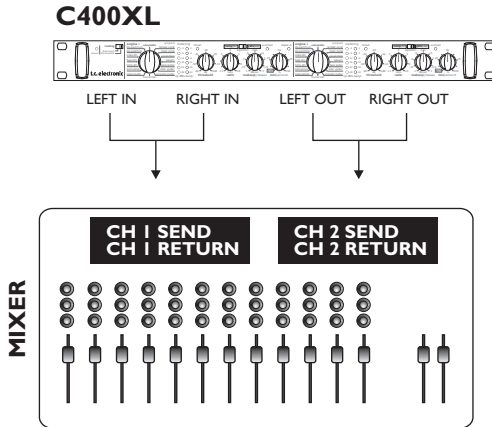

In this example the C400XL is used in Dual Mono mode as two 100% independent mono engines on two separate channels. The two engines have no influence on each other.

The illustration above shows connections in an analog setup. If digital input is used the two channels present on AES/EBU is split and processed exactly as two signals were connected to the Left inputs on engines 1+2 as illustrated above.

Purpose: Individual processing on two separate channels.

- Set routing to “dual mono” mode.
- Insert C400XL engine 1 using a Y-split cable (or other appropriate cable).
- Insert C400XL engine 2 using a Y-split cable (or other appropriate cable).

For each engine:

- Select processing type for engines 1 and 2.
- If you have selected a compression type preset set the Makeup gain to 12 o'clock position.
- Set Threshold and Ratio controls.
- Set mix to 100% for conventional full signal processing or use a lower setting to utilize the “new style compression”/parallel compression. (read more on new style compression later in this manual)
- Now adjust the Makeup gain for level compensation.

TYPICAL SETUPS

Stereo / Serial

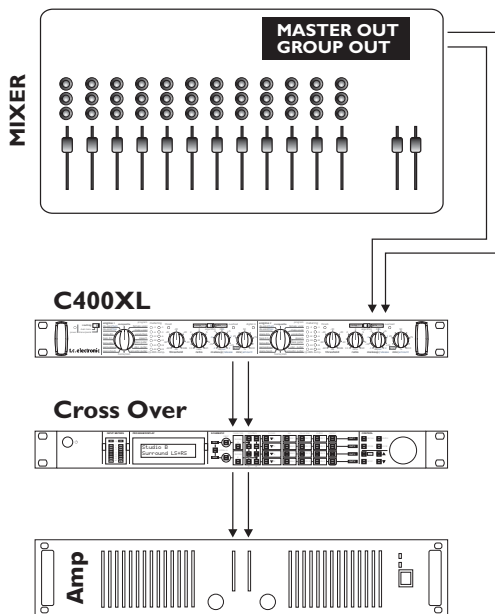

In the Stereo/Serial mode C400XL is ideal for the following 3 different main applications.

Mono serial processing

Connect a mono signal to the C400XL left input and listen on the C400XL left output.

Stereo (single engine processing)

Stereo in / Stereo Out. Bypass engine 2 by turning the MIX control fully counter-clockwise to "BYP".

Stereo Serial (dual engine processing)

Stereo in / Stereo Out. Both engines processing. This is a typical choice if you want to combine e.g. a De-ess function with compression on vocals.

- Set Routing to Stereo / Serial.
- Connect Master Out or Group Out to C400XL Left/Right inputs and C400XL outputs to downstream device - e.g. stereo amplifier.

For each engine:

- Select processing type for engines 1 and 2. Bypass Engine 2 for Stereo single engine processing.
- If you have selected a compression type preset set the Makeup gain to 12 o'clock position.
- Set Threshold and Ratio controls.
- Set mix to 100% for conventional full signal processing or use a lower setting to utilize the parallel compression. (read more on parallel compression later in this manual)
- Now adjust the Makeup gain for level compensation.

CABLES

Type 1 - Mixer Send/Return “ground sensing” split cable

Many mixing consoles do not feature balanced insert points and thereby downgrade these signals compared to the balanced main inputs. The result is potential hum and noise induced when using standard insert cables. To eliminate this noise the C400XL has special designed ground sensing inputs and outputs, which are "enabled" by using a ground-sensing split cable.

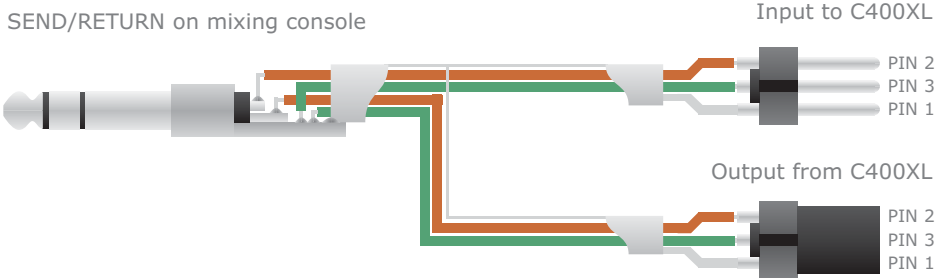

Type 2 - Standard balanced XLR to XLR

Use this cable type if you are connecting to a mixer with true balanced insert points on XLR.



CABLES

Type 3

Unwanted hum and noise can be introduced if you connect the outputs of C400XL to unbalanced equipment using a standard XLR to TRS (type 3a). If this is the case it is most likely because the ring-connection is floating/unconnected inside the device you are connecting to.

In that case use an XLR to TS cable (type 3b) where ring (pin 3 connection) is connected to the sleeve. You can also use a TRS to TS adapter that connects ring to sleeve.

Type 3a



Type 3b



PRESET APPLICATIONS

This chapter describes the C400XL presets and their suggested applications. You are of course encouraged to experiment and twist controls to reach an optimal result for your specific application.

Composite

Use the composite preset when you have a complex or multi faceted signal like a full-mix signal. You can use it in both compressor and expander mode. The C400XL does the work for you – what was previously a complex operation has now become a simple operation thanks to the optimized composite preset.

*Applied algorithm in Comp/Lim mode:
Multi-band Compression + Peak Limiter*

*Applied algorithm in Exp/Gate mode:
Wideband Expansion*

Female vocal

The female vocal preset is tailor made for high pitched vocals. In compression mode it will bring out the sonic qualities of your taste. You'll immediately be amazed about the audible perfection you can attain with this multi-band preset.

*Applied algorithm in Comp/Lim mode:
Multi-band Compression + Peak Limiter*

*Applied algorithm in Exp/Gate mode:
Wideband Expansion*

Male vocal

Male vocals often becomes a bit muddy due to their lower pitch. For optimal clarity and performance, you should apply this multi-band compression preset, which brings out the true essence of your vocals.

*Applied algorithm in Comp/Lim mode:
Multi-band Compression + Peak Limiter*

*Applied algorithm in Exp/Gate mode:
Wideband Expansion*

Voc. Choir

If you want your backing vocals to stand out, while preserving the "group-like" character that a band of singers have, the Voc. Choir preset will do the job. Use the compressor to control the gain of your source or use the expander to lower the noise floor.

*Applied algorithm in Comp/Lim mode:
Multi-band Compression + Peak Limiter*

*Applied algorithm in Exp/Gate mode:
Wideband Expansion*

Speech

For pure speech and oratory signals, you should use the Speech preset. It is optimized for signals with a lesser dynamic fluctuation than what you'll find in e.g. vocals on a musical track. The preset is a multi-band compression/wideband expansion preset in respectively compressor/expander modes.

*Applied algorithm in Comp/Lim mode:
Multi-band Compression + Peak Limiter*

*Applied algorithm in Exp/Gate mode:
Wideband Expansion*

Bass guitar

One thing that all bass players hate, is unintentional muddy-ness to their sound. The bass guitar preset ensures that your bass is "smack in the face". Apply this multi-band compressor for great results on your bass sound retaining the sonic qualities of your entire signal.

*Applied algorithm in Comp/Lim mode:
Multi-band Compression + Peak Limiter*

*Applied algorithm in Exp/Gate mode:
Wideband Expansion*

Electric guitar

Most often electric guitars have no problem cutting through in the mix. However, controlling both low, mid and high frequency peaks often is often essential to getting a homogenous result. Multiband compression is a great but often overseen tool for guitars. Guitars system are due to their nature also very often related to a high amount of noise. Therefore a gate/expander is a standard too when processing guitars. C400XL delivers both.

*Applied algorithm in Comp/Lim mode:
Multi-band Compression + Peak Limiter*

*Applied algorithm in Exp/Gate mode:
Wideband Expansion*

PRESET APPLICATION

Acoustic guitar

Acoustic guitars have a subtleness that is delightful to listen to. Yet sometimes subtleness is interchangeable with a lesser presence in the mix. The multi-band Acoustic Guitar preset gives you a compressor that will preserve the original subtleness and evenness of your instruments tone, and an expander that will lower the noise floor.

*Applied algorithm in Comp/Lim mode:
Multi-band Compression + Peak Limiter*

*Applied algorithm in Exp/Gate mode:
Wideband Expansion*

Horns/instrument

A horn section or for that matter a solo sax, can be quite a hassle to get just right in the mix. Apply the Horns/instrument preset and take advantage of a true multi-band compressor. Use the compressor to align the difference in volume that you will find in e.g. a fast riff as compared to sustained tones.

*Applied algorithm in Comp/Lim mode:
Multi-band Compression + Peak Limiter*

*Applied algorithm in Exp/Gate mode:
Wideband Expansion*

Piano/keyb

Synthesizers, stage-pianos and acoustic pianos have a huge pitch and dynamic range. That makes it genuinely hard to find just the right level for such instruments in the mix. For exceptional control and equality you should apply the Piano/keyb preset.

*Applied algorithm in Comp/Lim mode:
Multi-band Compression + Peak Limiter*

*Applied algorithm in Exp/Gate mode:
Wideband Expansion*

Percussive

A full set of percussion instruments has a huge dynamic range that is very difficult to control. With the Percussive preset you can avoid any surprises that powerful and darker percussive instruments might dish out, giving you total control of the dynamic range.

*Applied algorithm in Comp/Lim mode:
Full-band Compression*

*Applied algorithm in Exp/Gate mode:
Wideband Expansion*

Toms dm - Toms “drum”

Tom toms span from small and higher pitched sounds to large and lower pitched sounds. Their relatively high attack and short decay times requires advanced mixing techniques. With the Toms preset you have a specially designed Multi-band Compressor and Wideband Gate/Expander.

*Applied algorithm in Comp/Lim mode:
Full-band Compression*

*Applied algorithm in Exp/Gate mode:
Wideband Gate/Expansion*

Bass dm - Bass drum

The bass drum plays many different roles. Depending on the style of music, you want it to be hard and powerful, full and punchy, or fast and furious.

*Applied algorithm in Comp/Lim mode:
Full-band Compression*

*Applied algorithm in Exp/Gate mode:
Wideband Gate/Expansion*

Snare dm - Snare drum

You've probably already experimented with the sound of the snare drum, in the quest for that signature sound that some of the world's great drummers are known for. With the Snare dm preset you're on the fast track to making your snare drum sound exceptional.

*Applied algorithm in Comp/Lim mode:
Full-band Compression*

*Applied algorithm in Exp/Gate mode:
Wideband Gate/Expansion*

PRESET APPLICATION

De-Hiss

Sometimes you might get a bit of hiss from an incoming source, especially when external devices are linked into a larger setup or if different electronic formats or ground policies are connected like consumer standards connected to professional equipment. To counter that you should use the De-Hiss preset. It kicks in when there is no or next to no level on the input source, ensuring no noise in quiet pieces of the music. This preset is only featured in the gate/expander mode.

*Applied algorithm:
Multi-band Expansion*

De-Hum

As explained in the De-Hiss preset description you can occasionally experience problems with hum in an incoming signal when you connect different types of devices. In quite moments when the hum becomes a problem the hum can in a smooth and easy way be eliminated by using the De-Hum preset simply by adjusting the parameters. The preset can only be used in gate/expander mode.

*Applied algorithm:
Multi-band Expansion*

De-ess 4kHz

The De-ess 4kHz preset removes all unwanted s's that some microphones or singers have so much trouble with. You can use the De-ess 4kHz preset in compressor/limiter mode only. It aims at a certain frequency range and it perfectly counterparts the De-ess 6khz preset.

*Applied algorithm:
Multi-band Compression*

De-ess 6khz

The De-ess 6kHz preset removes all unwanted s's that some microphones or singers have so much trouble with. You can use the De-ess 6khz preset in compressor/limiter mode only. It aims at a certain frequency range and it perfectly counterparts the De-ess 4kHz preset.

*Applied algorithm:
Multi-band Compression*

C400XL PROCESSING

Compression

The very basis of compression can be reduced to "controlling the dynamic content" of an audio signal. This basically means turning down the loudest parts of the source material and raising the volume of the parts with low level content. But how this is done and how this is applied in audio production is slightly more elaborate.

Keep an eye on the illustration below and let us look at the basic compression parameters:

The Threshold parameter - sets the limit where the compressor kicks in/releases its grip of the signal. As soon as the level is above the set threshold the compressor is active. When below - it is not.

The Ratio - sets the amount of gain reduction applied when the signal exceeds the threshold. In the illustration below the Ratio is the steepness of the curve after the compressor threshold.

The Attack time - is the time it takes for the compressor to reach the compression amount specified by the set ratio.

The Release time - is the time it takes for the compressor to release the signal after the input signal is below the threshold point again.

How each of these parameters are set is very important and only the correct combination gives the desired result.

The C400XL presets assist you greatly in that respect as each preset has pre-programmed attack and release times.

Makeup gain - is a common control on compressors. As reducing/controlling the loudest parts of the signal attenuates the signal it is most often necessary to increase the overall output volume. Thereby the elements with lowest dynamic content are enhanced.

The Limiter - the Limiter is actually yet another compressor. It uses a very fast attack time and has a ratio of 1; infinity. But why is the Limiter necessary?

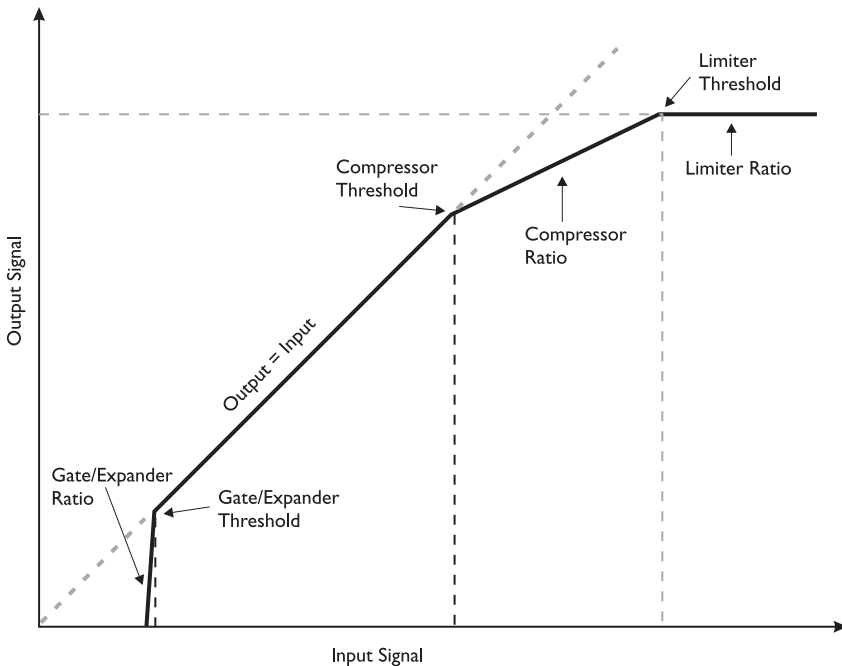

C400XL PROCESSING

For the compressor to be used as a musical tool the set attack times are relatively long. (from 10 to 200ms) This gives the disadvantage that certain peaks can pass. Therefore a limiter with an attack time of as little as 0.1ms and a ratio of 1:infinity prevents close to all overshoots.

For different purposes there are different Limiter types. The C400XL limiter is a peak type limiter and it is automatically active on all preset types using the multi-band compression style. (see pages 14-15).



Though a peak limiter is applied on all multiband compression presets (not on de-ess presets), it is worth noticing that C400XL holds an exceptional tolerant headroom structure. In combination with the Peak Limiter that ensures that occasional peaks are tamed you can actually operate very close to max without any risks of overshoots.

Comp/Lim mode - C400XL

Wideband Compressor

The wideband/fullband compressor type is applied in the drum presets. The compression is triggered by the entire signal.

Multiband Compressor

Where the wideband compressor excels in limited frequency areas the multi-band compression excels on more complex preset material with a wider frequency range. This being both composite material but also sources such as vocals, horns and guitar that despite their immediate simple structure can suffer from the "breathing syndrome" where the compression of the lower frequency bands ends up controlling the upper frequencies also.

The multi-band compression style splits the signal in three frequency areas and compresses these bands individually. Attack and Release settings are prepared and tuned on the C400XL presets giving you excellent starting points. Threshold and Ratio are set on the front.

De-Ess

The De-Ess presets also utilize the multi-band compression type and is fine-tuned to reduce sibilance from "s" sounds that can be far too dominant.

Gate/Expander mode - C400XL

Set the mode selector to "GATE/EXP" position.



Noise, whether it is hiss, hum or just background noise is always a parameter to evaluate and deal with. Initially noise must of course be reduced to a minimum from the source, but with a Gate/expander it is also possible to reduce the noise on channels when no significant signal is present.

Basics

A Gate - or downward expander, - is used to attenuate the signal when the signal is below a certain threshold. When talking about attack and release times in reference to a noise gate: - the attack time is the time it takes to for the gate to "open" when the signal rises above the threshold and...

- the release time is the time it takes for the gate to reach the specified attenuation.

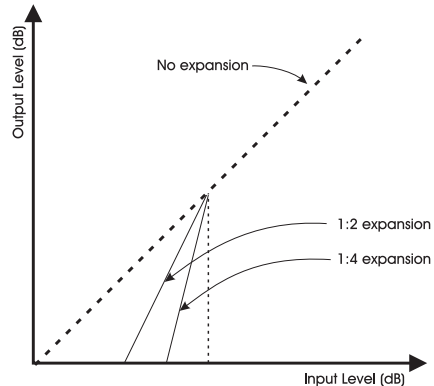

C400XL Gate presets

All presets except for Hiss/Hum trigger dedicated Gate/Expander settings tuned to the various preset materials.

Hiss & Hum presets

Dedicated presets for hiss and hum elimination.

C400XL PROCESSING

C400XL - New style compression

- an innovative approach to compression

Do you recognize the situation where you read about a technology, maybe even in details, and feel that you really understand the concept?

Then, once you are in a stressed environment and try to apply you new found wisdom you loose the overview and though it looked really good on paper you now don't seem to pull its full potential.

Parallel compression could actually be one those "understandable when read" technologies that you tend to mess up in a real life situation.

With the C400XL New Style Compression NSC™ you can avoid this unsatisfactory situation. C400XL gives you a totally new approach and some stunning results based on the thoughts behind parallel compression in a one touch operation with no unintended side effects.

Furthermore you don't have to deal with complex un-tweakable relations between time constants, gain structures and ratio settings. The optimized presets do the job for you. Just add music, tweak a few parameters and you are flying.

Parallel Compression

As described earlier, compression is a matter of controlling the peaks in the signal in a way that doesn't decrease the quality of the incoming audio signal. An example could be if you experience peaks in the vocal or the instrument signal that changes the feeling of the incoming source's position in the final mix, or if the preset materials you are working with are way too different in volume. A good example would be a snare drum drum with various outputs from beat to beat.

Or how about the situation where you have an extremely dynamic vocal with significant differences from the highest to the lowest peaks. At the same time you want to enhance the singer's breath and the low-end frequencies to make it more present and sounding as if the singer is just a few inches away.

You still want to maintain the signal's dynamic range and keep the peaks in the signal to make

it more musical to listen to.

How is this done?

Well the answer is complex parallel compression. Normally this is setup on the mixing console.

When setting up a traditional "parallel compression", you

- route the direct and uncompressed signal to a stereo bus (bus A)
- simultaneously you route the signal to a stereo bus with a stereo compressor inserted.
- then you route the processed signal to bus A also.

Seems pretty simple, but there are definitely downsides to that method. - If you make any level changes on the compressed or the direct signal it will affect your stereo mix due to the lack of level-compensation in the two signals. Also - you cannot mix digital and analog devices in the chain unless time-align all signals correctly. So there are several pitfalls that invites to mistakes, - especially in stressed situations.

DON'T WORRY. The C400XL New Style Compression will assist you in setting up parallel compressions fast and easy. A unique feature that so far is unseen in a compact unit.

The main object

- is mixing the unprocessed signal with the compressed signal. Mixing is easily done using the MIX knob. Setting MIX to 100% lets the C400XL operate as a regular compression. Setting MIX in any position between bypass and 100% applies "new style compression".

Why?

What does it do to the sound? The higher dynamics are better preserved and at the same time the details from the lower dynamic parts of the signal.



- Try to apply parallel compression on a drum kit. You will discover that all the lower details are smack in the face, while all the bells and high dynamics of the snare and cymbals are preserved and "uncompressed", so to speak.

SW Update

Updating the C400XL software is easy.
Download the software application from
www.tcelectronic.com.

Connect the computers MIDI out to C400XL
MIDI in. C400XL is always ready to receive
such a software update.

APPENDIX - TECHNICAL SPECIFICATIONS

Digital Input and Output

Connector:	XLR (AES/EBU)
Formats:	AES/EBU (24bit)
Sample Rates:	48 kHz. (44.1 kHz only @ Digital Input)
Processing Delay:	0.08 ms @ 48 kHz
Frequency Response DIO:	DC to 23.9 kHz \pm 0.01 dB @ 48 kHz

Analog Inputs

Connectors:	XLR balanced (pin 2+, pin 3-)
Impedance, Bal / Unbal:	20 kOhm / 11 kOhm
Max. Input Level @ 0 dBFS:	+21 dBu
A to D Conversion:	24 bit, 128 x oversampling bitstream
A to D Delay:	0.9 ms @ 48 kHz
Dynamic Range:	Typ < -110 dB, 22 Hz to 22 kHz
THD:	Typ < -102 dB (0.0008 %) @ 1 kHz, -1 dBFS
Frequency Response:	+0/-0.1 dB, 20 Hz to 20 kHz
Crosstalk:	Typ < -115 dB, 20 Hz to 20 kHz

Analog Outputs

Connectors:	XLR balanced (pin 2+, pin 3-)
Max. Output Level:	+21 dBu
D to A Conversion:	24 bit, 128 x oversampling bitstream
D to A Delay:	0.58 ms @ 48 kHz
Dynamic Range:	typ < -110 dB typ, 22 Hz to 22 kHz
THD:	typ < -94 dB (0.002 %) @ 1 kHz, +21 dBu
Frequency Response:	+0/-0.1 dB, 20 Hz to 20 kHz
Crosstalk:	typ < -100 dB, 20 Hz to 20 kHz

EMC

Complies with:	EN 55103-1 and EN 55103-2 FCC part 15, Class B, CISPR 22, Class B
----------------	-------------------------------------------------------------------

Safety

Certified to:	IEC 65, EN 60065, UL6500 and CSA E60065
---------------	-----------------------------------------

Environment

Operating Temperature:	32° F to 122° F (0° C to 50° C)
Storage Temperature:	-22° F to 167° F (-30° C to 70° C)
Humidity:	Max. 90 % non-condensing

Control Interface

MIDI:	In/Out: 5 Pin DIN
-------	-------------------

General

Finish:	Anodized aluminum front. Plated and coated steel chassis
---------	----------------------------------------------------------

Meter:

Dimensions:	2 x 6 LED's in each channel
Weight:	19" x 1.75" x 4.2" (483 x 44 x 105.6 mm)
	3.3 lb. (1.5 kg)

Mains Voltage:

	100 to 240 VAC, 50 to 60 Hz (auto-select)
Power Consumption:	<15 W
Warranty Parts and labor:	1 year

Due to continuous development these specifications are subject to change without notice.