

TANNOY®



OWNER'S MANUAL

1.0: INTRODUCTION

2.0: UNPACKING

3.0: CONNECTORS/CABLING

4.0: POLARITY CHECKING

5.0: AMPLIFICATION & POWER HANDLING

6.0: CROSSOVERS

7.0: EQUALISATION

8.0: DIMENSIONS

9.0: PERFORMANCE DATA

10.0: TECHNICAL SPECIFICATIONS

11.0: RIGGING & SUSPENSION	11.1	General Safety Advice
	11.2	Secur - ET V6Y Yoke bracket
	11.3	Secur - ET VCB2 & VCB4
	11.4	Secur - ET VCS Ceiling Saddle
	11.5	Secur - ET V8B Wall Mounting Bracket

12.0: SYSTEM CONFIGURATION & OEM CONTROLLERS

13.0: V6 RECOMMENDED SERVICE PARTS & ACCESSORIES

14.0: WARRANTY

15.0: DECLARATION OF CONFORMITY

1.0: INTRODUCTION

Featuring a high power 150mm (6") Dual Concentric™ drive unit with Tannoy's unique point source technology, the Tannoy V6 provides a compact solution for high quality music and speech reproduction. Installation, in even the smallest of venues, is made simpler due to the 90 degree conical dispersion of the Dual Concentric™ which allows either vertical or horizontal mounting without affecting sound quality or compromising performance.

The V6 comprises one 150mm (6") Dual Concentric™ driver in which the low frequency (LF) and high frequency (HF) sources are coincidentally aligned to a point source, resulting in a smooth uniform frequency response over a wide area. The sophisticated CAD designed waveguide combines 90 degree conical dispersion and excellent acoustic impedance characteristics.

As a foreground system, installation is made simple with a range of Secur-ET mounting hardware, designed specifically for the V series. As a versatile low profile stage monitor, the conical coverage pattern gives the performer greater freedom of movement than allowed by conventional horn loaded designs.

The V6 has been designed for use with the Tannoy TX1 controller, which will equalise the system resulting in improved bass performance as well as providing a 2-way crossover function, for use with separate sub-bass systems.

2.0: UNPACKING

Every Tannoy V6 product is carefully tested and inspected before being packaged and leaving the factory. After unpacking your loudspeaker, please inspect for any exterior physical damage, and save the carton and any relevant packaging materials in case the loudspeaker again requires packing and shipping. In the event that damage has been sustained in transit notify your dealer immediately.

3.0: CONNECTORS/CABLING

The V6 is fitted with two 4mm binding posts and a 4-pole Neutrik Speakon¹ for connection to the amplifier. These are paralleled within the enclosure.

The two binding post terminals are capable of accepting cables with a conductor of up to 6mm.

Red is Positive
Black is Negative

Speakon has the following advantages over EP and XLR type connectors: All terminations are solderless; this makes life easier at the time of installation or when field servicing is required. Contacts will accept 6 sq. mm wire with an outside diameter of up to 15mm and a current rating of 30 Amps. The pins of the 2 Speakon sockets identified input/output on the rear of the input panel are paralleled within the enclosure. Tannoy have adopted the conventional wiring standard for the V6 product:

Pin 1+ is Positive
Pin 1- is Negative

For a worldwide list of Neutrik distributors see <http://www.neutrik.com/>

Cable choice consists mainly of selecting the correct cross sectional area in relation to the cable length and the load impedance. A small cross sectional area would increase the cables series resistance, inducing power loss and response variations (damping factor).

Connectors should be wired with a minimum of 2.5 sq. mm (12 gauge) cable. This will be perfectly satisfactory under normal conditions. In the case of very long cable runs the wire size should exceed this, refer to the following table for guidance:

CABLE RUN (m)	C.S.A. OF EACH CONDUCTOR (mm)	CABLE RESISTANCE	% POWER LOSS INTO 8 LOAD	% POWER LOSS INTO 4 LOAD
10	2.5	0.14	1.7	3.5
	4.0	0.09	1.1	2.2
	6.0	0.06	0.73	1.5
25	2.5	0.35	4.3	8.6
	4.0	0.22	2.7	5.4
	6.0	0.14	1.8	3.6
50	2.5	0.69	8.6	17.0
	4.0	0.43	5.4	11.0
	6.0	0.29	3.6	7.2
100	2.5	1.38	17.0	35.0
	4.0	0.86	11.0	22.0
	6.0	0.58	7.2	14.0

4.0: POLARITY CHECKING

It is most important to check the polarity of the wiring before the speaker system is flown. A simple method of doing this without a pulse based polarity checker for LF units is as follows: Connect two wires to the +ve and -ve terminals of a PP3 battery. Apply the wire which is connected to the +ve terminal of the battery to the speaker cable leg which you believe to be connected to pin 1+ of the speaker connector and likewise the -ve leg of the battery to pin 1-.

If you have wired it correctly the LF drive unit will move forward, indicating the wiring is correct. All that remains now is to connect the +ve speaker lead to the +ve terminal on the amplifier and the -ve lead to the -ve terminal on the amplifier. If however the LF driver moves backwards, the input connections need to be inverted.

If problems are encountered, inspect the cable wiring in the first instance. It should also be noted that different amplifier manufacturers utilise different pin configurations and polarity conventions, if you are using amplifiers from more than one manufacturer, check the polarity at the amplifiers as well as the loudspeakers.

5.0: AMPLIFICATION & POWER HANDLING

As with all professional loudspeaker systems, the power handling is a function of voice coil thermal capacity. Care should be taken to avoid running the amplifier into clip (clipping is the end result of overdriving any amplifier). Damage to the loudspeaker will be sustained if the amplifier is driven into clip for any extended period of time. Headroom of at least 3dB should be allowed. When evaluating an amplifier, it is important to take into account its behaviour under low impedance load conditions. A loudspeaker system is highly reactive and with transient signals it can require more current than the nominal impedance would indicate.

Generally a higher power amplifier running free of distortion will do less damage to the loudspeaker than a lower power amplifier continually clipping. It is also worth remembering that a high powered amplifier running at less than 90% of output power generally sounds a lot better than a lower power amplifier running at 100%. An amplifier with insufficient drive capability will not allow the full performance of the loudspeaker to be realised. (See technical specifications section for recommended amplifier power)

It is important when using different manufacturers amplifiers in a single installation that they have very closely matched gains, the variation should be less than +/- 0.5dB. This precaution is important to the overall system balance when only a single active crossover is being used with multiple cabinets; it is therefore recommended that the same amplifiers be used throughout.

6.0: CROSSOVERS

The V6 is supplied as standard for passive operation via the internal crossover network. If higher peak outputs and additional low frequency output is required then the V6 can be used in conjunction with the Tannoy TX1 controller/crossover which provides high pass filtering and a degree of parametric equalisation, as well as a fixed crossover point for use with sub-bass loudspeakers (See the TX1 user manual for further information). The Tannoy TDX2 Digital controller will also perform the above functions with additional control and features including limiting and delay (See the relevant literature on the TDX2 for further information).

7.0: EQUALISATION

The V6 loudspeaker is designed to need no equalisation or correction to overcome system limitations. As a result, it will only need equalisation to compensate for difficult acoustic environments.

Over equalisation can reduce system headroom, and introduce phase distortion resulting in greater problems than cures. If equalisation is required then it should be applied gently and smoothly. The V6 loudspeaker is a point source, phase coherent designs and violent equalisation will be detrimental to the overall sound quality.

The Tannoy SecureET™ hardware covered in this guide has been designed to offer quick, simple, cost effective and secure solutions for mounting specific Tannoy professional loudspeakers. This hardware has been designed and manufactured with a high safety load factor for its specific role. To ensure the safest possible use of the hardware covered in this guide, it must be assembled in strict accordance with the instructions specified. The information in these manuals relating to the assembly and the safe use of these accessories must be understood and followed. The installation of Tannoy professional loudspeakers using the dedicated hardware should only ever be carried out by fully qualified installers, in accordance with all the required safety codes and standards that are applied at the place of installation.

WARNING: As the legal requirements for flying change from country to country, please consult you local safety standards office before installing any product. We also recommend that you thoroughly check any laws and bylaws prior to commencing work.

Tannoy SecureET™ professional hardware has been designed for use with specific Tannoy V Series loudspeakers, and is not designed or intended for use with any other Tannoy Professional products, or any other devices. Using Tannoy SecureET™ hardware for any purpose other than that indicated in this guide is considered to be improper use. Such use can be very dangerous as overloading, modifying, assembling in anyway other than that clearly stated in the manual, or damaging Tannoy SecureET™ hardware will compromise safety.

The component parts of any Tannoy SecureET™ hardware device must only be assembled using the accessory kits supplied and in strict compliance with the user manual. The use of other accessories or non-approved methods of assembly may result in an unsafe hardware system by reducing the load safety factor. Welding, or any other method of permanently fixing hardware components together or to the integral fixing points in the cabinet should never be used.

Whenever a Tannoy professional loudspeaker is fixed to a surface using a Tannoy SecureET™ hardware device, the installer must ensure that the surface is capable of safely and securely supporting the load. The hardware employed must be safely, securely, and in accordance with the manual, attached both to the loudspeaker and also to the surface in question, using only the fixing holes provided as standard and covered in the manual. Secure fixings to the building structure are vital. Seek help from architects, structural engineers or other specialists if in any doubt.

All loudspeakers flown in theatres, nightclubs, conference centre or other places of work and entertainment must, be provided with an independent, correctly rated and securely attached secondary safety - in addition to the principle hardware device. This secondary safety must prevent the loudspeaker from dropping more than 150mm (6") should the principle hardware device fail.

11.2: SECUR ET™ - V6Y YOKE BRACKET

The V6Y is a discreet yoke style bracket, available in both black and white, and is used to mount the Tannoy V6 in both portrait and landscape orientations. The Tannoy V6 loudspeaker is fixed to the bracket using the M6 bolts and washers supplied in the accessory pack

Only the screws, fasteners, shakeproof and plain washers specified on figure 3. should be used to assemble the V6Y bracket.

The arms of the V6Y have long slots, through which M6 bolts are fitted, and screwed into the integral M6 inserts in the top and bottom of the Tannoy V6 cabinet.

The arms of the V6Y have long slots, through which M6 bolts are fitted, and screwed into the integral M6 inserts in the top and bottom of the Tannoy V6 cabinet.

These slots allow the installer to easily and precisely adjust the distance between the loudspeaker and the mounting surface for optimal discreet installation of the Tannoy V6.

Use the 20mm hole to pass the loudspeaker cable through before fixing the bracket to the wall.

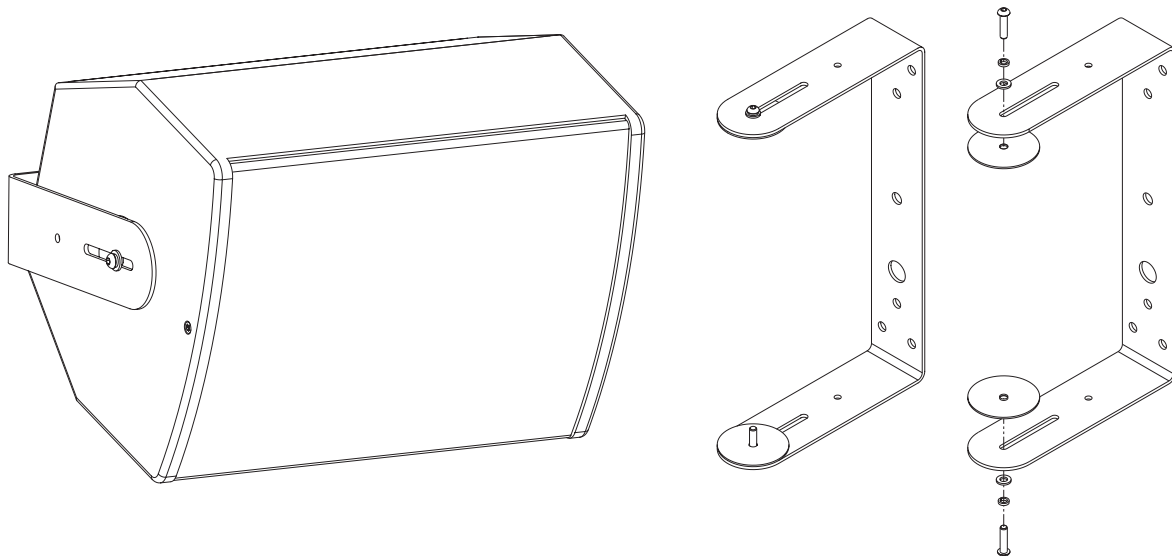

Use the table of parts along with the assembly drawing to assemble the V6Y.

ASSEMBLY VIEW	DESCRIPTION	QUANTITY
1	Yoke Bracket	1
2	Washer M6 Plain	2
3	Washer M6 Spring	2
4	M6 x 25 Button Head Screw	2
5	Rubber Friction Washer	2

VCB2: The VCB2 cluster bar is available in both black and white finishes and provides a platform onto which 2 x Tannoy V6 loudspeakers can be mounted using the V6Y yoke bracket (not supplied in the VCB2 kit). A number of different loudspeaker arrangements can be made depending on the application and the coverage pattern required (see figures 1 & 2).

Using the VCS ceiling saddle the resulting cluster can be attached to the ceiling.

VCB4: The VCB4 cluster bar (available in both black and white) provides the platform onto which 3-4 x Tannoy V6 loudspeakers can be mounted using the V6Y yoke bracket (not supplied in the VCB4 kit). A number of different loudspeaker arrangements can be made depending on the application and the coverage pattern required (see figures 3-6).

N.B. When using the VCB4 cluster bar system, one of the cluster bars is mounted above the other to produce a cross formation. To ensure an equal mounting height, the 2 x Tannoy V6 loudspeakers being flown from the lower cluster bar should be attached to the upper surface of this bar. While the 2 x Tannoy V6 loudspeakers being flown from the upper bar should be attached to the underside of this cluster bar.

Using the VCS ceiling saddle the resulting cluster can be attached to the ceiling.

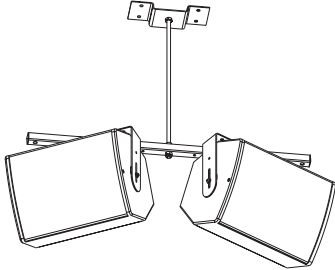

■ Fig. 1.

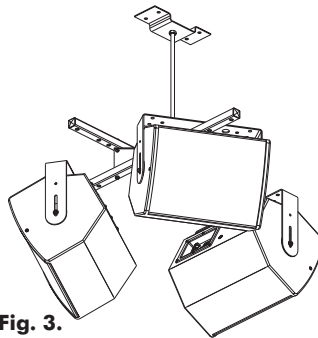

■ Fig. 3.

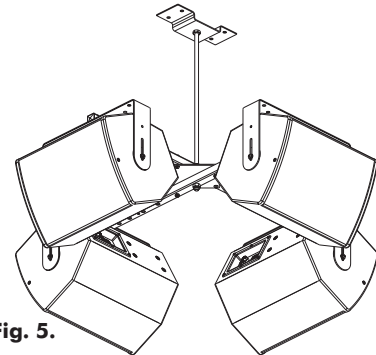

■ Fig. 5.

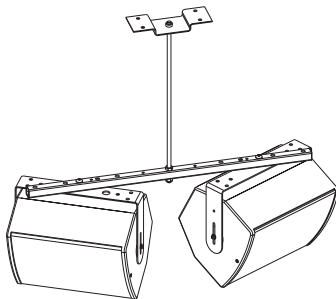

■ Fig. 2.

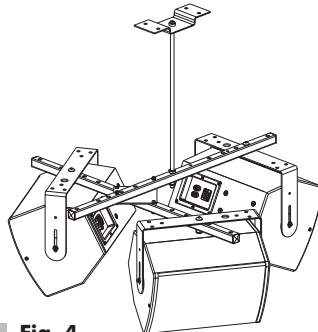

■ Fig. 4.

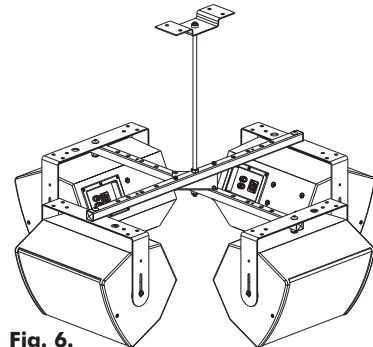

■ Fig. 6.

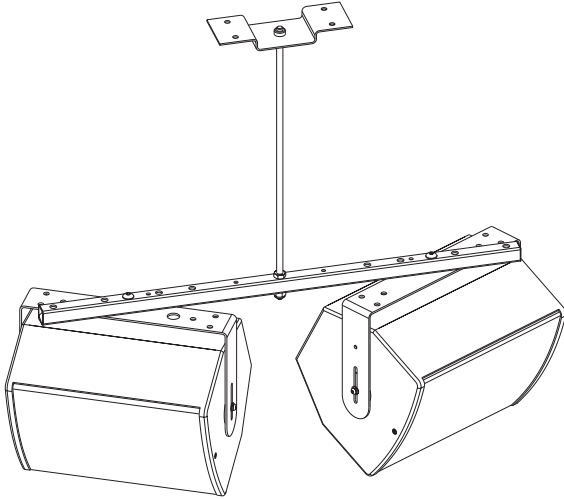

Contents of VCB2	DESCRIPTION	QUANTITY
1	Cluster Bar	1
2	Washer M10 Plain	2
3	Screw M10x40 Button Head	2
4	M10 Nyloc Nut	2
5	Blanking Plug	2

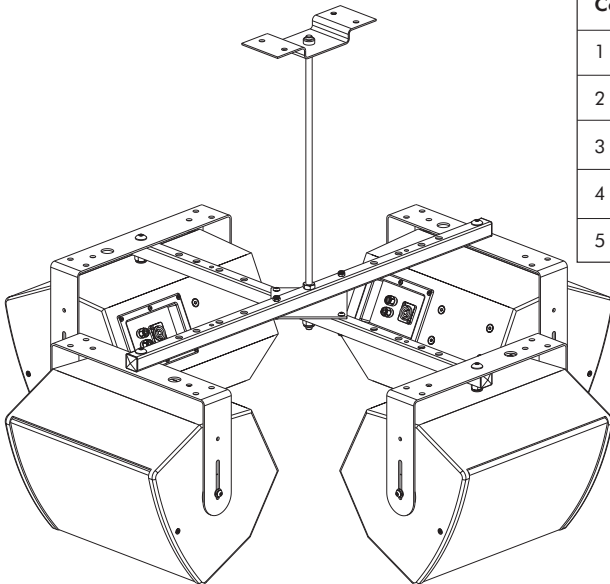

Contents of VCB4	DESCRIPTION	QUANTITY
1	Cluster Bar	1
2	Washer M10 Plain	2
3	Screw M10x40 Button Head	2
4	M10 Nyloc Nut	2
5	Blanking Plug	2

11.4: SECUR - ET™ VCS CEILING SADDLE

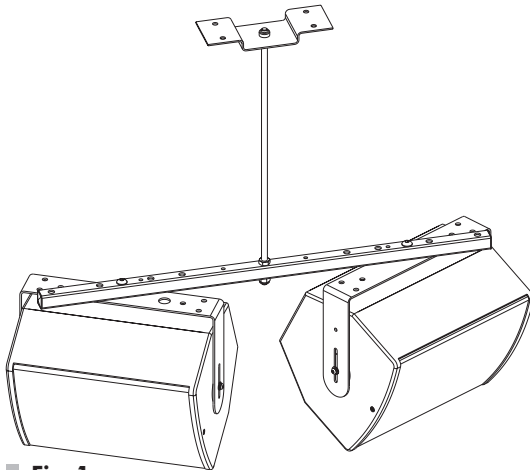

■ Fig. 1.

The VCS ceiling saddle available in both black and white finishes, and is to be used in conjunction with the V6Y, VCB2, VCB4 and a length of M10 threaded rod (not supplied by Tannoy Limited). The VCS ceiling saddle allows the Tannoy V6 loudspeaker to be suspended at a user defined distance from the ceiling as shown in Figure 1.

Included with the VCS is an M10 nut. This should be used to secure and lock the threaded rod in place at the top of the ceiling saddle.

11.5: SECUR - ET™ V8B WALL MOUNTING BRACKET

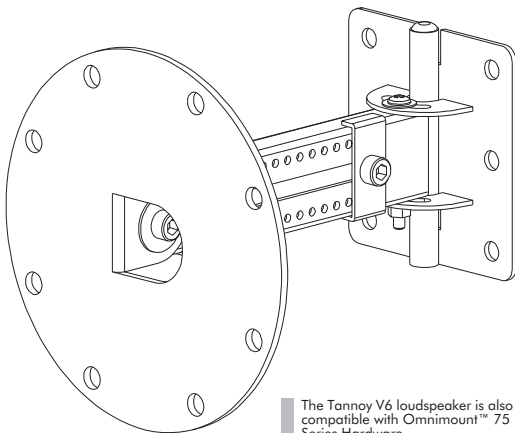

■ The Tannoy V6 loudspeaker is also compatible with Omnimount™ 75 Series Hardware

The V6 can be wall or ceiling mounted by using the V8B bracket which is designed to offer the maximum flexibility in selecting desired angles.

The V8B is supplied with M6 bolts for fixing to the loudspeaker, hinge clips which can be used to alter the angle of the wall fixing plate and an allen key to secure the arm length adjustment as well as the desired angle of 'tilt' of the loudspeaker .

The hinged wall mount plate enables the V8B to be fixed to flat walls and ceilings or to fit onto internal or external corners.

When the desired angle of tilt has been decided for the loudspeaker, the allen bolt holding the loudspeaker mounting plate onto the arm of the V8B can be tightened, the sprockets will hold the assembly firm ensuring it will not slip. The arm length can also be adjusted if desired. It is imperative that the bracket is fixed soundly to the wall. Be sure to use the correct fixings (e.g. Rawbolt, Rawplug) according to the wall type.

12.0: SYSTEM CONFIGURATIONS & OEM CONTROLLERS

With the vast array of digital loudspeaker management systems available it is inevitable that the user may opt to use a controller other than the TX1 & TDX2 as part of a large scale integrated system. The V6 has been designed to need no external equalisation to overcome system limitations. If the V6 is to be used alone with additional bass enhancement required and have the frequency response limits tighter than +/- 3dB as stated in section 10, then apply the parameters in the table below for optimised performance:

PARAMETER	UNIT/NAME	
Gain	(dB)	User definable
Delay	(ms)	User definable
Polarity		Positive
HPF	Freq (Hz)	49.6
	Slope (dB/oct)	24
	Filter Shape	Butterworth
LPF	Freq (Hz)	Thru
	Slope (dB/oct)	NA
	Filter Shape	NA
PEQ 1	Freq (Hz)	303
	Level (dB)	+1.0
	Type	Parametric
	Q / Bandwidth	2 / 0.5

PARAMETER	UNIT/NAME	
PEQ 2	Freq (Hz)	857
	Level (dB)	-0.8
	Type	Parametric
	Q / Bandwidth	2.5 / 0.4
PEQ 3	Freq (Hz)	1500
	Level (dB)	+1.5
	Type	Parametric
	Q / Bandwidth	1.7 / 0.6
PEQ 4	Freq (Hz)	8810
	Level (dB)	+2.5
	Type	Parametric
	Q / Bandwidth	1.9 / 0.53
PEQ 5	Freq (Hz)	
(not used)	Level (dB)	
	Type	
	Q / Bandwidth	

13.0: V6 SERVICE PARTS & ACCESSORIES

PART NUMBER	DESCRIPTION	PART NUMBER	DESCRIPTION
7900 0742	Driver Kit - 1728	8000 0740	Tannoy TX1 Active system controller/ 2-way crossover
7900 0683	HF Diaphragm Kit	8001 1930	Tannoy TDX2 Digital System Controller 90 - 250V UK
7300 0927	Crossover - 1456	8001 1940	Tannoy TDX2 Digital System Controller 90 - 250V EUR
8001 3310	V6Y - Secure ET- V6 Yoke Bracket (Black)	8001 1950	Tannoy TDX2 Digital System Controller 90 - 250V USA
8001 3311	V6Y - Secure ET- V6 Yoke Bracket (White)		
8001 2740	VCB2 - Secure ET - Cluster Bar (Black)		
8001 2750	VCB2 - Secure ET - Cluster Bar (White)		
8001 2760	VCB4 - Secure ET - Cluster Bar (Black)		
8001 2770	VCB4 - Secure ET - Cluster Bar (Black)		
8001 2830	VCS - Secur ET - Ceiling Saddle (Black)		
8001 2840	VCS - Secur ET - Ceiling Saddle (White)		

14.0: WARRANTY

NO MAINTENANCE OF THE V6 LOUDSPEAKERS IS NECESSARY.

All Tannoy professional loudspeaker products are covered by a 5 year warranty from the date of manufacture subject to the absence of misuse, overload or accidental damage. Claims will not be considered if the serial number has been altered or removed. Work under warranty should only be carried out by a Tannoy dealer or service agent. This warranty in no way affects your statutory rights. For further information please contact your dealer or distributor in your country. If you cannot locate your distributor please contact Customer Services, Tannoy Ltd at the address given below.

Customer Services, Tannoy Ltd., Rosehall Industrial Estate, Coatbridge, Strathclyde, ML5 4TF, Scotland

Telephone: 01236 420199 (National) +44 1236 420199 (International)

Fax: 01236 428230 (National) +44 1236 428230 (International)

E-Mail: prosales@tannoy.com

DO NOT SHIP ANY PRODUCT TO TANNOY WITHOUT PREVIOUS AUTHORISATION

Our policy commits us to incorporating improvements to our products through continuous research and development. Please confirm current specifications for critical applications with your supplier.

15.0: DECLARATION OF CONFORMITY



The following apparatus is/are manufactured in the United Kingdom by Tannoy Ltd of Rosehall Industrial estate, Coatbridge, Scotland, ML5 4TF and conform(s) to the protection requirements of the European Electromagnetic Compatibility Standards and Directives relevant to Domestic Electrical Equipment. The apparatus is designed and constructed such that electromagnetic disturbances generated do not exceed levels allowing radio and telecommunications equipment and other apparatus to operate as intended, and, the apparatus has an adequate level of intrinsic immunity to electromagnetic disturbance to enable operation as specified and intended.

Details of the Apparatus: Tannoy Contractor Loudspeaker

Model Number: V6

Associated Technical File: EMCV6

Applicable Standards: EN 50081-1 Emission

EN 50082-1 Immunity

Electrical Safety: EN 60065

Signed:

Position: Engineering Director - Tannoy Professional Products

Date: 10/06/2002

For Tannoy Ltd



Tannoy United Kingdom	T: +44 (0) 1236 420199	F: +44 (0) 1236 428230	E: enquiries@tannoy.com
Tannoy North America	T: (519) 745 1158	F: (519) 745 2364	E: inquiries@tannoyna.com

Tannoy adopts a policy of continuous improvement and product specification is subject to change.

tannoy.com