

Network Camera

User's Guide

Software Version 2.0

SNC-RZ30N/RZ30P

Owner's Record

The model and serial numbers are located at the bottom. Record these numbers in the spaces provided below. Refer to these numbers whenever you call upon your Sony dealer regarding this product.

Model No. _____

Serial No. _____

WARNING

To prevent fire or shock hazard, do not expose the unit to rain or moisture.

For AC Adaptor

To avoid electrical shock, do not open the cabinet. Refer servicing to qualified personnel only.

Important

Nameplate is located on the bottom.

For customers in the U.S.A. (SNC-RZ30N only)

This equipment has been tested and found to comply with the limits for a Class B digital device, pursuant to Part 15 of the FCC Rules. These limits are designed to provide reasonable protection against harmful interference in a residential installation. This equipment generates, uses, and can radiate radio frequency energy and, if not installed and used in accordance with the instructions, may cause harmful interference to radio communications. However, there is no guarantee that interference will not occur in a particular installation. If this equipment does cause harmful interference to radio or television reception, which can be determined by turning the equipment off and on, the user is encouraged to try to correct the interference by one or more of the following measures:

- Reorient or relocate the receiving antenna.
- Increase the separation between the equipment and receiver.
- Connect the equipment into an outlet on a circuit different from that to which the receiver is connected.
- Consult the dealer or an experienced radio/TV technician for help.

You are cautioned that any changes or modifications not expressly approved in this manual could void your authority to operate this equipment.

The shielded interface cable recommended in this manual must be used with this equipment in order to

comply with the limits for a digital device pursuant to Subpart B of Part 15 of FCC Rules.

If you have any questions about this product, you may call:

**Sony's Business Information Center (BIC) at
1-800-686-7669**

**or Write to: Sony Customer Information Services
Center**

**6900-29, Daniels Parkway, PMB 330
Fort Myers, Florida 33912**

Declaration of Conformity

Trade Name: SONY
Model No: SNC-RZ30N
Responsible Party: Sony Electronics Inc.
Address: 680 Kinderkamack Road, Oradell,
NJ 07649 USA
Telephone No: 201-930-6972

This device complies with part 15 of the FCC Rules. Operation is subject to the following two conditions:
(1) this device may not cause harmful interference, and
(2) this device must accept any interference received, including interference that may cause undesired operation.

Voor de klanten in Nederland

- Dit apparaat bevat een vast ingebouwde batterij die niet vervangen hoeft te worden tijdens de levensduur van het apparaat.
- Raadpleeg uw leverancier indien de batterij toch vervangen moet worden. De batterij mag alleen vervangen worden door vakbekwaam servicepersoneel.
- Gooi de batterij niet weg maar lever deze in als klein chemisch afval (KCA).
- Lever het apparaat aan het einde van de levensduur in voor recycling, de batterij zal dan op correcte wijze verwerkt worden.



NOTICE TO USERS

© 2002, 2003 Sony Corporation. All rights reserved.
This manual or the software described herein, in whole or in part, may not be reproduced, translated or reduced to any machine readable form without prior written approval from Sony Corporation.

SONY CORPORATION PROVIDES NO WARRANTY WITH REGARD TO THIS MANUAL, THE SOFTWARE OR OTHER INFORMATION CONTAINED HEREIN AND HEREBY EXPRESSLY DISCLAIMS ANY IMPLIED WARRANTIES OF MERCHANTABILITY OR FITNESS FOR ANY PARTICULAR PURPOSE WITH REGARD TO THIS MANUAL, THE SOFTWARE OR SUCH OTHER INFORMATION. IN NO EVENT SHALL SONY CORPORATION BE LIABLE FOR ANY INCIDENTAL, CONSEQUENTIAL OR SPECIAL DAMAGES, WHETHER BASED ON TORT, CONTRACT, OR OTHERWISE, ARISING OUT OF OR IN CONNECTION WITH THIS MANUAL, THE SOFTWARE OR OTHER INFORMATION CONTAINED HEREIN OR THE USE THEREOF.

Sony Corporation reserves the right to make any modification to this manual or the information contained herein at any time without notice.
The software described herein may also be governed by the terms of a separate user license agreement.

“Memory Stick” is a trademark of Sony Corporation.
Microsoft, Windows, Internet Explorer and MS-DOS are registered trademarks of Microsoft Corporation in the United States and/or other countries.
Netscape and Navigator are registered trademarks of Netscape Communications Corporation in the U.S. and other countries.
Java is a trademark of Sun Microsystems, Inc. in the United States and other countries.
MMX and Pentium are registered trademarks of Intel Corporation or its subsidiaries in the United States and other countries.
Jeode is a registered trademark or trademark of Insignia Solutions, Inc. in the United States and other countries.

All other company and product names are trademarks or registered trademarks of the respective companies or their respective makers.

Table of Contents

Overview

How to Use This User's Guide	6
Precautions	6
Operating Precautions	6

Operating the Camera

Logging in to Homepage — Welcome Page	7
Logging in as a User	7
Logging in as Administrator	7
About Viewers	8
Configuration of Main Viewer Page	9
Menu Section	9
Image Control Section	10
Monitor Image Section	10
Zoom Bar	10
Controlling the Monitor Image	11
Operating the Camera from the Image Control Section	11
Panning and Tilting	11
Zooming	12
Focusing	12
Moving the Camera to the Preset Position	13
Operating the Camera from the Monitor Image	13
Panning and Tilting by Clicking the Monitor Image	13
Panning, Tilting and Zooming by Specifying the Area	13
Zooming Using the Center Wheel of the Mouse	14
Zooming Using the Zoom Bar	14
Controlling the Application Manually	14
Sending a Still Image File to an FTP Server	14
Sending a Still Image via E-mail	14
Recording a Still Image on an ATA Memory Card or the Built-in Memory of the Camera	15
Controlling Alarm Output	15
Selecting the Day/Night Mode	15
Capturing a Monitor Image	15

Operating the Camera Using a Pocket PC

Logging in to Homepage — Welcome Page	16
Configuration of Main Viewer Page	17
Monitor Image Section	17
Image Control Section	17

Administrating the Camera

Configuration of Administrator Menu Page	18
Configuring the System — System setting Page	19
System setting Section	19
Date time setting Section	21
Initialization Section	21
Setting the Camera — Camera setting Page	22
Camera setting Section	22
Day/Night setting Section	25
Camera control mode setting Section	25
Configuring the Network — Network setting Page	26
Wired LAN setting Section	26
Wireless LAN setting Section	26
HTTP port setting Section	28
Notifying the IP Address — Dynamic IP address notification Section	28
Setting the User — User setting Page	29
Setting the Security — Security setting Page	30
Activating/Deactivating the Security Function — Security usage setting Page	30
Setting the Security Function —Securing setting Page	30
Setting the Camera Position and Action — Preset position setting Page	31
Storing the Pan, Tilt and Zoom Positions — Position preset Section	31
Moving the Camera to the Preset Position by the Alarm — Position at alarm Section	32
Checking the Preset Position Settings — Preset position table Section	32
Programming the Tour — Tour setting Section	32
Checking the Tour Settings — Tour table Section	33
Activating the Tour— Tour selection Section	33
Sending Images to FTP Server — FTP client setting Page	34
Activating/Deactivating the FTP Client Function — FTP client usage setting Page	34
Setting the FTP Client Function — FTP client setting Page	34
Alarm mode setting Section	35
Periodical sending mode setting Section	35
Operating the Digest Viewer	36
Downloading Images from the Camera — FTP server setting Page	37
Activating/Deactivating the FTP Server Function — FTP server usage setting Page	37
Setting the FTP Server Function — FTP server setting Page	37
Sending an Image via E-mail — SMTP setting Page	38

Activating/Deactivating the SMTP Function	
— SMTP usage setting Page	38
Setting the SMTP Function — SMTP setting	
Page	38
Alarm mode setting Section	39
Periodical sending mode setting Section	39
Setting the Alarm Out 1 or 2 — Alarm out 1 or 2	
setting Page	40
Activating/Deactivating the Alarm Out 1 Function	
— Alarm out 1 usage setting Page	40
Setting the Alarm Out 1 Function — Alarm out 1	
setting Page	40
Alarm mode setting Section	40
Timer mode setting Section	41
Recording Images in Memory — Image memory	
setting Page	41
Activating/Deactivating the Image Memory	
Function — Image memory usage setting	
Page	41
Recording an Image in the Selected Memory —	
Image memory setting Page	42
Alarm mode setting Section	43
Periodical recording mode setting Section	43
Directory Structure of Image Memory	44
Setting the Alarm Buffer — Alarm buffer	
setting Page	45
Communicating Data via Serial Port — Serial	
setting Page	45
Setting the Schedule — Schedule setting Page ..	46
Setting the Activity Detection Function — Activity	
detection setting Page	47
Setting the Activity Detection Area	47
Showing the Pop-up — Pop-up setting Page	48

Others

Using the Supplied Setup Program	49
Assigning the IP Address Using the Setup	
Program	49
Changing the Communication Bandwidth	50
Setting the Date and Time	50
Rebooting the Camera	51
Assigning the IP Address to the Camera Using	
ARP Commands	51
Using the SNMP	52
1. Inquiry Commands	52
2. Setting Commands	52

How to Use This User's Guide

This User's Guide explains how to operate the SNC-RZ30N/RZ30P Network Camera from a computer. The User's Guide is written to be read on the computer display.

As this section gives tips on using the User's Guide, read it before you operate the camera.

Jumping to the related page

When you read the User's Guide on the computer display, click on the sentence to jump to the related page.

Software display examples

Note that the displays shown in the User's Guide are explanatory examples. Some displays may be different from the ones which appear as you operate the application software.

Printing the User's Guide

Depending on your system, certain displays or illustrations in the User's Guide, when printed out, may differ from those as portrayed on your screen.

Installation Manual (printed matter)

The supplied Installation Manual describes the names and functions of parts and controls of the Network Camera, connecting examples and how to set up the camera. Be sure to read the Installation Manual before operating.

Precautions

This Sony product has been designed with safety in mind. However, if not used properly electrical products can cause fires which may lead to serious body injury. To avoid such accidents, be sure to heed the following.

Heed the safety precautions

Be sure to follow the general safety precautions and the "Operating Precautions."

In case of a breakdown

In case of system breakdown, discontinue use and contact your authorized Sony dealer.

In case of abnormal operation

- If the unit emits smoke or an unusual smell,
- If water or other foreign objects enter the cabinet, or
- If you drop the unit or damage the cabinet:

- 1 Disconnect the camera cable and the connecting cables.
- 2 Contact your authorized Sony dealer or the store where you purchased the product.

Operating Precautions

Operating or storage location

Avoid operating or storing the camera in the following locations:

- Extremely hot or cold places (Operating temperature: 0°C to +40°C [32°F to 104°F])
- Exposed to direct sunlight for a long time, or close to heating equipment (e.g., near heaters)
- Close to sources of strong magnetism
- Close to sources of powerful electromagnetic radiation, such as radios or TV transmitters

Transportation

When transporting the camera, repack it as originally packed at the factory or in materials of equal quality.

Cleaning

- Use a blower to remove dust from the lens or optical filter.
- Use a soft, dry cloth to clean the external surfaces of the camera. Stubborn stains can be removed using a soft cloth dampened with a small quantity of detergent solution, then wipe dry.
- Do not use volatile solvents such as alcohol, benzene or thinners as they may damage the surface finishes.

Operating the Camera

The Operating the Camera section explains how to monitor the image from the camera using the Web browser. For setting the camera, see “Administrating the Camera” on page 18.

Logging in to Homepage — Welcome Page

Logging in as a User

- 1 Start the web browser on the computer and type the IP address of the camera you want to monitor.

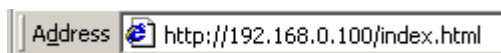

The welcome page of **Network Camera SNC-RZ30** is displayed.

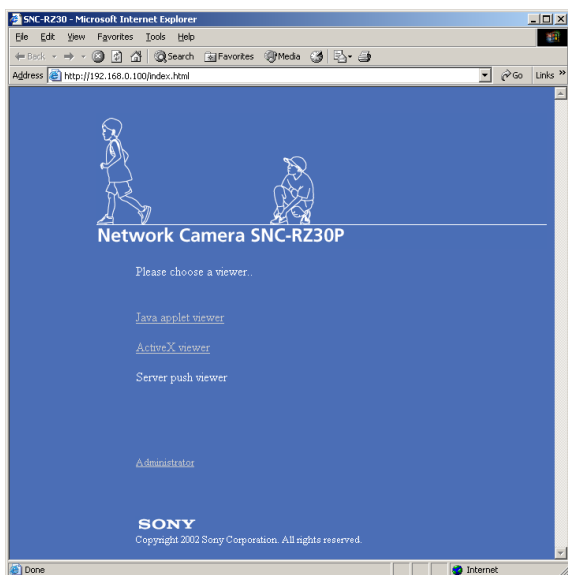

- 2 Click to select the viewer.
You can select the viewer from among **Java applet viewer**, **ActiveX viewer** and **Server push viewer**, whichever is suitable for your system environments and usage.
For details, see “About Viewers” on page 8.
When you have selected the viewer, the main viewer page appears (see page 9).

Note

To operate the welcome page correctly, set the security level of the Internet Explorer to **Medium** or lower, as follows:

- 1 Select **Tool** from the menu bar of Internet Explorer, then select **Internet Options** and **Security** tab in sequence.
- 2 Click the **Internet** icon (when using the camera via the Internet) or **Local intranet** icon (when using the camera via a local network).
- 3 Set the slider to **Medium** or lower. (If the slider is not displayed, click **Default Level**.)

When using antivirus software in the computer

- When you use antivirus software in your computer, the camera performance may be reduced, for example, the frame rate for displaying the image may lower.
- The Web page displayed when you log in the camera uses Java Script. The display of the page may be affected if you use antivirus software in your computer.

Logging in as Administrator

If you log in the camera as the Administrator, you can perform all the settings provided with the software. The Administrator may be logged in at any time, regardless of the number of the users being accessed.

- 1 Click **Administrator** on the welcome page.
The login page appears.

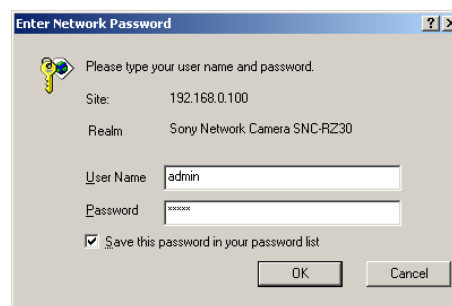

- 2 Enter the user name and password for Administrator, then click **OK**.
The user name “admin” and the password “admin” are set at the factory for the Administrator. You can change them on the User setting page in the Administrator menu (see page 29).

The welcome page is changed to that for Administrator.

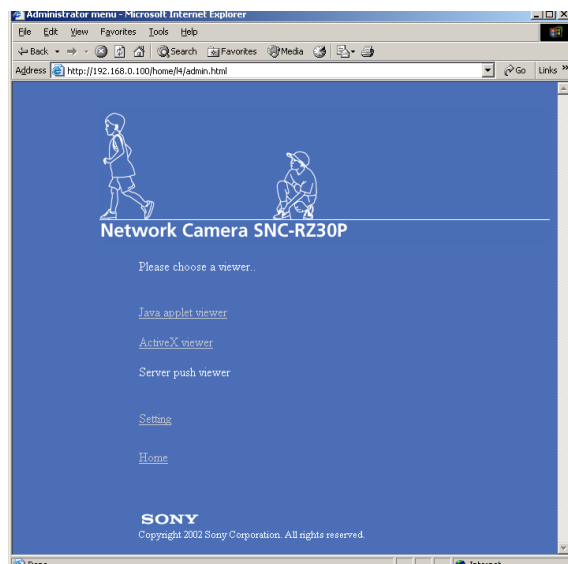

- 3** Select the viewer.
You can select the viewer from among **Java applet viewer**, **ActiveX viewer** and **Server push viewer**, whichever is suitable for your system environments and usage.
For details, see “About Viewers” on page 8.
When you have selected the viewer, the main viewer page appears (see page 9).

Other functions on the welcome page for Administrator

Setting

Click to display the Administrator menu (see page 18).

Home

Click to return to the normal welcome page.

About Viewers

You can select one of the following three viewers.

Java applet viewer

The Java applet viewer operates on Internet Explorer or Netscape.

It displays the main viewer page using Java.

With this viewer, you can use all the functions provided with this software.

Notes

- The frame rate is lower than that for the other viewers.
- If the viewer does not operate correctly, install or activate Java as follows:

If you are using Internet Explorer

Select **Tool** from the menu bar of Internet Explorer, then select **Internet Option** and the **Advanced** tab in sequence, and check **JIT compiler for virtual machine enabled (requires restart)**. Then restart Internet Explorer.

If you are going to install Netscape

Install Java in the process of Netscape installation, following the instructions of the installer.

After installing, select **Edit** from the menu bar of Netscape, then **Setting** and **Details** for category in sequence, and check **Activate Java**.

If you are using Netscape without Java installed

Install Java from the **Plug-in Download Page** of Netscape.

If you are using Netscape with Java installed, but the viewer does not operate correctly

Make sure that the version of your Java Plug-in is one of those shown below. If your Java Plug-in is of a different version, uninstall it, then install the correct version.

Java Plug-in: Ver.1.3.1_02, Ver.1.3.1_03, Ver.1.4.0, Ver.1.4.0_01

To confirm the Java Plug-in version

Click the **Start** button of Windows, then select **Settings** and **Control Panel** in sequence to display the Java Plug-in version.

To install Java Plug-in

Download **Java 2 Runtime Environment, Standard Edition (JRE)** from Netscape Netcenter or Sun HomePage, and install it following the instructions of the installer. After installing, select **Edit** from the menu bar of Netscape, then **Setting** and **Details** for category in sequence, and check **Activate Java**.

ActiveX viewer

The ActiveX viewer operates on Internet Explorer.

It displays the main viewer page using ActiveX.

With this viewer, you can display images at a high frame rate and use all the functions provided with this software.

When you log in the camera using Internet Explorer for the first time, the Security Warning appears. Click **Yes** and install ActiveX Control.

Notes

- If you cannot display the image on Windows NT4.0 or Windows 98, install **MFC42DLL Version Up Tool** stored in the supplied CD-ROM.
- If **Automatic configuration** is enabled in the Local Area Network (LAN) Settings on Internet Explorer, the image may not be displayed. In this case, disable

Automatic configuration and set the Proxy server manually. For setting the Proxy server, consult your network administrator.

- When you install ActiveX viewer on Windows NT4.0, Windows 2000 or Windows XP, you should have logged in the computer as the Administrator.

Server push viewer

The Server push viewer operates on Netscape. When you select this viewer, the main viewer page is displayed through the Server push technology which the Netscape supports as standard.

Notes

- When you use the Server push viewer, the time display, pop-up display and image size selection do not operate. As the image rotation does not operate, the camera image is always upside down when the camera is installed on a desk top.
- If you display a large size image such as VGA with a high frame rate using the Server push viewer, the computer may freeze. Change **Frame rate** on the main viewer page (see page 11), or **Image size** on the Camera setting page (see page 22) to match your computer performance.
- If you use the Server push viewer, the image display may freeze. To resolve this problem, click **Refresh** of the browser.

Tip

Every page of this software is optimized as display character size **Medium** for Internet Explorer, or **100%** for Netscape.

Configuration of Main Viewer Page

When you select the viewer, the main viewer page is displayed.

This section briefly explains the functions of the parts and controls on the main viewer page. For a detailed explanation on each part or control, see the specified pages.

Main viewer page

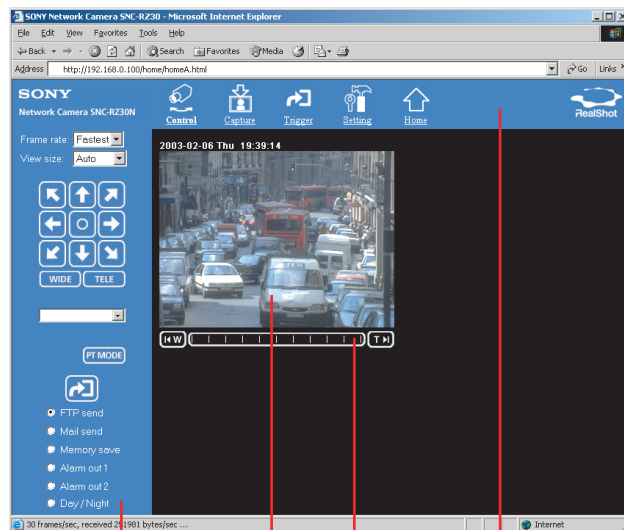

Image control section zoom bar Monitor image section Menu section

Menu Section

The available functions are limited by user access right. You can change user access right on the User setting page (see page 29).



Control

Displays the camera control parts on the image control section. (See “Operating the Camera from the Image Control Section” on page 11.)

Also enables the panning, tilting and zooming operations from the monitor image. (See “Operating the Camera from the Monitor Image” on page 13.) User access right **Level 2** to **Level 4** is required for this function.



Capture

Captures a still image shot by the camera and stores it in the computer. (See “Capturing a Monitor Image” on page 15.)



Trigger

Displays the trigger control parts on the image control section.

By clicking the trigger button, you can control various applications manually. (See “Controlling the Application Manually” on page 14.)

User access right **Level 3** or **Level 4** is required for this function.



Setting

Displays the Administrator menu. (See “Configuration of Administrator Menu Page” on page 18.)

User access right **Level 4** is required for this function.



Home

Displays the Welcome page.

Image Control Section

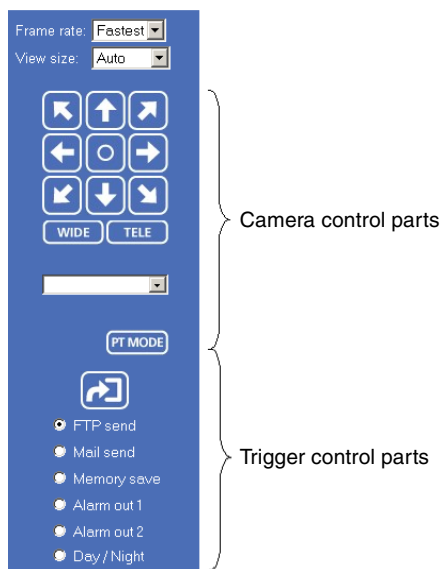

Frame rate

Selects the frame rate to transmit images.
See “Selecting the frame rate” on page 11.

View size

Selects the image size to be displayed.
See “Selecting the view size” on page 11.

Camera control parts

These parts are displayed when you click **Control** on the menu section. You can operate the camera using these parts.

See “Operating the Camera from the Image Control Section” on page 11.

Trigger control parts

These parts are displayed when you click **Trigger** on the menu section. You can output a trigger using these parts.
See “Controlling the Application Manually” on page 14.

Monitor Image Section



The image shot by the camera is shown here.
Click **Control** on the menu section to allow panning, tilting and zooming of the camera from the monitor image.

See “Operating the Camera from the Monitor Image” on page 13.

Zoom Bar



The zoom bar is displayed when you click **Control** on the menu section. You can operate the optical zoom using the zoom bar.

See “Zooming Using the Zoom Bar” on page 14.

Controlling the Monitor Image

You can control the monitor image from the image control section on the main viewer page.

Image control section

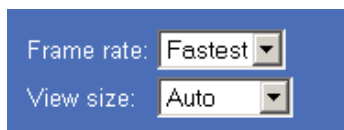

Selecting the frame rate

Click the down-arrow button in the **Frame rate** box and select the frame rate with which the images are transmitted, from the drop-down list.

You can select the frame rate from among the following:
SNC-RZ30N:

1, 2, 3, 4, 5, 6, 8, 10, 15, 20, 25, Fastest

SNC-RZ30P:

1, 2, 3, 4, 5, 6, 8, 12, 16, 20, Fastest

The numbers indicate “FPS” (the number of frames transmitted per second).

With **Fastest**, the camera transmits the maximum number of frames possible for the connected line. The maximum frame rate is 30 FPS for the SNC-RZ30N and 25 FPS for the SNC-RZ30P.

Note

The frame rate options indicate the maximum number of frames that can be transmitted. The number of frames actually transmitted may vary depending on the network environments and camera settings (image size and image quality settings).

Selecting the view size

Click the down-arrow button in the **View size** box and select the view size from the drop-down list.

You can select the view size from among the following:

Auto, 640 × 480, 320 × 240, 160 × 120

Auto is determined by the image size specified with **Image size** on the Camera setting page (see page 22).

Operating the Camera from the Image Control Section

You can operate the camera from the image control section on the main viewer page.

For this function, user access right **Level 2** to **Level 4** is required (see page 29).

Click  **Control** on the menu section to display the camera control parts.

Image control section (camera control parts)



Panning and Tilting

You can pan and tilt the camera using the 8-direction arrow buttons or the tablet.

Setting the pan/tilt mode

Click . Each click alternates the 8-direction arrow mode and the tablet mode.

Panning and tilting using the 8-direction arrow buttons

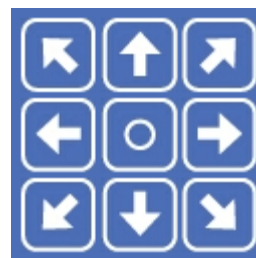

Observe the monitor image and click the arrow button indicating the direction in which you want to move the camera. The camera moves and the monitor image follows.

Hold down the arrow button to move the direction of the camera continuously.

Click  to return the camera to the factory-preset default position.

Notes

- If the Exclusive control mode menu on the System setting page is set to **On** (see page 20), the remaining operation time is displayed instead of .
- You can change the operation mode of the panning and tilting using the 8-direction arrow buttons from the Camera control mode setting section on the Camera setting page (see page 25). When you have changed the operation mode, click **Control** on the menu section to update the operation mode setting on the image control section.

Panning and tilting using the tablet

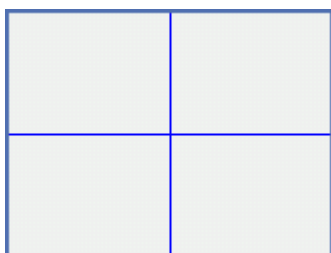

When you click **PT MODE**, the 8-direction arrow buttons change to a tablet. The tablet represents the monitor image.

A click on the tablet moves the direction of the camera so that the clicked position goes to the center of the monitor image.

If you want to change the direction of the camera further, click on the tablet and drag in the direction in which you want to move the camera. The direction of the camera moves as you drag. Hold down the button to move the direction of the camera continuously.

Notes

- The tablet represents the whole monitor image even when you have trimmed the monitor image using the Area setting menu on the Camera setting page (see page 23).
- If the Exclusive control mode menu on the System setting page is set to **On** (see page 20), the remaining operation time is displayed on the lower right corner of the tablet.

Zooming

TELE

Click to zoom in.

WIDE

Click to zoom out.

Note

You can change the operation mode of the zooming using the TELE/WIDE buttons from the Camera control mode setting section on the Camera setting page (see page 25). When you have changed the operation mode, click **Control** on the menu section to update the operation mode setting on the image control section.

DZOOM X2

When the Zoom mode menu on the Camera setting page is set to **Optical only**, clicking this button operates the electronic $\times 2$ zoom.

The button name changes to **DZOOM x 1**.

DZOOM X1

When the Zoom mode menu on the Camera setting page is set to **Optical only**, this button is displayed while the electronic $\times 2$ zoom is operating. Clicking this button cancels the electronic $\times 2$ zoom.

The button name changes to **DZOOM x 2**.

About the zoom range

When the Zoom mode menu on the Camera setting page is set to **Full** (see page 23), you can operate high-magnification zoom, optical zoom of $\times 25$ and electronic zoom of $\times 12$, giving $\times 300$ in total. The electronic zoom will operate after the optical zoom.

When the Zoom mode menu is set to **Optical only**, only optical zoom of $\times 25$ can operate. In this case, you can use an electronic zoom of $\times 2$ by clicking the **DZOOM x 2** button. To cancel the electronic zoom, click **DZOOM x 1**.

Note

When you have changed the Zoom mode menu on the Camera setting page, click the Control button on the menu section to update the zoom mode setting on the image control section.

Focusing

The focus is automatically adjusted when the Focus mode menu on the Camera setting page is set to **Auto** (see page 23). When you set it to **Manual**, you can adjust the focus manually from the image control section, or adjust it with a push of the button.



Adjust the focus manually by clicking the two buttons alternately.



Click this button to adjust the focus instantly.

Notes

- When you have changed the Focus mode menu on the Camera setting page, click the Control button on the menu section to update the focus mode setting on the image control section.
- You can change the operation mode of the manual focusing using the NEAR/FAR buttons from the Camera control mode setting section on the Camera setting page (see page 25). When you have changed the operation mode, click **Control** on the menu section to update the operation mode setting on the image control section.
- If the NEAR, FAR and ONE PUSH AF buttons are not displayed, click the FOCUS button on the image control section. The three buttons appear and the FOCUS button name changes to **PRESET**.

Moving the Camera to the Preset Position



When you click this button, the PRESET list box appears.

The PRESET button name changes to **FOCUS**.

PRESET list box

Click the down-arrow button and select the preset position name from the drop-down list. Then, the camera will move to the preset position that you have stored in memory using the Preset position setting page (see page 31).

Operating the Camera from the Monitor Image

You can operate panning, tilting and zooming of the camera by clicking the mouse on the monitor image. Zooming is also operative using the zoom bar under the monitor image.

For this function, user access right **Level 2** to **Level 4** is required (see page 29).

To enable this function, click **Control** on the menu section.

Note

You cannot operate panning, tilting and zooming from the monitor image when you use the Server push viewer.

Panning and Tilting by Clicking the Monitor Image

Click on the monitor image, and the camera moves so that the clicked portion goes to the center of the display.

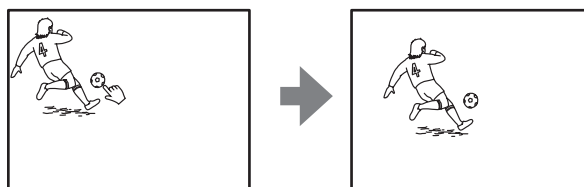

Panning, Tilting and Zooming by Specifying the Area

Click and hold the left button of the mouse on the monitor image, and drag the mouse diagonally to draw a red frame around the portion you want to enlarge. The camera moves so that framed portion goes to the center of the display and is zoomed in.

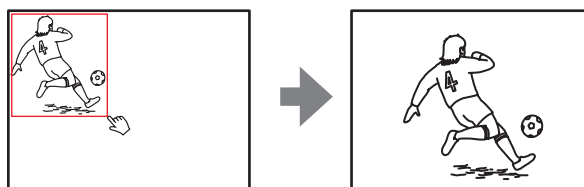

Notes

- When the Zoom mode menu on the Camera setting page is set to **Full** (see page 23), zooming of the specified area stops at the TELE end of the optical zoom. If you want to zoom in further using the electronic zoom, specify the area again.

- When the specified area is zoomed in, the center may be shifted. In this case, click the point you want to move to the center.

Zooming Using the Center Wheel of the Mouse

When you use the ActiveX viewer, you can zoom in/out using the center wheel of the mouse. Turn the center wheel forward to zoom in, and backward (toward you) to zoom out.

Notes

- This function does not operate when you use a mouse without the center wheel.
- This function does not operate on the Java applet viewer or the Server push viewer.
- This function may not operate correctly depending on your system environments.

Zooming Using the Zoom Bar

You can operate the optical zoom (×1 to ×25) using the zoom bar displayed under the monitor image.



Click **T** to zoom in to the TELE end (×25).
 Click **W** to zoom out to the WIDE end (×1).
 Click on the zoom bar, and the image is zoomed in or out according to the clicked position.

Notes

- This function does not operate on the Server push viewer.
- The zoom bar only allows optical zoom (×1 to ×25) even if the Zoom mode on the Camera setting page is set to **Full**.

Controlling the Application Manually

You can send an image or output a trigger to control the alarm output, using the image control section on the main viewer page.

For this function, user access right **Level 3** or **Level 4** is required (see page 29).



Click  **Trigger** on the menu section to display the trigger control parts.

Image control section (trigger control parts)

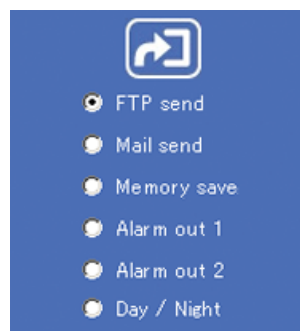

Sending a Still Image File to an FTP Server

If you select **FTP send** and click , the current still image is captured and the captured image file is sent to the FTP server specified on the FTP client setting page. To use this function, you need to select the **Use FTP client function** option and the **Manual** mode on the FTP client setting page.

For details, see “Sending Images to FTP Server — FTP client setting Page” on page 34.

Note

If the camera is installed on a desk top, the sent still image is upside down.

Sending a Still Image via E-mail

If you select **Mail send** and click , the current still image is captured and an E-mail with the captured image file attached is sent to the E-mail address(es) specified on the SMTP setting page.

To use this function, you need to select the **Use SMTP function** option and the **Manual** mode on the SMTP setting page.

For details, see “Sending an Image via E-mail — SMTP setting Page” on page 38.

Note

If the camera is installed on a desk top, the sent still image is upside down.

Recording a Still Image on an ATA Memory Card or the Built-in Memory of the Camera

If you select **Memory save** and click , the current still image is captured and stored in the memory specified on the Image memory setting page.

To use this function, you need to select the **Use image memory function** option and the **Manual** mode on the Image memory setting page.

For details, see “Recording Images in Memory — Image memory setting Page” on page 41.

Note

If the camera is installed on a desk top, the recorded still image is upside down.

Controlling Alarm Output

If you select **Alarm out 1** or **Alarm out 2** and click , you can control alarm out 1 or alarm out 2 of the I/O port on the camera manually. Each click switches the relay between short-circuit and open alternately.

To use this function, you need to select the **Use alarm out 1 (or 2) function** option and the **Manual** mode on the Alarm out 1 or Alarm out 2 setting page.

For details, see “Setting the Alarm Out 1 or 2 — Alarm out 1 or 2 setting Page” on page 40.

For the connection of peripheral devices to the Alarm out of the I/O port, see the supplied Installation Manual.

Selecting the Day/Night Mode

If you select **Day/Night** and click , you can select the Day/Night mode. Each click switches between the day mode and night mode.

To use this function, you need to select the Day/Night mode menu on the Camera setting page to **Manual**.

For details, see “Setting the Camera — Camera setting Page” on page 25.

Capturing a Monitor Image

If you click the  **Capture** button on the menu section, the current still image is captured and displayed on the monitor image section.

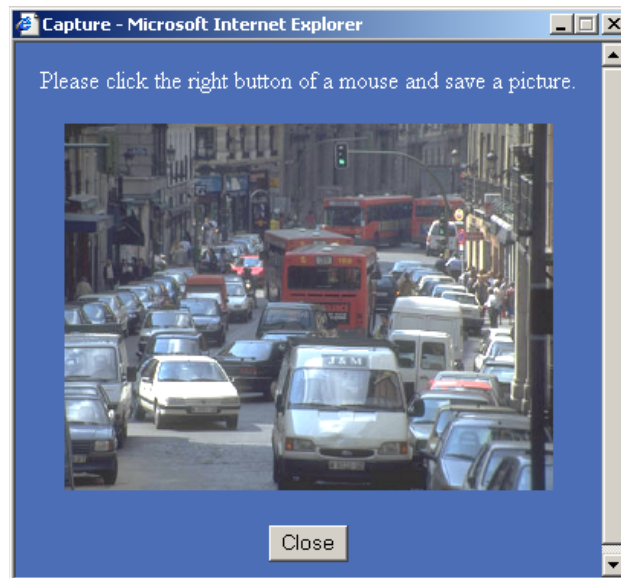

Note

If the camera is installed on a desk top, the captured still image is upside down.

To save the captured image

Right-click on the monitor image and select **Save As** from the menu. Then, the Save Picture dialog appears. Type the file name and specify the destination to which the image file is to be stored, and click **Save**. The image is saved in the JPEG format.

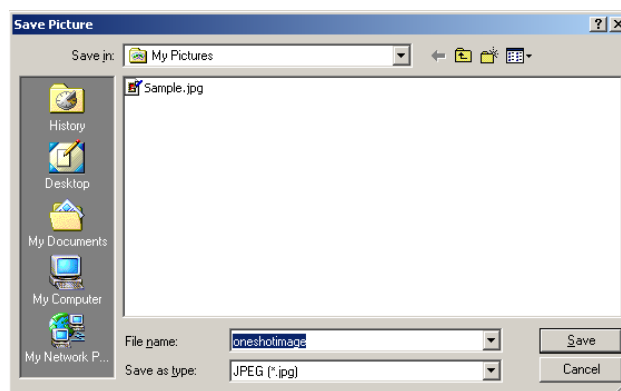

Operating the Camera Using a Pocket PC

You can display images and operate the camera using a PDA (Personal Digital Assistant) that runs on Microsoft Pocket PC 2002.

System requirements

OS: Microsoft Pocket PC 2002

Web browser: Microsoft Internet Explorer

CPU: Strong ARM 206 MHz or higher

RAM: 64 MB or more

Plug-in: Jeode Ver.1.9.1 (Java available)

Note

Jeode is required to display an image from the camera and operate the camera. If Jeode is not installed, install it following the manual supplied with the Pocket PC.

Logging in to Homepage — Welcome Page

- 1 Start the web browser on the Pocket PC and type the IP address of the camera you want to monitor.

The welcome page of Network Camera SNC-RZ30 is displayed.

- 2 Tap to select the viewer.



Select **Viewer1** to monitor the image only.
Select **Viewer2** to monitor the image and operate the camera.

When you have selected the viewer, the main viewer page appears.

Notes

- If the page is not displayed correctly, tap the Refresh button on the web browser.
- When you use antivirus software in your Pocket PC, the camera performance may be reduced, for example, the frame rate for displaying the image may lower.
- The Web page displayed when you log in the camera uses Java Script. The display of the page may be affected if you use antivirus software in your Pocket PC.

Configuration of Main Viewer Page

When you select the viewer, the main viewer page is displayed.

This section briefly explains the functions of the parts and controls on the main viewer page. For a detailed explanation on each part or control, see the specified pages.

Main viewer page

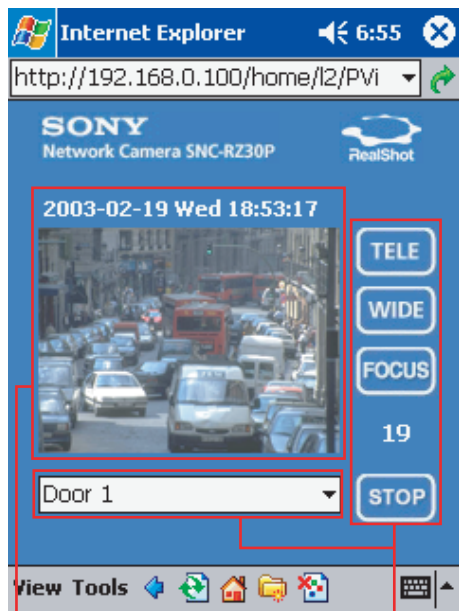

Monitor image section

Image control section

Monitor Image Section

The view size is fixed to **160 × 120** regardless of the Image size setting on the Camera setting page (see page 22).

Improving the frame rate

If you set the Image size menu on the Camera setting page to **160 × 120**, a higher frame rate is obtained with the Pocket PC.

Panning and Tilting

When you have selected **Viewer2**, tap the stylus on the monitor image to pan/tilt the camera.

The direction of the camera moves so that the tapped portion goes to the center of the display.

Image Control Section



Tap to start the viewer operation.

The name of the button changes to **Stop**.



Tap to stop the viewer operation.

The image refreshment stops and panning, tilting and zooming are not operative.

The name of the button changes to **Start**.

The following buttons are displayed only when you have selected **Viewer2**.



Tap to acquire the right to operate the camera for panning and tilting. The waiting time or the remaining operation time is displayed in seconds.

This button is displayed only when the Exclusive control mode menu on the System setting page is set to **On** (see page 20).



Tap to zoom in.



Tap to zoom out.



Tap to adjust the focus instantly.

This button is displayed only when the Focus mode menu on the Camera setting page is set to **Manual** (see page 23).

Note

When you have changed the Focus mode menu on the Camera setting page, click **Refresh** on the web browser to update the focus mode setting on the image control section.

PRESET list box



Tap the down-arrow button and select the preset position name from the drop-down list. Then, the camera will move to the preset position that you have stored in memory on the Preset position setting page (see page 31).

Administrating the Camera

The Administrating the Camera section explains how to set the functions of the camera by the Administrator. For monitoring the camera image, see “Operating the Camera” on page 7.

Configuration of Administrator Menu Page

The Administrator menu page is displayed when the Administrator having **Level 4** access right selects **Setting** on the welcome page for Administrator, or when the  **Setting** button on the menu section of the main viewer page is clicked.

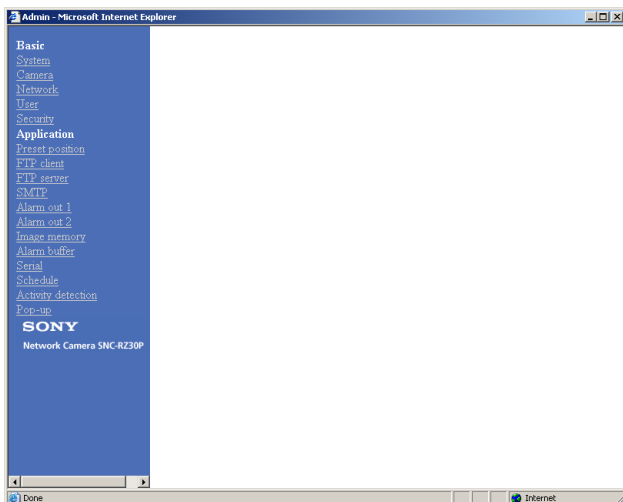

The Administrator menu consists of the Basic menu and the Application menu. The Basic menu is used for basic settings of the camera, and the Application menu is used for setting various applications according to individual. Click on each menu name to display its setting page.

Basic menu

System

Displays the System setting page.
See “Configuring the System — System setting Page” on page 19.

Camera

Displays the Camera setting page.
See “Setting the Camera — Camera setting Page” on page 22.

Network

Displays the Network (Ethernet) setting page.
See “Configuring the Network — Network setting Page” on page 26.

User

Displays the User setting page.
See “Setting the User — User setting Page” on page 29.

Security

Displays the Security setting page.
See “Setting the Security — Security setting Page” on page 30.

Application menu

Preset position

Displays the Preset position setting page.
See “Setting the Camera Position and Action — Preset position setting Page” on page 31.

FTP client

Displays the FTP client setting page.
See “Sending Images to FTP Server — FTP client setting Page” on page 34.

FTP server

Displays the FTP server setting page.
See “Downloading Images from the Camera — FTP server setting Page” on page 37.

SMTP

Displays the SMTP setting page.
See “Sending an Image via E-mail — SMTP setting Page” on page 38.

Alarm out 1

Displays the Alarm out 1 setting page.
See “Setting the Alarm Out 1 or 2 — Alarm out 1 or 2 setting Page” on page 40.

Alarm out 2

Displays the Alarm out 2 setting page.
See “Setting the Alarm Out 1 or 2 — Alarm out 1 or 2 setting Page” on page 40.

Image memory

Displays the Image memory setting page.
See “Recording Images in Memory — Image memory setting Page” on page 41.

Alarm buffer

Displays the Alarm buffer setting page.
See “Setting the Alarm Buffer — Alarm buffer setting Page” on page 45.

Serial

Displays the Serial setting page.
See “Communicating Data via Serial Port — Serial setting Page” on page 45.

Schedule

Displays the Schedule setting page.
See “Setting the Schedule — Schedule setting Page” on page 46.

Activity detection

Displays the Activity detection setting page.
See “Setting the Activity Detection Function — Activity detection setting Page” on page 47.

Pop-up

Displays the Pop-up setting page.
See “Showing the Pop-up — Pop-up setting Page” on page 48.

Buttons common to every setting page

The following buttons are displayed on the setting pages where they are necessary. The functions of the buttons are the same on every setting page.



Click this button to validate the settings.

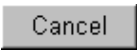

Click this button to invalidate the set values and return to the previous settings.

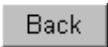

Click this button to return to the top of the setting page.

General notes on setting pages

- After changing a setting on a setting page, wait at least 10 seconds before turning off the power of the camera. If the power is turned off immediately, the changed setting may not be stored correctly.
- When you display the Area setting page or Activity detection setting page, the size of the image on the main viewer page may change for a while. This is not a problem.

Configuring the System — System setting Page

When you click **System** on the Administrator menu, the System setting page appears.
Use this page to perform the principal settings of the software.

System setting Section

Title bar name

Type a name to display on the title bar up to 32 characters.

Welcome text

Type a text to show on the welcome page, in HTML format, up to 1,024 characters. Use the
 tag for a line break. (A line break is equivalent to 2 characters.)

Serial No.

Displays the serial number of the camera.

Default frame rate

Select the initial frame rate which is selected when you log in the camera and display the main viewer page.

Click the down-arrow button in the box and select the frame rate from the drop-down list.

The selectable frame rates are the following:

SNC-RZ30N:

1, 2, 3, 4, 5, 6, 8, 10, 15, 20, 25, Fastest

SNC-RZ30P:

1, 2, 3, 4, 5, 6, 8, 12, 16, 20, Fastest

The numbers indicate “FPS” (the number of frames transmitted per second).

With **Fastest**, the camera transmits the maximum number of frames possible for the connected line. The maximum frame rate is 30 FPS for the SNC-RZ30N and 25 FPS for the SNC-RZ30P.

Note

To update the main viewer page for the changed setting, click **Refresh** of the browser.

Mount

Select **Ceiling** when you install the camera on the ceiling, or **Desk top** when you install it on a desk top.

Notes

- To update the main viewer page for the changed setting, click **Refresh** of the browser.
- This function is inactive when you use the Server push viewer.

Default URL

Select the homepage to be displayed when you enter the IP address of the camera in the Address box of the browser.

To display the homepage built in the camera

Select **/index.html**.

To display your individual homepage

You can display the favorite homepage if you create it using the CGI commands of the camera and store the HTML file in the recommended ATA memory card. In this case, change the Default URL setting as follows:

- 1** Select **User Setting**.
- 2** Store the HTML file of the homepage you created into an ATA memory card and insert the card into the PC card slot of the camera.
The PC card slot located on the lens side is “A slot,” and that on the camera bottom side is “B slot.”
- 3** Select from the drop-down list, **/advr/** when you have inserted the PC card into A slot, or **/bdrv/** when you have inserted it into B slot.
- 4** Type the path of the homepage up to 64 characters.

A-slot (advr)/B-slot (bdrv)

Displays the type of the PC card inserted into the PC card slot and its free card space. The PC card slot located on the lens side is “A-slot,” and that on the camera bottom side is “B-slot.”

Exclusive control mode

Limits the pan/tilt operation of the camera.

If you select **Off**, multiple users can pan/tilt the camera at the same time. The operation by the user accessed later has priority.

If you select **On**, only one user can pan/tilt the camera. The period of operation allowed to one user is determined by the Operation time setting. If a user tries to operate the camera while another user is operating it, the control right is limited according to the Operation time and Maximum wait number settings.

Operation time

Sets the period that one user can operate the camera exclusively, between 10 and 600 sec.

This setting is valid when the Exclusive control mode menu is set to **On**.

Maximum wait number

Sets the maximum number of users that can wait to control the camera while another user is operating the camera. The selectable number is between 0 and 20.

This setting is valid when the Exclusive control mode menu is set to **On**.

Notes

- Before using the Exclusive control mode, you need to set the date and time correctly on this camera and the connected computer.
- When you use the Exclusive control mode, enable the Cookie on your browser. The Exclusive control mode does not function if the Cookie is disabled.
- After you have changed a setting of the Exclusive control mode menu, click **Refresh** of the browser to update for the changed setting.

System log

Click **View** to display the Log file events page.

The Log file events page shows the software version and troubleshooting information.

Access log

Click **View** to display the Access log page.

The Access log page shows the history of accessing the camera.

Date time setting Section

Date time setting	
Current date time	2003-02-19 18:08:11
System(PC) current date time	2003-02-19 18:08:22 <input type="button" value="Apply"/>
Manual current date time (20yy-mm-dd hh:mm:ss)	20 [02] - [01] - [01] [00] : [00] : [00] <input type="button" value="Apply"/>
Time zone selecting	(GMT+09:00) Osaka, Sapporo, Tokyo, Seoul <input type="button" value="Apply"/>
Date time format	yyyy-mm-dd hh:mm:ss <input type="button" value="Apply"/>
Synchronization with NTP server	<input checked="" type="radio"/> On <input type="radio"/> Off <input type="button" value="Apply"/>
	NTP server name Interval time 1 hours

Current date time

Displays the date and time set on the camera. You can set the date and time using the following two methods.

Note

When you purchased the camera, be sure to check the date and time of the camera and set them if necessary.

System (PC) current date time

Displays the date and time set on your computer. Click **Apply** to transfer the computer's date and time to the camera. The set date and time are shown on Current date time.

Manual current date time

When you want to set the camera's date and time manually. Select the lower 2-digits of the year, month, date, hour, minutes and seconds from each drop-down list. Click **Apply** to change the Current date time setting to the date and time you selected.

Time zone selecting

Set the time difference from Greenwich Mean Time in the area where the camera is installed. When you send an E-mail, the sending date and time is adjusted according to this setting. Select the time zone where the camera is installed from the drop-down list. Click **Apply** to change the Current date time setting according to the selection.

Notes

- If the time zone selected on the Time zone selecting menu is different from that set on the computer, the time is adjusted using the time zone difference and set on the camera.

- Due to the network properties, there may be a slight difference between the actual time and the time set on the camera.

Date time format

Select the format of date and time to be displayed on the monitor image from the drop-down list. You can select from among **yyyy-mm-dd hh:mm:ss** (year-month-day hour:minute:second), **mm-dd-yyyy hh:mm:ss** (month-day-year hour:minute:second), and **dd-mm-yyyy hh:mm:ss** (day-month-year hour:minute:second). Click **Apply** to transfer the setting to the camera.

Synchronization with NTP server

Synchronizes the camera's time with that of the NTP (Network Time Protocol) server. Select **On** to activate the time synchronization, and **Off** to deactivate it.

NTP server name

Type the host name or IP address of the NTP server, up to 64 characters. This setting is valid when the Synchronization with NTP server menu is set to **On**.

Interval time

Select the interval at which you want to adjust the camera's time referring to the NTP server' time, between 1 and 24 hours. The set interval is a guide, and does not indicate the exact time. This setting is valid when the Synchronization with NTP server menu is set to **On**.

Note

The time adjusted by this function may be slightly in error depending on the network environments between the camera and the NTP server.

Initialization Section

Initialization	
Backup setting	<input type="button" value="Save"/>
Restore setting	<input type="text"/> <input type="button" value="Browse..."/> <input type="button" value="Apply"/>
Reboot	<input type="button" value="Reboot"/>
Factory default	<input type="button" value="Factory default"/>

Backup setting

Saves the setting data of the camera in a file. Click **Save**, and follow the instructions on the browser to specify the folder and save the setting data of the camera. The file name preset at the factory is "snc-rz30.cfg."

Restore setting

Loads the stored setting data of the camera. Click **Browse** and select the file in which the setting data is stored. Then, click **Apply**, and the camera is adjusted according to the loaded data and restarted.

Notes

- The IP address setting in the Wired LAN setting section (see page 26) on the Network setting page and the IP address setting in the Wireless LAN setting section (see page 27) cannot be set.
- The preset position names specified on the Preset position setting page are set, but the camera positions preset with the Preset position names cannot be set. (see page 31)

Reboot

Reboots the camera. Click **Reboot**, and “The SNC-RZ30 will be rebooted. Are you sure?” appears. Click **OK** to reboot the camera.

Factory default

Resets the camera to the factory settings. Click **Factory default**, and “All configuration information will be initialized as factory setting. Are you sure?” appears. Click **OK** to reset to the factory settings.

Setting the Camera

— Camera setting Page

When you click **Camera** on the Administrator menu, the Camera setting page appears. Use this page to set the functions of the camera.

Note

To update the camera for the changed setting, click **Apply** on the changed item.

Camera setting Section

Camera setting	
Image size	Maximum alarm images change by selecting the list box. 320x240 <input type="button" value="Apply"/>
Image quality	Maximum alarm images change by selecting the list box. Level 5 <input type="button" value="Apply"/>
Image	<input checked="" type="radio"/> Color <input type="radio"/> Monochrome <input type="button" value="Apply"/>
Area setting	<input type="radio"/> On <input checked="" type="radio"/> Off <input type="button" value="Apply"/> <input type="button" value="Area setting"/>
Zoom mode	Full <input type="button" value="Apply"/>
Focus mode	Auto <input type="button" value="Apply"/>
White balance mode	Manual <input type="button" value="Apply"/>
	R Gain: 212 (0 to 255) <input type="button" value="Apply"/>
	B Gain: 179 (0 to 255) <input type="button" value="Apply"/>
Exposure mode	Manual <input type="button" value="Apply"/>
	Shutter: 1/60 sec <input type="button" value="Apply"/>
	Iris: F 2.4 <input type="button" value="Apply"/>
	Gain: 0 dB <input type="button" value="Apply"/>
Exposure compensation	<input checked="" type="radio"/> On <input type="radio"/> Off <input type="button" value="Apply"/>
	0 EV <input type="button" value="Apply"/>
Saturation	0 (-3 to 3) <input type="button" value="Apply"/>
Sharpness	6 (1 to 16) <input type="button" value="Apply"/>
Contrast	0 (-3 to 3) <input type="button" value="Apply"/>
Stabilizer	<input type="radio"/> On <input checked="" type="radio"/> Off <input type="button" value="Apply"/>
Camera reset	<input type="button" value="Apply"/>

Image size

Select the size of the image to be transmitted to the computer.

You can select from among the following options.

SNC-RZ30N:

736 × 480 (Auto), 736 × 480 (Frame), 736 × 480 (Field), 640 × 480 (Auto), 640 × 480 (Frame), 640 × 480 (Field), 320 × 240, 160 × 120

SNC-RZ30P:

736 × 544 (Auto), 736 × 544 (Frame), 736 × 544 (Field), 640 × 480 (Auto), 640 × 480 (Frame), 640 × 480 (Field), 320 × 240, 160 × 120

Frame is suitable for still images, and **Field** is suitable for animation.

If you select **Auto**, the image mode changes between **Frame** and **Field** automatically: **Frame** when the subject is a still object, and **Field** when the subject is moving.

Image quality

Select the image quality from **Level 1** to **Level 10**. A higher level gives a higher image quality, but the frame rate decreases as the data size increases.

Tip

The following table shows the relation between the data size of a 24-bit image (8 bits for each R, G and B), and the compression rate for each Level setting. (in case of 640 × 480 image)

Level	Data size (approx.)	Compression rate (approx.)
1	15 KB	1/60
2	18 KB	1/50
3	22.5 KB	1/40
4	25.7 KB	1/35
5	30 KB	1/30
6	36 KB	1/25
7	45 KB	1/20
8	60 KB	1/15
9	90 KB	1/10
10	180 KB	1/5

Image

Select **Color** or **Monochrome**.

Area setting

When the image size is **736 × 480** or **640 × 480** for the SNC-RZ30N, or **736 × 544** or **640 × 480** for the SNC-RZ30P, you can trim a portion of the image and display the trimmed image on the computer. With the trimming, the transmitting data size, and thus, the network load is reduced and a higher frame rate is obtained.

Select **On** for trimming the image, or **Off** for no trimming.

To trim an image

- 1 Set the Image size menu to **736 × 480** or **640 × 480** for the SNC-RZ30N, or **736 × 544** or **640 × 480** for the SNC-RZ30P.
- 2 Set the Area setting menu to **On**, and click **Apply**.
- 3 Click the Area setting button. A still image is displayed.

- 4 Click on the still image to specify the trimming portion. A red frame that appears when you clicked indicates the trimming portion. The trimming portion is determined as shown below:

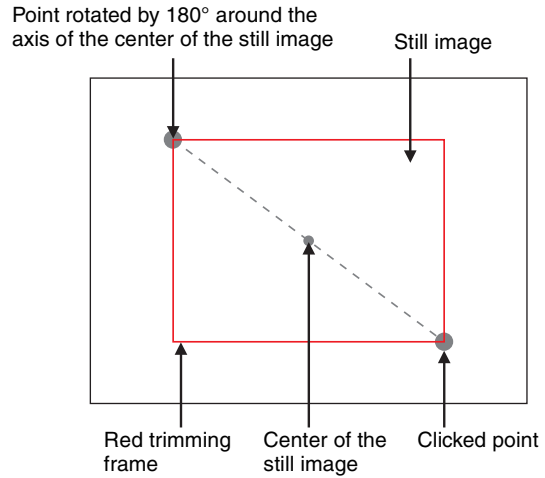

To change the trimming portion, click on another point on the image.

- 5 Click **OK** at the bottom of the window. The trimmed image is displayed on the main viewer page.
- 6 To close the image, click **X** on the upper-right corner.

Zoom mode

Select the zoom mode.

Select **Full** to operate the optical zoom of × 25 and the electronic zoom of × 12, giving × 300 in total. The electronic zoom will operate after the optical zoom. Select **Optical only** to operate the optical zoom of × 25 only. In this case, you can use an electronic zoom of × 2 by clicking the DZOOM x 2 button on the main viewer page. To cancel the electronic zoom, click the DZOOM x 1 button. (See “Zooming” on page 12.)

Focus mode

Select the focus mode.

Select **Auto** to adjust the focus automatically. Select **Manual** to adjust the focus manually using the NEAR and FAR buttons on the main viewer page. If you click the ONE PUSH AF button, the focus is adjusted instantly. (See “Focusing” on page 13.)

White balance mode

Select the white balance mode.

You can select from among **Auto**, **Indoor**, **Outdoor**, **One push WB**, **ATW** and **Manual**.

If you select **One push WB**, the **ONE PUSH TRIGGER** button is displayed. Click the button to adjust the white balance instantly.

If you select **Manual**, the **R Gain** and **B Gain** controls are displayed. Set 0 to 255 for each control.

Exposure mode

Select the exposure from among **Full auto**, **Shutter priority**, **Iris priority** and **Manual**.

The setting items required for each setting appear.

Full auto: Adjusts the exposure automatically using the electronic shutter, iris and gain. Select the Back light compensation menu **On** or **Off**.

Shutter priority: Adjusts the exposure automatically using the iris and gain. Select the electronic shutter speed from the Shutter drop-down list.

Iris priority: Adjusts the exposure automatically using the electronic shutter and gain. For the iris adjustment, select the F number from the Iris drop-down list.

Manual: Select the electronic shutter, iris and gain from the drop-down list for each control.

Back light compensation

Select **On** to activate the backlight compensation, or **Off** to deactivate it.

Shutter

Select the electronic shutter speed from among the following:

SNC-RZ30N:

1/10000, **1/6000**, **1/4000**, **1/3000**, **1/2000**, **1/1000**, **1/725**, **1/500**, **1/350**, **1/250**, **1/180**, **1/125**, **1/100**, **1/90**, **1/60**, **1/30**, **1/15**, **1/8**, **1/4**, **1/2**, **1** (seconds).

SNC-RZ30P:

1/10000, **1/6000**, **1/3500**, **1/3000**, **1/2500**, **1/1750**, **1/1000**, **1/600**, **1/420**, **1/300**, **1/215**, **1/150**, **1/120**, **1/100**, **1/75**, **1/50**, **1/25**, **1/12**, **1/6**, **1/3**, **1/2**, **1** (seconds).

Iris

Select the iris (F number) from among the following: **F1.6**, **F2**, **F2.4**, **F2.8**, **F3.4**, **F4.0**, **F4.8**, **F5.6**, **F5.8**, **F8.0**, **F9.6**, **F11**, **F14**, **F16**, **F19**, **F22**, **F28**, **Close**.

Gain

Select the gain (dB) from among the following: **-3 dB**, **0 dB**, **2 dB**, **4 dB**, **6 dB**, **8 dB**, **10 dB**, **12 dB**, **14 dB**, **16 dB**, **18 dB**, **20 dB**, **22 dB**, **24 dB**, **26 dB**, **28 dB**

Note

When the shutter speed is set to **1 sec** or **1/2 sec** in the **Shutter priority** or **Manual** mode, set the Focus mode menu and the White balance mode menu to **Manual**.

Exposure compensation

When the Exposure mode menu is set to **Full auto**, **Shutter priority** or **Iris priority**, select **On** to activate the exposure compensation, or **Off** to deactivate it.

When it is set to **On**, select the EV value from among the following:

+1.75, **+1.5**, **+1.25**, **+1**, **+0.75**, **+0.5**, **+0.25**, **0**, **-0.25**, **-0.5**, **-0.75**, **-1**, **-1.25**, **-1.5**, **-1.75 (EV)**

Saturation

Select the saturation in 7 steps, from **-3** to **3**.

Selecting **3** gives the image with the highest saturation.

Note

The Saturation setting is effective for the computer image only. (It is not effective for the video signal output.)

Sharpness

Select the sharpness in 16 steps, from **1** to **16**.

Selecting **16** gives the image with the highest sharpness.

Contrast

Select the contrast in 7 steps, from **-3** to **3**.

Selecting **3** gives the image with the highest contrast.

Note

The Contrast setting is effective for the computer image only. (It is not effective for the video signal output.)

Stabilizer

Select the stabilizer to compensate oscillation.

Select **On** to activate the stabilizer when the camera is exposed to oscillation.

Normally select **Off**.

Notes

- If you pan or tilt the camera with the Stabilizer menu set to **On**, it will take about 5 seconds until the monitor image becomes stable after panning or tilting.
- The stabilizer was developed in order to compensate the oscillation generated by human hands. The stabilizer may not be effective depending slightly on the amount of oscillation.
- The view angle differs depending on the Stabilizer On/Off setting.

Camera reset

Click **Apply**, and “Camera reset OK?” appears. Click **OK** on the dialog to reset the camera settings on the Camera setting page to the factory settings.

Day/Night setting Section

Day/Night setting	
Day/Night mode	<input type="radio"/> Disable <input type="radio"/> Auto <input checked="" type="radio"/> Manual <input type="radio"/> Timer
Day/Night	<input type="radio"/> On <input checked="" type="radio"/> Off
<input type="button" value="OK"/> <input type="button" value="Cancel"/>	

Day/Night mode

Select the Day/Night mode that selects the IR (infrared) cut filter operation mode from among **Disable**, **Auto**, **Manual** and **Timer**.

After selecting the mode, click **OK** to update the camera to the selected mode.

Disable: The Day mode is always set.

Auto: The Day/Night mode is set automatically. It is normally set in the Day mode and changes to the Night mode in a dark place.

Manual: Set the Day/Night mode manually. If you select **Manual**, the Day/Night On/Off menu appears. Select **On** to set to the Night mode, and **Off** to the Day mode. You can also select the Day/Night mode from the trigger control parts (see page 14).

Timer: Set the Day/Night mode using the timer. If you select **Timer**, the Schedule No. menu appears at the bottom. Select the schedule so that the Day/Night mode is normally set to the Day mode, and it enters the Night mode at the start time of the schedule and returns to the Day mode at the end time.

Schedule No.

When the Day/Night mode menu is set to **Timer**, click the check box of the desired schedule No.1 to 6 to activate the Day/Night mode. To check the contents of the schedule, click **Schedule check**. (See “Setting the Schedule — Schedule setting Page” on page 46.)

OK/Cancel

See “Buttons common to every setting page” on page 19.

Camera control mode setting Section

You can set the operation mode for panning/tilting using the 8-direction arrow buttons (see page 11), for zooming

using the TELE and WIDE buttons (see page 12), and for manual focusing using the NEAR and FAR buttons (see page 13).

Camera control mode setting	
Mode	<input type="radio"/> Normal <input checked="" type="radio"/> Step
Level	Pan/Tilt <input type="text" value="1"/>
	Zoom <input type="text" value="1"/>
	Focus <input type="text" value="1"/>
<input type="button" value="OK"/> <input type="button" value="Cancel"/>	

Mode

Select the operation mode of the mouse.

Normal: When you click the mouse button, the camera starts panning, tilting or zooming operation, or the focus adjustment starts, and the operation/adjustment continues while you hold down the mouse button. To stop the operation/adjustment, release the mouse button.

Step: Each time you click the mouse button, the camera moves (panning, tilting or zooming) or the focus adjustment operates by a transition level determined by Level. If you keep the mouse button held down for more than 1 second, the operation mode is temporarily changed to Normal. When you release the mouse button, the camera operation/adjustment stops and the Step mode is restored.

Level

Select the transition level of the camera operation or the focus adjustment by clicking the mouse button once. This section is effective when Mode is set to Step.

Pan/Tilt: Select the camera transition level from **1** to **10** by clicking the 8-direction arrow button for panning/tilting (see page 11). Selecting **10** gives the maximum transition level.

Zoom: Select the camera transition level from **1** to **10** by clicking the TELE or WIDE button for zooming (see page 12). Selecting **10** gives the maximum transition level.

Focus: Select the focus adjustment transition level from **1** to **10** by clicking the FAR or NEAR button for manual focusing (see page 13). Selecting **10** gives the maximum transition level.

Note

When you have changed the Mode or Level setting, click the Control button on the menu section to update the setting on the image control section.

Configuring the Network

— Network setting Page

When you click **Network** on the Administrator menu, the Network setting page appears.
Use this page to configure the network to connect the camera and the computer.

Wired LAN setting Section

This section provides the menus for connecting the camera through the Ethernet.

Network setting	
Wired LAN setting	
DHCP	<input checked="" type="radio"/> On <input type="radio"/> Off
DNS auto acquisition	<input type="radio"/> On <input checked="" type="radio"/> Off
IP address	192.168.0.100
Subnet mask	255.0.0.0
Default gateway	
MAC address	08-00-46-21-fb-a6
Primary DNS	
Secondary DNS	
Bandwidth control	Unlimited Mbps
<input type="button" value="OK"/> <input type="button" value="Cancel"/>	

DHCP

Select **On** to assign the IP address to the camera automatically. When you have assigned a proper IP address to the camera, select **Off**.

Note

When you set DHCP to **On**, make sure that there is an DHCP server on the network.

DNS auto acquisition

When DHCP is set to **On**, select if the IP address of the DNS server is assigned automatically or not. Select **On** to assign the IP address of the DNS server automatically.

IP address

Type the IP address of the camera.

Subnet mask

Type the subnet mask.

Default gateway

Type the default gateway.

MAC address

Displays the MAC address of the camera.

Primary DNS

Type the IP address of the primary DNS server.

Secondary DNS

Type the IP address of the secondary DNS server, if necessary.

Bandwidth control

Limits the data communication bandwidth for the Ethernet interface of the camera.

You can select from among the following:

Unlimited, 0.5, 0.6, 0.7, 0.8, 0.9, 1.0, 2.0, 3.0, 4.0, 5.0, 6.0, 7.0, 8.0 (Mbps)

Select **Unlimited** when you do not want to limit the bandwidth.

Notes

- If you limit the bandwidth, the camera performance may be affected, for example, the frame rate of image display may be reduced.
- The actual bandwidth may differ from the selected option depending on the network environments.

OK/Cancel

See “Buttons common to every setting page” on page 19.

Wireless LAN setting Section

This section provides the menus for connecting the camera through a wireless network, with the specified wireless LAN card inserted into the PC card slot of the camera.

Read the Operation Manual and Installation Guide of the wireless LAN card together with this guide.

Verified wireless LAN adapter card

Cisco Aironet 350 Series Client Adapter: AIR-PCM352

For details on the wireless LAN card, consult your authorized Sony dealer or the store where you purchased the product.

Wireless LAN setting		
DHCP	<input checked="" type="radio"/> On <input type="radio"/> Off	
DNS auto acquisition	<input type="radio"/> On <input checked="" type="radio"/> Off	
IP address	10.0.0.100	
Subnet mask	255.0.0.0	
Default gateway		
MAC address	00-00-00-00-00-00	
Primary DNS		
Secondary DNS		
Bandwidth control	Unlimited Mbps	
SSID	snc-rz30	
Type	<input checked="" type="radio"/> 802.11 Ad hoc mode <input type="radio"/> Infrastructure mode Channel: 11 ch Transmit power: 1 mW	
WEP	<input type="radio"/> On <input checked="" type="radio"/> Off	
WEP key data	ID	WEP key
	<input checked="" type="radio"/> 1	
	<input type="radio"/> 2	
	<input type="radio"/> 3	
		Re-type WEP key
<input type="button" value="OK"/> <input type="button" value="Cancel"/>		

DHCP

Select **On** to assign the IP address to the camera automatically. When you have assigned a proper IP address to the camera, select **Off**.

Note

When you set DHCP to **On**, make sure that there is an DHCP server on the network.

DNS auto acquisition

When DHCP is set to **On**, select if the IP address of the DNS server is assigned automatically or not. Select **On** to assign the IP address of the DNS server automatically.

IP address

Type the IP address of the camera.

Subnet mask

Type the subnet mask.

Default gateway

Type the default gateway.

MAC address

Displays the MAC address of the wireless LAN card inserted into the PC card slot of the camera. If no card is inserted, 00-00-00-00-00-00 is displayed.

Primary DNS

Type the IP address of the primary DNS server.

Secondary DNS

Type the IP address of the secondary DNS server, if necessary.

Bandwidth control

Limits the data communication bandwidth for the wireless interface of the camera.

You can select from among the following:

Unlimited, 0.5, 0.6, 0.7, 0.8, 0.9, 1.0, 2.0, 3.0 (Mbps)
 Select **Unlimited** when you do not want to limit the bandwidth.

SSID

Type the ID to identify the wireless network you want to access using up to 32 ASCII characters (upper and lower cases).

For your security, be sure to change the factory setting.

Type

Select the network connection type **802.11 Ad hoc mode** or **Infrastructure mode**. When you select **802.11 Ad hoc mode**, specify the wireless channel and the maximum transmission power.

Specify the channel and transmission power conforming to the regulations of your country or region. For details, refer to the Operation Manual and Installation Guide of the wireless LAN card.

WEP

Select **On** when you use the WEP (Wired Equivalent Privacy) keys, or **Off** when you do not use it.

The WEP key data settings are valid only when the WEP menu is set to **On**.

WEP key data

Specify up to 4 WEP keys. The length of a WEP key is 40 or 104 bit. A 104-bit WEP key has a higher security level than a 40-bit key. You can type the WEP key either in hexadecimal numbers (0 to 9 and A to F) or ASCII characters.

When the Type menu is set to **Infrastructure mode**, the WEP key should be the same as that of the access point. When the Type menu is set to **802.11 Ad hoc mode**, the WEP key should be the same as that of the communication client.

Notes

- Before removing the wireless LAN card from the camera, turn off the power of the camera.
- If a setting either in the Wired LAN setting section or the Wireless LAN setting section has changed, both the Ethernet and wireless interfaces are disconnected and initialized.
- The throughput of the data transmission/reception via the Ethernet may decrease when the wireless LAN card is in use.

HTTP port setting Section

You can set the port number for the HTTP server on the camera.

HTTP port setting	
HTTP Port No.	<input checked="" type="radio"/> 80 <input type="radio"/> <input type="text"/> (1024 to 65535)
<input type="button" value="OK"/> <input type="button" value="Cancel"/>	

HTTP port No.

Normally select **80**. If you want to use a port number other than 80, select the text box and type a port number between 1024 and 65535.

Note

When you have set the HTTP port No. to a number other than 80 on the Network setting page or in the Setup Program, access the camera by typing the IP address of the camera on the web browser, as follows:

Example: when HTTP port No. is set to 8000

Address	http://192.168.0.100:8000/
---------	----------------------------

Notifying the IP Address — Dynamic IP address notification Section

When the DHCP menu is set to **On**, you can send the notification of the completion of the network settings

(Wired LAN settings and Wireless LAN settings) using the SMTP or HTTP protocol.

Dynamic IP address notification		
	<input checked="" type="radio"/> On <input type="radio"/> Off	
SMTP	SMTP server name	smtp.yoursmtpserver.com
	Recipient e-mail address	your_mail@yourmail.com
	From e-mail address	your_mail@yourmail.com
	Subject	Dynamic IP address notification
	Message	The URL is http://<IP>:<HTTPPORT>/ The MAC address is <MACADDRESS>. The model name is <MODELNAME>. The serial number is <SERIAL>.
	<input checked="" type="radio"/> On <input type="radio"/> Off	
HTTP	URL	http://
	Proxy server name	
	Proxy port No.	8080 (1024 to 65535)
	Method	GET
<input type="button" value="OK"/> <input type="button" value="Cancel"/>		

SMTP

Select **On** to send an E-mail when the DHCP setting is completed.

SMTP server name

Type the name or IP address of the SMTP server you want to use for sending an E-mail, up to 64 characters.

Recipient e-mail address

Type the recipient E-mail address up to 64 characters. You can specify only one recipient E-mail address.

From e-mail address

Type the E-mail address that is displayed in the From field of E-mails, up to 64 characters. This is used as the reply address or the address for the system mail from the mail server.

Subject

Type the subject/title of the E-mail up to 64 characters.

Message

Type the text of the E-mail up to 384 characters. You can describe the information of the acquired IP address, etc. using the special tags mentioned below.

HTTP

Select **On** to output a command to the HTTP server when the DHCP setting is completed. Using this function, you can configure a useful system, for example, to view the access log stored in the HTTP server or start an external CGI program.

URL

Specify the URL to send HTTP commands, up to 256 characters. The URL is normally described as follows:

http://ip_address[:port]/path?parameter

ip_address: Type the IP address or host name of the host to which you want to connect.

[:port]: Specify the port number to which you want to connect. If you want to use Well-known port number 80, you do not need to input this value.

Path: Type the command name.

Parameter: Type the command parameter if necessary. You can use the special tags mentioned below for the parameters.

Proxy server name

When you send HTTP commands via a proxy server, type the name or IP address of the proxy server, up to 64 characters.

Proxy port No.

Specify the port number when you send HTTP commands via the proxy server. Set the port number between 1024 and 65535.

Method

Select the HTTP method **GET** or **POST**.

About the special tags

You can use the following five special tags to allow the notification of the settings acquired by the DHCP, such as an IP address. Type the tags in the parameter section of the URL that you describe in the Message field of the SMTP menu.

<IP>

Use this tag to embed the IP address acquired by the DHCP in the text or parameter.

<HTTPPORT>

Use this tag to embed the specified HTTP server port number in the text or parameters.

<MACADDRESS>

Use this tag to embed the MAC address of the interface which IP address you have acquired by the DHCP, in the text or parameter.

<MODELNAME>

Use this tag to embed the camera's model name (SNC-RZ30N or SNC-RZ30P) in the text or parameter.

<SERIAL>

Use this tag to embed the camera's serial number in the text or parameter.

Setting the User

— User setting Page

When you click **User** on the Administrator menu, the User setting page appears.

Use this page to set the user names and passwords of Administrator and up to 9 kinds of users (User 1 to User 9), and the access right of each user.

User ID	User name	Password	Re-type password	Access right
Administrator	admin	*****	*****	Level 4
User 1				No access right
User 2				No access right
User 3				No access right
User 4				No access right
User 5				No access right
User 6				No access right
User 7				No access right
User 8				No access right
User 9				No access right

User access right: Level 4

OK Cancel

Administrator, User 1 to 9

Specify **User name**, **Password**, **Re-type password** and **Access right** for each user ID.

User name

Type a user name between 4 and 16 characters.

Password

Type a password between 4 and 16 characters.

Re-type password

To confirm the password, type the same characters as you typed in the Password box.

Note

If you type an incorrect character in the User name, Password or Re-type password box, a message like the following appears. In this case, click **OK** to cancel the message and re-type the correct character.



Access right

Select the access right for each user from the drop-down list. You can select from **Level 1** to **Level 4**. The rights afforded to each access right are as follows:

- Level 1:** Allows monitoring of the camera image (including some operations for monitoring)
- Level 2:** Allows monitoring of the camera image and camera operations.
- Level 3:** Allows monitoring of the camera image, camera operations and manual application operations.
- Level 4:** Allows all the access right as Administrator.
- No access right:** Use this option when you want to prohibit access to the camera temporarily.

User access right

Select the level of the access right to require user authentication.
The authentication dialog will appear where user authentication is required.

- Level 1:** Performs user authentication when a user accesses the following pages: main viewer page (page 9), Camera control parts (page 11), Trigger control parts (page 14) or Administrator menu page (page 18).
- Level 2:** Performs user authentication when a user accesses the following pages: Camera control parts, Trigger control parts or Administrator menu page. No user authentication is required to display the main viewer page.
- Level 3:** Performs user authentication when a user accesses the following pages: Trigger control parts or Administrator menu page. No user authentication is required to display the main viewer page or the Camera control parts.
- Level 4:** Performs user authentication when a user accesses the Administrator menu page only. No user authentication is required to display the other pages.

OK/Cancel

See “Buttons common to every setting page” on page 19.

Setting the Security — Security setting Page

When you click **Security** on the Administrator menu, the Security setting page appears.
Use this page to limit the computers that can access the camera.

Activating/Deactivating the Security Function — Security usage setting Page

To activate the security function, select **Use security function**, then click **OK**. The Security setting page appears.
If you do not use the security function, select **Do not use security function**, then click **OK**.

Setting the Security Function —Securing setting Page

Security setting		
Default policy	Allow	
Network address/Subnet 1	192.168.0.90 / 32	Allow
Network address/Subnet 2	192.168.1.0 / 24	Deny
Network address/Subnet 3	0.0.0.0 / 8	Allow
Network address/Subnet 4	0.0.0.0 / 8	Allow
Network address/Subnet 5	0.0.0.0 / 8	Allow
Network address/Subnet 6	0.0.0.0 / 8	Allow
Network address/Subnet 7	0.0.0.0 / 8	Allow
Network address/Subnet 8	0.0.0.0 / 8	Allow
Network address/Subnet 9	0.0.0.0 / 8	Allow
Network address/Subnet 10	0.0.0.0 / 8	Allow

Default policy

Select the basic policy of the limit from **Allow** and **Deny**.
If you select **Allow**, you will basically allow access to the camera and only deny access from the computers specified on the Network address/Subnet 1 to Network address/Subnet 10 menus below.
If you select **Deny**, you will basically deny access to the camera, and only allow access from the computers specified on the Network address/Subnet 1 to Network address/Subnet 10 menus.

Network address/Subnet 1 to Network address/Subnet 10

Type the IP addresses and subnet mask values you want to allow or deny access to the camera.

You can specify up to 10 IP addresses and subnet mask values. For a subnet mask, type 8 to 32.

To temporarily cancel the Default Policy for a specified IP address/subnet mask, select **Allow** or **Deny** from the drop-down list on the right.

Tip

The subnet mask value represents the bit number from the left of the network address.

For example, the subnet mask value for 255.255.255.0 is 24.

If you set “192.168.0.0/24, Allow,” you can allow access from the computers having an IP address between 192.169.0.0 and 192.168.0.255.

Note

You can access the camera even from a computer having the IP address whose access right is set to **Deny**, if you enter the user name and password set for Level 4 access right on the authentication dialog displayed.

OK/Cancel

See “Buttons common to every setting page” on page 19.

Setting the Camera Position and Action

— Preset position setting Page

When you click **Preset position** on the Administrator menu, the Preset position setting page appears.

Use this page to store the pan, tilt and zoom positions of the camera (Preset position) in memory and program the sequenced action of the camera (Tour).

Storing the Pan, Tilt and Zoom Positions

— Position preset Section

You can store up to 16 setting of the pan, tilt and zoom positions (Preset positions) of the camera in memory.



Note

For a Preset position setting, you can store the pan, tilt and zoom positions only. Set the Focus mode, Exposure mode and White balance mode menu to **Auto**. (See “Setting the Camera — Camera setting Page” on page 22.)

Preset No.

Select a preset number **1** to **16** from the drop-down list. Click **Preset call** to move the camera to the pan, tilt and zoom positions stored in the selected preset number.

Preset position name

Type a preset position name for the selected preset number up to 32 characters.

Apply

Use this button to store the camera position in a preset number.

To store, proceed as follow:

- 1 Display the monitor image on the main viewer page, and pan, tilt and zoom the camera to the position you want to store as a Preset position.
- 2 Select the Preset No. from the drop-down list and enter the Preset position name.
- 3 Click **Apply**.
The camera position is stored in memory.

Clear

Deletes the Preset position data in the selected preset number.

Moving the Camera to the Preset Position by the Alarm — Position at alarm Section

You can move the camera to the preset position by synchronizing with an external sensor input 1, 2 or 3 or the activity detection function. If an alarm occurs by the external sensor input or the activity detection function, the camera automatically moves to the preset position.

Position at alarm	
Sensor1	2
Sensor2	1
Sensor2	none
Activity detection	none
<input type="button" value="Activity detection"/>	
<input type="button" value="Apply"/> <input type="button" value="Cancel"/>	

Sensor 1/Sensor 2/Sensor 3

Select from the drop-down list the preset number in which the preset position you want to move the camera to is stored. The camera moves to the preset position when an alarm occurs via the corresponding sensor input.

Select **None** if you do not want to move the camera to any preset position.

Activity detection

Select from the drop-down list the preset number in which the preset position you want to move the camera to is stored. The camera moves to the preset position when an alarm occurs by the activity detection function. Click **Activity detection** to display the Activity detection setting page. (See “Setting the Activity Detection Function — Activity detection setting Page” on page 47.)

Apply/Cancel

See “Buttons common to every setting page” on page 19.

Checking the Preset Position Settings — Preset position table Section

Preset position table		
Preset No	Name	Position at alarm
No.1	Door 1	Sensor2
No.2	Door 2	Sensor1
No.3	Exit	
No.4		
No.5	Conference room	
No.6		
No.7		
No.8		
No.9		
No.10		
No.11		
No.12		
No.13		
No.14		
No.15		
No.16		

The table shows the preset position name and preset position setting for each preset number.

Programming the Tour — Tour setting Section

You can program up to 16 preset positions so that the camera moves to multiple preset positions in sequence (Tour).

Tour setting	
Tour name	A
Stay time	1 (1 to 3600sec)
Pan speed	1
Tilt speed	1
Sequence	1 1 end end end end end end end end end end end end end end
<input type="button" value="Apply"/> <input type="button" value="Cancel"/>	

Tour name

Select a tour name from among **A**, **B**, **C**, **D** and **E**.

Stay time

Type a period of time for which the camera is to stay at each preset position, between **1** and **3600** seconds.

Pan speed

Select the pan speed from the drop-down list. You can select the pan speed from **1** to **19** and **Fastest**. The camera pans faster with a higher number setting. With **Fastest**, the camera pans at the maximum speed.

Tilt speed

Select the tilt speed from the drop-down list. You can select the tilt speed from **1** to **15** and **Fastest**. The camera tilts faster with a higher number setting. With **Fastest**, the camera tilts at the maximum speed.

Sequence

Select the preset number **1** to **16** for each of 16 list boxes. The camera moves to the preset positions stored in the selected preset numbers in sequence. The sequence of camera movement starts from the preset position specified in the upper-left list box to the right, then to the lower list boxes from left to right. After the preset position specified in the last list box, the camera returns to the first preset position. This sequence is cyclical. To determine the end of the program, select **end** in a list box. When the camera reaches the preset position specified in the list box before the end, it returns to the first preset position, and the sequence recycles.

Apply/Cancel

See “Buttons common to every setting page” on page 19.

Checking the Tour Settings — Tour table Section

Tour table																												
Tour	Sequence	Speed																										
A	<table border="1"> <tr><td>1</td><td>2</td><td></td><td></td><td></td><td></td><td></td><td></td><td></td><td></td></tr> <tr><td></td><td></td><td></td><td></td><td></td><td></td><td></td><td></td><td></td><td></td></tr> </table>	1	2																			<table border="1"> <tr><td>Stay time</td><td>5</td></tr> <tr><td>Pan speed</td><td>1</td></tr> <tr><td>Tilt speed</td><td>1</td></tr> </table>	Stay time	5	Pan speed	1	Tilt speed	1
1	2																											
Stay time	5																											
Pan speed	1																											
Tilt speed	1																											
B	<table border="1"> <tr><td>1</td><td>2</td><td></td><td></td><td></td><td></td><td></td><td></td><td></td><td></td></tr> <tr><td></td><td></td><td></td><td></td><td></td><td></td><td></td><td></td><td></td><td></td></tr> </table>	1	2																			<table border="1"> <tr><td>Stay time</td><td>5</td></tr> <tr><td>Pan speed</td><td>1</td></tr> <tr><td>Tilt speed</td><td>1</td></tr> </table>	Stay time	5	Pan speed	1	Tilt speed	1
1	2																											
Stay time	5																											
Pan speed	1																											
Tilt speed	1																											
C	<table border="1"> <tr><td>1</td><td>2</td><td>3</td><td>5</td><td></td><td></td><td></td><td></td><td></td><td></td></tr> <tr><td></td><td></td><td></td><td></td><td></td><td></td><td></td><td></td><td></td><td></td></tr> </table>	1	2	3	5																	<table border="1"> <tr><td>Stay time</td><td>1</td></tr> <tr><td>Pan speed</td><td>6</td></tr> <tr><td>Tilt speed</td><td>3</td></tr> </table>	Stay time	1	Pan speed	6	Tilt speed	3
1	2	3	5																									
Stay time	1																											
Pan speed	6																											
Tilt speed	3																											
D	<table border="1"> <tr><td>1</td><td>2</td><td></td><td></td><td></td><td></td><td></td><td></td><td></td><td></td></tr> <tr><td></td><td></td><td></td><td></td><td></td><td></td><td></td><td></td><td></td><td></td></tr> </table>	1	2																			<table border="1"> <tr><td>Stay time</td><td>5</td></tr> <tr><td>Pan speed</td><td>1</td></tr> <tr><td>Tilt speed</td><td>1</td></tr> </table>	Stay time	5	Pan speed	1	Tilt speed	1
1	2																											
Stay time	5																											
Pan speed	1																											
Tilt speed	1																											
E	<table border="1"> <tr><td>1</td><td>2</td><td>3</td><td>16</td><td></td><td></td><td></td><td></td><td></td><td></td></tr> <tr><td></td><td></td><td></td><td></td><td></td><td></td><td></td><td></td><td></td><td></td></tr> </table>	1	2	3	16																	<table border="1"> <tr><td>Stay time</td><td>3</td></tr> <tr><td>Pan speed</td><td>14</td></tr> <tr><td>Tilt speed</td><td>14</td></tr> </table>	Stay time	3	Pan speed	14	Tilt speed	14
1	2	3	16																									
Stay time	3																											
Pan speed	14																											
Tilt speed	14																											

Sequence

Shows the preset numbers in the programmed order for each tour **A** to **E**.

Speed

Shows the stay time, pan speed and tilt speed settings for each tour.

Activating the Tour — Tour selection Section

You can activate the tour according to the schedule.

Tour selection	
Selected tour name	none
Available period	<input checked="" type="radio"/> Always <input type="radio"/> Use scheduler
Schedule No.	<input checked="" type="checkbox"/> 1 <input type="checkbox"/> 2 <input type="checkbox"/> 3 <input type="checkbox"/> 4 <input type="checkbox"/> 5 <input type="checkbox"/> 6 <input type="button" value="Schedule check"/>
Resume time on inactivity	<input checked="" type="radio"/> On <input type="radio"/> Off
	30 (5 to 600sec)
	<input type="button" value="Apply"/> <input type="button" value="Cancel"/>

Selected tour name

Select the tour name **A** to **E** you want to activate. Select **none** if you do not want to activate any tour or if you want to stop the tour in action.

Available period

Select the period for which you can activate the tour.

Always: The tour can be activated any time.

Use scheduler: The tour is activated according to the schedule selected on the Schedule No. menu below.

Schedule No.

When **Use scheduler** is selected on the Available period menu, select the schedule you want to activate the tour (program).

Click to select the check box(es) **1** to **6**. You can select multiple schedules.

To check the contents of schedules, click **Schedule check**. (See “Setting the Schedule — Schedule setting Page” on page 46.)

Resume time on inactivity

Select the tour activity after it has stopped because you have operated (panned/tilted/zoomed) the camera from the camera control section or moved the camera to the preset position by the alarm during the tour in action. If you select **On**, specify the wait time before the tour restarts, between 5 and 600 seconds. The tour restarts automatically after the specified time has elapsed. If you select **Off**, the tour does not restart, and **none** is displayed on Selected tour name.

Note

The camera settings (see page 22) you made during the tour in action may not be valid.

Sending Images to FTP Server

— FTP client setting Page

When you click **FTP client** on the Administrator menu, the FTP client setting page appears.

Use this page to set up for capturing and sending still images to an FTP server. You can capture a still image at the moment when a trigger occurs by an external sensor input, the built-in activity detection function or a manual trigger button, or capture sequenced still images before and after the trigger. The captured still image(s) is sent to the FTP server (FTP client function). You can also send still images periodically.

Activating/Deactivating the FTP Client Function

— FTP client usage setting Page

FTP client usage setting	
<input type="radio"/>	Use FTP client function
<input checked="" type="radio"/>	Do not use FTP client function
<input type="button" value="OK"/> <input type="button" value="Cancel"/>	

To activate the FTP client function, select **Use FTP client function** and click **OK**. The FTP client setting page appears.

When you do not use the FTP client function, select **Do not use FTP client function** and click **OK**.

Notes

- The frame rate and operability on the main viewer page may decrease while a file is being transmitted by the FTP client function.
- If the camera is installed on a desk top, the sent still image is upside down.

Setting the FTP Client Function

— FTP client setting Page

FTP client setting	
FTP server name	<input type="text" value="ftp.yourftpserver.com"/>
User name	<input type="text" value="anonymous"/>
Password	<input type="password" value="*****"/>
Re-type password	<input type="password" value="*****"/>
Remote path	<input type="text" value="/"/>
Image file name	<input type="text" value="image"/>
Suffix	<input type="radio"/> None <input checked="" type="radio"/> Date/Time <input type="radio"/> Sequence number
Sequence No. clear	<input type="button" value="Apply"/>
Mode	<input checked="" type="radio"/> Manual <input type="radio"/> Alarm <input type="radio"/> Periodical sending
<input type="button" value="Back"/> <input type="button" value="OK"/>	

FTP server name

Type the FTP server name to upload still images up to 64 characters, or the IP address of the FTP server.

User name

Type the user name for the FTP server.

Password

Type the password for the FTP server.

Re-type password

To confirm the password, type the same characters as you typed in the Password box.

Remote path

Type the path to the destination up to 64 characters.

Image file name

Type the basic file name you want to assign to the images when sending to the FTP server. You can use up to 6 alphanumeric, - (hyphen) and _ (underscore) for naming.

Suffix

Select the suffix to add to the file name.

None: No suffix is added. The basic file name is assigned to the image to be sent to the FTP server.

Date/Time: The date/time suffix is added to the file name.

The date/time suffix consists of lower two-digits of year (2 digits), month (2 digits), date (2 digits), hour (2 digits), minute (2 digits), second (2 digits) and consecutive number (2 digits), thus 14-digit number is added to the file name.

Sequence number: A consecutive number is added to the basic file name. A number of up to 10 digits between 0000000000 and 4294967295 is added to the file name.

Tip

When the Mode menu is set to **Alarm**, the type of alarm and the capture timing to the alarm are added to the suffix.

Type of alarm: **S1** (Sensor 1), **S2** (Sensor 2), **S3** (Sensor 3), **AD** (Activity Detection)

Capture timing: **PR** (Pre-alarm), **JT** (Just alarm), **PT** (Post-alarm)

Sequence No. clear

Click **Apply** to reset the Sequence number suffix to 0.

Mode

Select the mode of the FTP client function.

Manual: Sends still images to the FTP server manually. After selecting **Manual**, click **OK**. The FTP client function mode is set to **Manual**.

In this mode, when you click the  (Trigger) button on the main viewer page, a still image is captured and sent to the FTP server. (See “Controlling the Application Manually” on page 14.)

Alarm: Sends still images to the FTP server by synchronizing with an external sensor input or the built-in activity detection function. When you select **Alarm**, the Alarm mode setting section appears (see page 35).

Note

If the Suffix menu is set to **None**, you cannot select the **Alarm** mode. When you want to use the Alarm mode, set the Suffix menu to **Date/Time** or **Sequence number**.

Periodical sending: Sends still images to the FTP server periodically. When you select **Periodical sending**, the Periodical sending mode setting section appears (see page 35).

Back/OK

See “Buttons common to every setting page” on page 19.

Alarm mode setting Section

Alarm	<input checked="" type="checkbox"/> Sensor 1 <input type="checkbox"/> Sensor 2 <input type="checkbox"/> Sensor 3 <input type="checkbox"/> Activity detection	<input type="button" value="Activity detection"/>
Available period	<input checked="" type="radio"/> Always <input type="radio"/> Use scheduler	
Schedule No.	<input checked="" type="checkbox"/> 1 <input type="checkbox"/> 2 <input type="checkbox"/> 3 <input type="checkbox"/> 4 <input type="checkbox"/> 5 <input type="checkbox"/> 6	<input type="button" value="Schedule check"/>
Alarm buffer configuration	<input type="button" value="Alarm buffer"/>	
Digest viewer	<input checked="" type="radio"/> On <input type="radio"/> Off	
<input type="button" value="Back"/> <input type="button" value="OK"/>		

Alarm

Select the alarm to link the FTP client function. If the selected alarm is detected, the still images before and after the alarm are captured sequentially and sent to the FTP server.

Sensor 1: External sensor connected to sensor input 1 of the camera I/O port

Sensor 2: External sensor connected to sensor input 2 of the camera I/O port

Sensor 3: External sensor connected to sensor input 3 of the camera I/O port

Activity detection: The activity detection function built in the camera

To set the activity detection function, click **Activity**

detection. The Activity detection setting page appears (see page 47).

Available period

Select the period for which the selected alarm mode is available.

Always: The selected alarm mode is available any time.

Use scheduler: The selected alarm mode is available according to the schedule selected in Schedule No. below.

Schedule No.

When **Use scheduler** is selected on the Available period menu, select the schedule you want the selected alarm mode being available.

Click to select the check box(es) **1** to **6**. You can select multiple schedules.

To check the contents of schedules, click **Schedule check**. (See “Setting the Schedule — Schedule setting Page” on page 46.)

Alarm buffer configuration

Click **Alarm buffer** to display the Alarm buffer setting page.

For details, see “Setting the Alarm Buffer — Alarm buffer setting Page” on page 45.

Note

If an alarm occurs during the Alarm buffer processing, that alarm is ignored.

Digest viewer

If you select **On**, an HTML file (.html) and a Java Script file (.js) are added each time the selected alarm is detected.

When you open the added HTML file using a general browser, the digest viewer runs and you can view the still pictures in the alarm buffer in sequence (quasi-animation).

See “Operating the Digest Viewer” on page 36.

Periodical sending mode setting Section

Interval time	<input type="text" value="00"/> H <input type="text" value="10"/> M <input type="text" value="00"/> S
Available period	<input checked="" type="radio"/> Always <input type="radio"/> Use scheduler
Schedule No.	<input checked="" type="checkbox"/> 1 <input type="checkbox"/> 2 <input type="checkbox"/> 3 <input type="checkbox"/> 4 <input type="checkbox"/> 5 <input type="checkbox"/> 6
<input type="button" value="Schedule check"/>	

Interval time

Type the interval at which you want to send images to the FTP server periodically. You can set the hour (H), minutes (M) and seconds (S) between 1 second and 24 hours (one day).

Note

The actual interval may be longer than the set value, depending on the image size and the network environments.

Available period

Select the period for which the periodical sending mode is available.

Always: The periodical sending mode is available any time.

Use scheduler: The periodical sending mode is available according to the schedule selected in Schedule No. below.

Schedule No.

When **Use scheduler** is selected on the Available period menu, select the schedule you want the periodical sending mode being available.

Click to select the check box(es) **1** to **6**. You can select multiple schedules.

To check the contents of schedules, click **Schedule check**. (See “Setting the Schedule — Schedule setting Page” on page 46.)

Operating the Digest Viewer

If you download the HTML file, the Java Script file and the JPEG image files to your computer and open HTML file using a general browser, the digest viewer is displayed on the screen.

Digest viewer

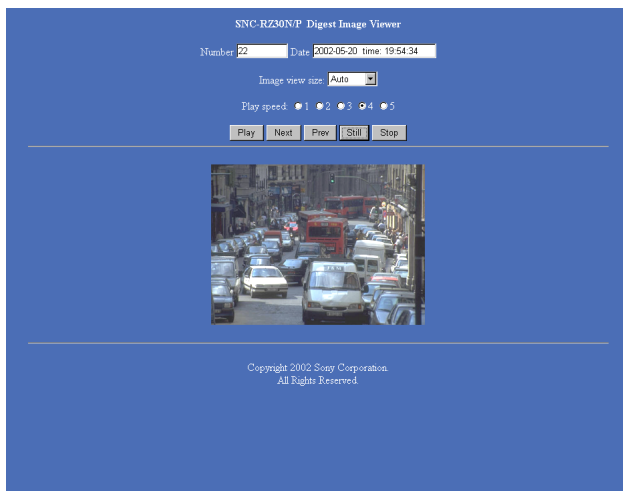

Number

Displays the consecutive still image number.

Date

Displays the date and time when the image is captured.

Image view size

Select the image size to be displayed on the digest viewer from among the following: **Auto**, **160 × 120**, **320 × 240**, **640 × 480**

When you select **Auto**, the image is displayed in the size specified with the Image size menu on the Camera setting page (see page 22).

Play speed

Select the play speed from **1** to **5**. **5** is the highest speed.

Note

Whether you can play the image at a high speed depends on the performance of your computer. You may need to select a lower speed.

Play

Click this button to start playing. Playing stops when the last still image is displayed.

Next

When a still image is displayed, click this button to display the next numbered still image.

Prev (previous)

When a still image is displayed, click this button to display the previous numbered still image.

Still

Click this button to stop playing temporarily.

Stop

Click to stop playing. The still image of number 1 is displayed.

Downloading Images from the Camera

— FTP server setting Page

When you click **FTP server** on the Administrator menu, the FTP server setting page appears.

Use this page to set up for the FTP server function which finds a specified still image file stored in the built-in memory of the camera (about 8 MB) or the ATA memory card inserted into the PC card slot, or download the still image file from the card.

Activating/Deactivating the FTP Server Function

— FTP server usage setting Page

To activate the FTP server function, select **Use FTP server function** and click **OK**. The FTP server setting page appears.

When you do not use the FTP server function, select **Do not use FTP server function** and click **OK**.

Notes

- The frame rate and operability on the main viewer page may decrease when the FTP server function is used.
- Deactivate the FTP server function before removing the ATA memory card or turning off the power of the camera with the ATA memory card inserted.

Setting the FTP Server Function

— FTP server setting Page

You can register up to 10 user names and passwords to allow logging in the camera using the FTP client software of the computer.

Built-in memory

Displays the free space of the built-in memory of the camera.

A-slot (adrv)/B-slot (bdrv)

Displays the type of the PC card inserted into the PC card slot and its free card space. The PC card slot located on the lens side is “A-slot,” and that on the camera bottom side is “B-slot.”

Selected root directory

Select from the drop-down list, the directory under which the image file you want to find or download is stored.

Built-in memory: Built-in memory of the camera

ATA memory card (A-slot): ATA memory card inserted into A slot of the camera

ATA memory card (B-slot): ATA memory card inserted into B slot of the camera

User ID

Type a user name between 4 and 16 characters.

Password

Type a password between 4 and 16 characters.

Re-type password

To confirm the password, type the same characters as you typed in the Password box.

Back/OK

See “Buttons common to every setting page” on page 19.

Sending an Image via E-mail — SMTP setting Page

When you click **SMTP** on the Administrator menu, the SMTP setting page appears.

Use this page to set up for the SMTP function that can capture and send a still image attached to an E-mail. You can capture a still image at the moment when a trigger occurs by an external sensor input, the built-in activity detection function or a manual trigger button. The captured still image is sent as an attachment of the E-mail. You can also send a still image periodically.

Activating/Deactivating the SMTP Function — SMTP usage setting Page

SMTP usage setting	
<input type="radio"/>	Use SMTP function
<input checked="" type="radio"/>	Do not use SMTP function
<input type="button" value="OK"/> <input type="button" value="Cancel"/>	

To activate the SMTP function, select **Use SMTP function** and click **OK**. The SMTP setting page appears.

When you do not use the SMTP function, select **Do not use SMTP function** and click **OK**.

Notes

- The frame rate and operability on the main viewer page may decrease while an image file is being transmitted via an E-mail.
- If the camera is installed on a desk top, the sent still image is upside down.

Setting the SMTP Function — SMTP setting Page

SMTP setting	
SMTP server name	smtp.yoursmtpserver.com
Recipient e-mail address	your_mail@yourmail.com
	user1_mail@yourmail.com
Administrator e-mail address	your_mail@yourmail.com
	user2_mail@yourmail.com
Subject	Test
Message	Captured image.
Image file name	image
Suffix	<input type="radio"/> None <input checked="" type="radio"/> Date/Time <input type="radio"/> Sequence number
Sequence No. clear	<input type="button" value="Apply"/>
Mode	<input checked="" type="radio"/> Manual <input type="radio"/> Alarm <input type="radio"/> Periodical sending
<input type="button" value="Back"/> <input type="button" value="OK"/>	

SMTP server name

Type the SMTP server name up to 64 characters, or the IP address of the SMTP server.

Recipient e-mail address

Type the recipient E-mail address up to 64 characters. You can specify up to three recipient E-mail addresses.

Administrator e-mail address

Type the Administrator e-mail address up to 64 characters.

This address is used for reply mail and sending error messages from the camera.

Subject

Type the subject/title of the E-mail up to 64 characters.

Message

Type the text of the E-mail up to 384 characters. (A line break is equivalent to 2 characters.)

Image file name

Type the basic file name you want to assign to the image to attach an E-mail. You can use up to 6 alphanumeric, - (hyphen) and _ (underscore) for naming.

Suffix

Select the suffix to add to the file name.

None: No suffix is added. The basic file name is assigned to the image to be sent via an E-mail.

Date/Time: The date/time suffix is added to the file name.

The date/time suffix consists of lower two-digits of year (2 digits), month (2 digits), date (2 digits), hour (2 digits), minute (2 digits) and second (2 digits), thus 12-digit number is added to the file name.

Sequence number: A consecutive number is added to the basic file name. A number of up to 10 digits between 0000000000 and 4294967295 is added to the file name.

Sequence No. clear

Click **Apply** to reset the Sequence number suffix to 0.

Mode

Select the mode of the SMTP function.

Manual: Sends a still image attached to an E-mail manually. After selecting **Manual**, click **OK**. The SMTP function mode is set to **Manual**.

In this mode, when you click the  (Trigger) button on the main viewer page, a still image is

captured and sent via an E-mail. (See “Controlling the Application Manually” on page 14.)

Alarm: Sends a still image via an E-mail by synchronizing with an external sensor input or the built-in activity detection function. When you select **Alarm**, the Alarm mode setting section appears (see page 39).

Periodical sending: Sends a still image via an E-mail periodically. When you select **Periodical sending**, the Periodical sending mode setting section appears (see page 39).

Back/OK

See “Buttons common to every setting page” on page 19.

Alarm mode setting Section

Alarm	<input checked="" type="checkbox"/> Sensor 1
	<input type="checkbox"/> Sensor 2
	<input type="checkbox"/> Sensor 3
	<input type="checkbox"/> Activity detection Activity detection
Available period	<input checked="" type="radio"/> Always <input type="radio"/> Use scheduler
Schedule No.	<input checked="" type="checkbox"/> 1 <input type="checkbox"/> 2 <input type="checkbox"/> 3 <input type="checkbox"/> 4 <input type="checkbox"/> 5 <input type="checkbox"/> 6 Schedule check
Back OK	

Alarm

Select the alarm to link the SMTP function. If the selected alarm is detected, a still image is captured and sent via an E-mail.

Sensor 1: External sensor connected to sensor input 1 of the camera I/O port

Sensor 2: External sensor connected to sensor input 2 of the camera I/O port

Sensor 3: External sensor connected to sensor input 3 of the camera I/O port

Activity detection: The activity detection function built in the camera.

To set the activity detection function, click **Activity detection**. The Activity detection setting page appears (see page 47).

Note

The image that can be attached to an E-mail is the one captured at the moment when an alarm is input. If the next alarm occurs while the captured image is being processed, that alarm is ignored.

Available period

Select the period for which the alarm mode is available.
Always: The alarm mode is available any time.

Use scheduler: The alarm mode is available according to the schedule selected on the Schedule No. menu below.

Schedule No.

When **Use scheduler** is selected on the Available period menu, select the schedule you want the alarm mode being available.

Click to select the check box(es) **1** to **6**. You can select multiple schedules.

To check the contents of schedules, click **Schedule check**. (See “Setting the Schedule — Schedule setting Page” on page 46.)

Periodical sending mode setting Section

Interval time	01 H 00 M (More than 30 min)
Available period	<input checked="" type="radio"/> Always <input type="radio"/> Use scheduler
Schedule No.	<input checked="" type="checkbox"/> 1 <input type="checkbox"/> 2 <input type="checkbox"/> 3 <input type="checkbox"/> 4 <input type="checkbox"/> 5 <input type="checkbox"/> 6 Schedule check

Interval time

Type the interval at which you want to send an E-mail with a still image periodically. You can set the hour (H) and minutes (M) between 30 minutes and 24 hours (one day).

Available period

Select the period for which the periodical sending mode is available.

Always: The periodical sending mode is available any time.

Use scheduler: The periodical sending mode is available according to the schedule selected on the Schedule No. menu below.

Schedule No.

When **Use scheduler** is selected on the Available period menu, select the schedule you want the periodical sending mode being available.

Click to select the check box(es) **1** to **6**. You can select multiple schedules.

To check the contents of schedules, click **Schedule check**. (See “Setting the Schedule — Schedule setting Page” on page 46.)

Setting the Alarm Out 1 or 2

— Alarm out 1 or 2 setting Page

When you click **Alarm out 1** on the Administrator menu, the Alarm out 1 setting page appears. When you click **Alarm out 2** on the Administrator menu, the Alarm out 2 setting page appears.

Use these pages to set up for the Alarm out function that controls the alarm out 1 or alarm out 2 of the I/O port located on the rear the camera. You can control the alarm out when a trigger occurs by an external sensor input, the built-in activity detection function, a manual trigger button, the Day/Night function or the timer. The setting items for alarm out 1 and alarm out 2 are the same. This section explains how to set alarm out 1 as an example.

Activating/Deactivating the Alarm Out 1 Function

— Alarm out 1 usage setting Page

To activate the Alarm out 1 function, select **Use alarm out 1 function** and click **OK**. The Alarm out 1 setting page appears.

When you do not use the Alarm out 1 function, select **Do not use alarm out 1 function** and click **OK**.

Setting the Alarm Out 1 Function

— Alarm out 1 setting Page

Mode

Select the mode of the Alarm out 1 function.

Manual: Controls the alarm out 1 manually.

In this mode, you can short-circuit and open the alarm out 1 by clicking the  (Trigger) button on the main viewer page. (See “Controlling the Application Manually” on page 14.)

Day/Night: Controls alarm out 1 by synchronizing with the Day/Night function of the camera. When you select **Day/Night**, the **Day/Night setting** button

appears. Click the button, and the Camera setting page appears and you can set the Day/Night function (see page 25).

In the Night mode, the relay corresponding to the alarm out 1 is short-circuited. In the Day mode, it is open.

Alarm: Controls alarm out 1 by synchronizing with an external sensor input or the built-in activity detection function. When you select **Alarm**, the Alarm mode setting section appears (see page 40).

Timer: Controls alarm out 1 by the timer. When you select **Timer**, the Timer mode setting section appears (see page 41).

Alarm mode setting Section

Alarm

Select the alarm to link the alarm out 1 function. If the selected alarm is detected, the alarm out 1 status changes.

Sensor 1: External sensor connected to sensor input 1 of the camera I/O port

Sensor 2: External sensor connected to sensor input 2 of the camera I/O port

Sensor 3: External sensor connected to sensor input 3 of the camera I/O port

Activity detection: The activity detection function built in the camera.

To set the activity detection function, click **Activity detection**. The Activity detection setting page appears (see page 47).

Available period

Select the period for which the alarm mode is available.

Always: The alarm mode is available any time.

Use scheduler: The alarm mode is available according to the schedule selected on the Schedule No. menu below.

Schedule No.

When **Use scheduler** is selected on the Available period menu, select the schedule you want the alarm mode being available.

Click to select the check box(es) **1** to **6**. You can select multiple schedules.

To check the contents of schedules, click **Schedule check**. (See “Setting the Schedule — Schedule setting Page” on page 46.)

Alarm duration

Select the duration for which the alarm output is short-circuited between 1 and 60 sec.

Timer mode setting Section

Schedule No.	<input checked="" type="checkbox"/> 1 <input type="checkbox"/> 2 <input type="checkbox"/> 3 <input type="checkbox"/> 4 <input type="checkbox"/> 5 <input type="checkbox"/> 6	Schedule check
Back		OK

Schedule No.

Select the schedule you want to activate the alarm out 1 timer mode.

Click to select the check box(es) **1 to 6**. You can select multiple schedules.

The alarm out 1 is short-circuited at the start time of the selected schedule, and it switches to open at the end time.

To check the contents of schedules, click **Schedule check**. (See “Setting the Schedule — Schedule setting Page” on page 46.)

Recording Images in Memory

— Image memory setting Page

When you click **Image memory** on the Administrator menu, the Image memory setting page appears.

Use this page to set up for the image memory function which captures a still image and records it in the built-in memory of the camera (about 8 MB) or the ATA memory card. You can capture a still image at the moment when a trigger occurs by an external sensor input, the built-in activity detection function or a manual trigger button. The captured still image is recorded in the built-in memory or the ATA memory card. You can also record a still image periodically.

The recorded image file can be found or downloaded to the computer using the FTP server function. (See “Downloading Images from the Camera — FTP server setting Page” on page 37.)

Activating/Deactivating the Image Memory Function — Image memory usage setting Page

Image memory usage setting	
Built-in memory	Free space : 8315392byte
A-slot(adrv)	empty
B-slot(b drv)	empty
<input checked="" type="radio"/> Use image memory function	
<input type="radio"/> Do not use image memory function	
Memory	<input checked="" type="radio"/> Built-in memory
	<input type="radio"/> ATA memory card(A-slot)
	<input type="radio"/> ATA memory card(B-slot)
OK Cancel	

Built-in memory

Displays the free space of the built-in memory of the camera.

A-slot/B-slot

Displays the type of the PC card inserted into the PC card slot and its free card space. The PC card slot located on the lens side is “A-slot,” and that on the camera bottom side is “B-slot.”

Use image memory function/Do not use image memory function

To activate the Image memory function, select **Use image memory function** and click **OK**. The Image memory setting page appears.

When you do not use the Image memory function, select **Do not use image memory function** and click **OK**.

Memory

Select the memory you want to store the image to, from the drop-down list.

Built-in memory: Built-in memory of the camera (about 8 MB)

ATA memory card (A-slot): ATA memory card inserted into A slot of the camera

ATA memory card (B-slot): ATA memory card inserted into B slot of the camera

Notes

- The image recorded in the built-in memory will be erased when the power of the camera is turned off.
- The frame rate and operability on the main viewer page may decrease during image storage.
- If the camera is installed on a desk top, the recorded still image is upside down.
- Deactivate the image memory function before removing the ATA memory card or turning off the power of the camera with the ATA memory card inserted.

Recording an Image in the Selected Memory — Image memory setting Page

Image memory setting[Built-in memory]	
Image file name	<input type="text" value="image"/>
Suffix	<input type="radio"/> None <input checked="" type="radio"/> Date/Time <input type="radio"/> Sequence number
Sequence No. Clear	<input type="button" value="Apply"/>
Overwrite	<input type="radio"/> On <input checked="" type="radio"/> Off
Capacity warning	<input checked="" type="radio"/> On <input type="radio"/> Off
	SMTP server name <input type="text"/>
	Administrator e-mail address <input type="text"/>
Mode	<input checked="" type="radio"/> Manual <input type="radio"/> Alarm <input type="radio"/> Periodical recording
<input type="button" value="Back"/> <input type="button" value="OK"/>	

Image file name

Type the basic file name you want to assign to the images when saving in the memory. You can use up to 6 alphanumeric, - (hyphen) and _ (underscore) for naming.

Suffix

Select the suffix to add to the file name.

None: No suffix is added. The basic file name is assigned to the image to be recorded in memory.

Date/Time: The date/time suffix is added to the file name.

The date/timer suffix consists of lower two-digits of year (2 digits), month (2 digits), date (2 digits), hour (2 digits), minute (2 digits), second (2 digits) and

consecutive number (2 digits), thus 14-digit number is added to the file name.

Sequence number: A consecutive number is added to the basic file name. A number of up to 10 digits between 0000000000 and 4294967295 is added to the file name.

Tip

When the Mode menu is set to **Alarm**, the type of alarm and the capture timing to the alarm are added to the suffix.

Type of alarm: **S1** (Sensor 1), **S2** (Sensor 2), **S3** (Sensor 3), **AD** (Activity Detection)

Capture timing: **PR** (Pre-alarm), **JT** (Just alarm), **PT** (Post-alarm)

Sequence No. clear

Click **Apply** to reset the Sequence number suffix to 0.

Overwrite

Select if you overwrite the file or not when there is insufficient memory space to record the image.

Select **On** to allow overwriting. The oldest file or folder is overwritten first.

Select **Off** to prohibit overwriting. In this case, a new file cannot be stored.

Capacity warning

Select **On** to send a warning mail to the Administrator when the built-in memory space is low or the memory is full due to activation of the image memory function.

Select **Off** if you do not want to send a warning mail.

If **On** is selected, the SMTP server name and Administrator e-mail address menus appear.

SMTP server name

Type the name or IP address of the SMTP server you want to use for sending the E-mail, up to 64 characters.

Administrator e-mail address

Type the E-mail address of the recipient of the warning mail (E-mail address of the Administrator), up to 64 characters.

Mode

Select the mode of the Image memory function.

Manual: Records a still image in the selected memory manually.

In this mode, when you click the  (Trigger) button on the main viewer page, a still image is captured and recorded in the selected memory. (See “Controlling the Application Manually” on page 14.)

Alarm: Records a still image in the selected memory by synchronizing with an external sensor input or the built-in activity detection function. When you select **Alarm**, the Alarm mode setting section appears (see page 43).

Note

If the Suffix menu is set to **None**, you cannot select the **Alarm** mode. When you want to use the Alarm mode, set the Suffix menu to **Date/Time** or **Sequence number**.

Periodical recording:Records still images in the selected memory periodically. When you select **Periodical recording**, the Periodical recording mode setting section appears (see page 43).

Alarm mode setting Section

Alarm	<input checked="" type="checkbox"/> Sensor 1 <input type="checkbox"/> Sensor 2 <input type="checkbox"/> Sensor 3 <input type="checkbox"/> Activity detection	Activity detection
Available period	<input checked="" type="radio"/> Always <input type="radio"/> Use scheduler	
Schedule No.	<input checked="" type="checkbox"/> 1 <input type="checkbox"/> 2 <input type="checkbox"/> 3 <input type="checkbox"/> 4 <input type="checkbox"/> 5 <input type="checkbox"/> 6	Schedule check
Alarm buffer configuration	Alarm buffer	
Digest viewer	<input checked="" type="radio"/> On <input type="radio"/> Off	
Back OK		

Alarm

Select the alarm to link the Image memory function. If the selected alarm is detected, a still image is captured and recorded in the selected memory.

Sensor 1: External sensor connected to sensor input 1 of the camera I/O port

Sensor 2: External sensor connected to sensor input 2 of the camera I/O port

Sensor 3: External sensor connected to sensor input 3 of the camera I/O port

Activity detection: The activity detection function built in the camera.

To set the activity detection function, click **Activity detection**. The Activity detection setting page appears (see page 47).

Available period

Select the period for which the alarm mode is available.

Always: The alarm mode is available any time.

Use scheduler: The alarm mode is available according to the schedule selected in the Schedule No. menu below.

Schedule No.

When **Use scheduler** is selected on the Available period menu, select the schedule you want the alarm mode being available.

Click to select the check box(es) **1** to **6**. You can select multiple schedules.

To check the contents of schedules, click **Schedule check**. (See “Setting the Schedule — Schedule setting Page” on page 46.)

Alarm buffer configuration

Click **Alarm buffer** to display the Alarm buffer setting page.

For details, see “Setting the Alarm Buffer — Alarm buffer setting Page” on page 45.

Note

If an alarm occurs during the Alarm buffer processing, that alarm is ignored.

Digest viewer

If you select **On**, an HTML file (.html) and a Java Script file (.js) are added each time the selected alarm is detected.

When you open the added HTML file using a general browser, the digest viewer runs and you can view the still pictures in the alarm buffer in sequence (quasi-animation).

See “Operating the Digest Viewer” on page 36.

Periodical recording mode setting Section

Interval time	00 H 10 M 00 S
Available period	<input checked="" type="radio"/> Always <input type="radio"/> Use Scheduler
Schedule No.	<input checked="" type="checkbox"/> 1 <input type="checkbox"/> 2 <input type="checkbox"/> 3 <input type="checkbox"/> 4 <input type="checkbox"/> 5 <input type="checkbox"/> 6
Digest viewer	<input type="radio"/> On <input checked="" type="radio"/> Off
Back OK	

Interval time

Type the interval at which you want to record an image periodically. You can set the hour (H), minutes (M) and seconds (S) between 1 second and 24 hours (one day).

Note

The actual interval may be longer than the set value, depending on the image size and the recording conditions of the ATA memory card.

Available period

Select the period for which the periodical recording mode is available.

Always: The periodical recording mode is available any time.

Use scheduler: The periodical recording mode is available according to the schedule selected in the Schedule No. menu below.

Schedule No.

When **Use scheduler** is selected on the Available period menu, select the schedule you want the periodical recording mode being available.

Click to select the check box(es) **1** to **6**. You can select multiple schedules.

To check the contents of schedules, click **Schedule check**. (See “Setting the Schedule — Schedule setting Page” on page 46.)

Digest viewer

If you select **On**, an HTML file (.html) and a Java Script file (.js) are added every 100 files.

When you open the added HTML file using a general browser, the digest viewer runs and you can view the still pictures in the alarm buffer in sequence (quasi-animation).

See “Operating the Digest Viewer” on page 36.

Note

If the Suffix menu is set to **None**, you cannot select **On**. When you want to use the digest viewer, set the Suffix menu to **Date/Time** or **Sequence number**.

Back/OK

See “Buttons common to every setting page” on page 19.

Directory Structure of Image Memory

The images are recorded in the memory with the following directory structure.

ATA memory card (A-slot): Slot A

ATA memory card (B-slot): Slot B

Built-in memory: Drive C

Each slot or drive has the following directory structure.

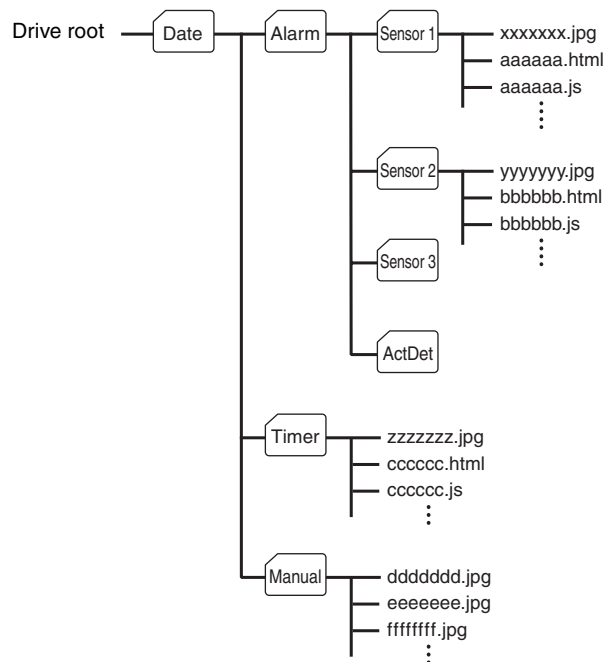

A represents a folder created automatically. The Date folder has a 6-digit folder name consisting of the lower two digits of year (2 digits), month (2 digits) and date (2 digits). The Sensor 1, Sensor 2, Sensor 3 and Act Det (activity detection) folders correspond to alarm modes. The Timer folder corresponds to the periodical recording mode. And, the Manual folder corresponds to the manual mode.

JPEG image files are stored in each folder. If the digest viewer is allowed, an HTML file (.html) and a Java Script file (.js) are created automatically at the time of each alarm event. For the periodical recording mode, an HTML file (.html) and a Java Script file (.js) are created automatically every 100 JPEG image files.

Setting the Alarm Buffer — Alarm buffer setting Page

When you click **Alarm buffer** on the Administrator menu, the Alarm buffer Setting page appears. Use this page to set up for the alarm buffer used in the FTP client function (see page 34) and the Image memory function (see page 41).

Alarm buffer setting	
Recording interval	1/5 sec
Pre-alarm images	10
Post-alarm images	10
Maximum alarm images	654
<input type="button" value="OK"/> <input type="button" value="Cancel"/>	

Recording interval

Select the interval (in seconds) at which you want to record an image in the alarm buffer.

You can select from among the following intervals:
SNC-RZ30N:

1/30, 1/15, 1/10, 1/5, 1/2, 1, 2, 3, 4, 5, 6, 7, 8, 9, 10
(seconds)

SNC-RZ30P:

1/25, 1/12, 1/8, 1/5, 1/2, 1, 2, 3, 4, 5, 6, 7, 8, 9, 10
(seconds)

Pre-alarm images

Type the number of images to be recorded before detecting an alarm (Pre-alarm).

Post-alarm images

Type the number of images to be recorded after detecting an alarm (Post-alarm).

Maximum alarm images

Displays the maximum number of images that can be recorded in the alarm buffer with the current image size and image quality.

Note

The number of Maximum alarm images differs depending on the Image size and Image quality settings on the Camera setting page.

Check the Maximum alarm images setting and set so that the total number of Pre-alarm images and Post-alarm images does not exceed the Maximum alarm images.

If you set both Pre-alarm images and Post-alarm images to **0**, only one image is recorded at the moment when an alarm is detected.

OK/Cancel

See “Buttons common to every setting page” on page 19.

Communicating Data via Serial Port

— Serial setting Page

When you click **Serial** on the Administrator menu, the Serial setting page appears.

Use this page to set up for the data communication via the serial interface. You can input data from a computer via the network to the camera, and output it to an external serial interface for controlling a peripheral device, or, vice versa, input data from a peripheral device to the camera via the external serial interface and output it to the computer via the network.

Perform the setting to match the peripheral device you connect to the camera.

Serial setting	
Standard	<input checked="" type="radio"/> RS232C <input type="radio"/> RS485
Mode	<input type="radio"/> HTTP <input checked="" type="radio"/> TCP <input type="radio"/> VISCA
TCP port No.	40000 (1024 to 65535)
Baud rate	9600 bps
Parity bit	none
Character length	8 bits
Stop bits	1 bits
<input type="button" value="OK"/> <input type="button" value="Cancel"/>	

Standard

Select the serial standard used to connect a peripheral device via the serial interface: **RS232C** or **RS485**.

Note

If **RS485** is selected on the Standard menu, the data communication is semi-duplex. Connect a peripheral device supporting semi-duplex communication.

Mode

Select the port through which you send and receive data via the network: **HTTP** (HTTP Generic Driver) or **TCP** (TCP Generic Driver), or select if the camera is controlled using the VISCA protocol.

HTTP: When you select **HTTP**, you can realize data communication by creating an HTML program with CGI commands embedded in the computer.

For the CGI commands, consult your authorized Sony dealer.

TCP: When you select **TCP**, specify the TCP port number on the TCP Port No. menu, and you can send and receive data that is input to or output from the external serial communication port. You can check the connection to the camera using a DOS command “telnet [host name] [assigned port number]”.

VISCA: When you select **VISCA**, you can control the camera using the VISCA protocol.
For the command list of the VISCA protocol, consult your authorized Sony dealer.

Notes

- When you control the camera via the serial port using the VISCA protocol, match the communication settings with those on the connected controller.
- This camera does not support the daisy chain connection of VISCA devices. Connect the camera and the controller one for one.

TCP port No.

When you select **TCP** on the Mode menu, type the port number for the TCP port (TCP Generic Driver). Set a port number other than Well-Known port numbers (0 to 1023).

Baud rate

Select the communication baud rate for the peripheral device connected to the serial interface. You can select from among the following baud rates:
38400, 19200, 9600, 4800, 2400, 1200, 600, 300 (bps)

Parity bit

Select the parity bit for the peripheral device connected to the serial interface: **None, Odd** or **Even**.

Character length

Select the character length for the peripheral device connected to the serial interface: **7** or **8** (bits).

Stop bits

Select the stop bit for the peripheral device connected to the serial interface: **1** or **2** (bits).

OK/Cancel

See “Buttons common to every setting page” on page 19.

Setting the Schedule

— Schedule setting Page

When you click **Schedule** on the Administrator menu, the Schedule setting page appears.
Use this page to set up to six schedules used for the preset position function, Day/Night function, FTP client function, SMTP function, Alarm out 1 or 2 function and Image memory function.

Schedule setting	
Schedule No.	Time table (00:00 to 24:00)
No. 1	Start time: 00 H 00 M - End time: 24 H 00 M <input checked="" type="checkbox"/> Mon <input checked="" type="checkbox"/> Tue <input checked="" type="checkbox"/> Wed <input checked="" type="checkbox"/> Thu <input checked="" type="checkbox"/> Fri <input type="checkbox"/> Sat <input type="checkbox"/> Sun
No. 2	Start time: 00 H 00 M - End time: 24 H 00 M <input checked="" type="checkbox"/> Mon <input checked="" type="checkbox"/> Tue <input checked="" type="checkbox"/> Wed <input checked="" type="checkbox"/> Thu <input checked="" type="checkbox"/> Fri <input type="checkbox"/> Sat <input type="checkbox"/> Sun
No. 3	Start time: 00 H 00 M - End time: 24 H 00 M <input checked="" type="checkbox"/> Mon <input checked="" type="checkbox"/> Tue <input checked="" type="checkbox"/> Wed <input checked="" type="checkbox"/> Thu <input checked="" type="checkbox"/> Fri <input type="checkbox"/> Sat <input type="checkbox"/> Sun
No. 4	Start time: 00 H 00 M - End time: 24 H 00 M <input checked="" type="checkbox"/> Mon <input checked="" type="checkbox"/> Tue <input checked="" type="checkbox"/> Wed <input checked="" type="checkbox"/> Thu <input checked="" type="checkbox"/> Fri <input type="checkbox"/> Sat <input type="checkbox"/> Sun
No. 5	Start time: 00 H 00 M - End time: 24 H 00 M <input checked="" type="checkbox"/> Mon <input checked="" type="checkbox"/> Tue <input checked="" type="checkbox"/> Wed <input checked="" type="checkbox"/> Thu <input checked="" type="checkbox"/> Fri <input type="checkbox"/> Sat <input type="checkbox"/> Sun
No. 6	Start time: 00 H 00 M - End time: 24 H 00 M <input checked="" type="checkbox"/> Mon <input checked="" type="checkbox"/> Tue <input checked="" type="checkbox"/> Wed <input checked="" type="checkbox"/> Thu <input checked="" type="checkbox"/> Fri <input type="checkbox"/> Sat <input type="checkbox"/> Sun
<input type="button" value="OK"/> <input type="button" value="Cancel"/>	

Schedule No. 1 to Schedule No. 6

For each schedule, specify Start time (hour and minutes) and End time (hour and minutes), and check the days of the week that you want to activate the function.

OK/Cancel

See “Buttons common to every setting page” on page 19.

Setting the Activity Detection Function — Activity detection setting Page

When you click **Activity detection** on the Administrator menu, the Activity detection setting page appears. Use this page to set up for the activity detection to link various applications.



Sensitivity

Select the sensitivity of the activity detection from the drop-down list. You can select the sensitivity between **Level 1** and **Level 9**. **Level 9** is the maximum sensitivity.

Tip

The Sensitivity of the activity detection means a proportion of the changed area (pixels) to the whole activity detection area.

OK/Cancel

See “Buttons common to every setting page” on page 19.

Setting the Activity Detection Area

Set the activity detection working area as follows:

- 1 Determine the view angle of the camera at which you want to perform activity detection, using the pan, tilt and zoom.
- 2 Click **Activity detection** on the Administrator menu.
A still picture is captured and the Activity detection setting page appears.

- 3 Hold down the mouse left button and drag it diagonally.
The portion marked with a red frame determines the activity detection working area.
As the default setting, the whole area is set as the activity detection working area.

Note

Before using the activity detection, perform the operation test to confirm correct operation.

The activity detection may not operate correctly in the following cases:

- when the Stabilizer menu is set to **On** on the Camera setting page
- when the Day/Night function is activated on the Camera setting page
- while changing a setting on the Camera setting page
- when the Focus mode menu is set to **Auto** on the Camera setting page
- while zooming in
- when the object is dark
- when the camera is installed in an unstable place that causes vibration to the camera

Showing the Pop-up

— Pop-up setting Page

When you click **Pop-up** on the Administrator menu, the Pop-up setting page appears.

Use this page to set up for displaying a pop-up with your favorite message on the computers monitoring the camera image, or for displaying a pop-up automatically when there is an alarm input.

Pop-up setting		
Manual pop-up text		
Information from SNC-RZ30		Apply
Alarm pop-up text		
Display mode	<input checked="" type="radio"/> Administrator <input type="radio"/> All users	
Sensor1	<input type="radio"/> On <input checked="" type="radio"/> Off	Sensor1 Input
Sensor2	<input type="radio"/> On <input checked="" type="radio"/> Off	Sensor2 Input
Sensor3	<input type="radio"/> On <input checked="" type="radio"/> Off	Sensor3 Input
Activity detection	<input type="radio"/> On <input checked="" type="radio"/> Off	Activity Detection Input
		OK Cancel

Manual pop-up text

Type the text to be displayed on a pop-up between 1 and 64 characters.

Click **Apply** to display the pop-up on all the computers monitoring the camera.

Alarm pop-up text

Display mode

Select the computer on which you want to display a pop-up when an alarm is input.

Administrator: The pop-up is displayed only on the computer monitoring the camera image as the Administrator.

All users: The pop-up is displayed on all the computers monitoring the camera image.

Sensor 1/Sensor 2/Sensor 3/Activity detection

Select **On** to show a pop-up when an alarm occurs by the corresponding sensor. Select **Off** not to show it.

On each text box, type the text to be displayed on the pop-up between 1 and 64 characters.

OK/Cancel

See “Buttons common to every setting page” on page 19.

Using the Supplied Setup Program

To connect the camera to a network, you need to assign a new IP address to the camera when you installed the camera for the first time.

You can assign an IP address in two ways:

- Using the setup program stored in the supplied CD-ROM (see page 49)
- Using the ARP (Address Resolution Protocol) commands (see page 51)

This section explains how to assign an IP address to the camera using the supplied setup program and configure the network.

The setup program also allows the communication bandwidth setting and date and time setting.

Before starting, connect the camera to a computer or a local network, referring to “Assigning the IP Address to the Camera” in the supplied Installation Manual.

Assigning the IP Address Using the Setup Program

- 1 Insert the supplied CD-ROM disc into your CD-ROM drive.
- 2 Double-click the Setup folder in the CD-ROM drive.
- 3 Double-click Setup.exe.
- 4 Install the IP Setup Program to your computer following the wizard displayed.
If the Software License Agreement is displayed, read it carefully and accept the agreement to continue the installation.
- 5 Start the IP Setup Program.

The program detects the SNC-RZ30 cameras connected to the local network and lists them on the Network tab window.

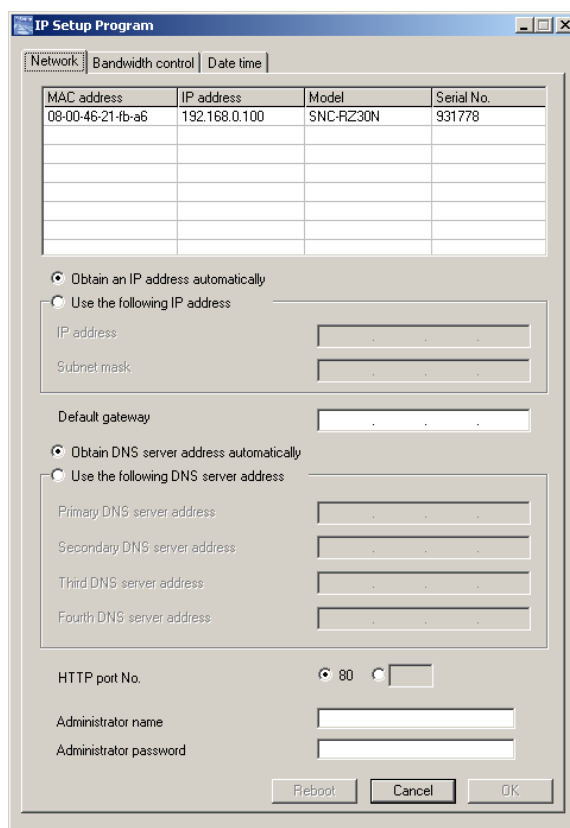

- 6 Click on the camera you want to assign a new IP address in the list.
The network settings for the selected camera are displayed.

- 7 Set the IP address.

To obtain the IP address automatically from a DHCP server:

Select **Obtain an IP address automatically**.

The IP address, Subnet mask and Default gateway are assigned automatically.

To specify the IP address manually:

Select **Use the following IP address**, and type the IP address, Subnet mask and Default gateway in each box.

- 8 Set the primary DNS server address and, if necessary, secondary DNS server address.

To obtain the DNS server addresses automatically:

Select **Obtain DNS server address automatically**.

To specify the DNS server addresses manually:
Select **Use the following DNS server address**, and type the Primary DNS server address and Secondary DNS server address in each box.

Note

The Third DNS server address and Fourth DNS server address are invalid for this camera.

- 9 Set the HTTP port number.
Normally select **80** for the HTTP port number. To use another port number, select the text box and type a port number between 1024 and 65535.
- 10 Type the Administrator name and Administrator password.
The default settings of both items are “admin.”
- 11 Confirm that all items are correctly set, then click **OK**.
If “Setting OK” is displayed, the IP address is correctly assigned.

Changing the Communication Bandwidth

- 1 Click the Bandwidth control tab to display the bandwidth setting window.
The current bandwidth is displayed in **Current bandwidth**.

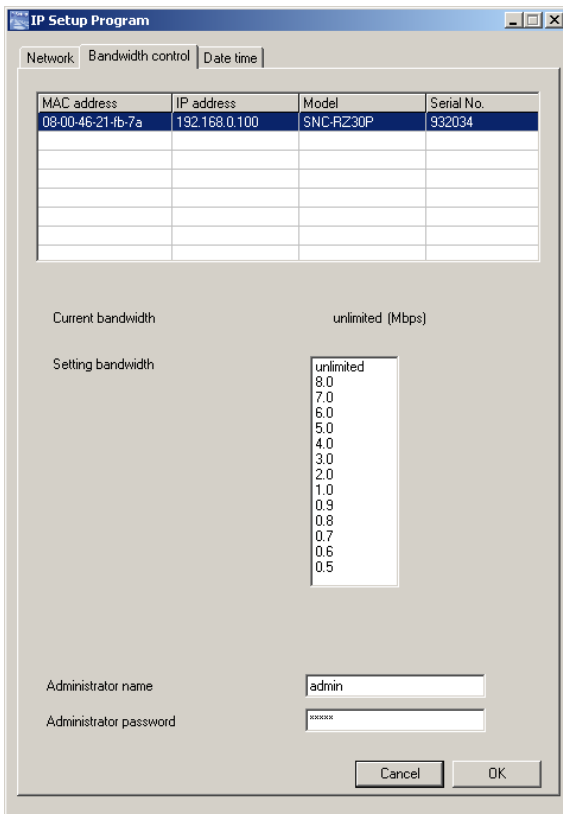

- 2 Click to select the desired bandwidth from the Setting bandwidth list box.
- 3 Type the Administrator name and Administrator password in each box.
- 4 Click **OK**.
If "Setting OK" is displayed, the bandwidth setting is completed.

Setting the Date and Time

You can set the date and time on the camera.

- 1 Click the Date time tab to display the date/time setting window.

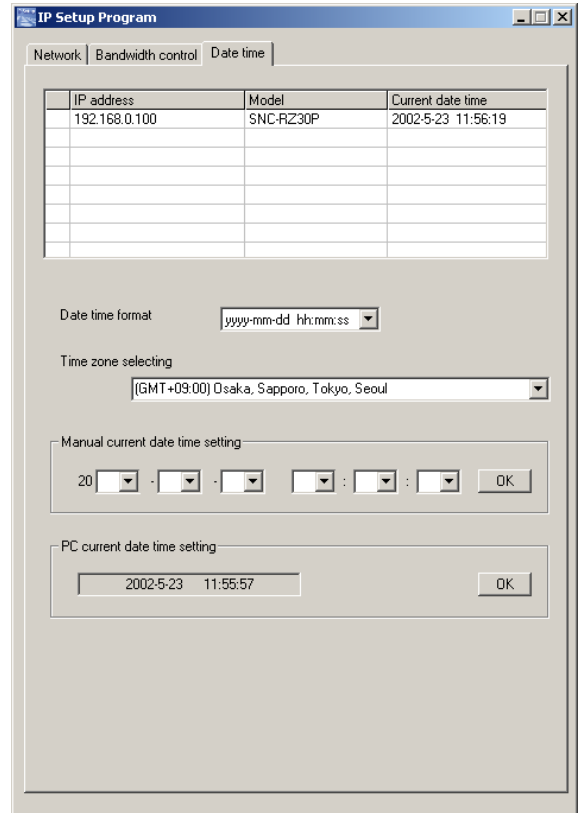

- 2 Click to select the camera you want to set the date and time for.
You can select multiple cameras and set the date and time simultaneously.
- 3 Select the date/time format from the Date time format drop-down list.
- 4 Select the area where the camera is installed from the Time zone selecting drop-down list.
- 5 Set the date and time.
You can set the date and time in two ways.

Manual setting

Set the current date and time on the Manual current date time setting boxes, and click **OK**. The setting boxes are for the year (lower two digits), month, date, hour, minutes and seconds from left to right.

Using the computer's date and time

The date and time set on the computer is displayed in the PC current date time setting box.

Click **OK** on the right to set the camera's date and time to the displayed computer's date and time.

Note

Due to the network properties, there may be a slight difference between the displayed computer's date and time and those set on the camera.

Rebooting the Camera

Click **Reboot** on the Network tab to reboot the camera. It will take about 10 to 20 seconds to reboot.

Assigning the IP Address to the Camera Using ARP Commands

This section explains how to assign an IP address to the camera using ARP (Address Resolution Protocol) commands without using the supplied setup program.

Note

Enter the ARP commands within 5 minutes after the power of the camera is turned on.

- 1 Open the DOS window on the computer.
- 2 Enter the IP address and the MAC address of the camera you want assign a new IP address to, using the following ARP commands.

```
arp -s <Camera's IP address> <Camera's MAC address>  
ping -t <Camera's IP address>
```

Example:

```
arp -s 192.168.0.100 08-00-46-21-00-00  
ping -t 192.168.0.100
```

- 3 When the following line is displayed on the DOS window, hold down **Ctrl** and press **C**.

```
Reply from 192.168.0.100:bytes=32 time...
```

You will normally receive the reply after about 5 repetitions of "Request time out."

Note

- If you do not receive the reply, check the following:
- Did you enter the ARP commands within 5 minutes after the camera was turned on?
If not, turn off the camera and restart the operation.
 - Is the NETWORK indicator on the camera flashing?
If the indicator goes off, the network connection has a problem. Connect the network correctly.
 - Did you enter the IP address previously used for another device?
Assign a new IP address to the camera.
 - Do the computer and the camera have the same network address?
If not, set the same network address on the computer and the camera.

Using the SNMP

This unit supports SNMP (Simple Network Management Protocol). You can read MIB-2 objects and write some MIB-2 objects using software such as SNMP manager software. This unit also supports the coldStart trap which occurs when the power is turned on or the unit restarts, and the Authentication failure trap which informs of an illegal access using SNMP. Using CGI commands, you can set community name and access limitation, reading/writing right, host to send traps, and some MIB-2 objects. To allow these settings, you need Level 4 authentication (the right to open the setting pages).

1. Inquiry Commands

You can check the SNMP Agent settings using the following CGI commands.

```
<Method>
  GET, POST
<Command>
  "http://ip_adr/snmpdconf/inquiry.cgi?inqjs=snmp
  (JavaScript parameter format)
  http://ip_adr/snmpdconf/inquiry.cgi?inq=snmp
  (standard format)
```

With the above inquiry, you can obtain the following setting information. The following explains the setting information using the inqjs=snmp (JavaScript parameter) format.

```
var sysDescr="\SONY Network Camera SNC-
RZ30\" ...①
var sysObjectIP="1.3.6.1.4.1.122.8501 ...②
var sysLocation="\ ...③
var sysContact="\ ...④
var sysName="\ ...⑤
var snmpEnableAuthenTraps="1" ...⑥
var community="public,0.0.0.0,read,1" ...⑦
var community="private,192.168.0.101,write,2" ...⑧
var trap="public,192.168.0.101.1" ...⑨
```

- ① describes the instance of “mib-2.system.sysDescr.0”. You cannot change this parameter.
- ② describes the instance of “mib-2.system.sysObjectID.0”. You cannot change this parameter.
- ③ describes the instance of “mib-2.system.sysLocation.0”. This field is used to describe the information on the location of this camera. Nothing is set at the factory.

- ④ describes the instance of “mib-2.system.sysContact.0”. This field is used to describe the information on the administrator of this camera. Nothing is set at the factory.
- ⑤ describes the instance of “mib-2.system.sysName.0”. This field is used to describe the administration node of this camera. Nothing is set at the factory.
- ⑥ describes the instance of “mib-2.snmpEnableAuthenTraps.0”. This example shows when “1” (enable) is set. With this setting, a trap occurs when there is an Authentication failure. When “2” (disable) is set, no Authentication failure trap occurs.
- ⑦ describes the community name and the reading/writing attributes. This example shows the identification number “ID=1”, the community name public, and enables read from any IP address (0.0.0.0).
- ⑧ describes the community name and the reading/writing attributes, similarly to ⑦. This example shows the identification number ID=2, the community name “private”, and enables “read/write” by the SNMP request packet from the host “192.168.0.101”.
- ⑨ describes the host name to send a trap. This example shows the identification number “ID=1”, the community name “public”, and enables sending of traps to the host having the IP address “192.168.0.101”.

2. Setting Commands

The unit supports the following setting commands of SNMP.

```
<Method>
  GET, POST
<Command>
  http://ip_adr/snmpdconf/snmpdconf.cgi?
  <parameter>=<value>&<parameter>=...&...
```

First, perform the settings of the following parameters.

- 1) sysLocation=<string>
Set the instance of “mib-2.system.sysLocation.0” in the <string> position. The maximum length of <string> is 255 characters.
- 2) sysContact=<string>
Set the instance of “mib-2.system.sysContact.0” in

the <string> position. The maximum length of <string> is 255 characters.

- 3) sysName=<string>
Set the instance of “mib-2.system.sysName.0” in the <string> position. The maximum length of <string> is 255 characters.
- 4) enaAuthTraps=<value>
Set the instance value of “mib-2.snmp.snmpEnableAuthenTraps.0” in the <string> position. Type “1” (enable) or “2” (disable) in the <value> position.
- 5) community=<ID>,<rwAttr>,<communityName>,<IpAddressString>
Set the community name and the reading/writing attributes. <ID> describes the setting identification number (1 to 8), <rwAttr> describes a character representing the reading/writing attribute (“r”, “R”, “w or “W”), <communityName> describes the community name to be set, and <IpAddressString> describes the IP address of the host you allow the access (0.0.0.0 for any host).
Example: To allow reading/writing any host in the “private” community and having the ID number “2”.
community=2,w,private,0.0.0.0
- 6) trap=<ID>,<communityName>,<IpAddressString>
Set the host you want to send traps to. <ID> describes the setting identification number (1 to 8), <communityName> describes the community name to send traps to, and <IpAddressString> describes the IP address of the host to send traps to.
Example: To specify the destination of traps as the private community and the ID number “1”.
rap=1,public,196.168.0.101
- 7) delcommunity=<ID>
This parameter is used to delete the previous community setting. <ID> describes the community setting identification number (1 to 8).
- 8) deltrap=<ID>
This parameter is used to delete the previous setting of the host to send traps to. <ID> describes the trap setting identification number (1 to 8).

When you have finished changing the SNMP setting information, check the changed settings using an inquiry command. If the changed settings are OK, restart the SNMP using the following CGI command. Be careful

that by entering the command, the camera enters the restart mode.

SNMP restart command

<Method>

GET, POST

<Command>

http://ip_adr/snmpdconf/snmpdconf.cgi?

snmpd=restart