



### features . . . . .

- **Panel Space:** 4U or 7.00" [178]
- **Overall Height:** 9.25" [235]
- **Overall Depth:** 6.00" [152]
- **Usable Depth:** 5.97" [152]
- **Overall Width:** 19.30" [490]  
(allow 21" for wing nuts)
- **Description:** Ideal platform for installing voice and data equipment, patch panels, routers, hubs, and network switches to create a structured, organized cabling system.
- **Construction:** Certified U.S. steel, 16-gauge frame with black semi-gloss powder epoxy finish.
- **Front:** Hinged panel-mounting frame pivots to 90 degrees with an absolute stop to provide access to equipment for punch-down interconnects while in the fully open position.
- **Rear:** The rear is open to allow positioning over and around existing wall obstructions. Mounts on standard 16" centers.
- **Sides:** Solid 16-gauge steel sides.
- **Bottom:** Open access.
- **Top:** Open access.
- **Cable Management:** Integral tie loop points on bottom and rear.
- **Rack Rails – 4U (fixed position):** One pair of 11-gauge steel 10-32 threaded rails on E.I.A. spacing. Black finish.
- **Hardware:** Black pilot point screws with captive washers for quick installation.
- **Compliance:** EIA/TIA compliant. RoHS compliant.
- **Load Capacity:** 30 lbs. [13 kg]



### a&e specifications . . . . .

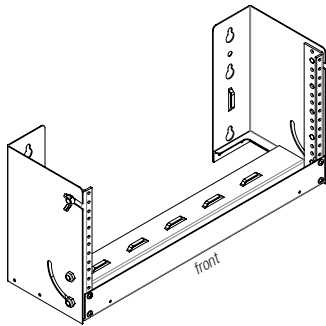

The EIA/TIA compliant 19" wall-mount rack shall be Lowell #PFR-46 with overall dimensions of 9.25"H x 6.00"D x 19.30"W; usable height of 4 rack units, and usable depth of 5.97". The rack shall mount on standard 16" centers. Rack construction shall be certified U.S. steel with 16-gauge frame and black semi-gloss powder epoxy finish. It shall have an open back to fit around wall obstructions, an open access base, and integral tie loop points. Open front shall include one pair fixed-position 4U rails tapped 10-32. The front panel-mounting frame shall pivot down to an absolute stop at 90 degrees, providing access to equipment for punch-down interconnects while in the fully open position. The rack shall be manufactured in the U.S.A. with load capacity of 30 lbs.

### PFR series summary

Model No.	Rack Units	Overall Depth	Usable Depth	Overall Height	Overall Width*	Front Frame Pivot-Down	Load Capacity	Fixed Rails
▶ PFR-46	4 U	6.00 [152]	5.97 [152]	9.25 [235]	19.30 [490]	90 degrees	30 lbs [13 kg]	1 pr
PFR-66	6 U	6.00 [152]	5.97 [152]	12.75 [324]	19.30 [490]	90 degrees	30 lbs [13 kg]	1 pr
PFR-612	6 U	12.00 [305]	11.97 [304]	12.75 [324]	19.30 [490]	90 degrees	40 lbs [18 kg]	1 pr
PFR-812	8 U	12.00 [305]	11.97 [304]	16.25 [413]	19.30 [490]	90 degrees	60 lbs [27 kg]	1 pr
PFR-818	8 U	18.00 [457]	17.97 [456]	16.25 [413]	19.30 [490]	90 degrees	60 lbs [27 kg]	1 pr

\*Allow 21" width for wing nuts.  
Rack dimensions (rounded) – inches and [mm]; 1U = 1.75"

