

Engineered for electronics stored in credenza style cabinetry, or underneath counters or desks, the LCR open frame rack is precision formed and fully welded to provide rugged support, torsional rigidity and labor-saving field installation.

FEATURES

- **Panel Space:** 8U or 14.00" [356]
- **Overall Height:** 14.94" [379]
- **Overall Depth:** 16.00" [406]
- **Overall Width:** 19.25" [489]
- **Construction:** Welded 16-gauge certified U.S. steel frame with 11-gauge corner post rails. Black semi-gloss powder epoxy finish. Ships ready to install.
- **Installation:** Rack corners feature 0.25" diameter holes and slots for anchoring or positioning. Base includes grounding studs and provisions for anchor bolts (not included).
- **Mounting Rails:** Corner post rails, with mounting holes tapped 10-32, are punched on sides to facilitate clean wire tie-off and bundling. Black finish.
- **Cable Management:** Side openings offer convenient cable and wire lacing opportunities.
- **Hardware:** Includes panel mounting hardware.
- **Compliance:** EIA/TIA compliant. RoHS compliant.
- **Load Capacity:** 250 lbs.
- **Optional:**
 - Runner Kit: Set of two plastic glides to protect cabinet surface. Adds 0.25" to overall height. (LCR-16RK)

A&E SPECIFICATIONS

The EIA/TIA compliant open frame rack shall be Lowell LCR-816, which shall be built to EIA standards for mounting electronics. Dimensions shall be 14.94"H x 16.00"D x 19.25"W with 8U panel space. The rack shall be fully welded certified U.S. steel construction with 16-gauge top and bottom, 11-gauge corner post rails tapped 10-32, and multiple openings for cable and wire management. Finish shall be black semi-gloss powder epoxy paint.

Optional

- The rack shall include protective runner kit LCR-16RK to help protect cabinet surface.

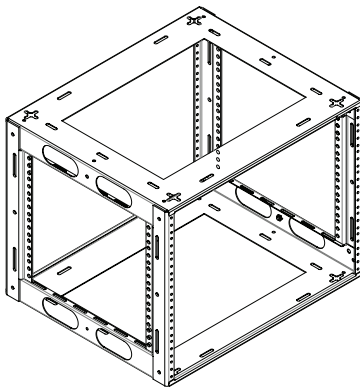

LCR SERIES SUMMARY

Model No.	Panel Space	Overall Depth	Overall Height	Usable Height	Overall Width	Corner Post Mtg Rails	Load Capacity
LCR-816	8 U	16.00 [406]	14.94 [379]	14.00 [356]	19.25 [489]	4	250 lbs.
LCR-1016	10 U	16.00 [406]	18.44 [468]	17.50 [445]	19.25 [489]	4	250 lbs.
LCR-1216	12 U	16.00 [406]	21.94 [557]	21.00 [533]	19.25 [489]	4	250 lbs.
LCR-1416	14 U	16.00 [406]	25.44 [646]	24.50 [622]	19.25 [489]	4	250 lbs.
LCR-818	8 U	18.00 [457]	14.94 [379]	14.00 [356]	19.25 [489]	4	250 lbs.
LCR-1018	10 U	18.00 [457]	18.44 [468]	17.50 [445]	19.25 [489]	4	250 lbs.
LCR-1218	12 U	18.00 [457]	21.94 [557]	21.00 [533]	19.25 [489]	4	250 lbs.
LCR-1418	14 U	18.00 [457]	25.44 [646]	24.50 [622]	19.25 [489]	4	250 lbs.

Rack dimensions (rounded) – inches and [mm]; 1U = 1.75"



TECHNICAL DRAWINGS

Dimensions are inches and [mm] unless stated otherwise.

