

Wall rack features welded steel backbox and front mounting section. Ships in 2 cartons so backbox can be field-installed while front is loaded at the shop.



FEATURES

- **Panel Space:** 16U or 28.00" [711]
- **Overall Height:** 34.13" [867]
- **Overall Depth:** 19.05" [484]
- **Usable Depth:** 16.00" [406], allowing partial extension of equipment into backbox
- **Overall Width:** 23.06" [586]
- **Construction:** Welded 16-gauge certified U.S. steel. Black wrinkle powder epoxy finish.
- **Backbox:**
 - 5.80"D with keyhole mounting slots on 16" centers
 - 10"x10" opening accommodates electrical pull box
 - 1/4-20 ground stud
 - Embossed dimples on back plane for installation of board-mounted accessories
 - Top and bottom have a laser-cut knockout panel with combination EKO's for conduit (1/2"–3/4" and 1"–1-1/2") and KO's for wireless antennae (1/2").
 - Side locks (2) are keyed differently than optional door.
- **Front Mounting Section:**
 - 13.06"D, welded sides, fully gusseted corners, triple formed (side-to-bottom, side-to-top) wrap design mounts to backbox from inside with 2 heavy duty (self seating, positive locking) spring-loaded L-pins (move pins to change swing orientation). Strength equivalent to 3/16" steel. Front and side vents. Beveled front corners. Roller closure keeps front closed without mandatory locking.
 - Top/bottom KO's for wireless antennae and integral rails on E.I.A. spacing for mounting or lacing.
 - Rack Rails: 1 pair (16U) 11-gauge steel rails with black finish, 10-32 threaded holes and numbered RU increments. Recessed 0.625"
- **Installation:** Minimum clearance to allow mounting section to swing open 90 degrees is 13.26" (+1" for optional door). Mounting section can swing open more than 90 degrees if room is provided.
- **Hardware:** Black pilot point screws with captive washers for quick installation.
- **Compliance:** EIA/TIA compliant. RoHS compliant. UL 2416 Listed in U.S. and Canada.
- **UL Listed Load Capacity:** 200 lbs.
- **Optional:**
 - Surface-mount front door: solid steel, fully-vented steel, or smoked plexiglass (LFD-16, LFD-16FV, LFD-16P)
 - Additional pair of 16U mounting rails (RRD-16)



LWR SERIES SUMMARY

Model No.	Rack Units	Overall Depth	Usable Depth*	Overall Height	Usable Height	Overall Width	Load Capacity	Front Corners	Adjustable Rails
LWR-719	7 U	19.05 [484]	16.00 [406]	18.38 [467]	12.25 [311]	23.06 [586]	125 lbs	Beveled	1 pr
LWR-1019	10 U	19.05 [484]	16.00 [406]	23.63 [600]	17.50 [445]	23.06 [586]	150 lbs	Beveled	1 pr
LWR-1219	12 U	19.05 [484]	16.00 [406]	27.13 [689]	21.00 [533]	23.06 [586]	150 lbs	Beveled	1 pr
LWR-1619	16 U	19.05 [484]	16.00 [406]	34.13 [867]	28.00 [711]	23.06 [586]	200 lbs	Beveled	1 pr
LWR-2119	21 U	19.05 [484]	16.00 [406]	42.88 [1089]	36.75 [933]	23.06 [586]	250 lbs	Beveled	1 pr
LWR-2419	24 U	19.05 [484]	16.00 [406]	48.13 [1223]	42.00 [1067]	23.06 [586]	300 lbs	Beveled	1 pr
LWR-3519	35 U	19.05 [484]	16.00 [406]	67.38 [1711]	61.25 [1556]	23.06 [586]	300 lbs	Beveled	1 pr
LWR-723	7 U	23.05 [585]	20.00 [508]	18.38 [467]	12.25 [311]	23.06 [586]	125 lbs	Beveled	1 pr
LWR-1023	10 U	23.05 [585]	20.00 [508]	23.63 [600]	17.50 [445]	23.06 [586]	150 lbs	Beveled	1 pr
LWR-1223	12 U	23.05 [585]	20.00 [508]	27.13 [689]	21.00 [533]	23.06 [586]	150 lbs	Beveled	1 pr
LWR-1623	16 U	23.05 [585]	20.00 [508]	34.13 [867]	28.00 [711]	23.06 [586]	200 lbs	Beveled	1 pr
LWR-2123	21 U	23.05 [585]	20.00 [508]	42.88 [1089]	36.75 [933]	23.06 [586]	250 lbs	Beveled	1 pr
LWR-2423	24 U	23.05 [585]	20.00 [508]	48.13 [1223]	42.00 [1067]	23.06 [586]	300 lbs	Beveled	1 pr
LWR-3523	35 U	23.05 [585]	20.00 [508]	67.38 [1711]	61.25 [1556]	23.06 [586]	300 lbs	Beveled	1 pr
LWR-1228	12 U	28.05 [712]	25.00 [635]	27.13 [689]	21.00 [533]	23.06 [586]	200 lbs	Squared	1 pr
LWR-1628	16 U	28.05 [712]	25.00 [635]	34.13 [867]	28.00 [711]	23.06 [586]	250 lbs	Squared	1 pr
LWR-2428	24 U	28.05 [712]	25.00 [635]	48.13 [1223]	42.00 [1067]	23.06 [586]	300 lbs	Squared	1 pr
LWR-1232	12 U	31.87 [809]	29.00 [737]	27.13 [689]	21.00 [533]	23.06 [586]	200 lbs	Squared	1 pr
LWR-1632	16 U	31.87 [809]	29.00 [737]	34.13 [867]	28.00 [711]	23.06 [586]	250 lbs	Squared	1 pr
LWR-2432	24 U	31.87 [809]	29.00 [737]	48.13 [1223]	42.00 [1067]	23.06 [586]	300 lbs	Squared	1 pr

*Usable Depth allows partial extension of equipment into backbox. Rack dimensions (rounded) – inches and [mm]; 1U = 1.75"



TECHNICAL DRAWINGS

Dimensions are inches and [mm] unless stated otherwise.

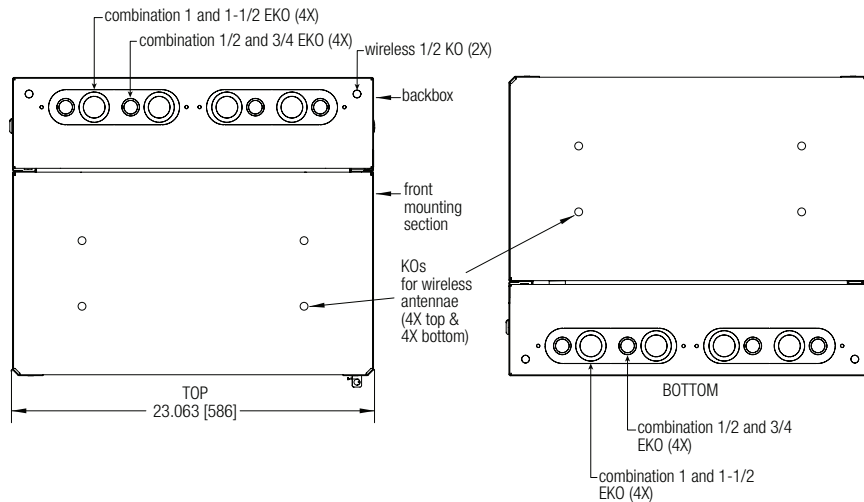
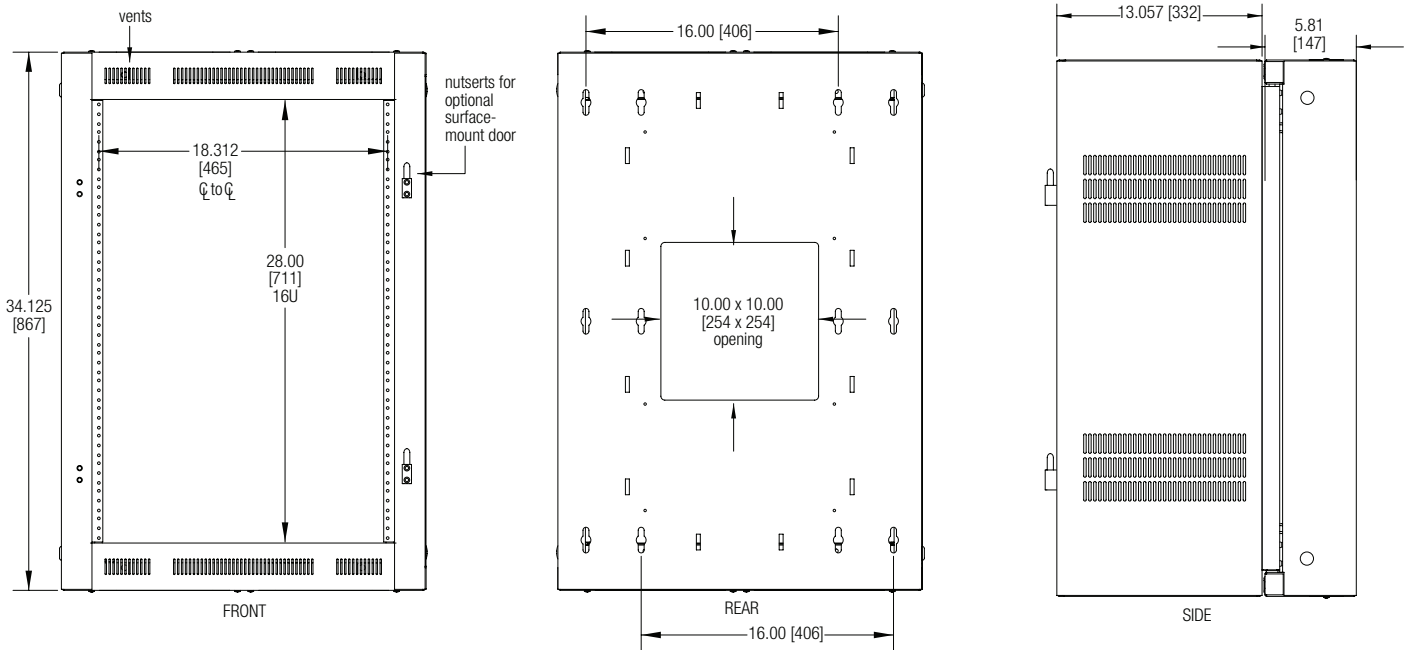

CORNER INSTALL DETAIL (19"D rack)

- Minimum clearance to open 90 degrees = 13.26"
- Allow additional 1" for optional door depth
- Allow sufficient clearance to access side locks (5")

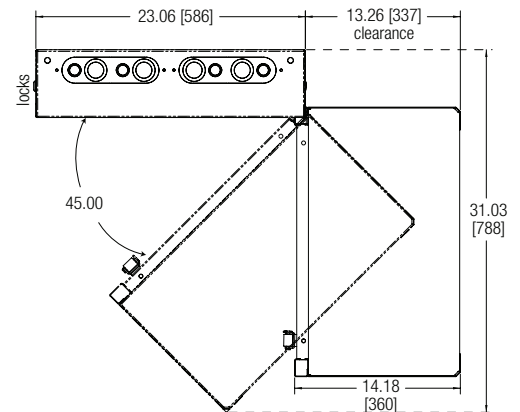

A&E SPECIFICATIONS

The E.I.A. compliant, UL2416 listed, welded sectional wall rack shall be Lowell LWR-1619, which shall consist of a backbox and mounting section made in the U.S.A. from 16 gauge certified U.S. steel. Overall measurements shall be 34.13"H x 19.05"D x 23.06"W, providing 16U panel space. The mounting section shall be 13.06"D with triple formed side-to-bottom, side-to-top wrapped construction to achieve strength equivalent to 3/16" thick steel. It shall feature side vents, one pair adjustable mounting rails tapped 10-32, four knockouts for antennas (top and bottom), and integral rails on E.I.A. spacing (top and bottom). The mounting section shall attach to the backbox on the inside with two heavy duty, spring-loaded L-pins (self seating, positive locking), which can be attached on either side to alter swing orientation. The backbox shall be

5.80"D with keyhole mounting slots on 16" centers, a 10"x 10" rear opening, embossed dimples and lacing points on the back plane, knockout panels with combination knockouts (1/2"-3/4", and 1-1-1/2"), and two keyed side locks. The rack shall have a black wrinkle powder epoxy finish.

Optional

- The rack shall include a _____ (solid steel, fully-vented steel, smoked plexiglass) surface-mount front door _____ (Lowell LFD-16, LFD-16FV, LFD-16P).
- The rack shall include an additional pair of mounting rails, Lowell RRD-16.

