

## Thunder-KS

Compact, multi-tasking subwoofers

Thank you for choosing this K-array product!

To ensure proper operation, please carefully read this quick guide.

Download the owner's manual and safety instruction from the official K-array website at [www.k-array.com](http://www.k-array.com):



download user guide

Before using the product please carefully read the owner's manual and safety instruction.

After reading this quick guide, be sure to keep it for future reference.

Should you have any questions about your new device please contact K-array customer service at [support@k-array.com](mailto:support@k-array.com) or contact the [official K-array distributor](#) in your country.

Our Thunder-KS line gives you all the boom with bass you need for installation and live applications. With both passive and active models in various sizes starting from 12" to 21" and dual 18", the Thunder-KS line is a high performance sub-bass system featuring a woofer with magnet structure and suspension engineered for maximum linear excursion.

Pocket handles and a M20 thread mount position for attaching top speakers make the subwoofers convenient to use and ideal for applications in theaters, concert halls, parties and restaurant installations.

More than just powered subwoofers, our active models depart from traditional subs in that their "smart" design puts electronics as the central component, transforming the mid-low frequency loudspeaker into a proper tool for the management and processing of the audio signal.

Carefully inspect the shipping carton, then examine and test your new device. If you find any damage, immediately notify the shipping company. Check that the following parts are supplied with the product:

- 1x Subwoofer unit: model and version shall be one from the following list:
  - a. Thunder-KS1 I
  - b. Thunder-KS1P I
  - c. Thunder-KS2 I
  - d. Thunder-KS1P I
  - e. Thunder-KS3 I
  - f. Thunder-KS3P I
  - g. Thunder-KS4 I
  - h. Thunder-KS4P I
- 1x This quick guide
- 1x Power cord in self powered models packages only (i.e. KS1 I, KS2 I, KS3 I, KS4 I).

The Thunder-KS self powered subwoofers implement a 4-channel power amplifier module with built-in DSP that can be managed and controlled via the dedicated K-array Connect app or the K-framework3 software.

In order to remote control any Thunder-KS active unit download the K-array Connect app:



### Connectivity Reset

Keep pressed the RESET button for 10 to 15 seconds in order to:

- Revert the wired IP addressing to DHCP;
- Activate the built-in Wi-Fi and reset the wireless parameters to the default SSID name and password (see User Guide "K-array Connect Mobile App" for details).

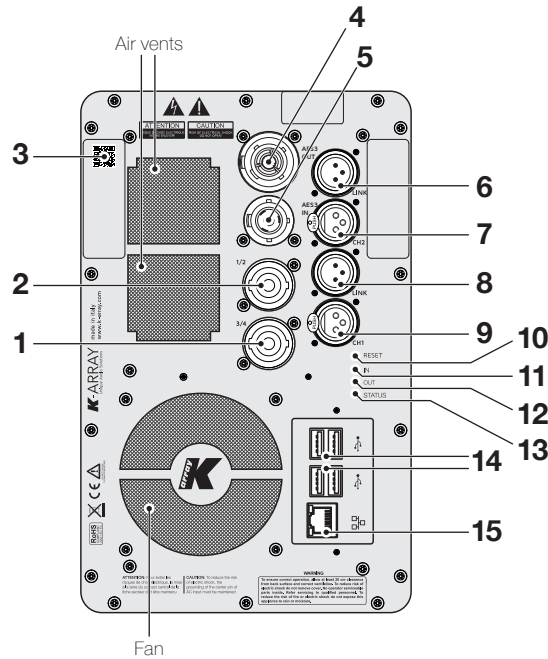

### Active Subwoofer Rear Panel

1. SpeakON NL4 speaker output channels 3 & 4
2. SpeakON NL4 speaker output channels 1 & 2
3. QR Code for the K-array Connect app remote connection
4. PowerCon TRUE link (AC mains in)
5. PowerCon TRUE inlet (AC mains in)
6. XLR-M channel 2 balanced line output or channels 3 & 4 AES3 output (user selectable via K-array Connect app)
7. XLR-F channel 2 balanced line input or channels 3 & 4 AES3 input (user selectable via K-array Connect app)
8. XLR-M channel 1 balanced line output
9. XLR-F channel 1 balanced line input
10. Reset button
11. Input signal LED monitor
12. Output signal LED monitor
13. System status LED
14. USB ports
15. RJ45 Ethernet port

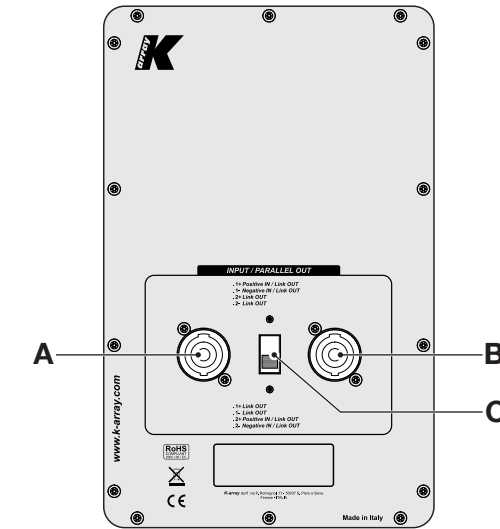

### Passive Subwoofer Rear Panel

- A. SpeakON NL4
- B. SpeakON NL4
- C. Terminals switch: swap the internal loudspeaker terminals assignment.

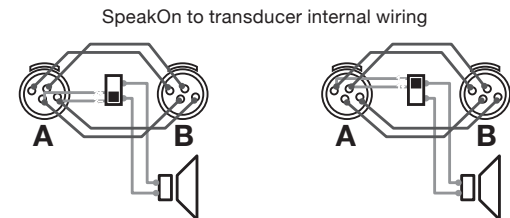

Sub on +2-2 [DEFAULT]

Sub on +1-1

## AC mains supply

On self powered Thunder-KS subwoofers, the AC Main connection is made via the provided power cord: insert the powerCon TRUE flying connector into the inlet and then rotate it clockwise. Once properly plugged and powered, the system status LED lights on.

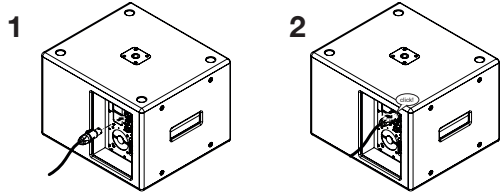

## K-array Connect Mobile App

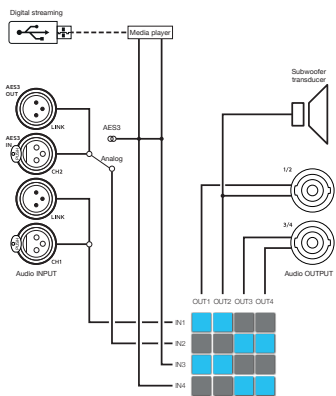
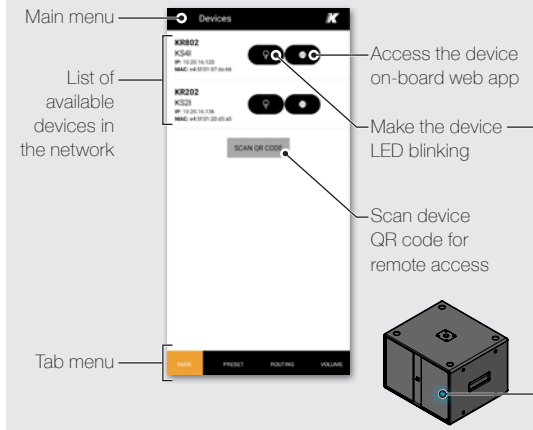

Default routing diagram.

## Getting Started

According to the version and model, follow these steps to make the system operating:

### Active Subwoofer (KS1I, KS2I, KS3I, KS4I)

1. Connect the input and output signal cables according to the configuration you want to achieve (see User Guide "Wiring").
2. Connect the power cord to an AC mains socket outlet and to the powerCon TRUE connector on the Thunder-KS rear panel: the Thunder-KS switches on when the powerCon TRUE connector is locked and electricity flows from the AC mains.
3. Hold your mobile device (smartphone or tablet):
  - a. ensure the Wi-Fi connectivity is on;
  - b. in Android based systems the app looks for any Wi-Fi network whose SSID name starts with "K-array"; swipe down to force refresh the list of available networks;
  - c. if the list of available devices is empty touch the SCAN QR CODE button and use the mobile device camera to frame the QR code at the top left corner of the Thunder-KS rear panel: this provides the mobile device to connect to the Thunder-KS Wi-Fi hotspot;
  - d. enter the password to connect to Thunder-KS active subwoofer (see User Guide "Connection and Discovery" for details).
4. In the K-array Connect app bottom menu, select PRESET and touch the compass button for setting the loudspeaker configuration (see User Guide "Output configuration"). Carefully check that the presets match the actual configuration of passive subwoofer and top speakers connected to the Thunder-KS rear speakON connectors.
5. Set the signal routing from the input channels to the output channels in the ROUTING menu (see User Guide "Signal Routing").
6. Check the signal volume in the VOLUME tab (see User Guide "Volume").
7. Enjoy K-array sound!

### Passive Subwoofer (KS1PI, KS2PI, KS3PI, KS4PI)

- A. Connect a proper speaker cable to the SpeakON connector on the Thunder-KS rear panel (see User Guide "Wiring").
- A. Connect the other side of the speaker cable to a power amplifier or to a Thunder-KS active subwoofer.
- B. On the active driving unit load the proper device preset according to the Thunder-KS passive subwoofer model (see User Guide "Output configuration").

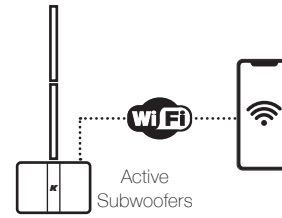

## Connection to a single Thunder-KS

1. Ensure the Wi-Fi of the mobile device is on.
2. Launch the K-array Connect app.
  - a. In Android based systems the app looks for any Wi-Fi network whose SSID name starts with "K-array"; swipe down to force refresh the list of available networks.
  - b. Touch the device name to establish a connection and insert the password (see below).
3. If the list of available devices is empty touch the SCAN QR CODE button and use the mobile device camera to frame the QR code at the top left corner of the Thunder-KS rear panel: this provides the mobile device to connect to the Thunder-KS Wi-Fi network.
4. Enter the password to connect to Thunder-KS active subwoofer. If not modified, the default password is the device serial number, e.g. K142AN0006 (case sensitive).
5. The K-array Connect app connects directly to the Thunder-KS active subwoofer.

## Connection to a network of Thunder-KS

The Thunder-KS active subwoofers feature an RJ45 Ethernet port on the rear panel that allows to connect the loudspeakers to a local area network (LAN), in order to ease the remote control.

The Thunder-KS implement the zeroconf network technologies, allowing to direct connect the active subwoofers to a PC via an Ethernet CAT5 cable, as well as including the devices into a network without any user configuration.



If a DHCP service is available, it will assign an IP address to each Thunder-KS. If a DHCP service is not available, each Thunder-KS active subwoofer will self assign an IP address in the range 169.254.0.0/16 (auto-IP).

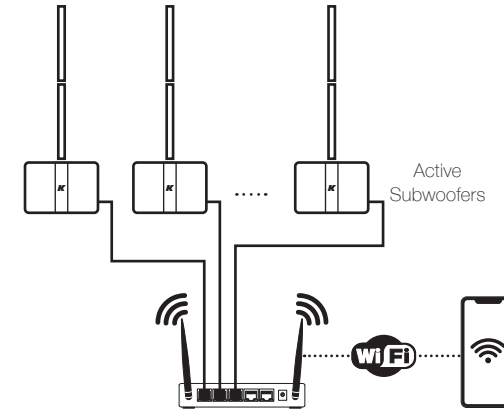

The simplest local network of Thunder-KS active subwoofers requires the implementation of an Ethernet switch. When an access point is available, the network of Thunder-KS active subwoofers can be easily managed with the K-array Connect mobile app over the LAN.

- A. Connect each Thunder-KS active subwoofer to a Wi-Fi access point with built-in Ethernet switch: use Ethernet Cat5 or Cat6 cables.
- B. Set the access point Wi-Fi network SSID and parameters.
- C. Ensure the Wi-Fi of the mobile device is on.
- D. Connect the mobile device to the access point Wi-Fi network.
- E. Launch the K-array Connect app: the app looks for any device in the network whose name starts with "K-array" and tries to establish a connection.
- F. If the list of available devices is empty swipe down to force refresh the list of available devices.

## On-Board Web App

The on-board web interface is a further user interface embedded on the built-in DSP that allows to manage the system features over a network. Once the IP address of a Thunder-KS active subwoofer is set and known, it is possible to access the built-in DSP features over a LAN with a web browser (Google Chrome is recommended).

Type the Thunder-KS active subwoofer IP address in the address field of the web browser (e.g. 10.20.16.171); the Thunder-KS will push the web interface for a direct access to its DSP features.

The K-array Connect mobile app offers a shortcut to access the on-board web interface.