

# TORUS

Constant Curvature Array

## User Guide



TORUS



# Contents

## Introduction

TORUS..... 4

Important Safety Instructions..... 5

Unpacking the Units..... 5

## System Overview

TORUS..... 6

Mechanical Design..... 6

Acoustic Design..... 7

Landscape Deployment..... 7

Portrait Deployment..... 8

Changing Horn Dispersion..... 8

## Accessories

T12POLERIG..... 9

T12GRID..... 9

SBAR..... 9

T12HRIG..... 9

T12TRIG..... 10

T12PB..... 10

T12GSRIG..... 10

## Recommended Subwoofer

SXCF118..... 11

## Amplification

iKON Amplifiers..... 12

## DISPLAY 3.0

Overview..... 13

## VU-NET 2.2

Overview..... 16

## Connections

Overview..... 21

**Rigging**

Overview.....22

T12GRID.....22

Inclinometer Assembly.....23

Flying the Array.....25

T12HRIG.....30

T12TRIG.....34

T12PB.....39

T12POLERIG.....42

SBAR.....44

**Essential Maintenance**

Replacing the LF Driver.....46

Replacing the High Frequency Diaphragms.....48

Remove the 6 rubber bungs from the horn flare.....48

Remove the socket cap fasteners from the horn to remove the compression driver. ....49

Remove the socket cap fasteners from the backplate to replace the diaphragm.....49

**Specifications**

T1215 and T1230.....50

**Technical Drawings**

T1215.....51

T1230.....52

**Warranty**

Warranty Statement.....53

## Introduction

### TORUS

For applications that typically require a throw between 15-30m, a full-blown line array is not always practical, optimal or affordable. Conversely, a point source solution may not be sufficient in coverage and SPL. TORUS is a constant curvature array, designed to fill that gap perfectly, combining optimised coverage, SPL and cost efficiency.

T1215 offers a narrow vertical pattern of 15° with a flexible horizontal pattern that can be manually adjusted between 90°, 60° or 75° (Asymmetrical) via the Dynamic Horn Flare™.

T1230 offers a vertical pattern of 30° with a flexible horizontal pattern that can be manually adjusted between 90°, 60° or 75° (Asymmetrical) via the Dynamic Horn Flare™.



## Important Safety Instructions

Please read these instructions and retain for future reference. Heed all warnings and follow all instructions.

- No naked flame sources such as lighted candles should be placed on the apparatus
- Do not block any ventilation openings
- Install in accordance with the Martin Audio instructions
- Do not install near any heat sources such as radiators, heat registers, stoves or other such apparatus that produce heat
- Do not defeat the safety purpose of the grounding-type plug. A grounding plug has two blades and a third grounding prong. The third prong is provided for your safety. If the provided plug does not fit your outlet consult an electrician for replacement of the obsolete outlet.
- Protect the power cable from being walked on or pinched particularly at plugs, convenience receptacles, and the point where they exit from the apparatus
- This equipment must be earthed
- Only use attachments / accessories specified by Martin Audio
- Use only with wheelboard and rigging hardware specified by Martin Audio. When moving using supplied wheelboards, caution should be used to avoid injury from the cabinet tipping over
- Unplug this apparatus during lightning storms or when unused for long periods of time
- No user serviceable parts inside, refer servicing to qualified service personnel. Servicing is required when the apparatus has been damaged in any way such as power supply cord or plug is damaged, liquid has been spilled or objects have fallen into the apparatus, the apparatus has been exposed to rain or moisture, does not operate normally, or has been dropped
- Do not remove covers

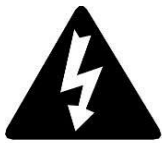

DO NOT EXPOSE TO  
RAIN OR MOISTURE



NE PAS EXPOSER A LA  
PLUIE NI A L'HUMIDITE



- Do not remove any protective earth or signal cable shield connections

## Unpacking the Units

After unpacking the unit, please check it carefully for any damage. If any is found, immediately notify the carrier concerned – you, the consignee, must instigate any claim. Please retain all packaging in case you need to return the unit.

Please consider the environment. When the product has reached the end of its useful life, please dispose of it responsibly through a recycling centre.

## System Overview

### TORUS

TORUS arrays are created using the two models in the series; the T1215 and T1230. Both feature a single 12" (300mm) Neodymium magnet low frequency drivers which are phase plug loaded for increased mid-band sensitivity.

The high frequency element comprises three 1.4" (35mm) Neodymium Polymer Dome compression drivers loaded with a manually adjustable Dynamic Horn Flare™ offering horizontal dispersion options of 60°, 90° or 75° Asymmetrical.



The two models differ only in their vertical dispersion. The T1215 has a 15° vertical dispersion, the T1230 has a 30° vertical dispersion.

TORUS is extremely versatile and is suitable for short to medium throw applications with comprehensive rigging offering solutions for a huge variety of coverage requirements to meet virtually any shape of venue.

### Mechanical Design

TORUS enclosures are built from marine grade plywood finished in hard-wearing, water resistant PU paint. Ergonomic handles make for ease of transportation and deployment.

The rigging allows for up to 6 cabinets to be flown in a horizontal or vertical configurations and arrays can comprise of both models to tailor the coverage to meet the requirements.

When flying TORUS vertically the HF horn can be positioned on the left or the right to create symmetrical system design.

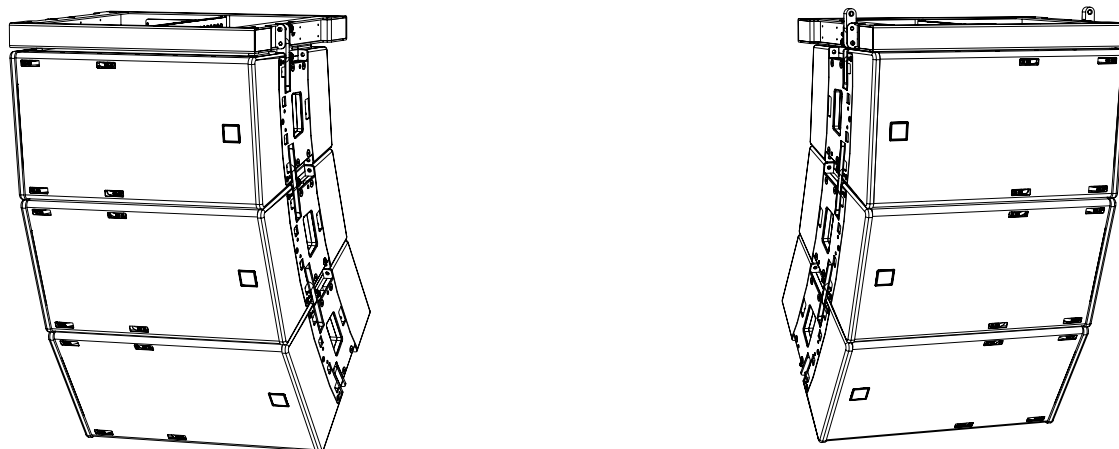

In a horizontal array the HF horn can be positioned at the top or bottom of the array.

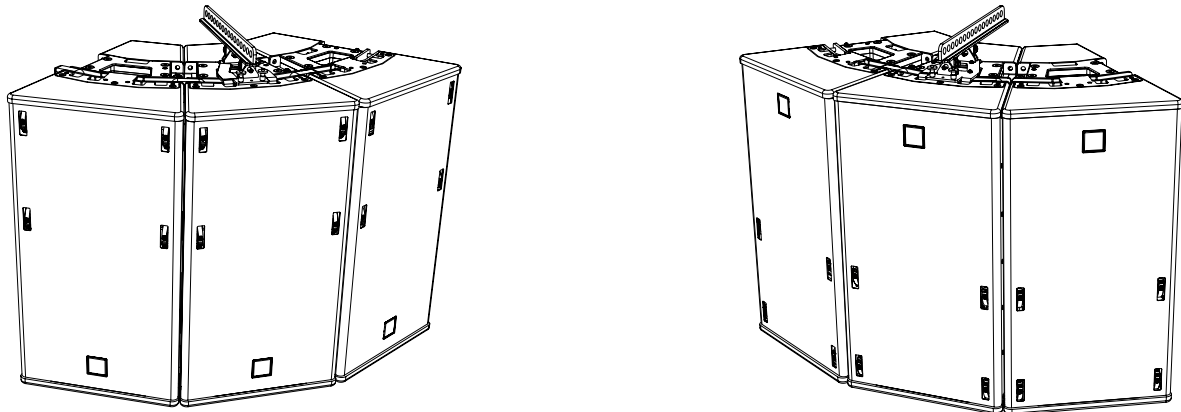

**Acoustic Design**

TORUS low frequency section consists of a 12” (300mm) neodymium driver in a ported reflex configuration to maximise low frequency extension. The driver is fitted with a phase plug in front of the cone to increase mid-band sensitivity to enhance projection in the vital vocal band of frequencies.

The HF section consists of 3 x 1.4” (35mm) exit neodymium compression drivers mounted on a Dynamic Horn Flare™ with a flexible pattern control that can be manually adjusted between 90°, 60° or 75° (Asymmetrical). The system moves and locks the waveguide whilst also adjusting the horn mouth including the low diffraction termination into the baffle which ensures that the horn geometry remains correct to produce the optimum settings for the dispersion you have selected.

The horn is adjusted from the front of the cabinet. This is done without the need to remove the grille.

**Landscape Deployment**

TORUS combined in landscape creates a vertical array. In this mode the combined fixed angle of the cabinets becomes the vertical dispersion, and the flexible dispersion can be adjusted in the horizontal.

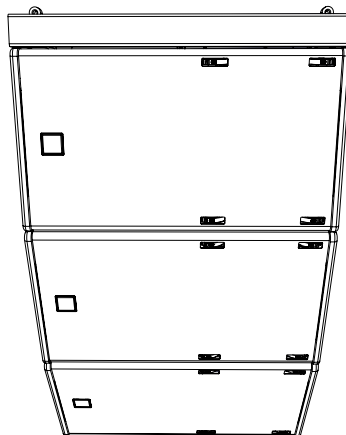

**Portrait Deployment**

TORUS combined in portrait creates a horizontal array. In this mode the combined fixed angle of the cabinets becomes the horizontal dispersion, and the flexible dispersion can be adjusted in the vertical.

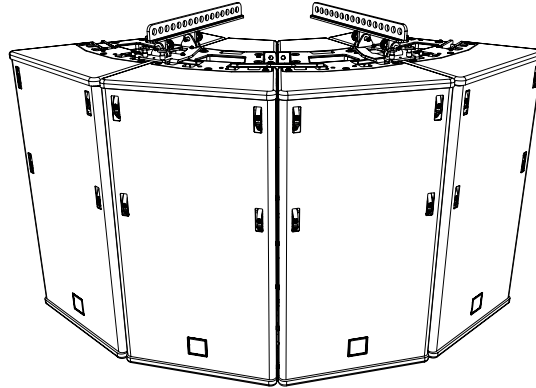

**Changing Horn Dispersion**

To adjust the angle, rotate the thumbwheels at the top and bottom of the grille. Each side is adjusted in 15° increments showing either “45°” or “30°”. If both sides are at their widest position the total dispersion is 90°, by adjusting one side down by 15° from 45° to 30° the dispersion will be 75° asymmetrical with a bias to the left or right depending on which side of the horn you have adjusted. With both set to the minimum angle the dispersion reverts to a symmetrical 60° Indicators on the thumbwheels show which angle the horn is set to.

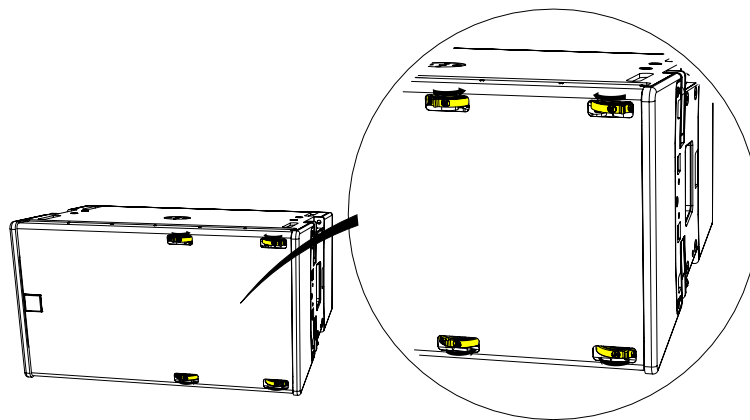

## Accessories

### T12POLERIG



The T12POLERIG allows a single cabinet (T1215 or T1230) to be mounted using a standard 35mm speaker stand or a 35mm distance bar when used in conjunction with one of the SX Series Subwoofers fitted with a pole mount insert.

The T12POLERIG can be fitted to the top or the bottom of the cabinet allowing systems to be mirrored with the high frequency horn either to the left or the right.

### T12GRID

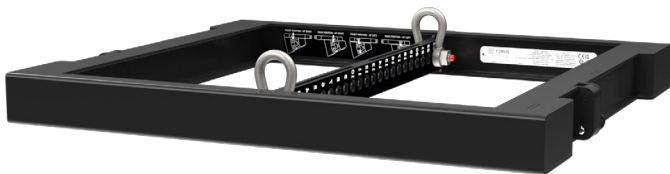

The T12GRID is used to vertically array TORUS for up to 6 cabinets. Cabinets may be flown from the T12GRID inverted allowing stereo arrays to be mirrored with the high frequency horn either to the left or the right.

### SBAR



The SBAR allows a single cabinet to be flown in “landscape” mode. 5 holes give various angle options for up and down tilt. An adaptor is included for truss mounting.

The SBAR can be fitted to the top or the bottom of the cabinet allowing stereo systems to be mirrored with the high frequency horn either to the left or the right.

### T12HRIG



The T12HRIG is used to horizontally array TORUS for up to 6 cabinets. A single HRIG can be used to suspend up to 3 T12 cabinets and arrays consisting of 4 to 6 cabinets use 2 x T12HRIG.

**T12TRIG**



The TRIG is a transition grid between vertically arrayed TORUS SXCF118 subwoofers.

**T12GSRIG**



The T12GSRIG allows for up to 3 x TORUS cabinets to be mechanically ground - stacked to SXCF118 subwoofers for safe deployment.

**T12PB**



The T12PB allows up to 6 x TORUS to be flown in vertical arrays without any array angle limit. It can also be used as a pullback/array stabilizing accessory when used with a T12GRID.

## Recommended Subwoofer

### SXCF118



Whilst a TORUS array can be complimented with any of the SX Series subwoofers, the SXCF118 is an idea choice for vertical TORUS arrays where a flown subwoofer is required in a combined array. By using the T12TRIG, TORUS can be flown directly under an array of SXCF118 subwoofers.

The SXCF118 is a compact, high performance cardioid subwoofer, combining maximum low frequency output with pattern control. It features an 18" (460mm) forward facing driver and a 14" (356mm) rear facing driver, each driven independently by separate amplifier channels and DSP. Each driver has its own chamber with optimised bass reflex porting. This arrangement produces a cardioid dispersion pattern which maximises the front radiation and reduces unwanted radiation behind the subwoofer.

The enclosure is constructed from multi-laminate plywood and coated with hard-wearing textured black polyurea. Rigid perforated steel grilles protect the front and rear of the enclosure, while interlocking skids protect the top and bottom surfaces and prevent movement when stacked. An M20 threaded insert allows for pole mounting of TORUS systems.

# Amplification

## iKON Amplifiers



For the best possible performance T1215 and T1230 are powered and controlled using iKON amplifiers. Presets are dynamically created using Martin Audio’s DISPLAY 3 prediction software. Once optimised the parameters can be exported from DISPLAY 3 and uploaded to the iKON amplifiers via VU-NET control software.

Ethernet is used for system remote control and monitoring via Martin Audio’s VU-NET software application, while a front panel interface allows full local control of all features.

Dante digital audio network inputs are also provided for digital audio distribution and control. Powerful DSP is integrated to ensure maximum performance and compatibility. It also provides up to 1000 FIR filter taps @ 48kHz on each output channel, which is essential to implement DISPLAY’s bandwidth optimisation process in TORUS systems. iKON amplifiers provide comprehensive protection functions to maintain safe operating conditions of both the amplifier and the loudspeakers driven — including a sophisticated loudspeaker limiter suite which incorporates peak, RMS and excursion limiting, as well as multiband limiting for passive 2-way systems.



# DISPLAY 3.0

## Overview

DISPLAY 3 is modelling software that predicts coverage and SPL for Martin Audio loudspeakers in a 3D environment.

Optimised Array, Constant curvature, point source and subwoofer solutions can be reviewed, and system designs validated.

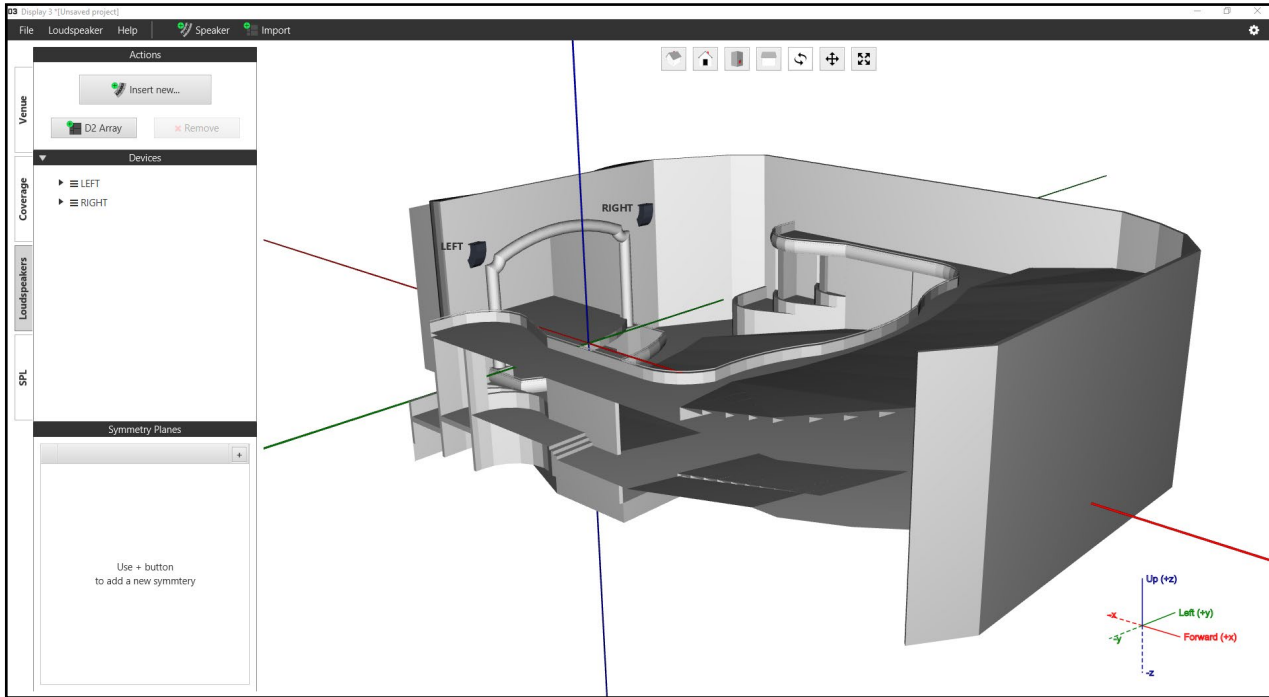

Within the application, venue creation is achieved via an import from Sketchup or by extruding a 2D slice from Display 2 software.

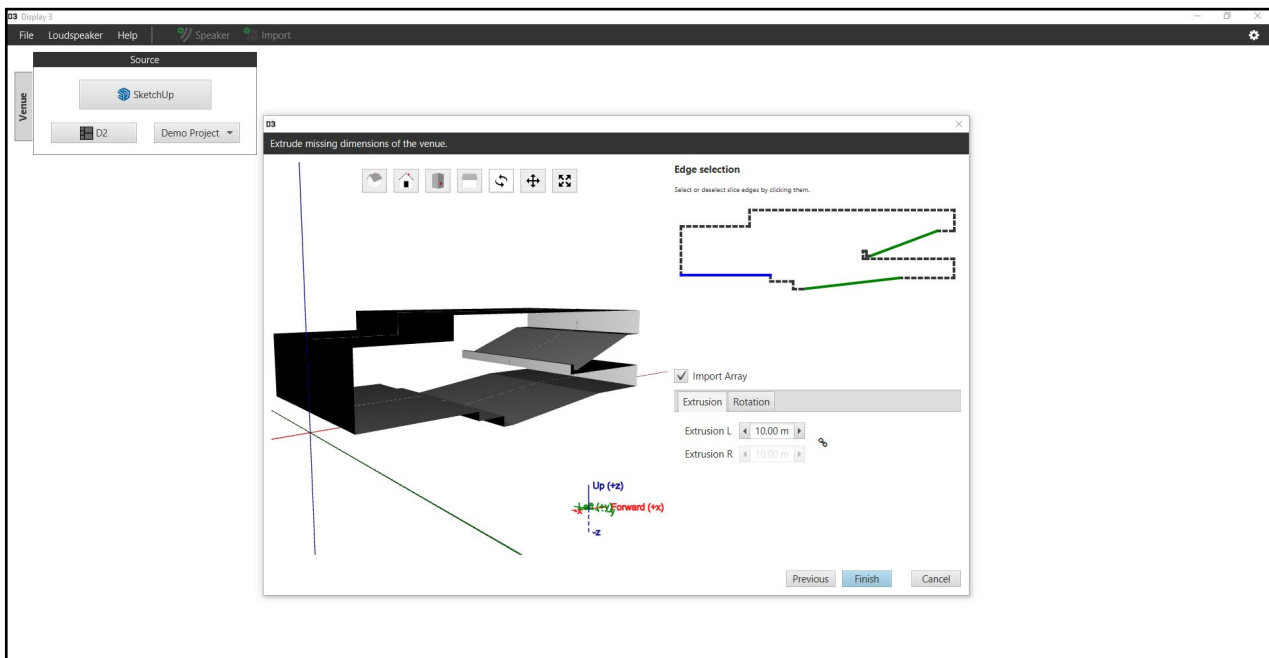

Display 3 utilizes tags or layers inherited from Sketchup or created natively if using a Display 2 import.

Layers can be used to define coverage parameters; audience, non-audience or hard avoid. These surface types define the offset with which SPL is mapped.

The auto-assign button in the coverage tool automates this process.

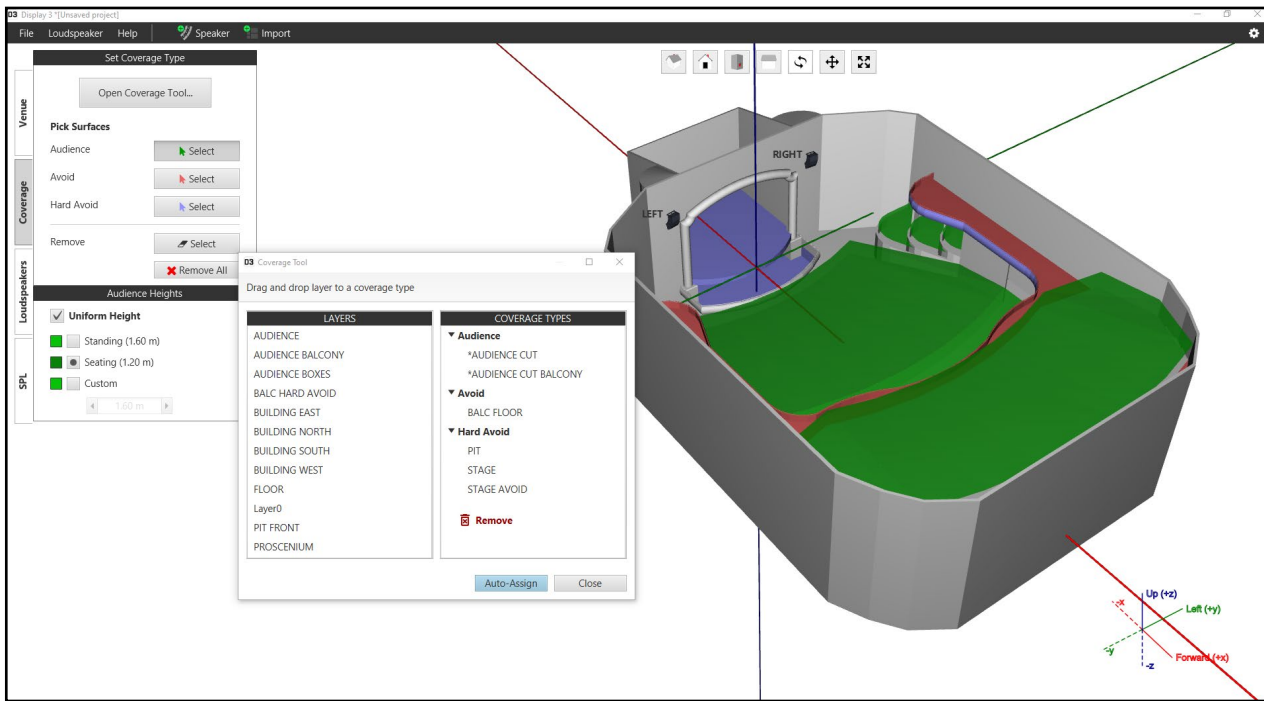

Loudspeakers are inserted from the loudspeaker library or imported from a Display 2 file.

TORUS constant curvature systems for example can be deployed horizontally or vertically, with cabinet type, quantity and horn angle defined from the loudspeaker inspector menu.

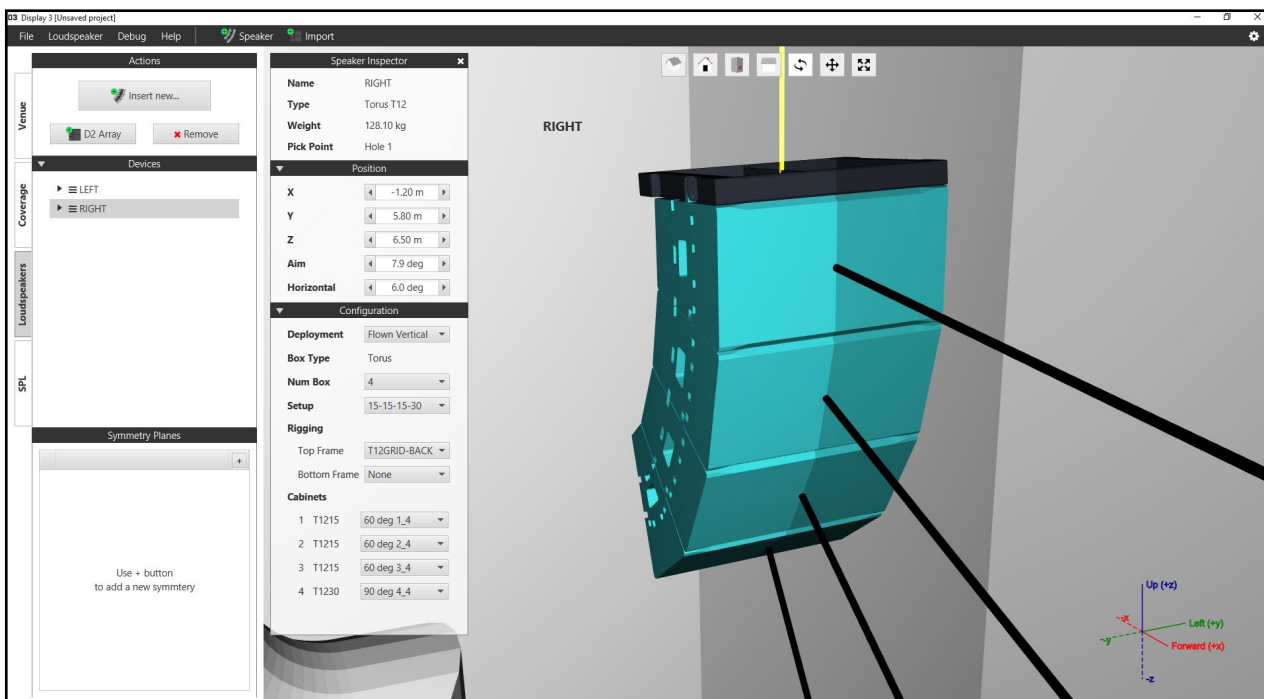

SPL mapping shows the predicted output of the system with the selected input signal and gain structure.

Selecting the MAX button automatically sets the input level to the limit of the entire system. The resultant SPL map will be that of the system as the first loudspeaker goes into limit.

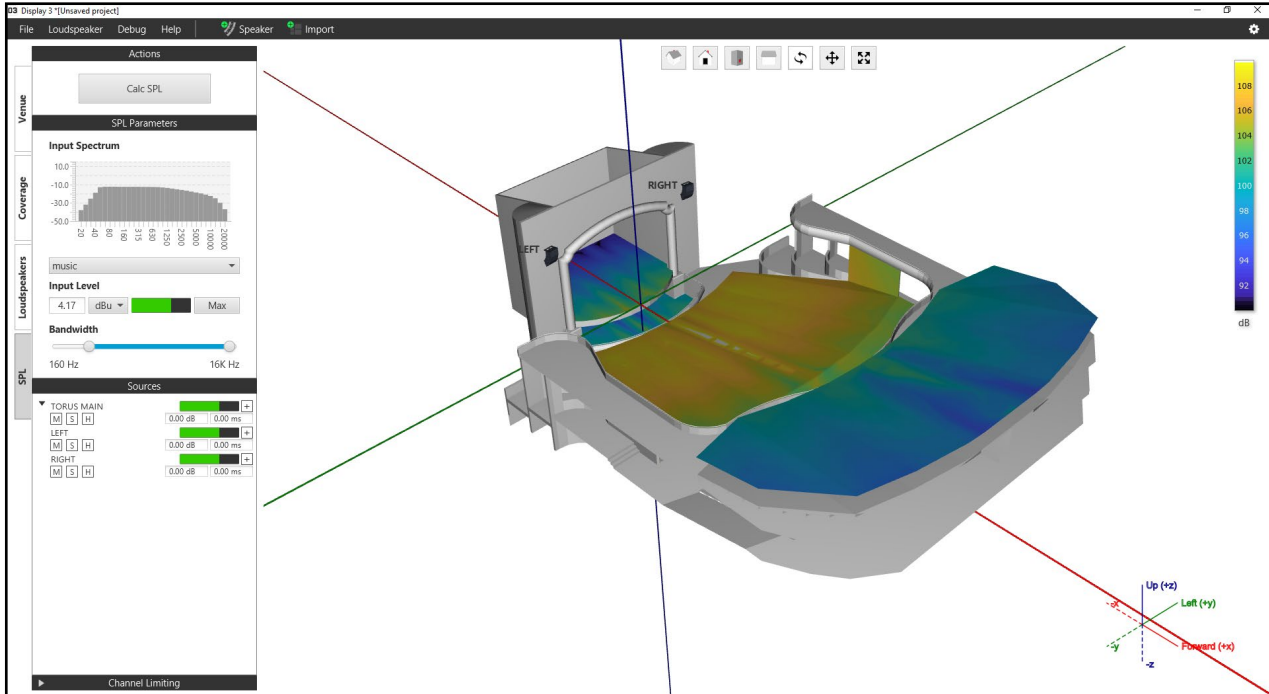

Display 3 is part of a developing roadmap of software releases whereby tools and features are incrementally released over time.

Display 3 can be downloaded from the Martin Audio website; <https://martin-audio.com/support/software>

# VU-NET 2.2

## Overview

Vu-Net is control software for iKON, MLA and CDD LIVE products. Load factory presets and optimisations, monitor system performance in real-time and have control over gain, EQ routing and delay via a networked infrastructure.

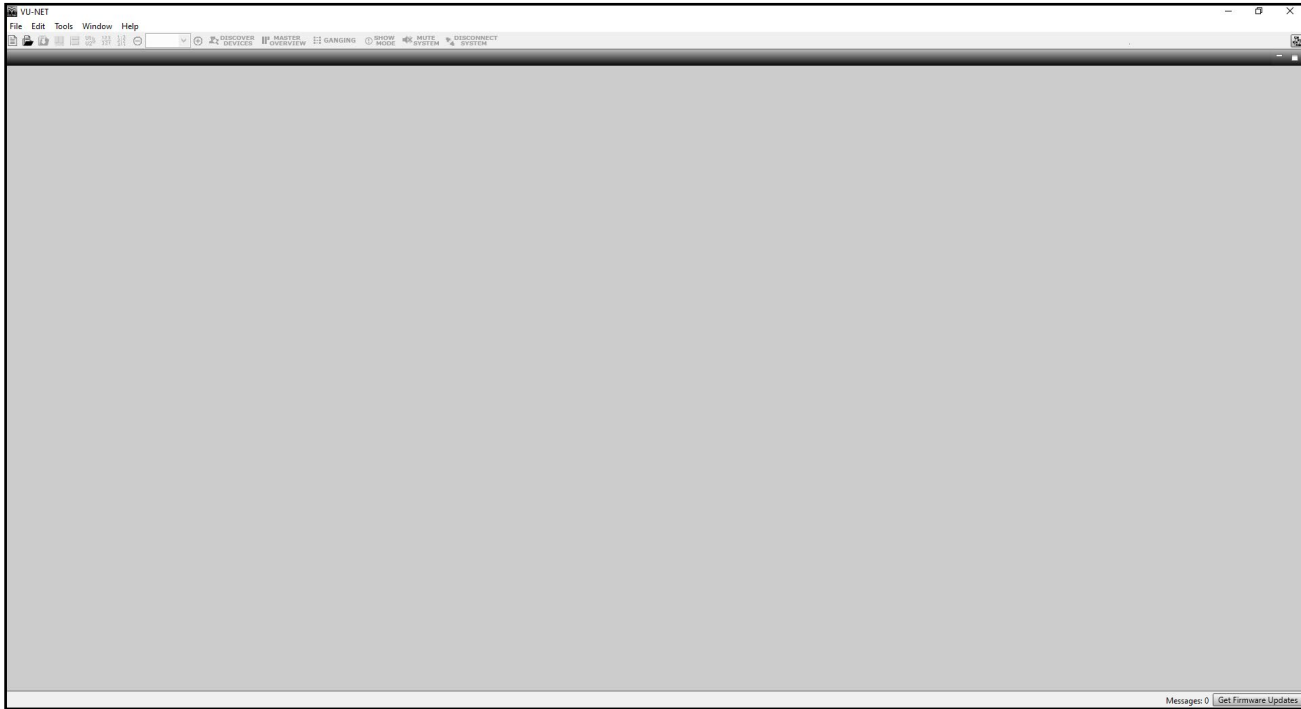

Devices can be added manually using the Palette on the left, but this has limited use. In practical applications, the Discover Devices button is used.

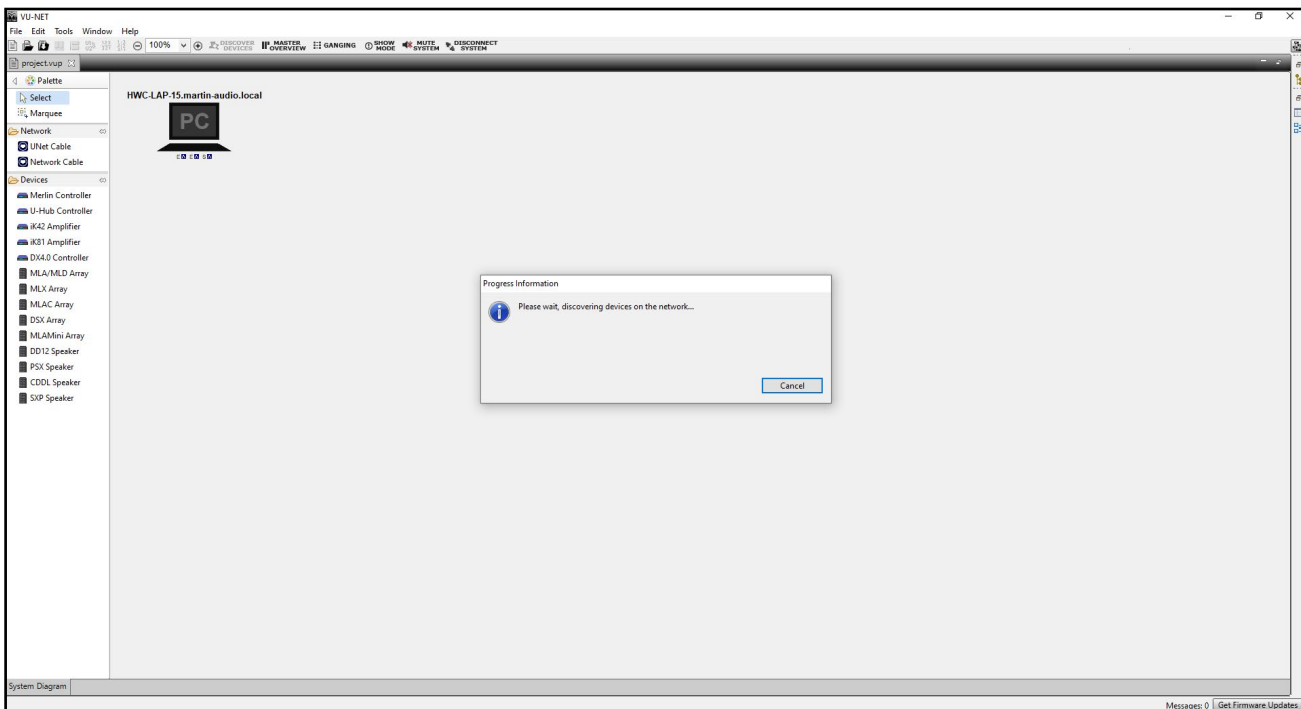

The application searches the network for all Vu-Net enabled devices and will add them to the project upon discovery.

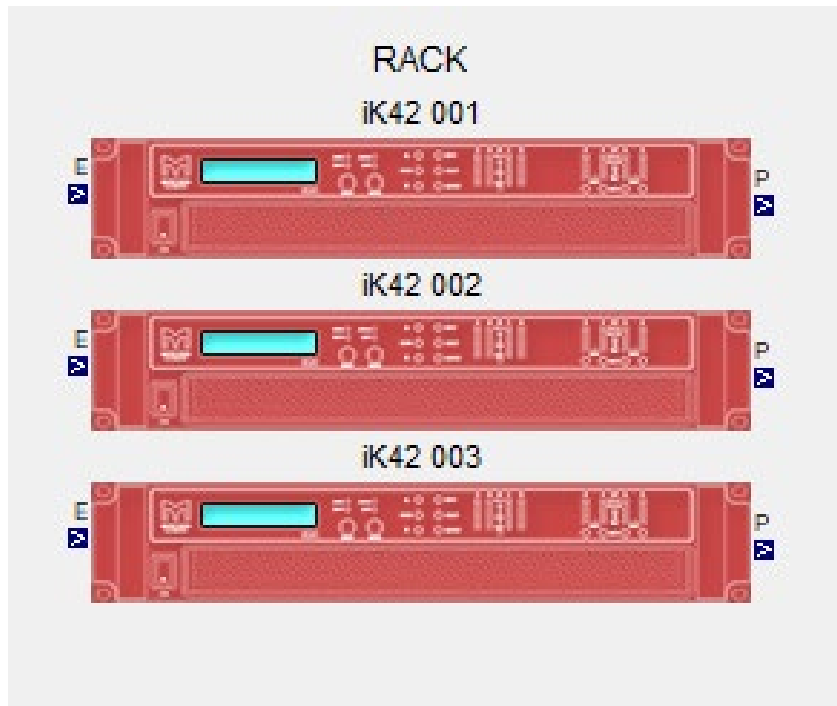

Presets are added to the amplifiers using the preset manager. Right click an amplifier to access the preset manager.



When loading a TORUS T12 preset, first select the deployment type, followed by the number of speakers and amplifier channels used to drive the array.

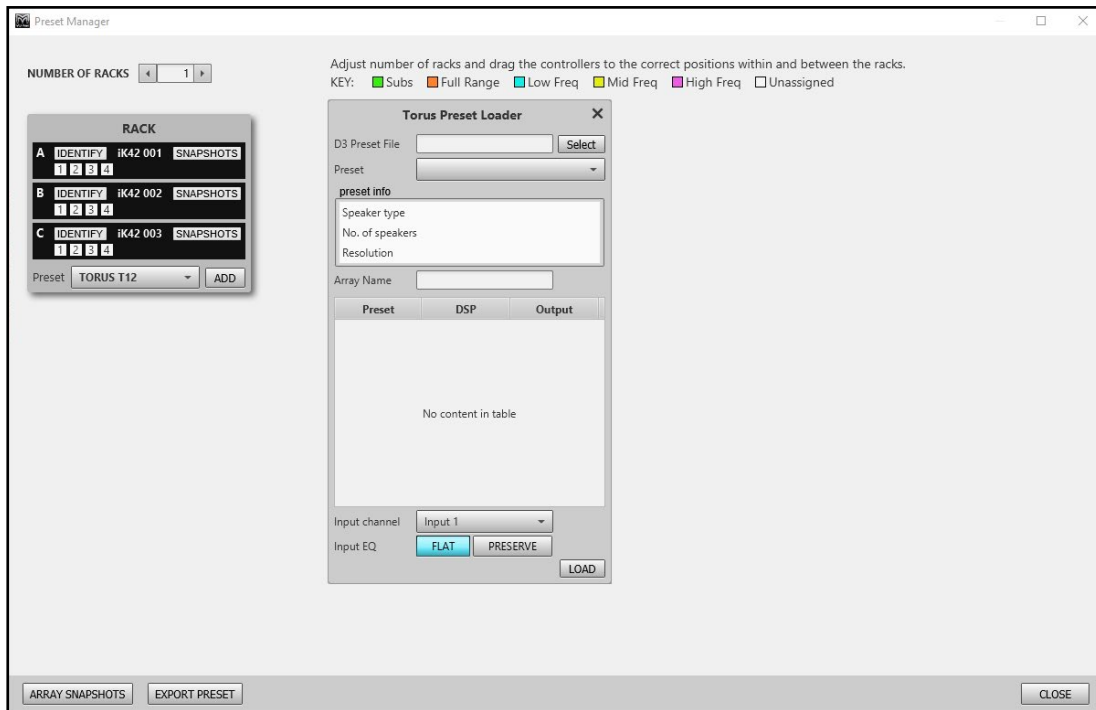

The preset info box displays a coloured graphic of the T12 array showing how it should be wired. For vertical systems, the array is wired from top to bottom and for horizontal systems, it is wired from the centre out.

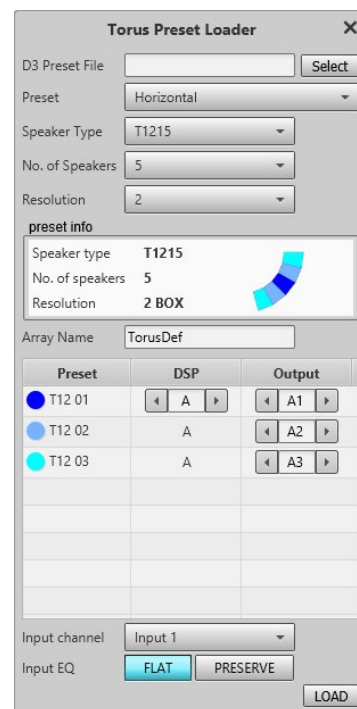
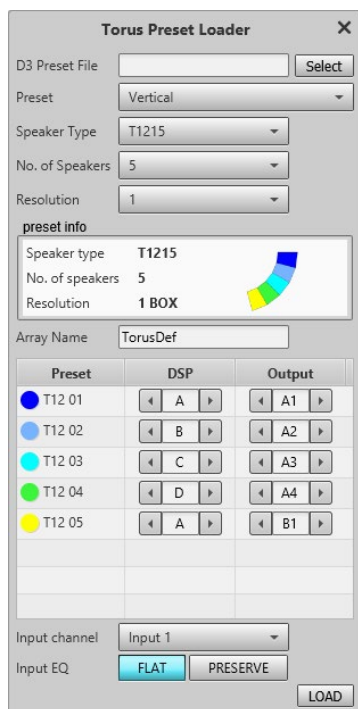

The table is used to select the DSP and output channel used per circuit. For vertical T12 arrays, independent DSP channels can be assigned to each circuit.

An FIR Hi-Shelf is available on the DSP EQ to control the balance of the array.

For horizontal arrays, only one DSP channel is required.

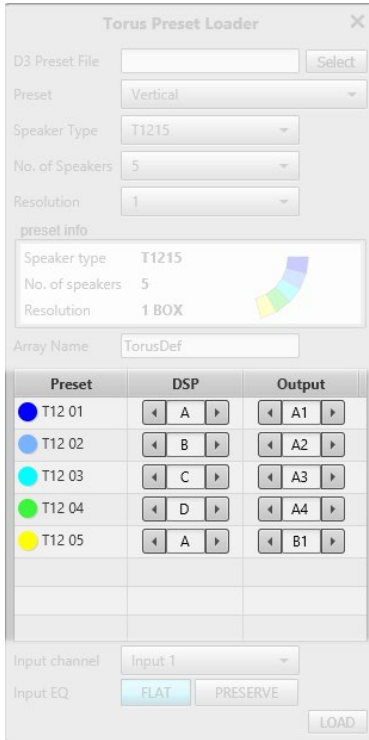

TORUS cabinets have an LED for identification, this can be toggled from within the amplifier's control panel. The output channel is muted to prevent audio from passing to the circuit when the LED is active.

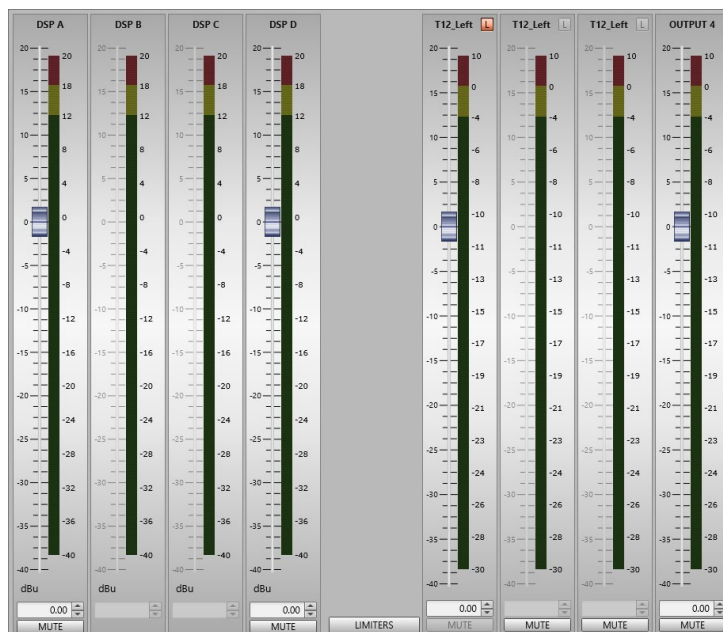

Input EQ can be adjusted to suit your preferences and to compensate for any difficult acoustics.

PEQs and the Lo-Shelf are ganged across all used DSP channels in the array, whereas the FIR Hi-shelf is independent for each DSP channel.

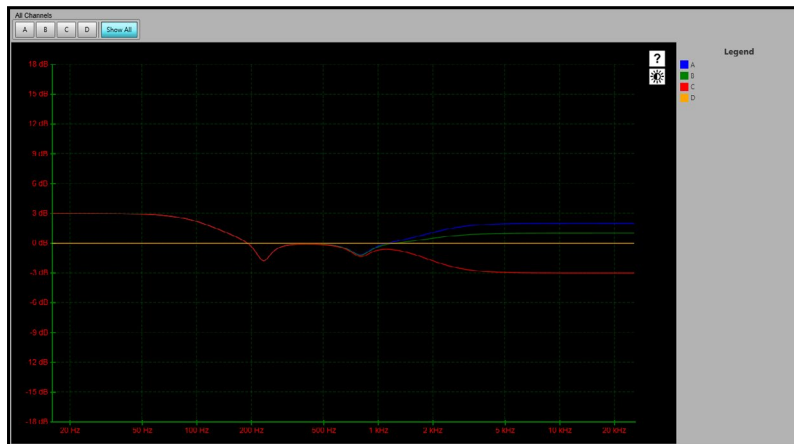

The high-pass filter is available on the Output EQ section for use with a subwoofer.



Vu-Net can be downloaded from the Martin Audio website; <https://martin-audio.com/support/software>



## Connections

### Overview

T12 cabinets have two parallel-wired Neutrik® NL4 connectors recessed at the rear of the cabinet.

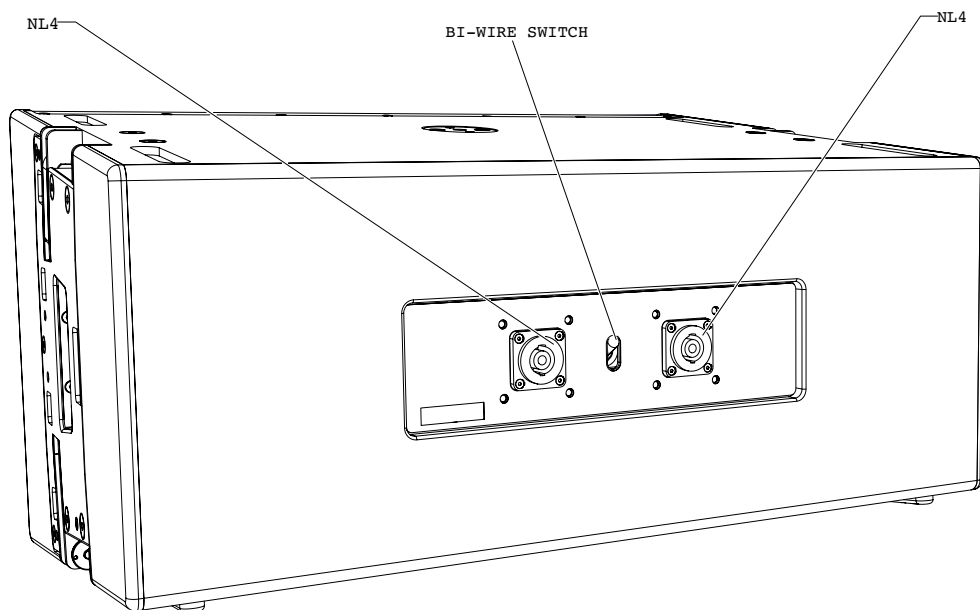

The two NL4s are wired in parallel so either can be used as a nominal ‘input’ or ‘link’ output.

TORUS features a “bi-wire” input configuration that uses both channels of the NL4 connection offering the option of receiving the signal from either pins +/-1 or +/-2. This allows for simplified wiring using a single 4-core speaker cable. For example, if you are running a 6 cabinet array powered by two channels of an IKON amplifier, both channels can be routed via a 4-core speaker cable to the first TORUS cabinet. All other cabinets are linked with short NL4 cables running from the LINK OUT on one cabinet to the INPUT on the next. The first three cabinets are switched to receive their feed from pins 1+/-, the remaining three cabinets are switched to pins 2+/- . The first three cabinets are now powered by channel 1 on the amplifier, the other three from channel 2. As all TORUS cabinets have an impedance of 8 with three cabinets in parallel on each channel they will both see an impedance of approximately 3.6

# Rigging

## Overview

TORUS consists of a single-point rigging system located on either side of the cabinet, all hardware is captive and can be stored conveniently for transportation.

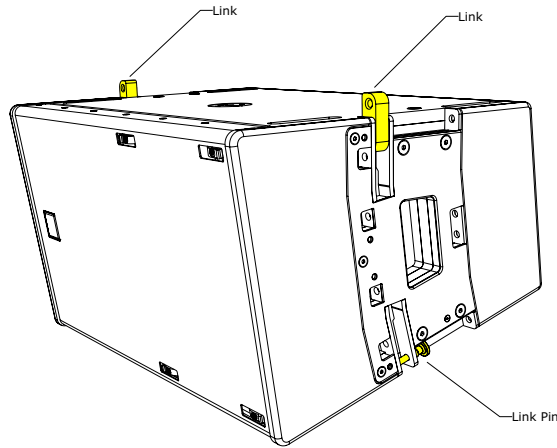

The fixed angled enclosure can be arrayed vertically and horizontally and deployed in various configurations with additional hardware.

## T12GRID

The T12GRID suspends TORUS using either a single or dual lifting point up to a maximum of 6 cabinets, allowing both positive (up-tilt) and negative (down-tilt) array angles. The T12GRID can also accommodate both left- and right-handed arrays. Mounting for an inclinometer allows the vertical array angle to be monitor via a display.

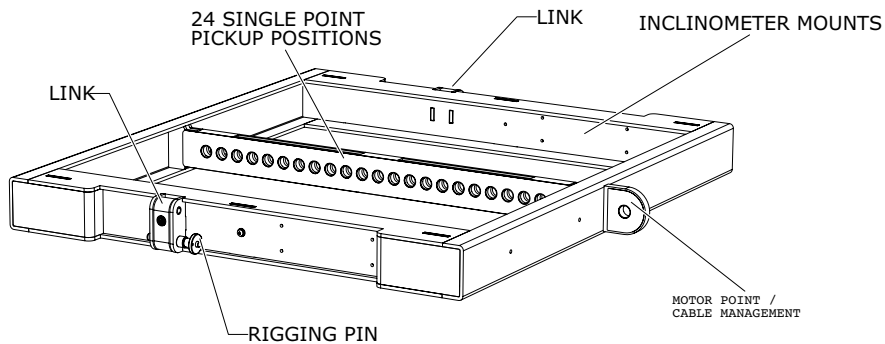

### Inclinometer Assembly

Martin Audio supplies an optional remote angle monitoring system which can be used to check the tilt angle of the array. It consists of a sensor (mounted within the flying frame) and a remote display unit. Interconnection is via a standard XLR mic cable.

#### *Fitting the inclinometer sensor to the flying frame*

The TORUS flying grid may be fitted with an inclinometer sensor which is available as an optional accessory.

To install the inclinometer a 2.5mm hex tool is required

The sensor is attached to the grid with 4 x M4 button head screws

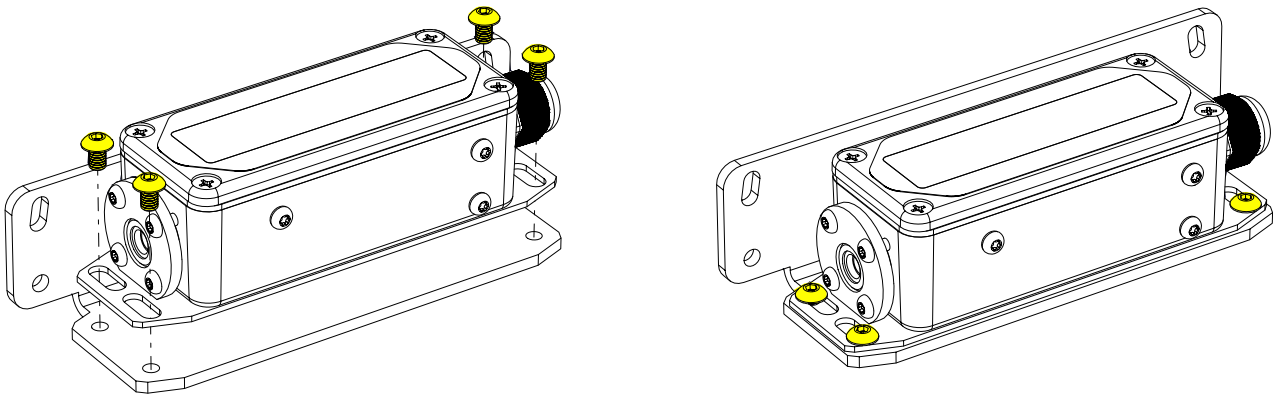

Attach the inclinometer and bracket assembly to the T12GRID using the 2 x M4 fixings provided. Front end is fixed using the bottom hole and rear end is fixed using the upper slot.

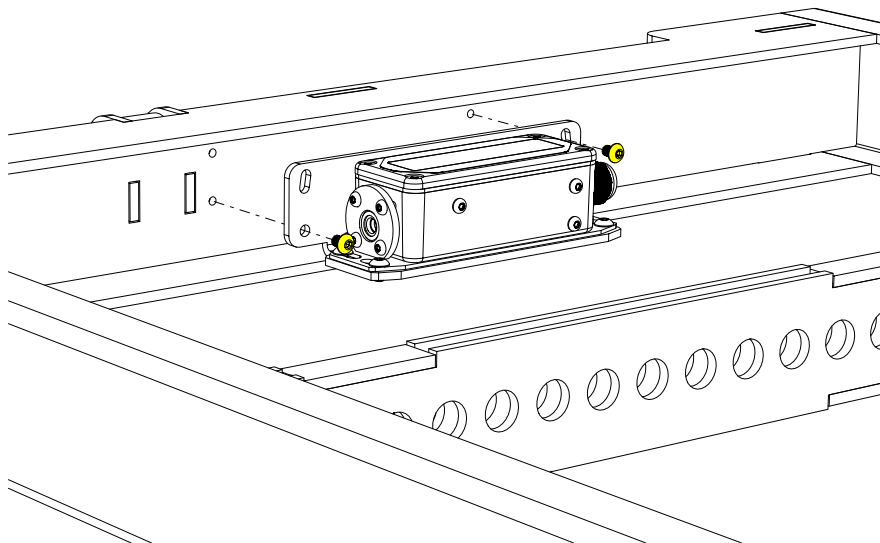

Before tightening use the rear slot to adjust the position of the Inclinator assembly to make sure it is seated correctly

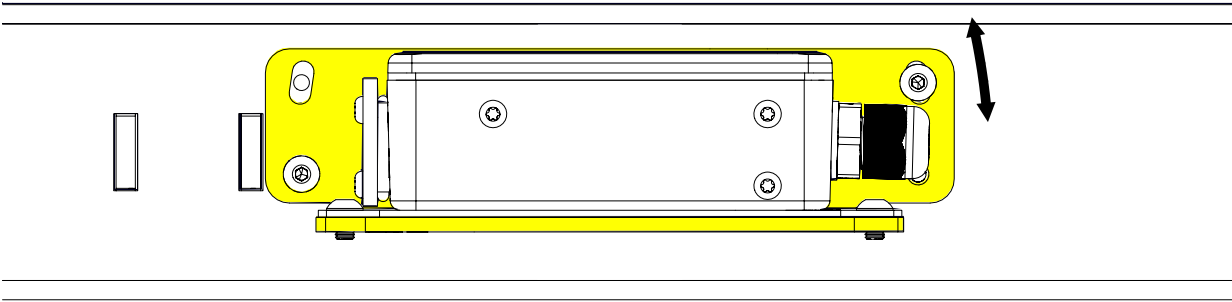

The sensor can be fitted to both sides of T12GRID and various orientations allowing to be used for every array configuration

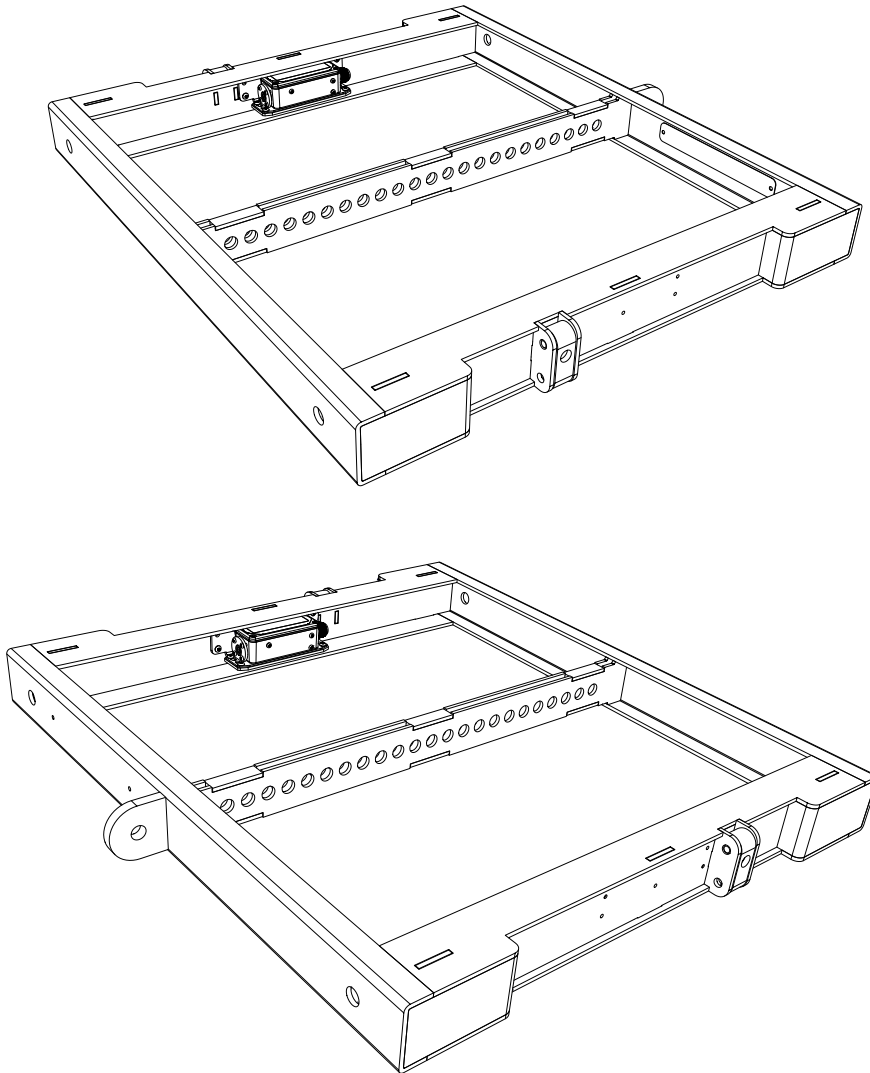

Note that a single inclinometer reader can be used with multiple sensors. It is not necessary to have the same number of displays as sensors.

**Flying the Array**

When flying TORUS vertically the HF horn can be positioned on the left or the right to create symmetrical system design.

*Linking down – HF horn to the left*

*Linking up – HF horn to the right*

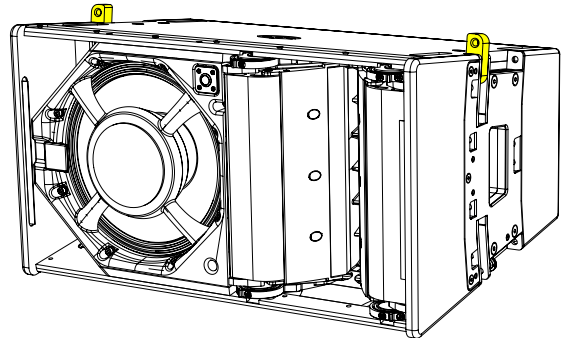
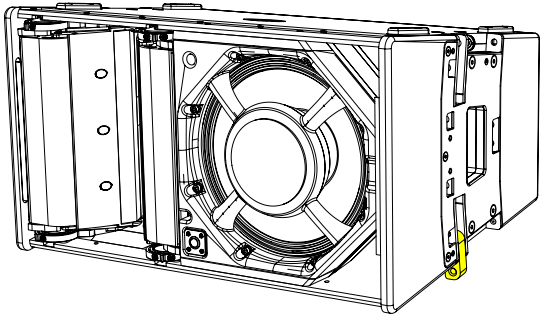

*HF Left*

Remove rigging pin and rotate the link through 180 degrees.

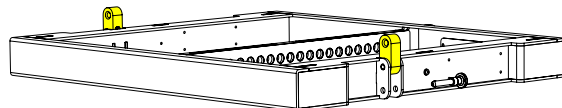
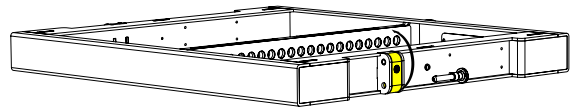
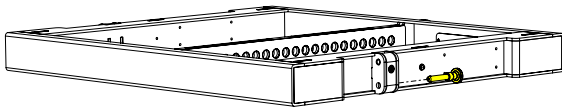

Position the T12GRID on top of the TORUS cabinet, rotate the links and insert the rigging pins. Make sure the cabinet is secured on both sides before lifting.

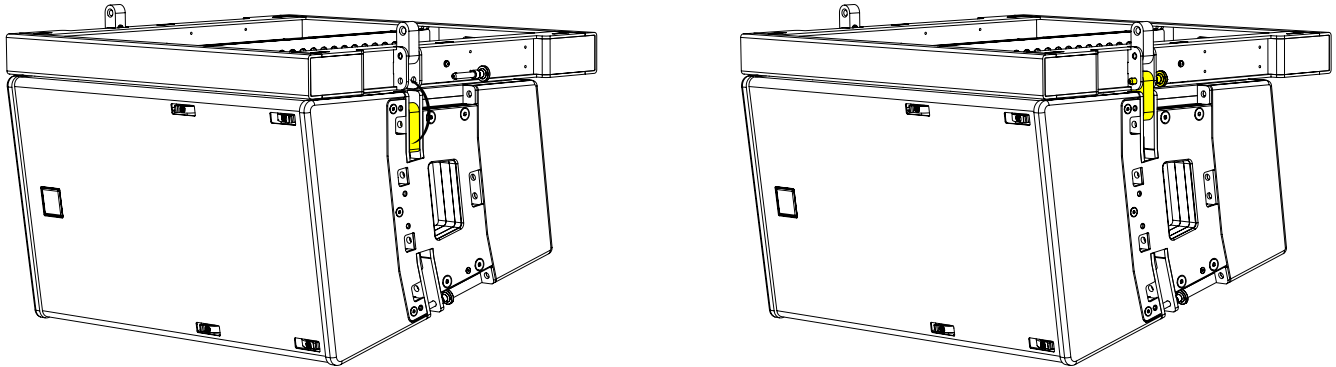

Lift the array to a height where the next cabinet can be positioned underneath. Either lift the cabinet into position or lower the T12GRID onto the cabinet below.

Remove the rigging pins from the cabinet above, rotate the links on the cabinet below and insert the rigging pins to secure.

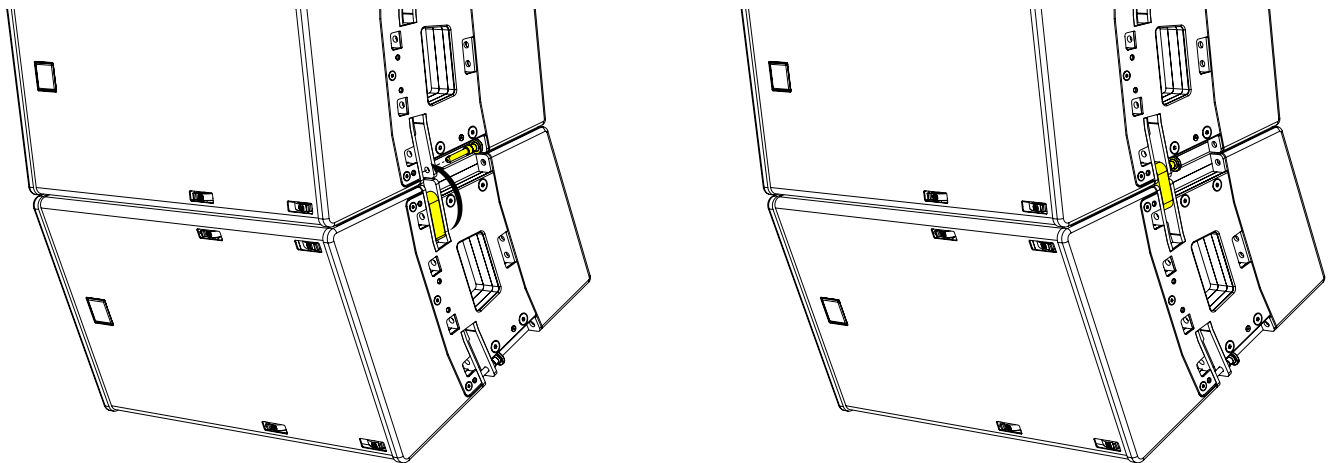

Repeat the process until the desired amount of TORUS have been vertically arrayed. A maximum of 6 cabinets can be flown from the T12GRID.

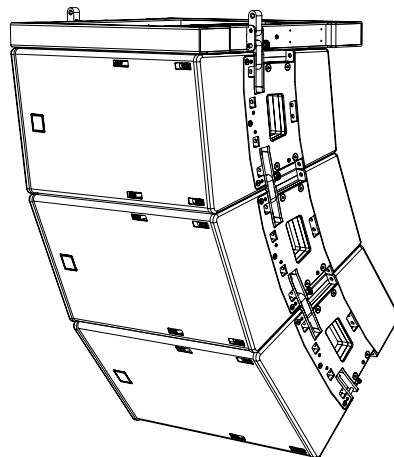

A second T12GRID can be linked to the bottom of the array and used to achieve site angles that are not possible with a single T12GRID. The configuration can also be used to secure the array to stop it moving.

Invert the T12GRID, remove the rigging pins and rotate the T12GRID links. Replace the pins to secure the grid to the cabinet.

Note: The T12GRID rigging pin is not used for this configuration but needs to be remove (then replaced) to rotate the link.

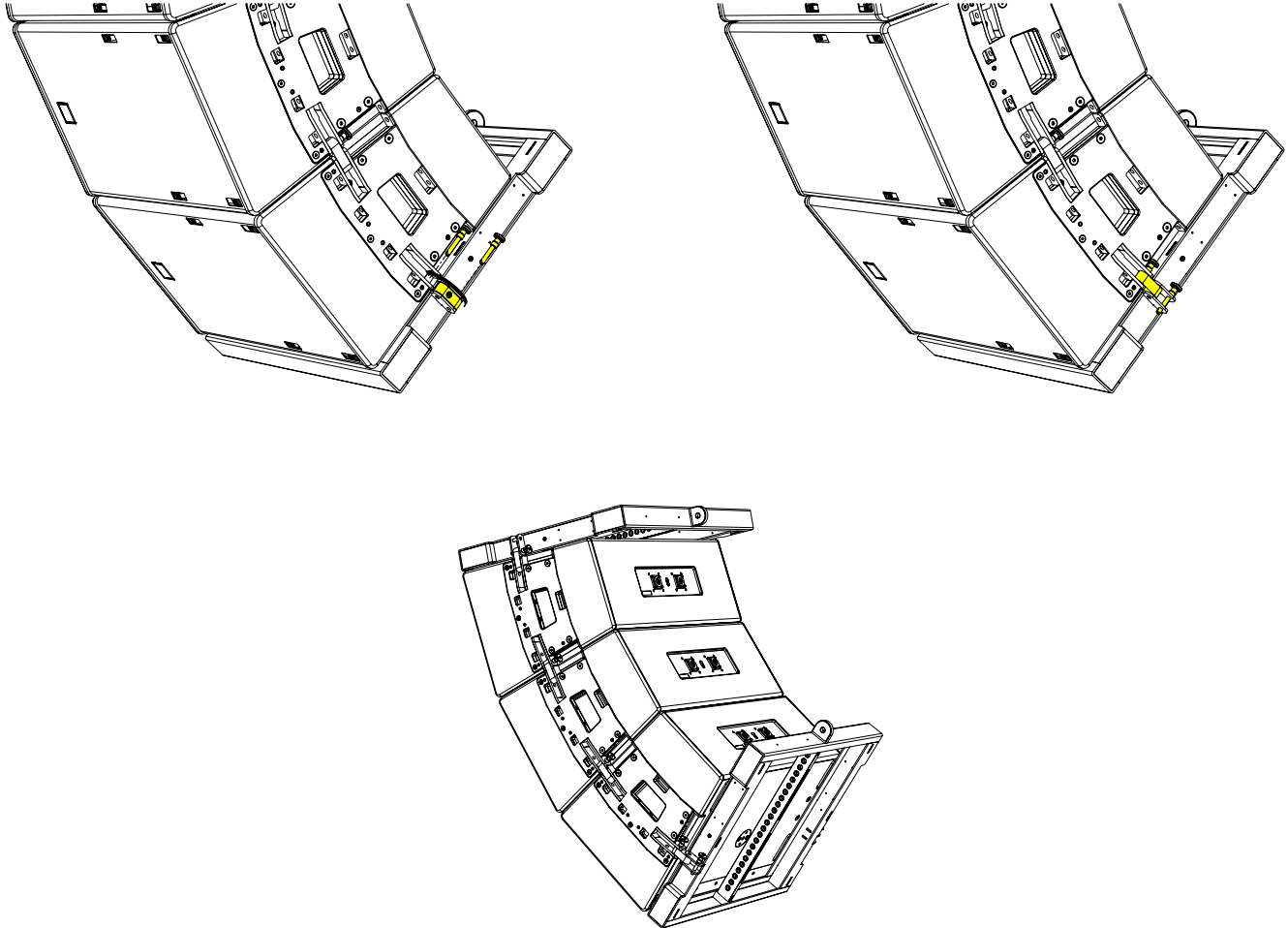

*HF Right*

Rotate the T12GRID so the rigging pins are at the top.

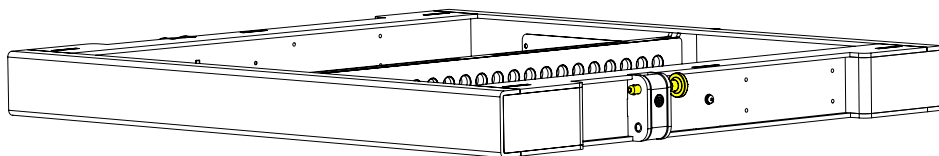

Remove rigging pin and rotate the link through 180 degrees.

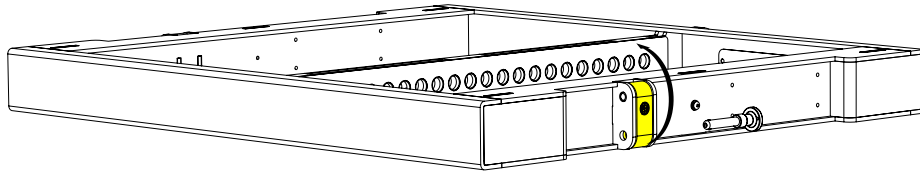

Position the T12GRID on top of the TORUS cabinet and rotate the links and insert the rigging pins to secure. Make sure the cabinet is secured on both sides.

Lift the array to a height where the next cabinet can be positioned underneath. Either lift the cabinet into position or lower the T12GRID onto the cabinet below.

Rotate the links on the cabinet above and insert the rigging pins to secure.

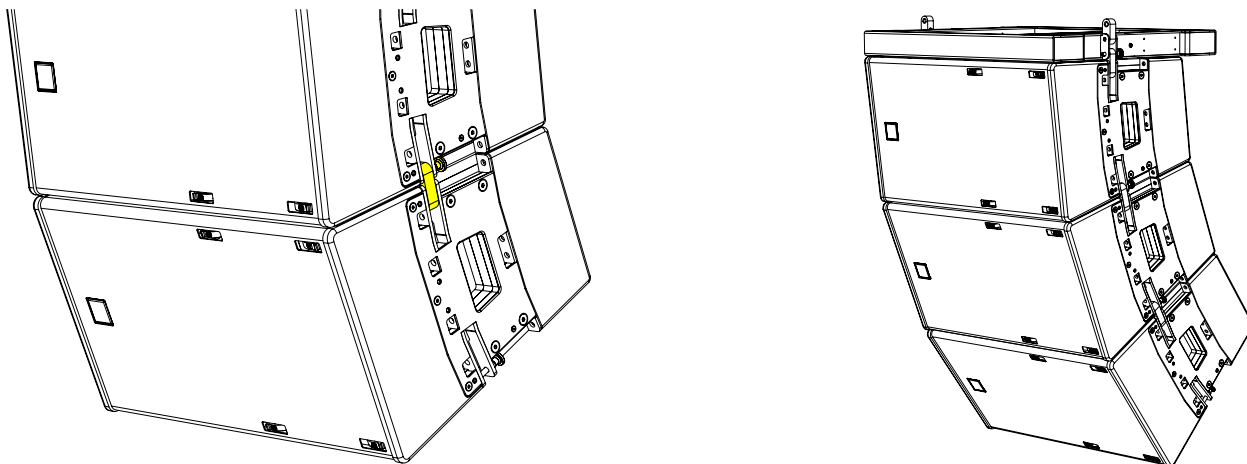

Repeat the process until the desired amount of TORUS have been vertically arrayed. A maximum of 6 cabinets can be flown from the T12GRID.

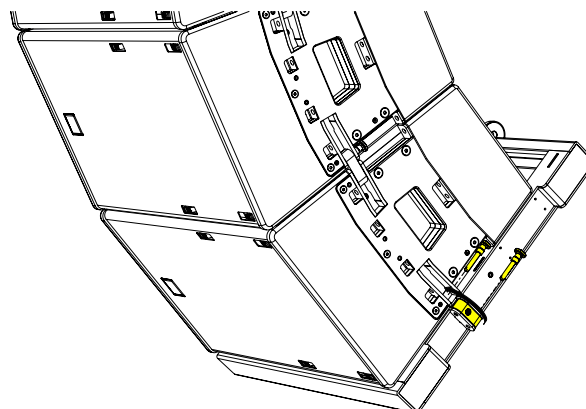



*T12GRID Front and Back Positioning*

T12GRID can be positioned towards the rear of the array to maximise the available down tilt for a single point hang.

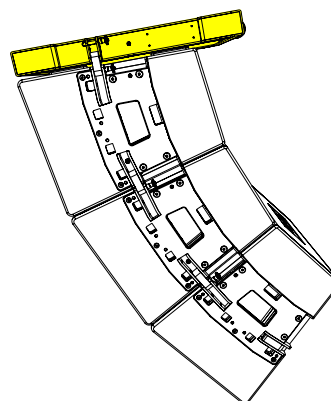
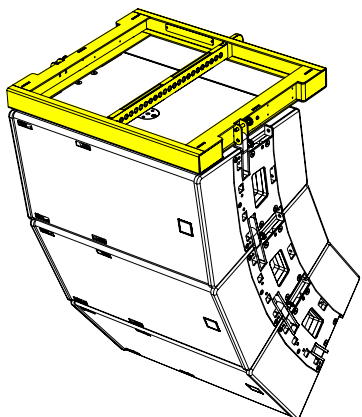

T12GRID can be positioned towards the front of the array to maximise the available up tilt for a single point hang.

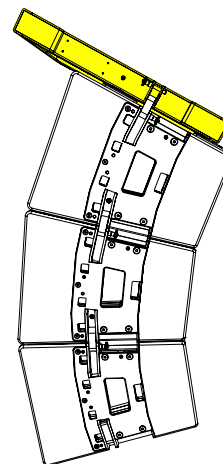
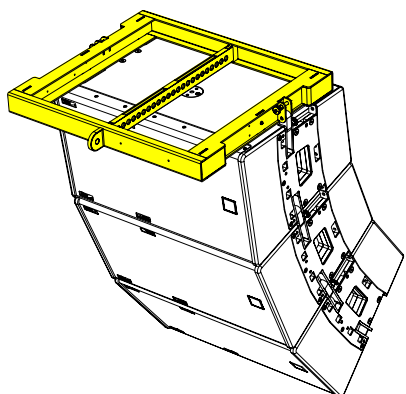

**T12HRIG**

The T12HRIG is a rigging accessory used to suspend TORUS in a horizontal configuration. The T12HRIG can be mounted to a cabinet or between two cabinets, given the best options to suspend multiple cabinets.

T12HRIG can be mounted on the top or bottom of the cabinet in portrait mode, this allows the HF horn to be positioned at the top or the bottom of the array.

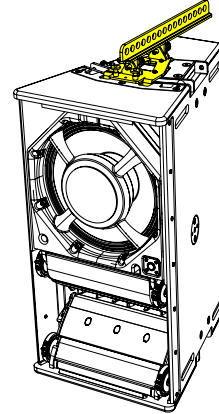
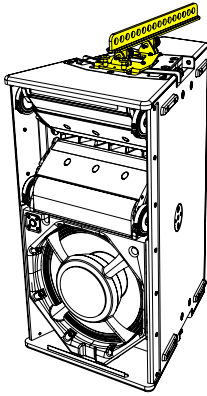

If more than a single cabinet is going to be used rotate the link before mounting the T12HRIG.

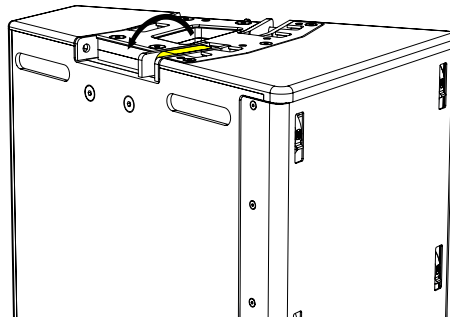

Two mounting options are available depending on the configuration. The T12HRIG can be mounted directly to a TORUS or between two cabinets.

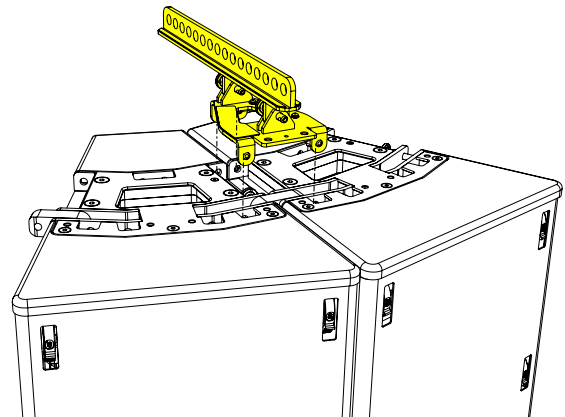
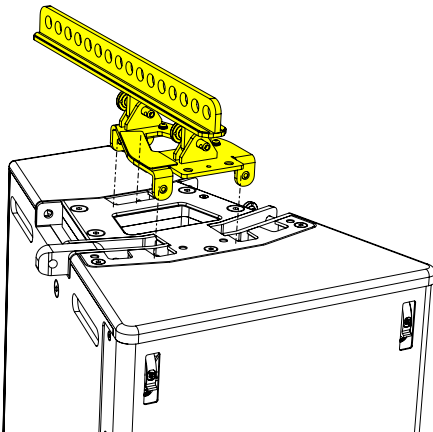

Attached the T12HRIG making sure all four pins (two back and two front) locate and lock into position.

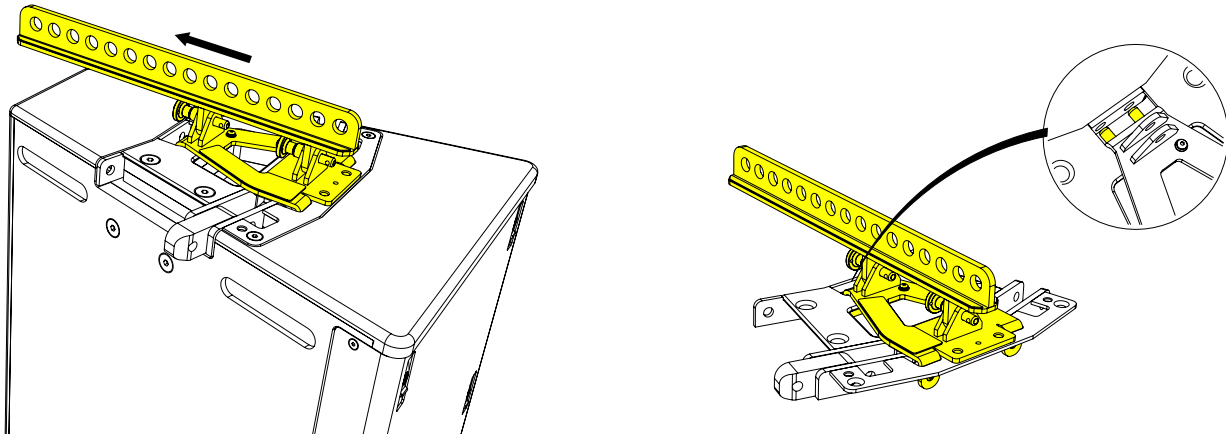

The T12HRIG is only secure when the two locking pins have been inserted and locked into place.

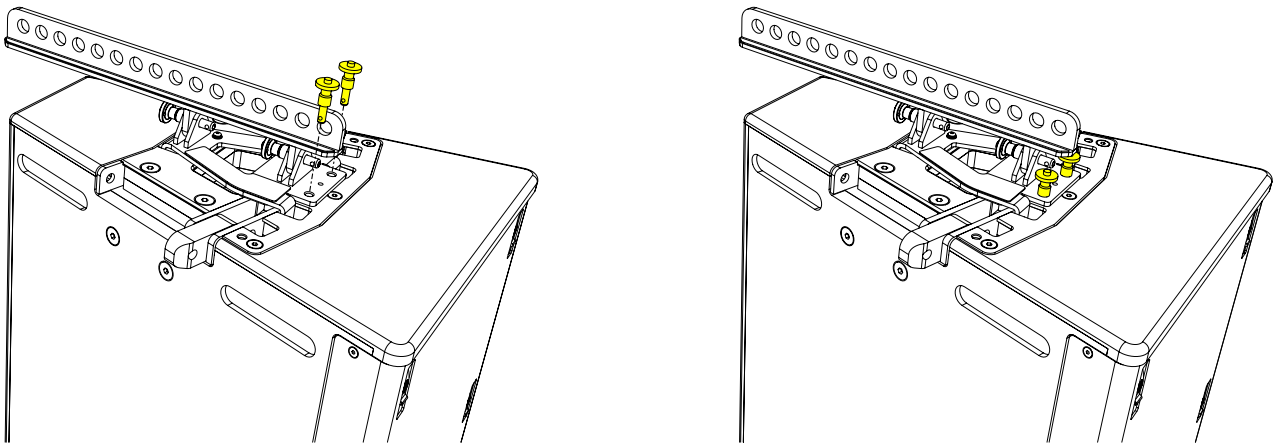

Add more TORUS by aligning the skids to the adjacent cabinet.

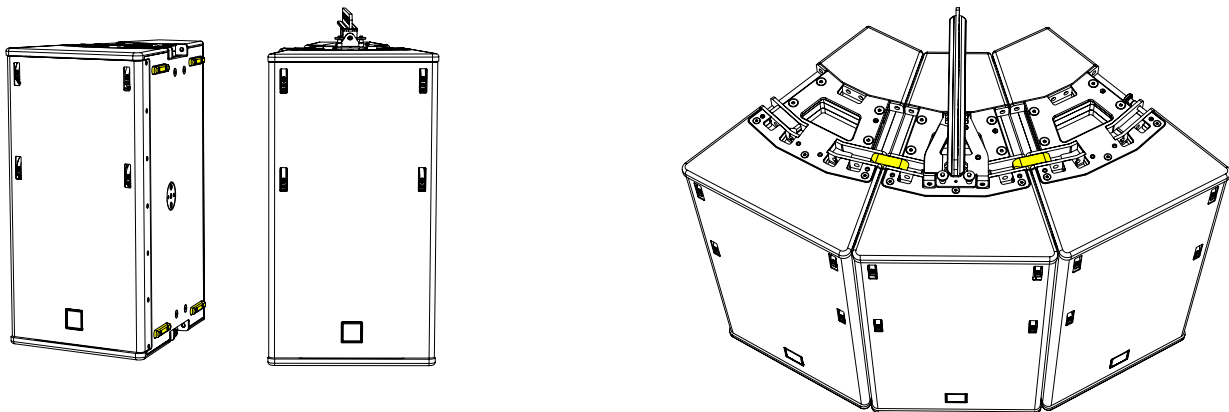

Replace pins and lock the top of the cabinets together.

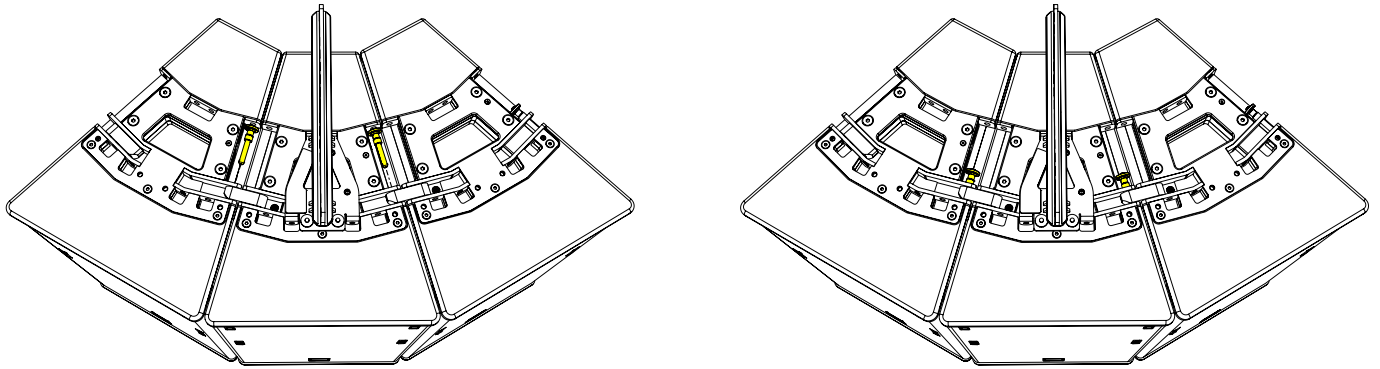

Lift the array and remove the rigging pins on the bottom of the array. Rotate the links into position.

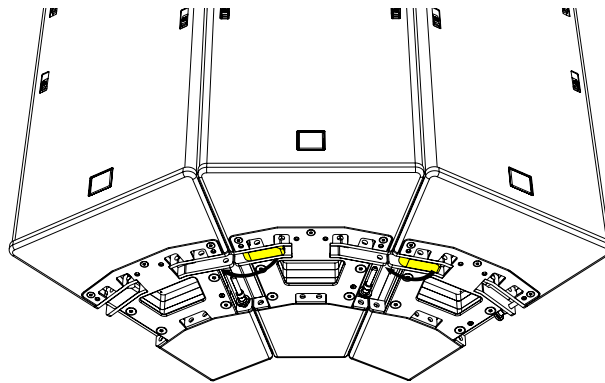

Replace the pins to link the bottom of the cabinets together.

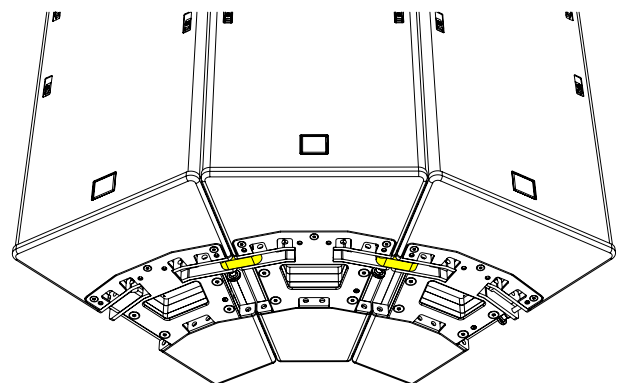
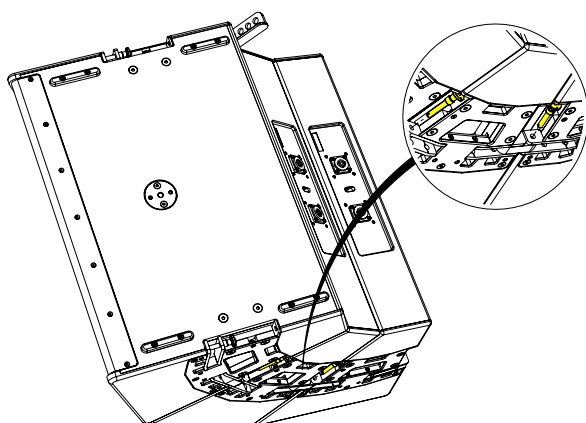

Up to 6 cabinets can be suspended using one of two T12HRIG's. Below shows the number of T12HIG for the array combination.

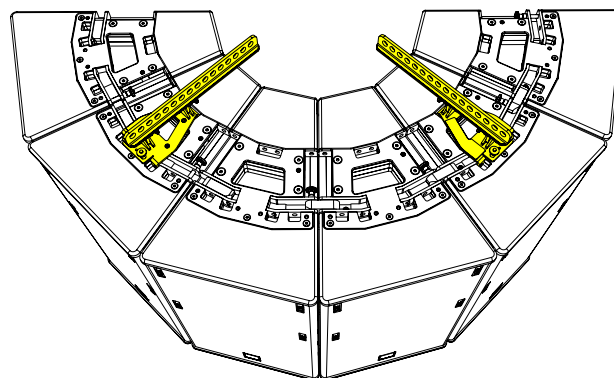
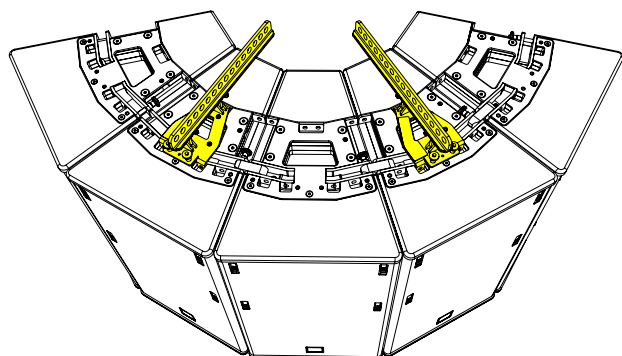
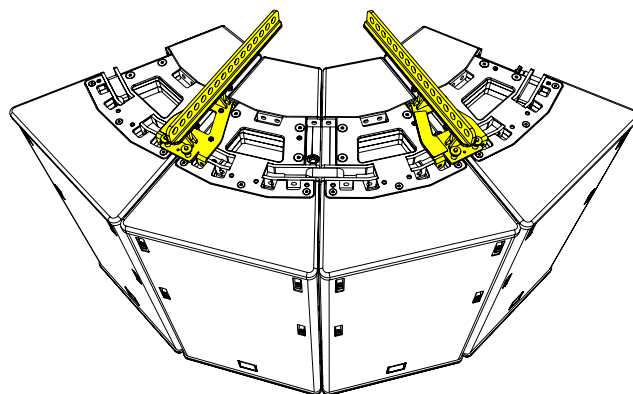
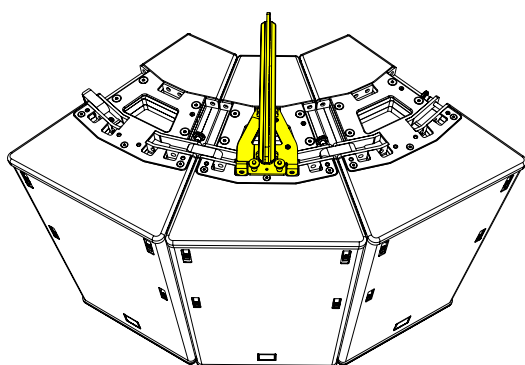
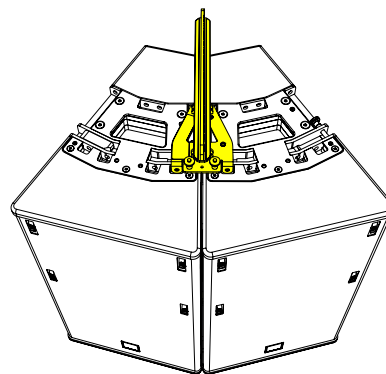
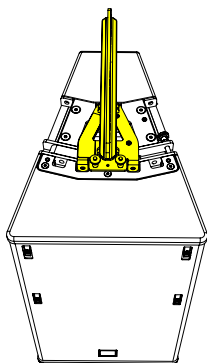

**T12TRIG**

The T12TRIG is a conversion frame for TORUS to be flown beneath SXCF118.

Using one or two motors position a WPSGRIDt above the SCXF118 and lower it onto the enclosure.

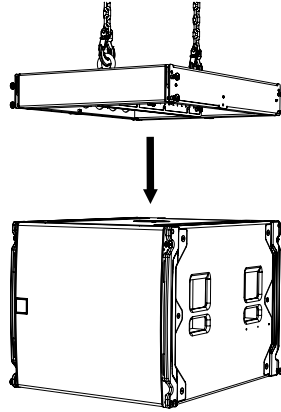

Remove the pins from the from SXCF118 to release the links. Rotate the SXCF118 links and line them up with the pin holes in the WPSGRIDt.

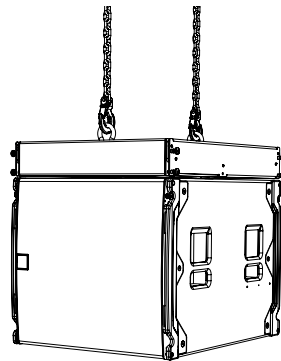

Replace the pins to link and lock the SXCF118 securely to the WPSGRIDt.

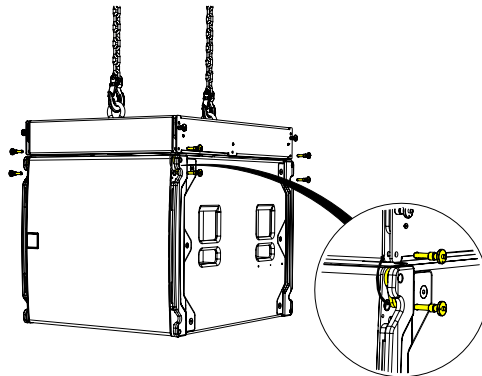

Raise the sub array and place the T12TRIG underneath. Lower the array making sure the T12TRIG is aligned.

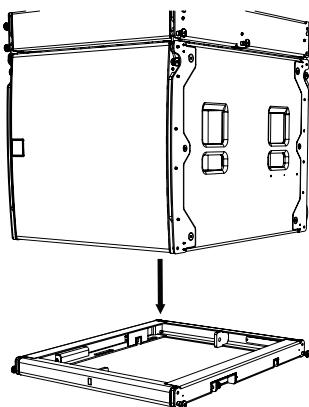

Remove the rigging pins from all four corners of the T12TRIG

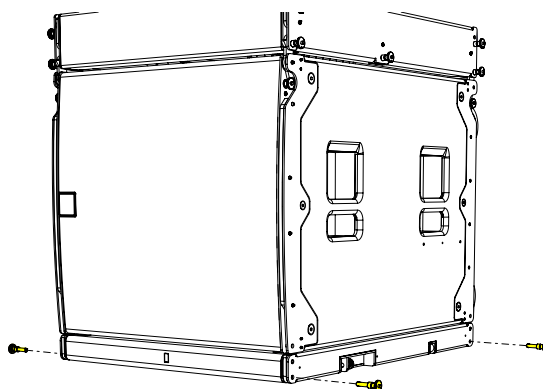

Rotate the four links on the T12TRIG and align them with the SXCF118 rigging hardware.

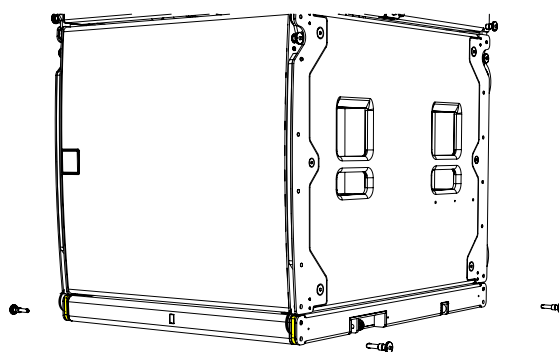

Insert the rigging pins from the T12TRIG to the bottom of the SXCF118.

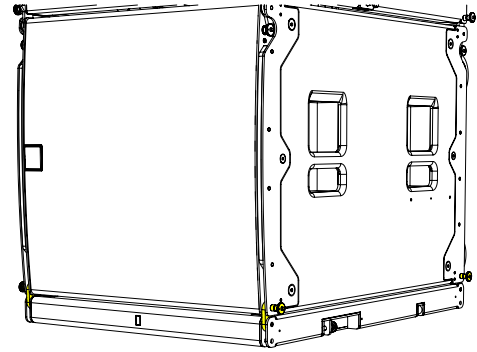
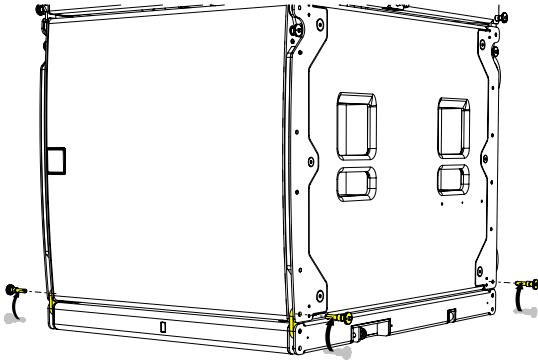

*HF Right*

Lift the array to a height where the cabinet can be positioned underneath. Either lift the cabinet into position or lower the array onto the cabinet below

Remove rigging pin from the T12TRIG and rotate the TORUS link through 180 degrees.

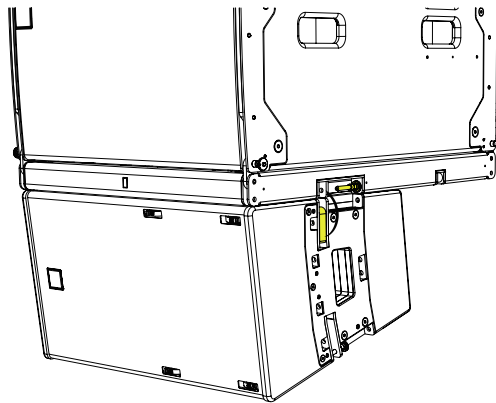

Replace the rigging pins to secure the cabinet to the T12TRIG.

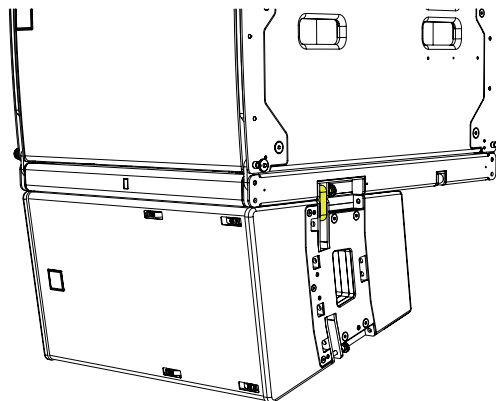



Lift the array to a height where the next cabinet can be positioned underneath. Either lift the cabinet into position or lower the array onto the cabinet below.

Remove the rigging pins from the cabinet above, rotate the links on the cabinet below and insert the rigging pins to secure.

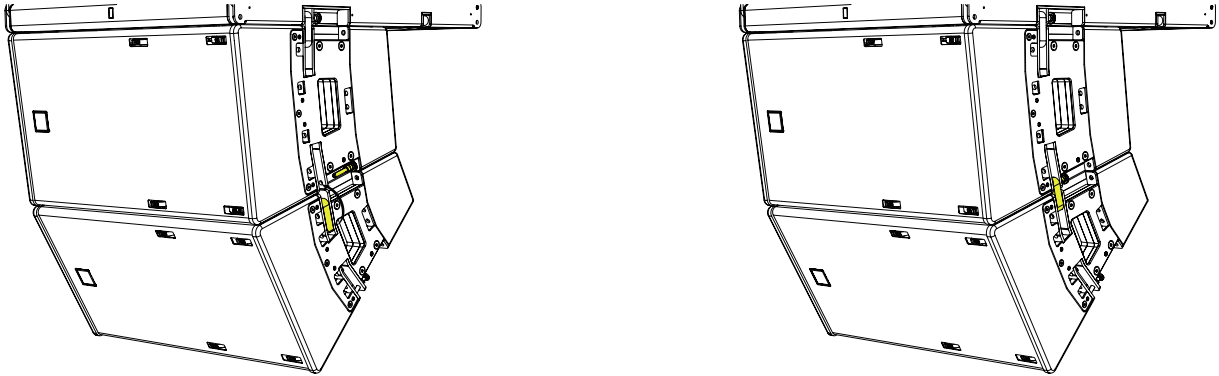

*HF Left*

Rotate the T12TRIG through 180 degrees and repeat the steps shown on page 35 to rig the T12TRIG beneath the SCXF118. Rotate the links on the T12TRIG

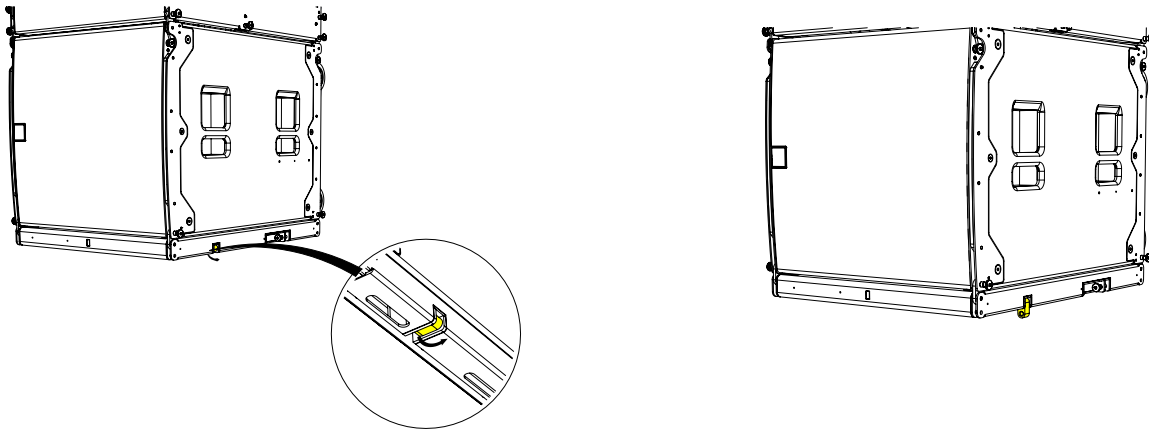

Lift the array to a height where the cabinet can be positioned underneath. Either lift the cabinet into position or lower the array onto the cabinet below and secure both side using the TORUS rigging pins.

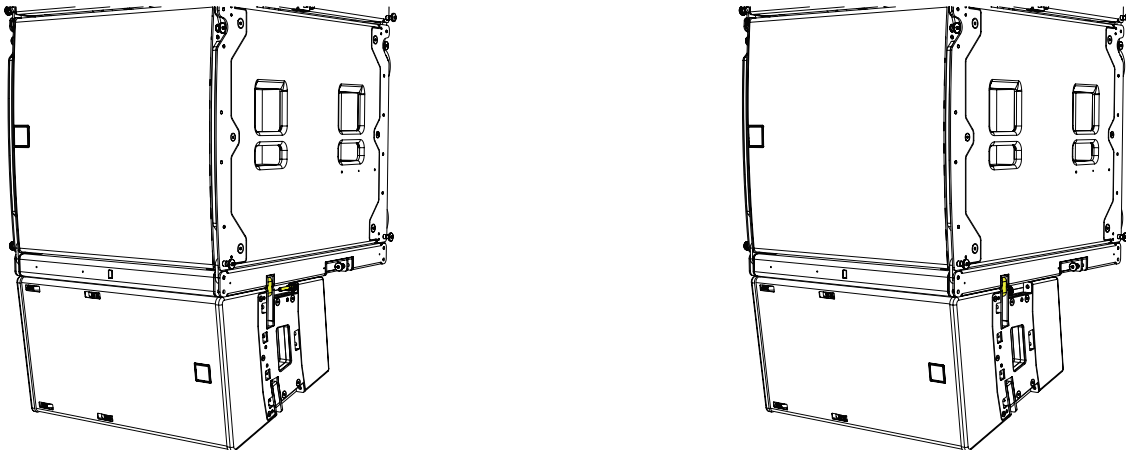

Lift the array to a height where the next cabinet can be positioned underneath. Either lift the cabinet into position or lower the array onto the cabinet below.

Remove the rigging pins from the cabinet below, rotate the links on the cabinet above and insert the rigging pins to secure.

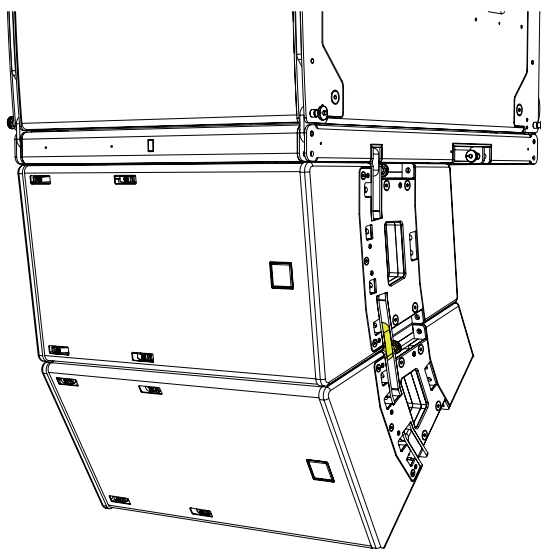
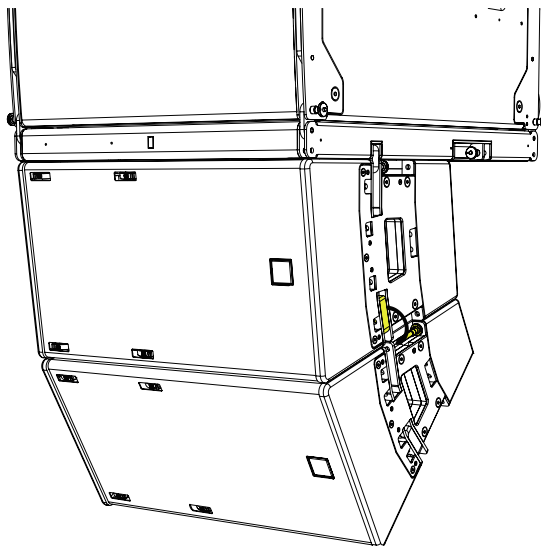

**T12PB**

A rigging bar that can be mounted at the top and the bottom of the array allows extreme array deployment for installations.

When flying TORUS vertically the HF horn can be positioned on the left or the right to create symmetrical system design.

*Linking down – HF horn to the left*

*Linking up – HF horn to the left*

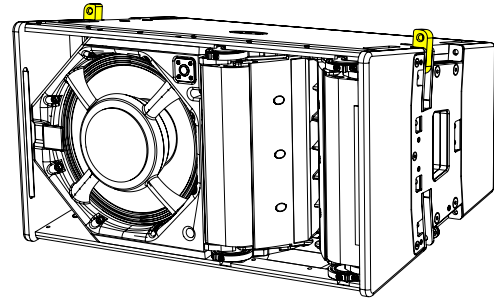
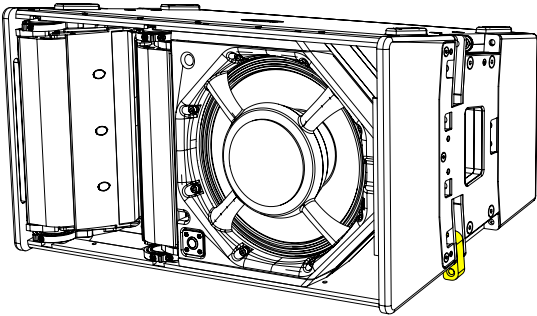

*HF Right*

Position the T12PB on top of the TORUS cabinet, rotate the links and insert the rigging pins to secure. Make sure the cabinet is secured on both sides.

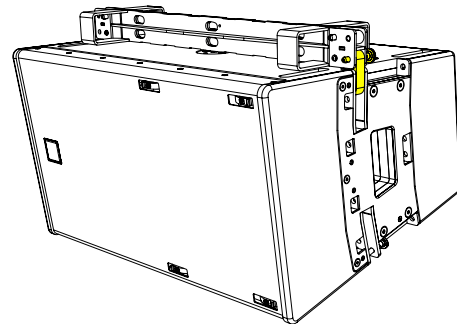
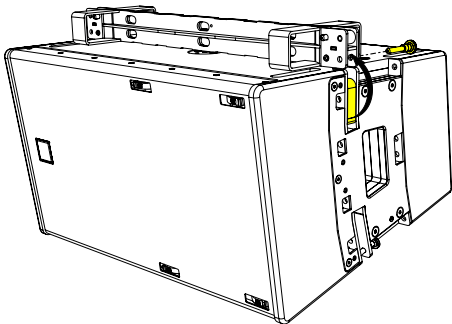

Lift the array to a height where the next cabinet can be positioned underneath. Either lift the cabinet into position or lower the T12PB onto the cabinet below.

Remove the rigging pins from the cabinet above, rotate the links on the cabinet below and insert the rigging pins to secure.

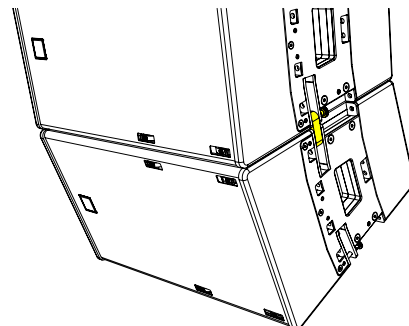
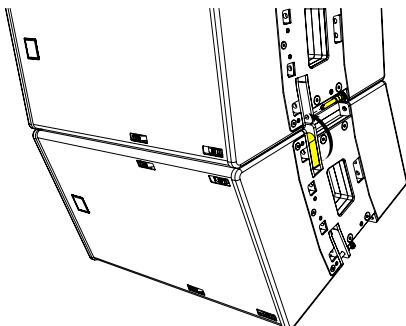

Repeat the process until the desired amount of TORUS have been vertically arrayed. A maximum of 6 cabinets can be flown from the T12PB.

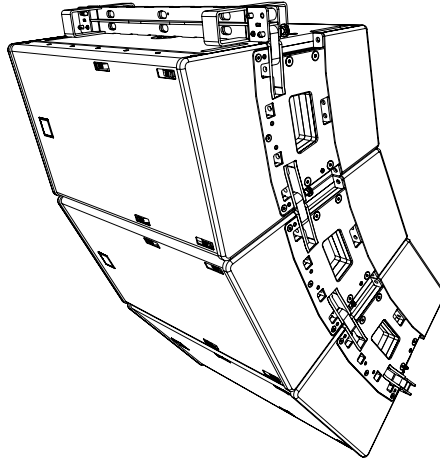

A second T12PB can be linked to the bottom of the array and used to achieve angles that are not possible with a single T12PB. The configuration can also be used to secure the array to stop it moving.

Invert the T12PB, remove the rigging pins and rotate the T12GRID links. Replace the pins to secure the grid to the cabinet.

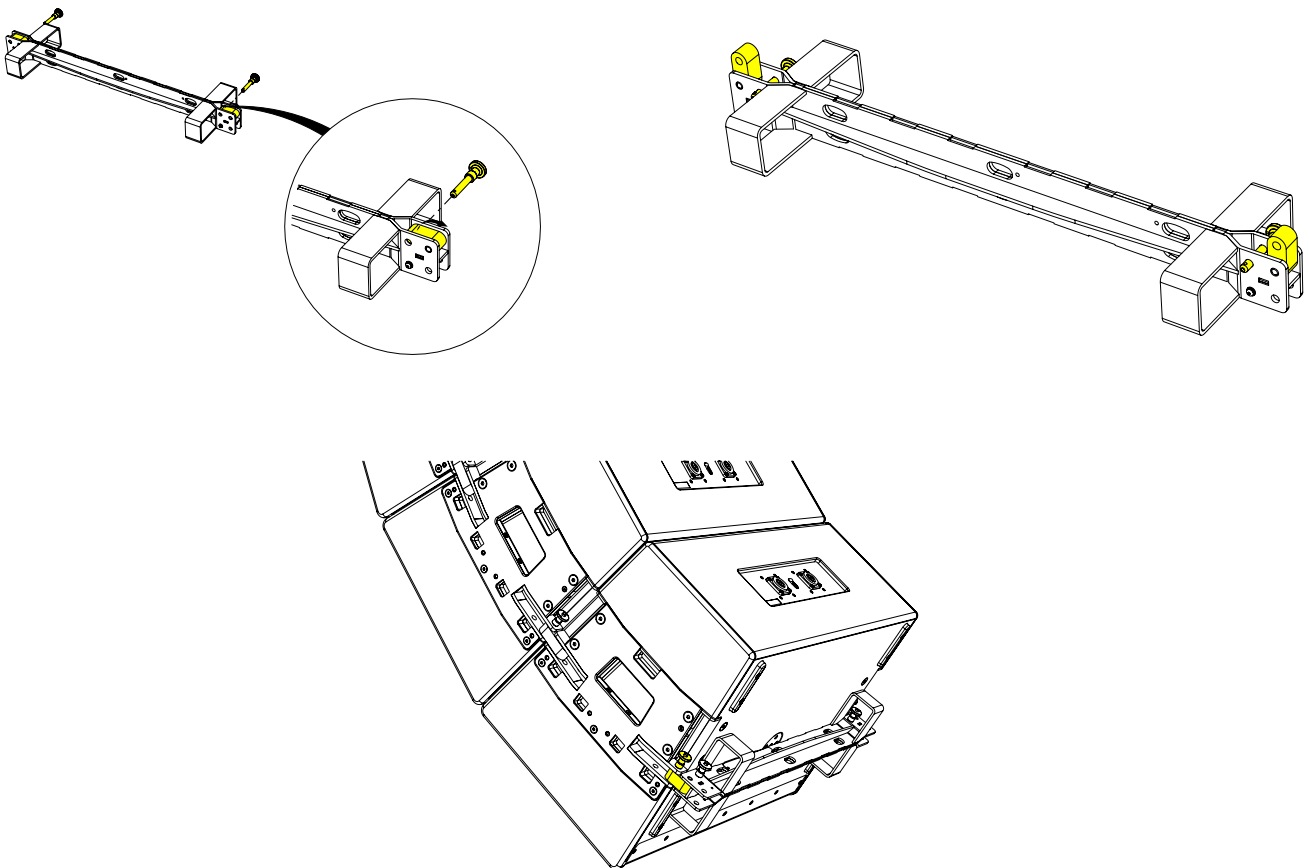

Note: The T12PB rigging pin is not used for this configuration but needs to be remove (then replaced) to rotate the link.

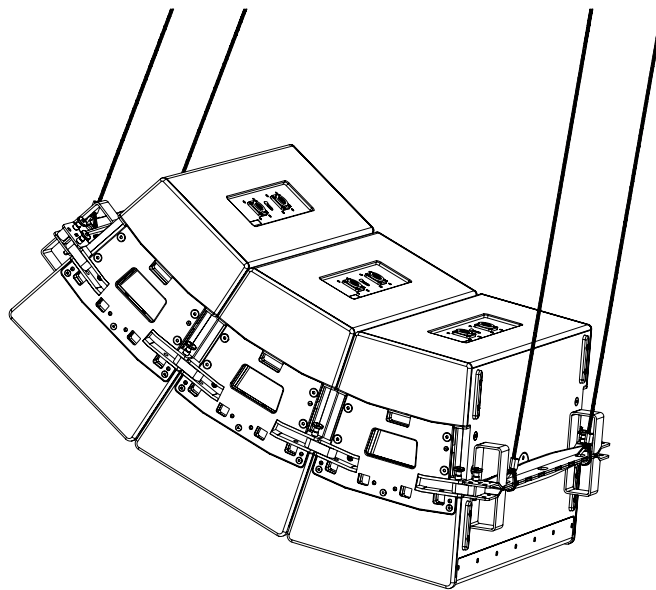

**T12POLERIG**

The vertical angle for a pole mounted TORUS can be adjusted and secured with a tethered pin. The tilt angle will differ depending on which TORUS cabinet is used. Angles for both T1215 and T1230 are clearly displayed on the hardware.

There are two mounting plates, one on either side of the cabinet. Decide which orientation you want the HF horn (left side or right side). Align the two pins and place the POLERIG onto the mounting bracket.

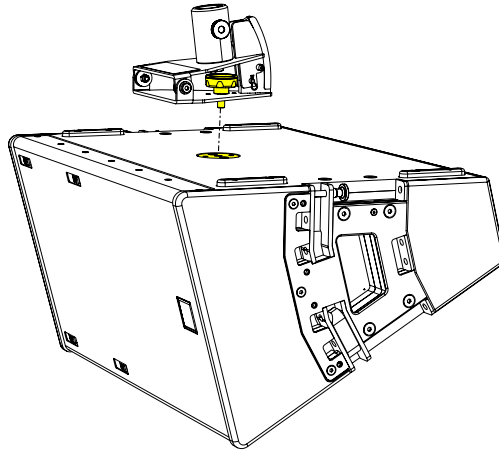

Turn the handwheel and tighten securely.

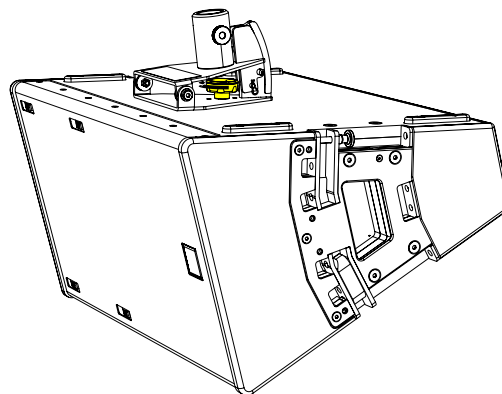

Before placing the cabinet onto a speaker stand or distance pole, undo the thumb wheel to on the pole adaptor.

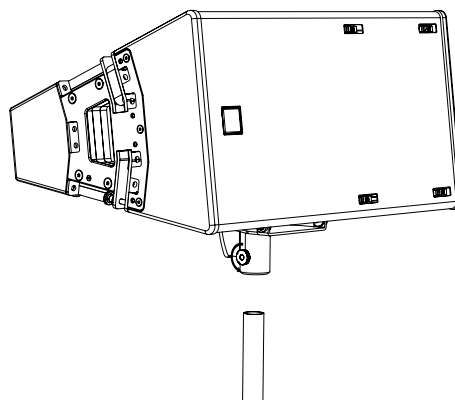

When mounted on the pole tighten the thumb wheel to secure the POLERIG to the speaker stand or distance pole and remove the index pin.

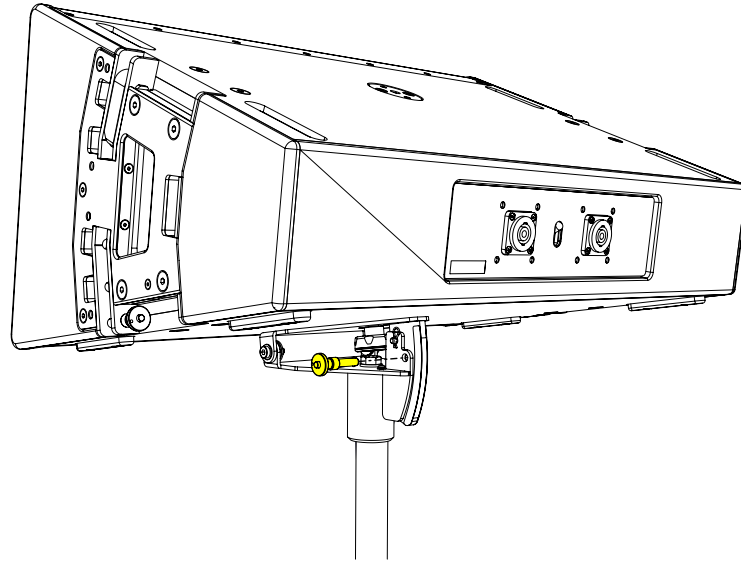

**SBAR**

The SBAR is a simple accessory allowing a single TORUS cabinet to be flown using 1 of 10 angles. The SBAR can be mounted front or back for up and down-tilt. Please refer to DISPLAY 3 for rigging options.

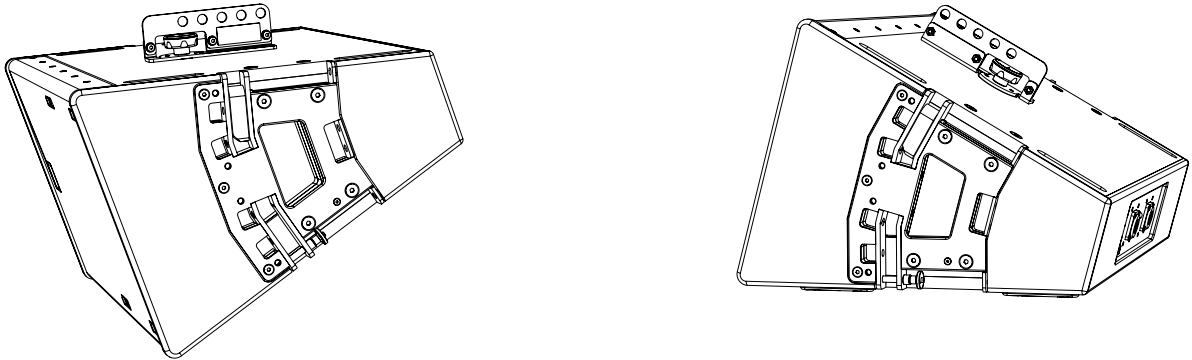

There are two mounting plates, one on either side of the cabinet. Decide which orientation you want the HF horn (left side or right side). Align the two pins and place the POLERIG onto the mounting bracket.

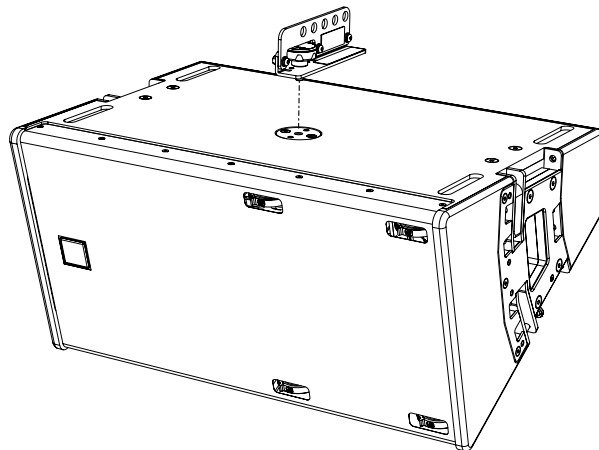

Turn the handwheel and tighten securely.

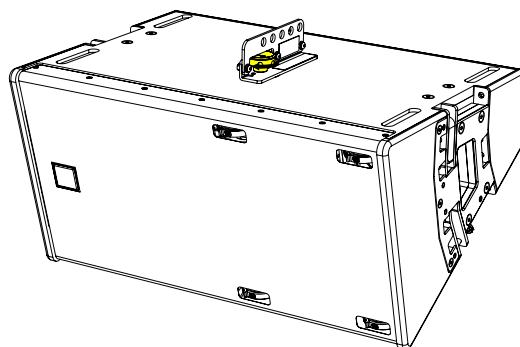



A half coupler adaptor can be used to suspend a single cabinet from the SBAR.

Secure the half coupler to the adaptor and remove the pin.



Secure the adaptor to the SBAR and replace the pin.

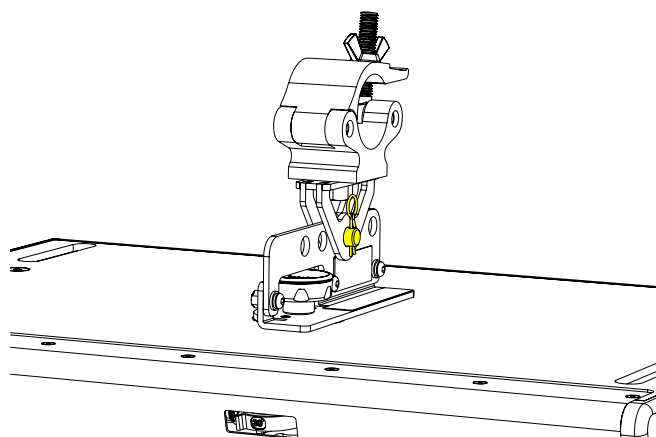

Secure the cabinet to the truss.

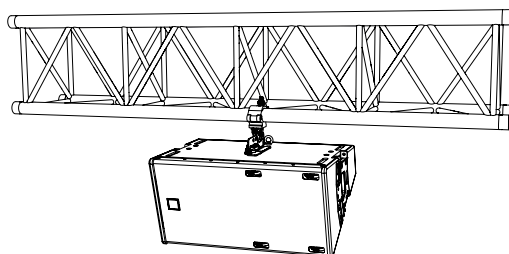

## Essential Maintenance

To perform maintenance on this product the following tools listed below are needed.

4mm hex tool

6mm hex tool

### Replacing the LF Driver

Remove the countersunk hex fasteners from the grille. (4mm hex tool)

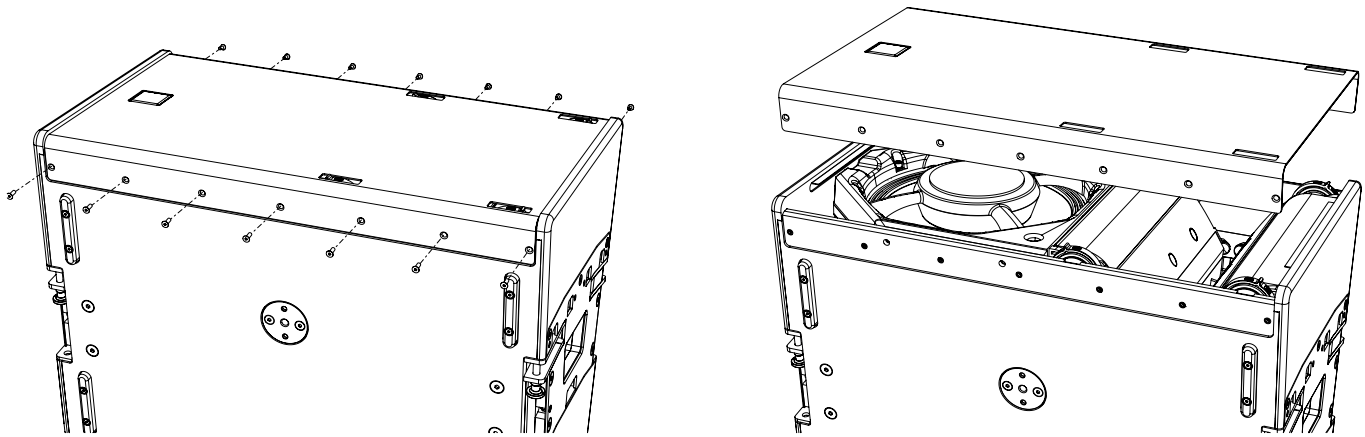

Remove the socket cap fasteners from the LF phase bung in a star pattern. There are 8 around the circumference of the driver and 2 on the side next to the HF horn. (6mm hex tool).

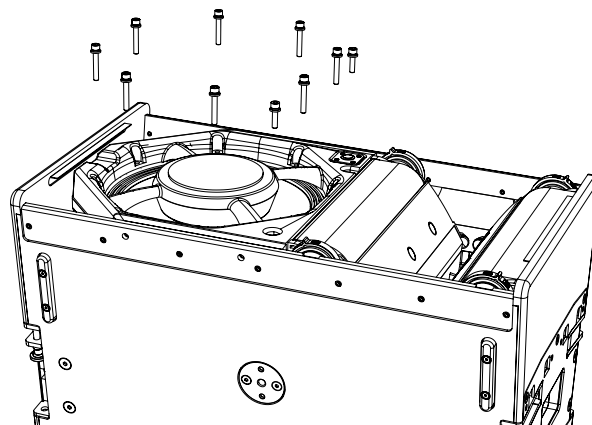

Remove the phase bung and disconnect the spade terminals for the LED if necessary.

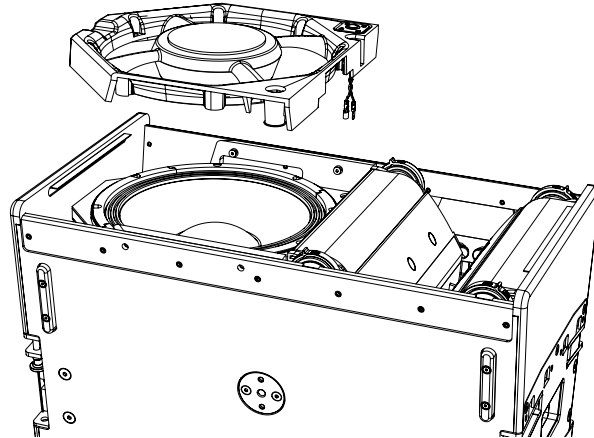

Remove the LF driver and disconnect the spade terminals.

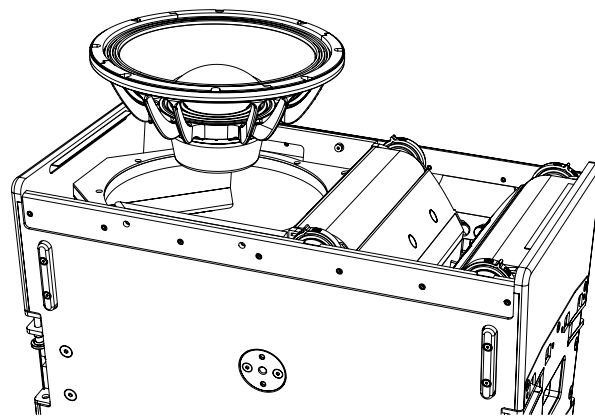

## Replacing the High Frequency Diaphragms

Remove the 6 rubber bungs from the horn flare

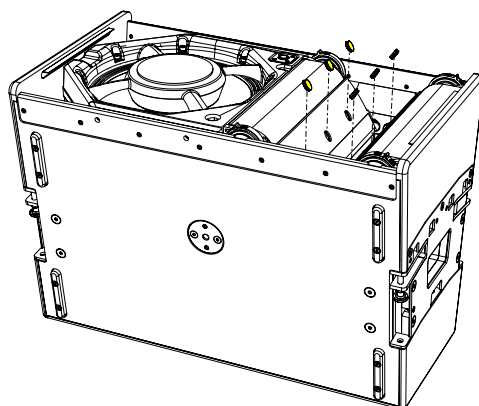

Remove the 6 posi drive screws from the horn flare.

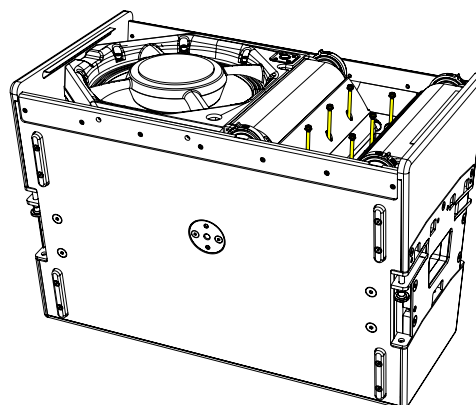
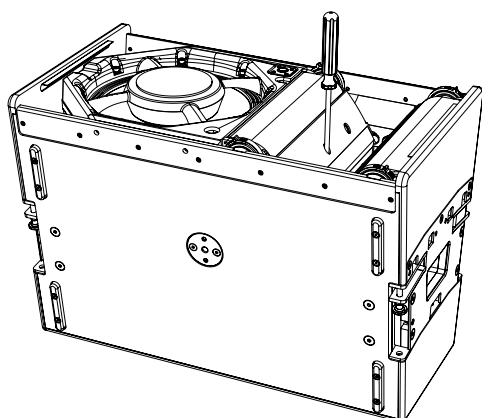

Remove the horn assembly from the cabinet and place driver side up on a flat surface.

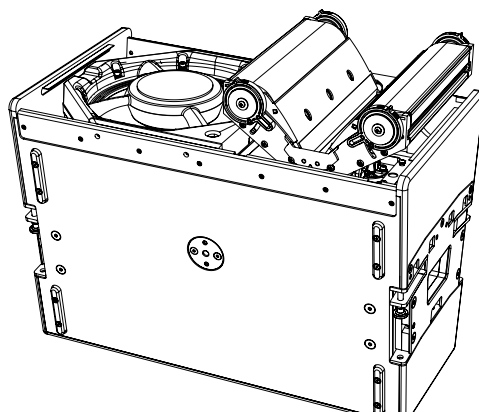

Remove the socket cap fasteners from the horn to remove the compression driver.

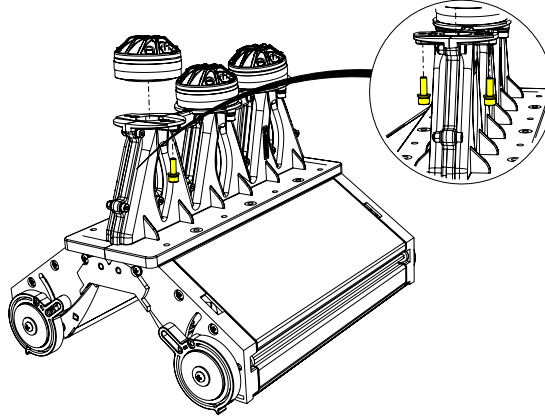

Remove the socket cap fasteners from the backplate to replace the diaphragm.

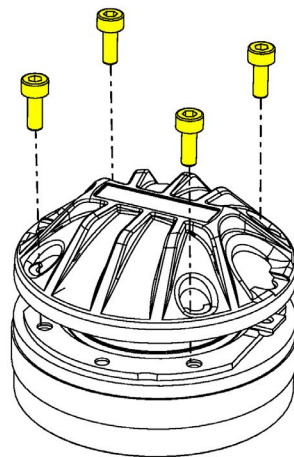

# Specifications

## T1215 and T1230

PRODUCT NAME	TORUS: T1215	TORUS: T1230
TYPE	Passive 2-way Constant Curvature 15° enclosure	Passive 2-way Constant Curvature 30° enclosure
FREQUENCY RESPONSE (with iKON settings)	65Hz – 18kHz ± 3dB, -10dB @ 50Hz	65Hz – 18kHz ± 3dB, -10dB @ 50Hz
DRIVERS	LF: 12", 3" Voice Coil, Neodymium HF: 3 x 1" exit, 1.4" Voice Coil, HT Polymer dome neodymium compression driver	LF: 12", 3" Voice Coil, Neodymium HF: 3 x 1" exit, 1.4" Voice Coil, HT Polymer dome neodymium compression driver
SENSITIVITY	(2.83V 1m free-field) 100dB	(2.83V 1m free-field) 99dB
NOMINAL IMPEDANCE	8 ohms	8 ohms
RATED POWER	AES 400W, PEAK 1600W	AES 400W, PEAK 1600W
MAXIMUM SPL (SYSTEM)	128dB continuous, 134 dB peak*	126dB continuous, 132dB peak*
DISPERSION	60-75-90° horizontal, 15° vertical	60-75-90° horizontal, 30° vertical
PIN CONNECTIONS (INPUT)	1+/- or 2+/-	1+/- or 2+/-
PIN CONNECTIONS (LINK)	1+/- and 2+/-	1+/- and 2+/-
DIMENSIONS	(W) 650mm, (H) 369mm, (D) 452mm (W) 25.59ins, (H) 14.51ins, (D) 17.80ins	(W) 650mm, (H) 350mm, (D) 442mm (W) 25.59ins, (H) 13.76ins, (D) 17.40ins
WEIGHT	31kg (68.34 lbs)	26kg (57.32 lbs)

\*Martin Audio continues to specify a crest factor of 2 with 6dB between peak and continuous which best mirrors real-world performance. Simply add a further 6dB for comparison with manufacturers quoting a crest factor of 4 ie. 12dB between continuous and peak.

# Technical Drawings

T1215

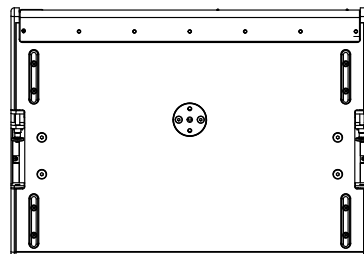
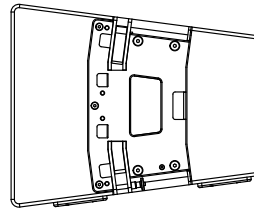
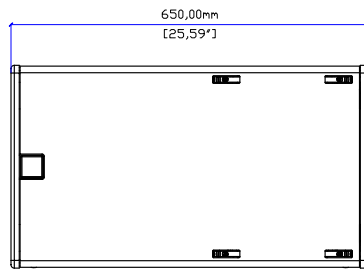
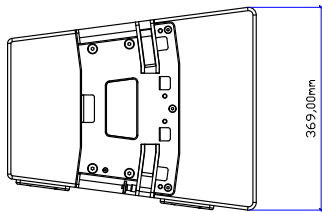
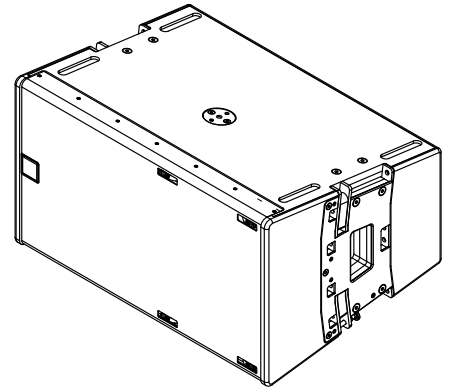
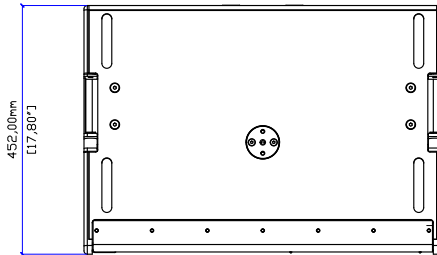

T1230

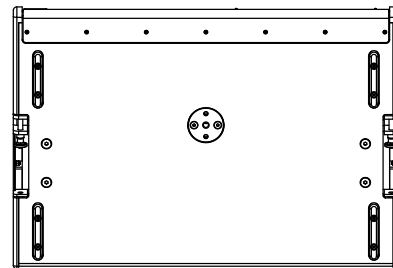
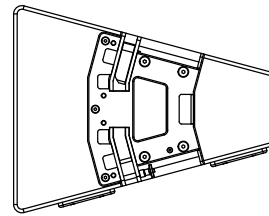
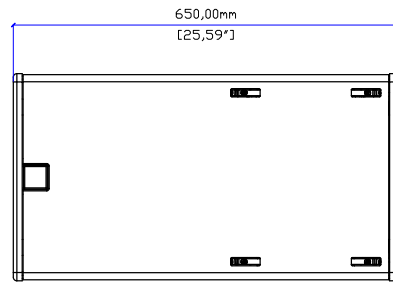
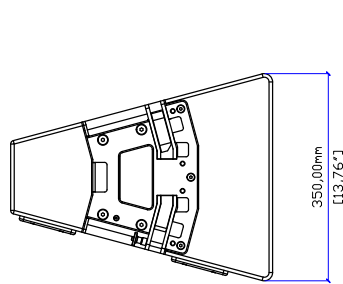
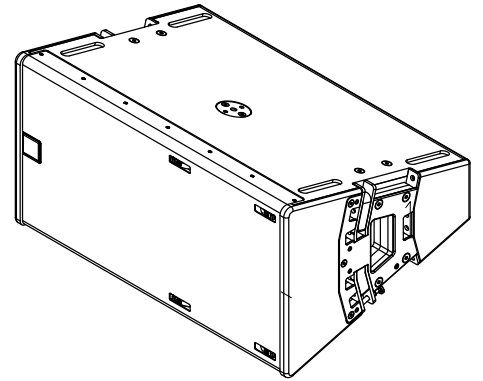
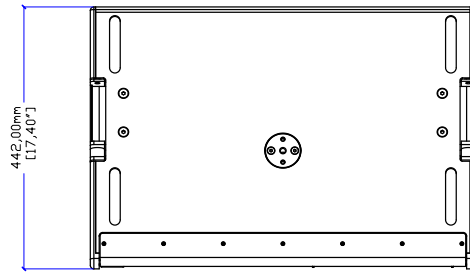



# Warranty

## Warranty Statement

Martin Audio TORUS Series loudspeakers are warranted against manufacturing defects in materials or craftsmanship over a period of 5 years from the date of original purchase.

During the warranty period Martin Audio will, at its discretion, either repair or replace products which prove to be defective provided that the product is returned in its original packaging, shipping prepaid, to an authorised Martin Audio service agent or distributor.

Martin Audio Ltd. cannot be held responsible for defects caused by unauthorised modifications, improper use, negligence, exposure to inclement weather conditions, act of God or accident, or any use of this product that is not in accordance with the instructions provided by Martin Audio. Martin Audio is not liable for consequential damages.

This warranty is exclusive and no other warranty is expressed or implied. This warranty does not affect your statutory rights.

**Martin Audio Limited**

Century Point

Halifax Road

Cressex Business Park

High Wycombe

Buckinghamshire

HP12 3SL

England

**FOR SALES ENQUIRIES:**

**UK**

Telephone: +44 (0)1494 535312

E-mail: [info@martin-audio.com](mailto:info@martin-audio.com)

**NORTH AMERICA**

Telephone: 323-381-5310

**[www.martin-audio.com](http://www.martin-audio.com)**

All information is Copyright © 2021 Martin Audio Ltd.

Martin Audio, the Martin Audio logo and Hybrid are registered trademarks of Martin Audio Ltd. in the United Kingdom, United States and other countries; all other Martin Audio trademarks are the property of Martin Audio Ltd.

