



CBT 70J-1

Constant Beamwidth Technology™
Two-Way Line Array Column with
Asymmetrical Vertical Coverage

CBT SERIES

CONSTANT BEAMWIDTH TECHNOLOGY™

Key Features:

- ▶ Asymmetrical vertical coverage sends more sound toward far area of room to make front-to-back sound levels more consistent.
- ▶ Components: Sixteen 25 mm (1 in) soft dome tweeters and four 125 mm (5 in) high-power LF drivers, arranged coaxially.
- ▶ Patent-pending Constant Beamwidth Technology™ provides constant directivity up to the highest frequencies and reduces out-of-coverage lobing.
- ▶ Vertical pattern coverage switchable between 45° for medium-throw coverage and 25° for long-throw applications.
- ▶ Switchable voicing provides flat response in music mode or mid-range presence peak in speech mode.
- ▶ Dynamic SonicGuard™ overload protection of HF devices
- ▶ Swivel (pan) / tilt wall bracket included.

Overview:

The CBT 70J-1, with Constant Beamwidth Technology™, represents a breakthrough in pattern control consistency, utilizing complex analog delay beam-forming and amplitude tapering to accomplish superior, consistent vertical coverage without the narrow vertical beaming and out-of-coverage lobing that are typical of straight form-factor column speakers.

The CBT 70J-1 combines Constant Beamwidth Technology with a physical J-shaped curving, resulting in a very well controlled progressive line array with asymmetrical vertical coverage. The asymmetrical coverage produces a higher concentration of sound with a tighter pattern from the upper half of the array and a lower concentration of sound with a broader vertical pattern from the lower half of the array. This sends more sound toward the far area of the room than to the near area of the room, resulting in more even front-to-back SPL levels than would be the case from a traditional speaker or column that projects symmetrically in the vertical plane.

The two-way coaxial design provides a wide 60 Hz – 20 kHz bandwidth. The low-diffraction baffle eliminates frequency response irregularities that could otherwise occur due to baffle discontinuities. The thick, heavy-duty aluminum grille stands up to portable/event applications while allowing for rust-free installation outdoors.

The slim, compact design fits well into virtually any architectural decor. The 70 cm (27.6 in) tall line array height provides consistent pattern control throughout the intelligibility band, making the CBT 70J-1 work well in difficult acoustic environments.

Applications

The combination of superior sound quality, excellent pattern control, asymmetrical vertical coverage and compact design makes CBT 70J-1 extremely versatile. It is ideal for applications such as performance auditoriums, lecture halls, classrooms, A/V, transit centers, school stadiums,



multipurpose spaces, racetracks, theme parks, and fill applications, among many others.

Adjustable Coverage to Fit the Application

The innovative coverage adjustability allows switching between broad and narrow vertical coverage settings to allow matching the coverage and throw requirements of the application. Coverage can be easily switched in-venue with the speaker already installed. This innovation allows a single loudspeaker model to excel in an extremely wide variety of project types.

User Variable Voicing

The voicing can be set to match the application through a Music/Speech switch. The Music setting provides flat frequency response, while the Speech setting produces a mid-range presence boost to provide clear, intelligible speech even at the longest throw distances, along with increased midrange sensitivity for higher midrange maximum output capability.

Drivers

The low frequency drivers are lightweight dual magnet neodymium motors with 38 mm (1.5 in) diameter voice coils. The dual magnet system provides maximum flux in a compact package. The magnet structure is magnetically shielded and the pole tips are magnetically saturated for lower flux modulation and minimum distortion. The 16 mm (0.63 in) long coil provides high linear drive and high power handling in a compact driver. The LF drivers feature damped blended textile surrounds and coated sealed paper cones found in high performance large format drivers.

The high frequency driver features a dual magnet neodymium structure for maximum sensitivity. The tweeter is encased for weather resistance. The drivers are magnetically shielded to allow close placement CRT monitors.

Both drivers feature coated diaphragm materials to provide moisture, UV and salt resistance for outdoor capability.

SonicGuard™

Dynamic SonicGuard™ protection on the high frequency section minimizes distortion at high drive levels by limiting driver excursion dynamically. This maximizes music clarity and speech intelligibility at high drive levels while protecting the drivers from damage due to occasional overpowering.

Bracketry

A swivel (pan) / tilt wall-mount bracket is included, plus ten M6 inserts on the back panel fit the spacing of common third-party mounting brackets, or can be utilized to suspend the speaker using forged shoulder steel eyebolts or swivel mounting rings, providing installation versatility.

CBT 70J-1 can be installed either indoors or outdoors. The drivers are weather-treated, the fiberglass reinforced ABS cabinet is excellent for outdoor applications, external screws are stainless steel and the painted aluminum grille resists rusting in the harshest conditions. Available in black or white (-WH).

CBT 70J-1 Two-Way Line Array Column with Asymmetrical Vertical Coverage

Specifications:

System:

Components:	Four 130 mm (5 in) LF drivers Sixteen 25 mm (1 in) HF drivers
Frequency Range (-10 dB) ¹ :	60 Hz – 20 kHz
Coverage:	Vertical (selectable via switch) Narrow Mode: 25° (2 kHz - 16 kHz) (±10°) Broad Mode: 45° (750 Hz - 16 kHz) (±10°) Horizontal 150° (500 Hz – 8 kHz, ±20°)
Sensitivity (2.83V@ 1m) ¹ :	Narrow: (speech mode) 98 dB (1 kHz - 8 kHz) (music mode) 93 dB (300 Hz - 18 kHz) Broad: (speech mode) 96 dB (1 kHz - 8 kHz) (music mode) 92 dB (300 Hz - 18 kHz)
Nominal Impedance:	8 ohms
Power Capacity ² :	500 W (2000 W peak), 2 hrs 350 W (1400 W peak), 100 hrs
Max SPL ³ :	Narrow: (speech mode) 125 dB cont ave (131 peak) (music mode) 120 dB cont ave (126 peak) Broad: (speech mode) 123 dB cont ave (129 peak) (music mode) 119 dB cont ave (125 peak)

Transducers:

Low Frequency Drivers:	4 pcs, 130 mm (5 in) drivers, dual magnet neodymium, 38 mm (1.5 in) voice coil, damped blended textile surround, coated diaphragm for moisture, UV, and salt resistance, shielded.
High Frequency Drivers:	16 pcs, 25 mm (1 in) drivers, dual magnet neodymium, encased magnet and coated diaphragm for moisture, UV and salt resistance, shielded.

Enclosure:

Enclosure:	Fiberglass reinforced ABS cabinet, painted aluminum grille
Outdoor Capability:	IP-54 rated, per IEC529. UV, moisture and salt-spray resistant.
Colors:	Black or white (-WH)
Insert Points:	10 M6 swivel (pan)/tilt (16 mm deep) insert points on back panel.
Mounting:	Included swivel (pan)/tilt wall bracket provides continuously variable +/-80 degree left-right swivel aiming (at no up/down tilt – see Bracket Guide for maximum swivel range at various up/down tilt angles), continuously variable +/-15 degree tilt, as well as 5 degree fixed increment points. Ten threaded mounting points located on back panel of cabinet conform to industry standard rectangular 127 x 70 mm (5.0 x 2.75 in) pattern for OmniMount® 60.0 and other compatible third-party brackets. Threaded mounting points can be utilized for suspension.
Dimensions (H x W x D):	694 x 170 x 237 mm (27.4 x 6.7 x 9.3 in)
Net Weight:	9.5 kg (21 lb)
Included Accessories:	Swivel (pan) / tilt wall bracket
Optional Accessories:	MTC-PC2 terminal panel cover MTC-CBT-SMB1 Stand-Mount Bracket for use with 35 mm heavy duty speaker stand MTC-CBT-FM2 flush-mount low-profile wall-mount bracket

¹Full space

²IEC standard, full bandwidth pink noise with 6 dB crest factor.

³Calculated based on power rating and measured sensitivity, exclusive of power compression.

JBL continually engages in research related to product improvement.

Changes introduced into existing products without notice are an expression of that philosophy.

CBT 70J-1 Two-Way Line Array Column with Asymmetrical Vertical Coverage

Broad Setting

Narrow Setting

Horizontal 1/3 Octave Polars

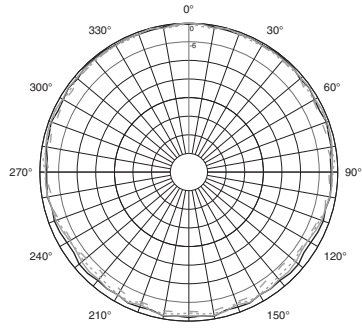

— 200 Hz
— 250 Hz
- - - 315 Hz
- - - 400 Hz

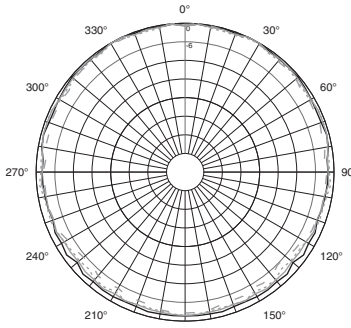

— 200 Hz
— 250 Hz
- - - 315 Hz
- - - 400 Hz

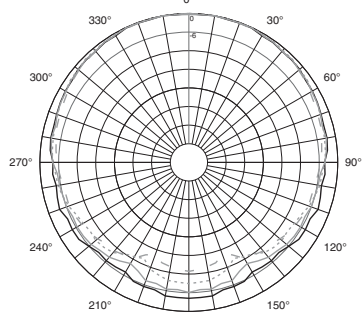

— 500 Hz
— 630 Hz
- - - 800 Hz
- - - 1 kHz

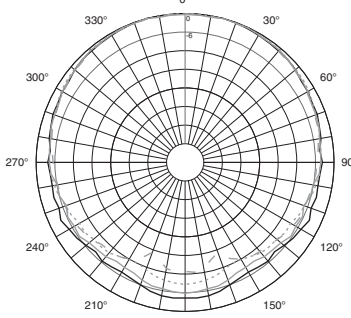

— 500 Hz
— 630 Hz
- - - 800 Hz
- - - 1 kHz

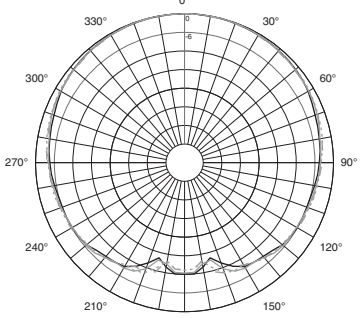

— 1.25 kHz
— 1.6 kHz
- - - 2 kHz
- - - 2.5 kHz

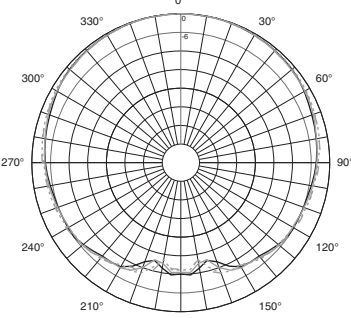

— 1.25 kHz
— 1.6 kHz
- - - 2 kHz
- - - 2.5 kHz

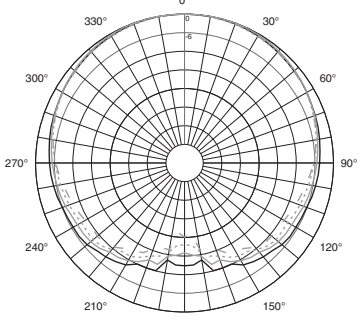

— 3.15 kHz
— 4 kHz
- - - 5 kHz
- - - 6.3 kHz

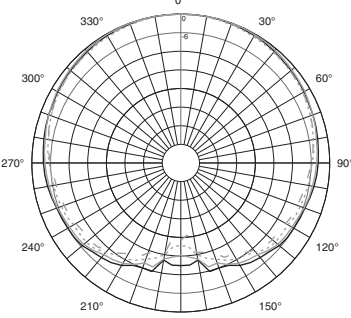

— 3.15 kHz
— 4 kHz
- - - 5 kHz
- - - 6.3 kHz

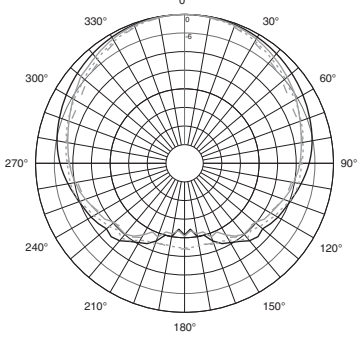

— 8 kHz
— 10 kHz
- - - 12.5 kHz
- - - 16 kHz

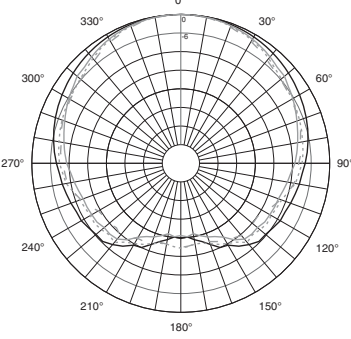

— 8 kHz
— 10 kHz
- - - 12.5 kHz
- - - 16 kHz

Broad Setting

Narrow Setting

Vertical 1/3 Octave Polars

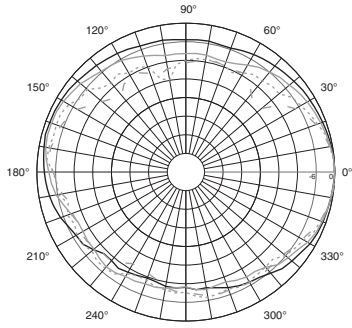

- 200 Hz
- 250 Hz
- 315 Hz
- - - 400 Hz

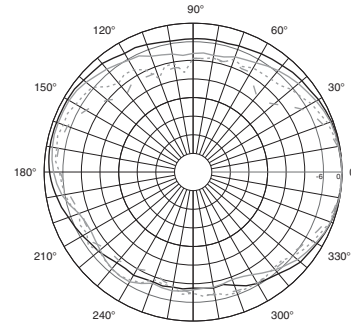

- 200 Hz
- 250 Hz
- 315 Hz
- - - 400 Hz

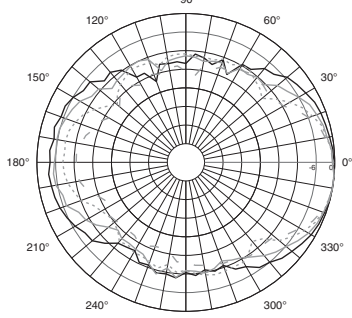

- 500 Hz
- 630 Hz
- 800 Hz
- - - 1 kHz

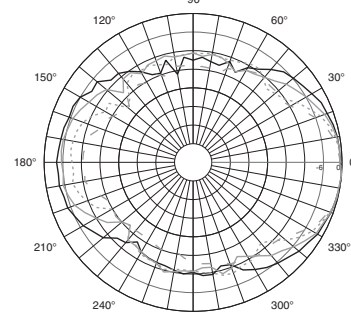

- 500 Hz
- 630 Hz
- 800 Hz
- - - 1 kHz

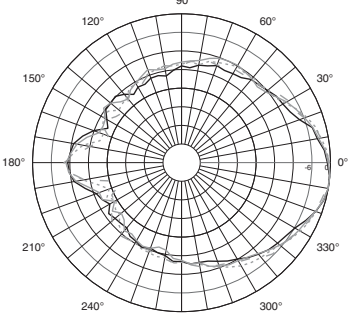

- 1.25 kHz
- 1.6 kHz
- 2 kHz
- - - 2.5 kHz

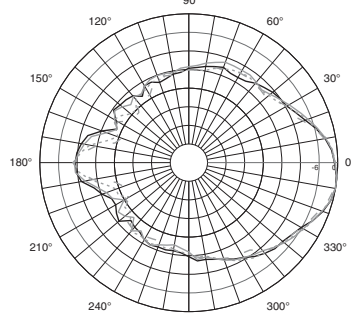

- 1.25 kHz
- 1.6 kHz
- 2 kHz
- - - 2.5 kHz

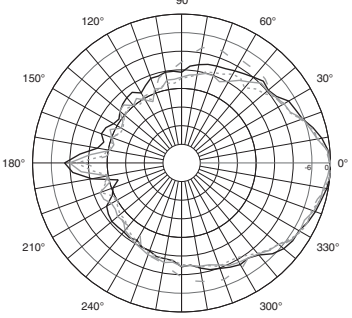

- 3.15 kHz
- 4 kHz
- 5 kHz
- - - 6.3 kHz

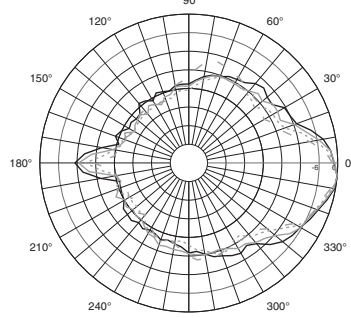

- 3.15 kHz
- 4 kHz
- 5 kHz
- - - 6.3 kHz

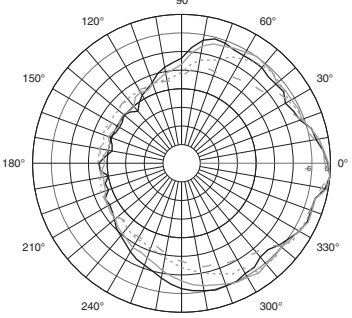

- 8 kHz
- 10 kHz
- 12.5 kHz
- - - 16 kHz

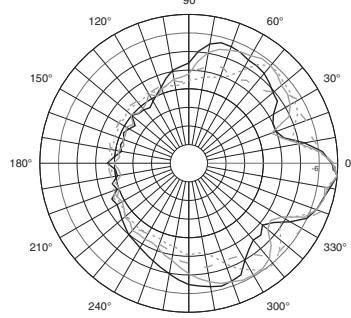

- 8 kHz
- 10 kHz
- 12.5 kHz
- - - 16 kHz

CBT 70J-1 Two-Way Line Array Column with Asymmetrical Vertical Coverage

Broad Setting

Frequency Response:

“Music” Mode (solid); “Speech” Mode (dotted), 1W (2.83V), 1m, and Impedance

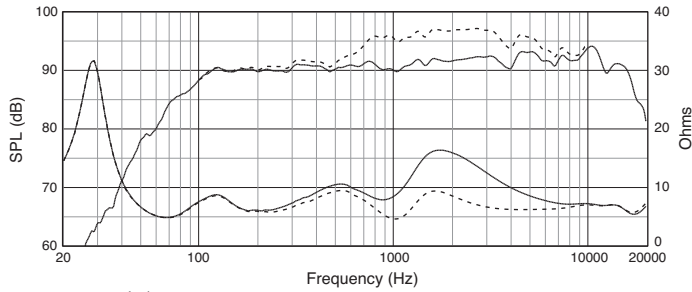

Beamwidth:

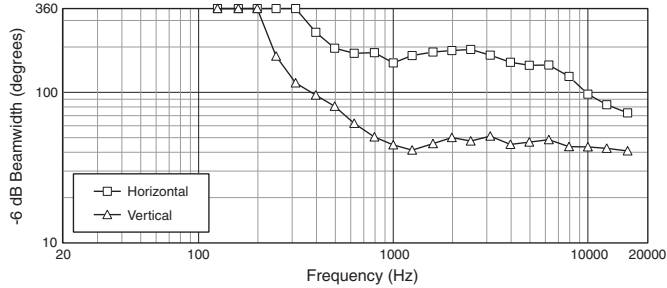

Directivity, Q

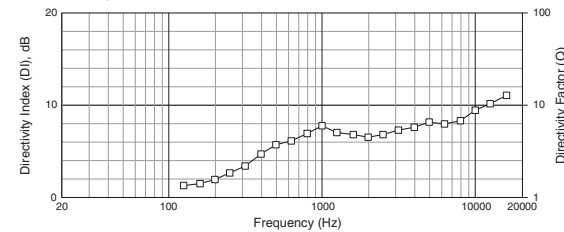

Vertical Off-Axis Frequency Response, Up

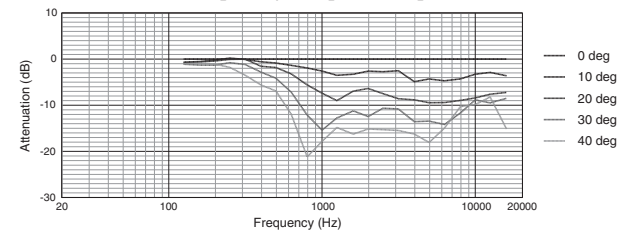

Vertical Off-Axis Frequency Response, Down

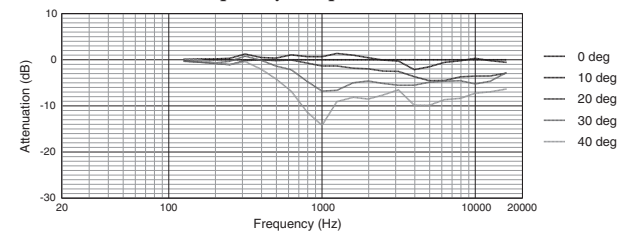

Horizontal Off-Axis Frequency Response

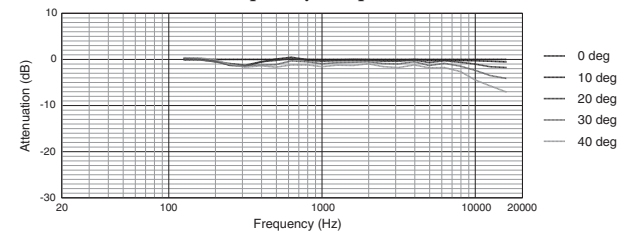

Narrow Setting

Frequency Response:

“Music” Mode (solid); “Speech” Mode (dotted), 1W (2.83V), 1m, and Impedance

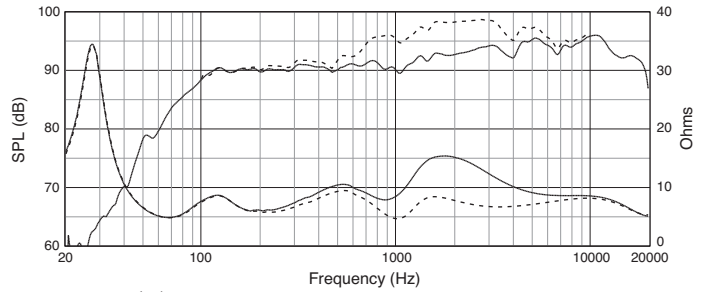

Beamwidth:

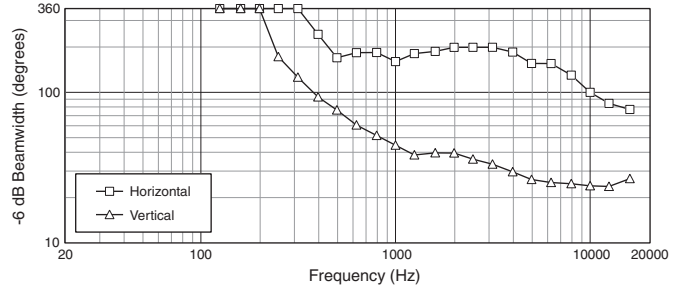

Directivity, Q

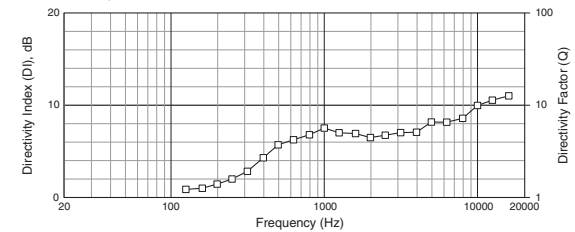

Vertical Off-Axis Frequency Response, Up

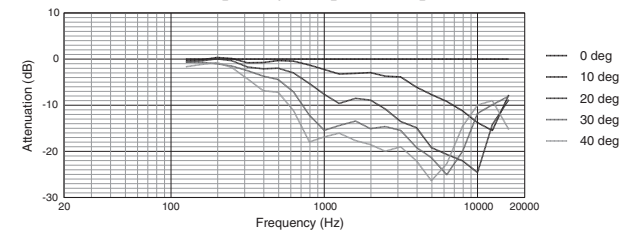

Vertical Off-Axis Frequency Response, Down

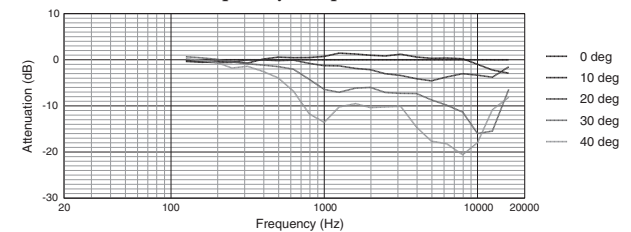

Horizontal Off-Axis Frequency Response

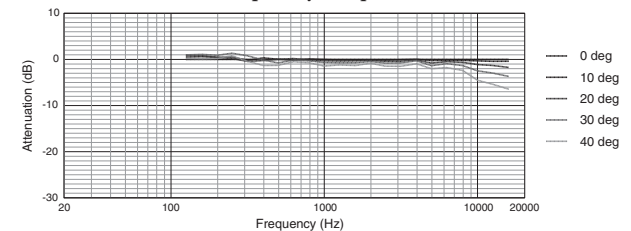

CBT 70J-1 Two-Way Line Array Column with Asymmetrical Vertical Coverage

Dimensions:

Dimensions in mm [in]

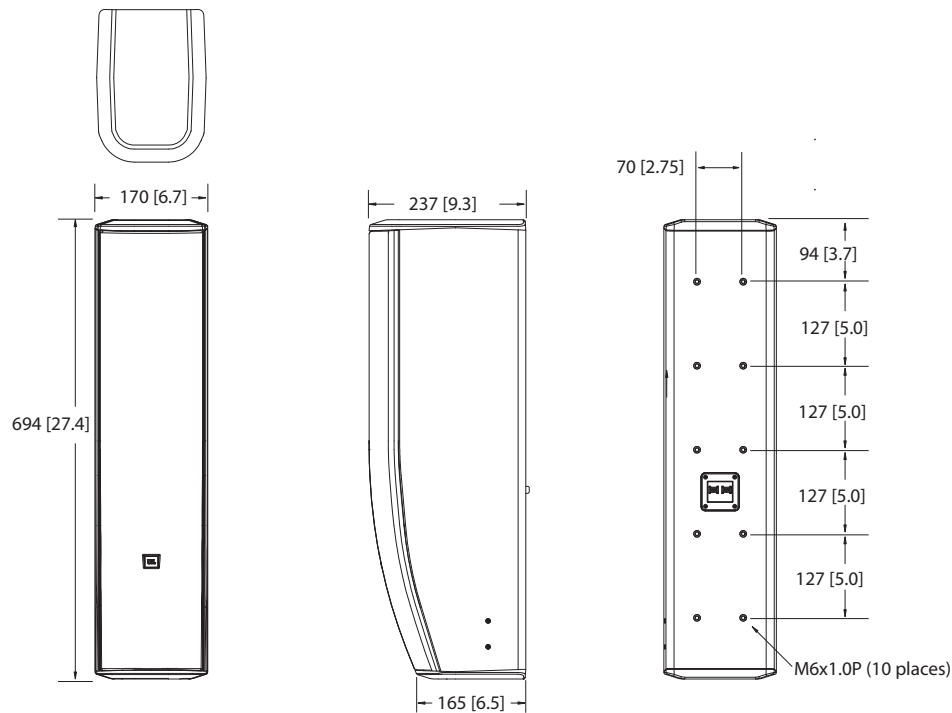

Wall Bracket

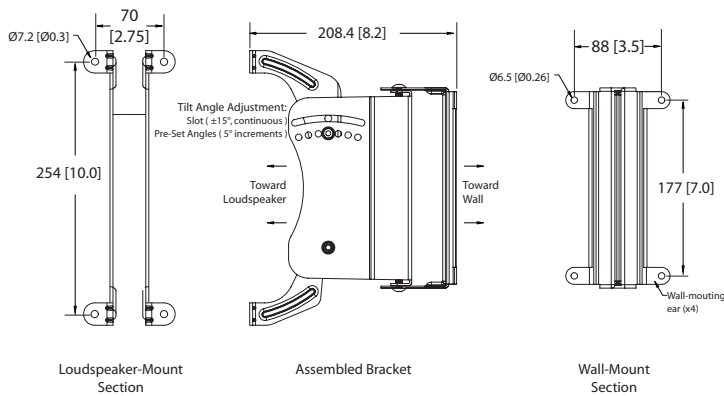

JBL Professional
8500 Balboa Boulevard, P.O. Box 2200
Northridge, California 91329 U.S.A.

© Copyright 2011 JBL Professional
www.jblpro.com

SSCBT70J-1
04/11