

# **Model 5422A**

## **Dante® Intercom Audio Engine**

### **User Guide**

Issue 1, September 2021

This User Guide is applicable for serial numbers  
M5422A-01001 and later with Main Firmware 1.00 and later

**Copyright © 2021 by Studio Technologies, Inc., all rights reserved**  
studio-tech.com

This page intentionally left blank.

## Table of Contents

Revision History .....	4
Introduction .....	5
Installation .....	8
Dante Configuration .....	10
Model 5422A Configuration .....	12
Operation .....	36
Technical Notes .....	41
Specifications .....	44
Appendix A–Network Configuration Examples .....	46
Appendix B–Dante Controller Network Default Configuration Values .....	49
Appendix C–Front-Panel Menu Structure .....	50
Appendix D–Model 5422A Default Configuration Values .....	51
Appendix E–Accessing the Unit when User Name and/or Password Not Known .....	52

## Revision History

### Issue 1, September 2021:

- Initial release.

## Introduction

The Model 5422A Dante Intercom Audio Engine is a high-performance, cost-effective, and flexible solution for creating party-line (PL) intercom circuits when used with Dante-compatible products. These include the Studio Technologies' range of 1-, 2-, and 4-channel intercom belt packs. The Model 5422A will also prove value in a variety of other general audio and broadcast-related mixing, IFB (talent cueing), and interfacing applications. The unit is suitable for use in fixed and mobile broadcast facilities, post-production studios, commercial and educational theater environments, and entertainment applications. Only power and Ethernet network connections are required for the Model 5422A to provide a powerful resource in a variety of Dante applications. The Model 5422A is available in two versions — one with 32 input and output channels and the other with 64 input and output channels.

The Model 5422A provides three Gigabit Ethernet (GigE) network interfaces, two which can support redundant Dante operation and a third for accessing the management menu system. To meet the latest interoperability standard the unit's Dante implementation meets the requirements of AES67. Support for the Dante Domain Manager™ (DDM) software application is also provided. An integral web server allows fast and flexible configuration of the unit's audio, networking, and Dante performance. Front-panel indicators, a graphics display, and pushbutton switches provide personnel with direct access to key operating parameters. The Model 5422A can be powered by 100-240 V, 50/60 Hz mains or a source of 12 volts DC. The lightweight enclosure mounts in one space (1U) of a standard 19-inch rack.

## Applications

The Model 5422A is compatible with many Dante-compliant devices including the extensive range of intercom belt packs from Studio Technologies. These include the single-channel/dual-listen Model 372A and Model 373A, the 2-channel Model 370A and Model 371A, and the 4-channel Model 374A. The Model 5422A will also function directly with

other Dante-supporting devices such as the Model 348 Intercom Station, Model 5304 Intercom Station, and Model 391 Dante Alerting Unit. In addition, the Model 5422A can function with matrix intercom systems, audio consoles, and wireless intercom base stations.

## Pro Audio Quality and Auto Mix

The Model 5422A supports 48 kHz sampling rate digital audio signals that interface using Dante. The unit's audio circuitry was designed to meet the demands of professional audio applications, far exceeding the sonic quality of "typical" intercom products. A bit depth of up to 32 is supported and all audio processing is performed using high-speed 32-bit programmable logic. This ensures that the audio performance is excellent, providing the expected benefits of minimal distortion, low noise, high headroom, flat frequency response, and extremely low latency.

The Model 5422A's Auto Mix function utilizes a sophisticated FPGA-based algorithm to provide enhanced audio intelligibility. This feature is unique to party-line (PL) intercom applications and offers users the opportunity to obtain the absolutely finest audio performance. Studio Technologies is confident that the Model 5422A's Auto Mix capability will meet or exceed the automatic mixer performance of virtually all other hardware- or software-based devices.

## Two Versions

Two versions of the Model 5422A are available. The Model 5422A-01 provides one 32-channel audio engine. The Model 5422A-02 provides two 32-channel audio engines for a total of 64 input and output channels. The size and scope of a specific application will dictate which Model 5422A version is applicable. The term "audio engine" was selected to describe a set of audio input, processing, routing, and output resources that can be configured to support specific intercom, talent-cueing, and audio routing and control functions. Unlike general-purpose digital matrix devices, the Model 5422A is optimized to allow direct support for these special broadcast and general-intercom applications.



**Figure 1. Model 5422A Dante Intercom Audio Engine front and back views (back panel typical for Model 5422A-02)**

## Group Configuration

Configuration choices select how each 32-channel audio engine is segmented, labeled (named), and optimized for how the associated audio signals are processed.

### Group Size

The ability to segment a 32-channel audio engine into multiple groups allows efficient use of the Model 5422A's Dante channels. As all Dante intercom beltpacks are essentially 4-wire devices (having independent receiver (input) and transmitter (output) channels) "virtual" (simulated) party-line functionality must be created within the Model 5422A's audio engine(s). This requires that the maximum number of participants (users) on any one "party-line" be defined.

The 32 channels offered by an audio engine can be configured into what are called groups. Simple configuration choices in the Model 5422A's menu pages allow the number of groups and their sizes to be selected. Groups can range in size from 32 channels (a complete audio engine being used for a single group) to having just four channels. The size of a group will dictate how many devices and associated users can be part of any one party-line or how many channels will be impacted by a processing setting for a specific group. Ten choices allow a wide range of group configurations to be selected. The default setting for each audio engine is to have four 8-channel groups. This leads to the Model 5422A-01 having four 8-channel groups and the Model 5422A-02 having eight 8-channel groups. Refer to the Specifications section for a detailed list of the group sizes that are available.

### Group Labels

Each group can be assigned a unique label. These labels would typically reflect how the specific groups are going to be utilized. Labels such as Camera PL, Lighting, Pyro, or Engineering would be typically used in broadcast- or live-event-oriented intercom applications. The configured labels are automatically used by the Model 5422A's Dante Interface, providing clarity when routing Dante channels using applications such as Dante Controller. Each group label can be a combination of up to 14 alpha or numeric characters. Channel numbers are automatically appended to the entered labels to provide identification of the specific channels within the Dante environment. A label of up to 12 additional characters can also be added to each specific channel, providing further details about an application.

## Group Operating Modes

While the primary application for the Model 5422A is to create party-line (PL) intercom circuits, each group can be independently configured from among seven operating modes: Party-Line w/Auto Mix, Party-Line, Summing Bus w/Auto Mix, Summing Bus, Pass-Thru, IFB, and Audio Switching.

### Party-Line

When a group is configured for Party-Line w/Auto Mix or Party-Line operating mode the Model 5422A's audio processing circuitry creates a series of independent "mix-minus" outputs, one for each channel in the group. These specialized outputs allow each intercom user assigned to that specific group (a "party-line") to hear all members of that group except for themselves. (This is the origin of the term mix-minus and indicates a mix of all sources but themselves.) By each user receiving a mix-minus signal precise control of each user's sidetone audio level and overall audio quality can be maintained. The Party-Line w/Auto Mix operating mode offers Model 5422A users a level of audio performance that is unique among intercom applications.

### Summing Bus

When a group is configured for Summing Bus w/Auto Mix or Summing Bus operating mode audio sources assigned to the group's input channels are mixed (summed or combined). The resulting mix is routed to all the output channels associated with that group. While essentially providing a "unity gain" mixer function, using the Model 5422A's web menu pages allows the level of each input and output channel can be adjusted over a  $\pm 20$  dB range. The summing bus operating mode can be useful for general-purpose audio mixing applications where multiple Dante channels need to be combined. When the Summing Bus w/Auto Mix operating mode is selected it may allow a Model 5422A to be useful in applications well beyond broadcast intercom. This will allow a Model 5422A to be useful in applications well beyond broadcast intercom. This may prove especially useful in audio applications that require combining many voice sources. Press conferences, sports interview configurations, and government meeting situations may all benefit from this capability.

### Pass-Thru

Each group can be independently configured for a unique operating mode called Pass-Thru. This implements an audio function that routes each Dante receiver (input) channel directly to an associated Dante transmitter (output) channel. This simple but sophisticated function will allow any Dante signal to utilize the Model 5422A's capability to support up to 32 Dante flows. This can be useful as a "flow expander" when used in an application that includes Dante-compatible products that utilize Audinate's Ultimo™ integrated circuit. (Many products from Studio Technologies use Ultimo.) While an excellent cost-effective means of implementing Dante, using Ultimo has several limitations. The first is its ability to support only two Dante transmitter (output) and two Dante receiver (input) flows. Routing Dante signals through Model 5422A pass-thru channels can facilitate integration with applications that require additional flows.

Pass-thru can also be used as a simple means of adjusting the level of one or more Dante signals. Using the Model 5422A's web menu pages, the level of each input and output channel can be independently adjusted over a  $\pm 20$  dB range. With the unit's ability to support AES67 and the Dante Domain Manager (DDM) application, many specialized interfacing tasks can be accomplished.

## **IFB**

The IFB operating mode is specifically included for productions that utilize the Remote Integration (REMI) or At-Home model where production personnel are located physically apart from on-air talent. "Interruptible foldback" (IFB) talent cue signals, each typically created from a program audio source and a voice-only interrupt source, are critical for supporting the needs of on-air personnel. Creating these in a REMI environment can be challenging. However, by utilizing the Model 5422A's IFB capability this can become a simple matter. Each IFB function uses two Dante input channels (program audio and interrupt audio) and provides two Dante output channels (program with interrupt and program-only). Configuration choices allow the presence of interrupt audio to be recognized by voice-detect (VOX) or tone-detect (TOX) algorithms. Each will allow creation of excellent talent cueing "feeds." However, TOX provides a unique operating scenario where an 18 kHz (nominal) tone, combined with interrupt audio, can reliably activate and deactivate an IFB function. In this way, an IFB-active signal provided by way of a proprietary data link isn't required for fully "pro" IFB signals to be created. During interrupt activity the program audio can be attenuated (or fully muted) following a configurable parameter. A Model 5422A can have as few as two independent IFB functions by selecting a 4-channel group. Selecting a 32-channel group can provide 16 independent IFB functions. As such, using a Model 5422A-02 allows the creation of up to 32 independent IFB functions.

## **Audio Switching**

When a group is configured for Audio Switching operation a high-frequency tone controls the routing of an audio input source to one of two outputs. The control tone is connected to a separate Dante input, allowing full isolation between the input audio source and the control tone signal. An audio source is connected to a Dante receiver (input) channel and then routed to a designated Dante transmitter (output) channel when a control signal is not present. This is the "normally active" input-to-output path. When the Audio Switching function's tone-detect (TOX) resource recognizes the presence of a high-frequency control tone the audio input source is muted on the normally active output and routed to the normally inactive output. When the high-frequency control tone is no longer present the switching action is reversed.

The Audio Switching function could be described as logically implementing a "form-C" relay or SPDT switch contact action. (Although the audio signal will only flow from the one input to the two outputs.) The switching action is always performed with no clicks, "pops," or other audio artifacts added; full audio fidelity is preserved. The Audio Switching function can be useful for a wide range of applications. A single channel of audio can be controlled for broadcast applications with the audio source and control tone originating at separate locations. Devices such as the Studio Technologies' Model 348 Intercom Station can generate compatible audio control tones. Multiple Audio Switching functions can be easily configured to allow support for multi-channel applications. For example, a single control tone could be used to control audio signals passing through to a 16-, 24-, or 32-channel loudspeaker playback system.

## **Channel Level Adjustment and Labeling**

The nominal level of each Dante receiver (input) channel and Dante transmitter (output) channel can be individually adjusted. This would apply to the 32 channels associated with the Model 5422A-01 and the 64 channels with the Model 5422A-02. The adjustment range is  $\pm 20$  dB in 1-dB steps. This capability can be useful when using a Model 5422A to interface various pieces of equipment that may have different internal operating levels.

The Model 5422A includes extensive capabilities to allow the labeling (naming) of Dante audio channels. This can help ensure that the specific configuration selected for a Model 5422A can be understood by other technical personnel. In this way, changes to channel labels won't require the use of the Dante Controller application although the labeling conventions are, of course, fully compatible.

## **Flexible Networking Capability**

Using the Dante Controller application program, the Model 5422A's three Gigabit Ethernet ports can be selected to operate in one of four modes: Switched, Redundant, Switched+Mgmt, and Redundant+Mgmt. This should allow virtually any desired networking implementation to be easily achieved.

In the Switched mode a single Ethernet connection to either of the Model 5422A's two Dante Ethernet ports will provide connectivity to the associated Dante network. The remaining Dante Ethernet port will provide Dante network "loop-through" capability and can be used to interface with another piece of Ethernet-connected equipment. The management Ethernet port will be used to access the Model 5422A's monitoring and configuration webpages.

In the Redundant mode two independent Ethernet connections are made to the Model 5422A's two Dante Ethernet ports, enabling Dante's redundant networking capabil-

ity. Again, the management Ethernet port will be used to access the Model 5422A's monitoring and configuration webpages. Using either of these network modes allows separate network connections to be maintained for Dante audio and management purposes.

In the Switched+Mgmt mode a single Ethernet connection is used for both Dante audio functionality as well as providing access to the Model 5422A's management webpages. The remaining Dante Ethernet port will provide network "loop-through" capability and can be used to interface with another piece of Ethernet-connected equipment.

In the Redundant+Mgmt mode two Ethernet connections can be made to the Model 5422A's two Dante Ethernet ports. This will allow independent audio networking capability for redundant Dante applications. Access to the Model 5422A's management webpages will be made by way of the Ethernet connection made to the primary Dante Ethernet port.

### **Operating Power**

The Model 5422A allows an AC mains source of 100-240 V, 50/60 Hz to be directly connected. It can also be powered using a 10-18 volts DC source that is connected via a broadcast-standard 4-pin XLR connector. If both AC and DC power sources are connected to a Model 5422A, the unit will be powered by the AC mains supply. Only if the AC mains source fails will a load be placed on the DC source. This allows a source of DC, typically a battery pack, to serve in a backup capacity. With this arrangement normal operation can continue even if AC mains power is lost.

### **Updating & Future Capabilities**

The Model 5422A was designed so that its capabilities can be enhanced in the future. A USB connector, located on the unit's back panel, allows the Main and FPGA firmware (embedded software) to be updated using a USB flash drive. The Model 5422A uses Audinate's Brooklyn II interface module to implement Dante. The firmware in this module can easily be updated using the Dante Updater application that is included with the Dante Controller application. All software files and configuration parameters are stored in non-volatile memory.

## **Installation**

In this section the Model 5422A will be mounted in one space (1U) of an equipment rack. Up to three Ethernet data connections will be made using standard RJ45 patch cables. AC mains and/or DC power will be connected to the Model 5422A. AC mains power can be connected by means of a detachable cord that is compatible with the unit's 3-pin IEC 320 C14 inlet connector. Some applications may warrant connection to a source of nominal 12 volts DC

which can be made by way of a 4-pin XLR connector. A DC source can be used to power the Model 5422A as well as serving as a backup power source should AC mains not be present.

### **What's Included**

The shipping carton contains a Model 5422A Dante Leader Clock and instructions on how to obtain an electronic copy of this guide. Also included in the shipping carton is a North-American-standard AC mains cord. For destinations outside of North America the local reseller or distributor should provide an appropriate AC mains cord.

### **Mounting the Model 5422A**

The Model 5422A Dante Leader Clock requires one space (1U) in a standard 19-inch (48.3 cm) equipment rack. Secure the unit into the designated equipment rack using two mounting screws per side. As the Model 5422A does not contain a fan or other noise-producing source it can be located within a room or other structure where audio monitoring is going to take place.

Twisted-pair (UTC) Ethernet has a 100-meter (325-foot) interconnection cable limitation. But that can be overcome by using fiber-optic interconnections between the Model 5422A and the Ethernet switch or switches in the one or more associated local-area-networks (LANs).

### **Ethernet Connections**

The Model 5422A provides three Gigabit Ethernet (GigE) ports for flexibility and compatibility with many networking implementations. Two ports are provided for interconnections with one or two local area networks (LANs) associated with Dante audio-over-IP networking schemes. They are labeled as PRI (primary) and SEC (secondary). The third Ethernet port, labeled MGMT, can be used to access the Model 5422A management resources. An internal web server function supports the Model 5422A's management port's webpages. These webpages are used for configuration, monitoring, and maintenance of Model 5422A operation. Refer to Figure 2 for an overview of the Model 5422A's three Ethernet ports and how they can operate.

Using the Dante Controller application, the three Ethernet ports can be configured to operate in one of four modes: Switched, Redundant, Switched+Mgmt, or Redundant+Mgmt. If configured for either the Switched or Redundant modes the management webpages are accessed by way of the management Ethernet port. When configured for the Switched+Mgmt mode the management webpages are accessed by way of either the primary or secondary Ethernet port. When configured for the Redundant+Mgmt mode the management webpages are accessed using an Ethernet connection made to the primary Ethernet port.



Dante Controller Network Switch Configuration	Model 5422A Ethernet Port		
	Pri	Sec	Mgmt
Switched	Dante		Management
Redundant	Dante Primary	Dante Secondary	Management
Switched+Mgmt	Dante and Management		Disabled
Redundant+Mgmt	Dante Primary and Management	Dante Secondary	Disabled

**Figure 2. Model 5422A Ethernet Port Configuration and Operation**

By providing three Ethernet ports and four configuration modes, the Model 5422A allows support for virtually all facilities, including those that utilize separate networks for Dante audio transport and equipment management. In this way, “production” networks that support transport of audio signals by way of a single LAN (Switched mode) or two LANs (Redundant mode) can be separate from an engineering network that is used by technical personnel for configuring and maintaining a facility or “plant.”

Connections to the three Ethernet interfaces are made by way of standard RJ45 jacks that are located on the back of the Model 5422A’s enclosure. The Ethernet interfaces support auto MDI/MDI-X so that crossover cables are not required. Refer to Appendix A, located at the end of this guide, for examples of how the Model 5422A’s three Ethernet interfaces might be utilized. This topic is also covered in detail in the Dante Configuration section of this guide. It’s difficult to conceive of a network environment that the unit wouldn’t be able to effectively support.

### Dante Port Connections

At least one 1000BASE-T (GigE) Ethernet connection is required for Model 5422A Dante operation. It should be connected to the primary RJ45 jack. A second 1000BASE-T (GigE) connection can be made to the secondary RJ45 jack if Redundant Dante is desired. For this functionality to be active the Model 5422A’s network configuration must be set for the Redundant or Redundant+Mgmt mode within the Dante Controller software application. While technically 100BASE-TX (100 Mb/s) Ethernet can also be used for these Dante connections, it is not optimal. Additionally, it’s important to note that 10BASE-T (10 Mb/s) Ethernet connections are not sufficient.

When configured in Dante Controller for the Switched or Switched+Mgmt modes the Model 5422A’s Dante secondary Ethernet connection can also be used as a “loop through” port such as would be provided by an Ethernet switch. Using the Dante secondary port in this manner for applications other than troubleshooting or “looping” to access the Model 5422A’s management port is not recommended. It will function reliably but “daisy chaining”

Ethernet signals can limit flexibility and present a failure point; it’s optimal if each Dante Ethernet interface connects directly to a separate port on an Ethernet switch.

### Management Port Connection

If required by the needs of an application, the management webpages can be accessed using an Ethernet signal connected to the Model 5422A’s management Ethernet port. This requires that the network mode in Dante Controller be configured for Switched or Redundant. It’s recommended that a 1000BASE-T (GigE) connection be made but a 100BASE-TX (100 Mb/s) connection is sufficient. (GigE will provide the best performance and it’s assumed that all contemporary applications will support it.)

Access to the Model 5422A’s management webpages can also be obtained using the same network connection or connections that are being used for Dante audio. This requires that the network mode in Dante Controller be configured for Switched+Mgmt or Redundant+Mgmt. Appendix A provides example of how these network scenarios can easily be implemented.

### Connecting Power

The Model 5422A requires a source of AC mains or nominal 12 volts DC for operation. Either source can be connected with the same result. Both can also be simultaneously connected if a redundant (backup) power scheme is desired.

### Connecting AC Mains Power

The Model 5422A can operate directly from AC mains power of 100 to 240 volts, 50/60 Hz, 5 watts maximum. As a “universal mains input” device there are no switches to set or jumpers to install. A 3-pin IEC 320 C14 inlet connector on the back panel mates with a detachable mains cord set.

All units are supplied from the factory with an AC mains cord that has a North-American (NEMA 5-15L) standard plug on one end and an IEC 320 C13 connector on the other end. Units intended for use in other destinations require that an appropriate mains cord be obtained. The wire colors in the mains cord should conform to the internationally recognized color code and be terminated accordingly:

Connection	Wire Color
Neutral (N)	Light Blue
Line (L)	Brown
Earth/Ground (E)	Green/Yellow

Because the Model 5422A does not contain a power on/off switch it will begin operation as soon as AC mains power is connected.

**Safety Warning:** The Model 5422A does not contain an AC mains disconnect switch. As such, the AC mains cord plug serves as the disconnection device. Safety considerations require that the plug and associated inlet be easily accessible to allow rapid disconnection of AC mains power should it prove necessary.

### Connecting DC Power

The Model 5422A can also operate from a source of 10 to 18 volts DC. The current required from a 12 volts DC source is 0.5 ampere (500 milliamperes) maximum. A 4-pin male XLR connector, located on the unit's back panel, is used to connect the source of DC. Prepare a mating connector (female) so that pin 1 is DC– and pin 4 is DC+. Pins 2 and 3 are not used and should remain unconnected. This connector type and pinout have become a broadcast DC power standard and should be familiar to many technical personnel. Because the Model 5422A contains no power on/off switch it will begin operation as soon as a DC power source is connected.

As previously mentioned, both an AC mains source and a DC source can be connected at the same time. If this is the implementation then the AC mains source will always power the Model 5422A with the DC source serving as a “hot standby.” Only if the AC source fails will the unit draw power from the DC source. This will occur automatically with no interruption of Model 5422A operation. In this “standby” mode (when an AC mains source is connected) the Model 5422A draws less than 110 microamperes (uA) from a 12 volts DC input.

## Dante Configuration

For audio signals to pass to and from the Model 5422A requires that a number of Dante-related parameters be configured. These configuration settings are stored in non-volatile memory within the Model 5422A's Dante network interface circuitry. Configuration will typically be done with the Dante Controller software application, available for download free of charge at [audinate.com](http://audinate.com). Versions of Dante Controller are available to support several operating systems. Refer to Appendix B for a list of the Model 5422A configuration default values that are associated with Dante Controller.

The Model 5422A's Dante interface is compatible with the Dante Domain Manager (DDM) software application. Refer to DDM documentation, available from Audinate, for details on which Model 5422A parameters may need to be configured.

### Audio Routing

As previously discussed, the Model 5422A is available in two versions. The Model 5422A-01 has 32 Dante audio input and 32 Dante audio output channels. The Model 5422A-02 has 64 Dante audio input and 64 Dante audio output channels. The latter is organized into two 32-channel groups.

Some or all of the Model 5422A-01's 32 Dante receiver (input) channels will be routed (Dante subscribed) to Dante transmitter (output) channels on associated equipment. Some or all of the Model 5422A-01's 32 Dante transmitter (output) channels will be routed to the Dante receiver (input) channels on associated equipment. These routes (Dante subscriptions) will connect signals from related Dante devices to and from the Model 5422A's audio processing resources. Extensive configuration choices allow the Model 5422A's audio channels to be organized into various group sizes. Each group can be configured for how it will function. For example, Dante beltpacks can be routed to inputs and outputs on a Model 5422A-01 group to create one or more “virtual” party-line circuits. Details regarding configuring groups sizes and group functions are covered later in the guide.

As the Model 5422A-02 supports a total of 64 channels (two groups of 32-channels each) the amount of audio channel routing required can be up to twice that of a Model 5422-01. Since there are 64 input and 64 output audio channels up to 128 routes (Dante subscriptions) may need to be established. The reason that all the channels associated with a Model 5422A may not need to be routed is simple. Most applications will be designed to have unused (“spare”) channels that will allow future expansion and resource re-allocation.

Both versions of the Model 5422A use the Brooklyn II module to implement their Dante functionality. The number of transmitter flows associated with this module is 32 and, as such, no flow limitation will typically occur. These flows can either be unicast, multicast, or a combination of the two. Note, however, that when AES67 mode is enabled in Dante Controller the Dante transmitter (output) channels will only function in multicast; unicast is not supported.

### Unit Name and Channel Labels

The Model 5422A has a default Dante device name of **ST-5422A-** along with a unique suffix. The suffix identifies the specific Model 5422A that is being configured. The

suffix's actual alpha and/or numeric characters relate to the MAC address of the unit's Brooklyn II module.

The default labels (names) of the Dante receiver (input) and Dante transmitter (output) audio output channels will depend on the operating mode configuration of the selected groups. For most operating modes it's preferred that the label for a receiver (input) and a transmitter (output) be identical. (In most cases, an input has a corresponding output.) For user or application clarity, these labels can be revised using either the Dante Controller application or by way of Model 5422A configuration webpages. Editing channel labels using Dante Controller requires separate entries for Dante receiver (input) and Dante transmitter (output) channels. This can be effective but tedious, requiring care to ensure that, when appropriate, channel "pairs" are labeled in a similar fashion. Using the "smart" channel labeling capability provided by the Model 5422A's webpage function is highly recommended. This method allows a single entry to select the label for both the receiver (input) and transmitter (output) channels. Refer to the Model 5422A Configuration section of this guide for details regarding "smart" channel labeling.

## Device Configuration

The Model 5422A only supports an audio sample rate 48 kHz with no pull-up/down options available. The digital audio data is in the form of pulse-code modulation (PCM) samples. A bit depth of up to 32 can be supported. Clocking and Device Latency can be adjusted if required but the default values are typically correct. Encoding choices are PCM 16, PCM 24, and PCM 32.

## Network Configuration – Dante

As has been covered previously in the Installation section of this guide, the Model 5422A allows connection of one, two, or three Ethernet signals using standard RJ45 jacks which are located on the unit's back panel. Useful information is also provided in Appendix A, located at the end of this guide, which provides graphic views of how the RJ45 jacks can be utilized.

In many applications, two of the jacks will be used for Dante audio and the third for connecting to a network designated for device management purposes. It's also possible to access the Model 5422A's management webpages using the Dante Ethernet ports. The Model 5422A's Dante ports are labeled PRI and SEC indicating that they are typically used for the primary and secondary connections. The third Ethernet port is labeled MGMT, indicating that it is intended for use accessing the management webpages. The functioning of these three Ethernet ports can be selected in the Network Config – Switch Configuration section of Dante Controller. Choices are: Switched, Redundant, Switched+Mgmt, and Redundant+Mgmt.

If the Switched mode is selected then the Model 5422A can establish one Dante audio connection with an Ethernet network. It doesn't matter which RJ45 jack is utilized, PRI or SEC, although for clarity this would typically be the primary (PRI) jack. The secondary (SEC) RJ45 jack can be used to interconnect with another piece of networked equipment. The management (MGMT) Ethernet port will be used to access the management webpages.

If the Model 5422A's Dante network is configured for the Switched mode ensure that only one of the two Dante RJ45 jacks (PRI or SEC) on the back panel is connected to the LAN associated with the Dante network. If both of the Model 5422A's Dante RJ45 jacks are routed to ports on the same LAN this will typically "crash" the network! (Although some of the latest/most-advanced Ethernet switches will automatically detect and prevent such a "network bridging" issue from occurring.)

If the Switched+Mgmt mode is selected the same issues as discussed in the previous two paragraphs would again apply. The only difference is that the management webpages would be accessed using the same Dante Ethernet port that is being used to access the Dante network. The management (MGMT) Ethernet port will be disabled.

If the Redundant mode is selected then Dante's Redundant networking capability will be enabled. In this case, separate Ethernet LAN connections should be made to the Dante primary (PRI) and Dante secondary (SEC) RJ45 jacks. Again, the Model 5422A's separate management (MGMT) Ethernet port will be used to access the management webpages.

If the Redundant+Mgmt mode is selected in Dante Controller then the network connection made to the Dante primary (PRI) Ethernet port will also be used to access the management webpages. The Model 5422A's separate management (MGMT) port will be disabled.

## IP Addresses

When a Model 5422A has been configured for either the Switched or Switched+Mgmt network mode a single Dante IP address will be associated with the network connection that is made to either the Dante primary (PRI) or the Dante secondary (SEC) RJ45 jack. If the network configuration has been selected for the Redundant or Redundant+Mgmt mode then separate IP addresses and related network parameters will be assigned to the Dante primary (PRI) and Dante secondary (SEC) Ethernet ports. No matter what network mode has been selected the Model 5422A will always have a separate management IP address.

Typically, the Model 5422A's Dante IP address or addresses and related network parameters will be determined automatically using DHCP or, if that's not available, the

link-local network protocol. If desired, the Dante Controller application does allow Dante IP addresses and related network parameters to be manually set to a fixed (static) configuration. While this is a more-involved process than simply letting DHCP or link-local “do their thing,” if fixed addressing is necessary then this capability is available.

Note that if the Model 5422A's network configuration has been set for the Redundant or Redundant+Mgmt mode then the Dante primary and Dante secondary IP addresses and related parameters can be independently configured. This allows both Dante interfaces to be configured automatically, both interfaces to be configured manually, or one interface to be configured automatically and the other to be configured manually.

By default, the Model 5422A's management IP address and related network parameters will be determined automatically using DHCP or link-local. A configuration option, accessible using front-panel menus (by way of the display and associated buttons) or the management webpages, allows manual control of the management IP address, subnet mask, and gateway address values.

### **AES67 Configuration – AES67 Mode**

Dante Controller allows a Model 5422A to be configured for AES67 operation. This requires the AES67 mode to be set for Enabled. As previously noted in this guide, if AES67 mode is enabled then all the Dante transmitter (output) channels will use multicast; unicast will not be supported.

### **Model 5422A Clocking Source**

While technically the Model 5422A can serve as a Leader clock for a Dante network (as can all Dante-enabled devices) in most cases, the unit will be configured to receive its timing reference (“sync”) from another Dante device. As such, the check box for Preferred Leader that is associated with the Model 5422A would typically not be enabled.

## **Model 5422A Configuration**

Many Model 5422A Dante Intercom Audio Engine operating parameters are configured using the management system's webpages that are provided by way of one of the unit's Ethernet ports. The specific port utilized for accessing the management system will depend on the network configuration that is selected using the Dante Controller application. A standard web browser is all that is required to utilize the menu webpages.

The manner in which the Model 5422A handles audio signals is configured using the webpages. Parameters for the network settings and user access are also handled using the management system and associated webpages. In addition, a number of display-only fields show key operating parameters.

Several key network configuration parameters can also be viewed and revised using the Model 5422A's front-panel graphics display and associated pushbutton switches. Refer to Appendix C for details on which parameters can be revised in this manner.

### **Management IP Address**

It's easy to identify the Model 5422A's management IP address by way of the front-panel display. If the screen saver function is active, as it will be in most situations, one of the three pages that will automatically display will show the current management IP address. As such, a user can simply observe the sequencing menu pages and watch for the one that displays the current management IP address. If it's desired that the current management IP address be continuously displayed then the Enter pushbutton switch on the front panel should be pressed. This will stop the screen saver function and cause the current management IP address to display. It will also allow the various menu pages to be accessed using the up, down, left, and right pushbutton switches. Simultaneously pressing the left and right arrow buttons will cause the screen saver mode to begin again. The screen saver mode will also automatically start two minutes after the last press of any of the front-panel pushbutton switches.

How the management Ethernet port obtains its IP address will depend on a management interface configuration setting. The default method is automatic so the Model 5422A's management port will first try to obtain an IP address using DHCP. If that is not successful an IP address will be assigned using the link-local protocol. An address of 169.254.x.x will indicate that an IPv4 address was established using link-local. The Model 5422A may also have been configured to use a manual (fixed or static) IP address. The front-panel display and associated pushbuttons, or the Model 5422A's management webpages, can be used to review and/or make changes to the management IP address and related parameters.

### **Accessing the Management Webpages**

To access the Model 5422A's home webpage, type the unit's management IP address into a browser's search bar. (It's possible that some browsers may require including the text **http://** followed by the IP address.) Of course, the computer associated with the browser must be on the same LAN and subnet as the Model 5422A's management port connection.

## Home Menu

Once the Model 5422A menu system has been accessed a webpage will appear that has both a Home and Login tab across the top. A line of greeting text will display along with a link to the Model 5422A section in the Studio Technologies website.

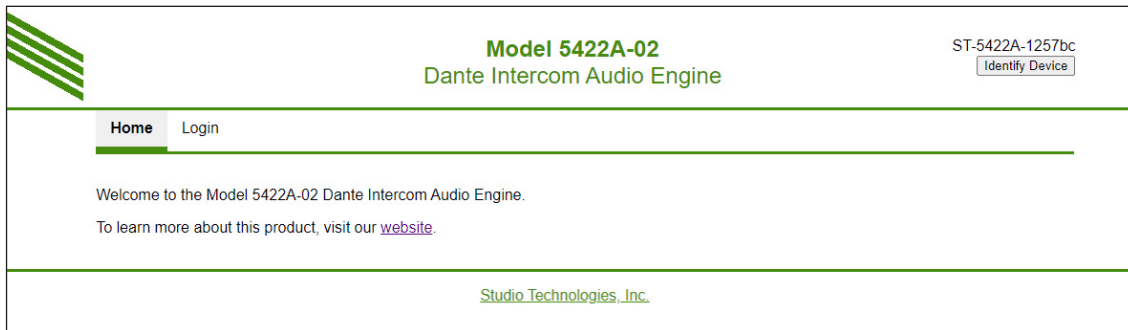

## Login Menu

Click on the Login tab to access the Login webpage. Entry of a valid user name and password is now required to access the configuration and status menus. The Model 5422A doesn't incorporate a sophisticated security implementation. Requiring a user name and password, as well as the underlying software, is intended to keep "honest" people from making unauthorized changes to the configuration of the Model 5422A. It is not intended as a rigorous security system.

Should the applicable user name and/or password be misplaced, refer to the Technical Notes section and/or Appendix E of this guide for a recovery method.

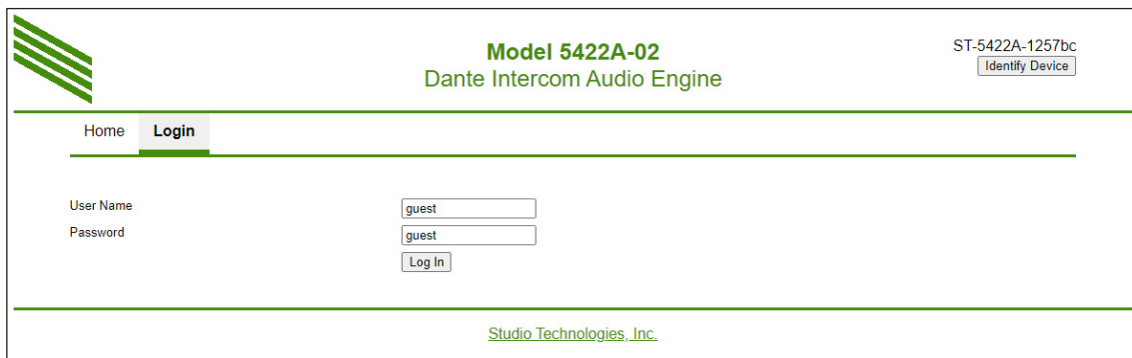

**User Name:** Enter the Model 5422A's user name into this field. It is case sensitive. The default user name is **guest**. If both the default user name and the default password are active then the default user name will display in this field.

**Password:** Enter the Model 5422A's password into this field. It is case sensitive. The default password is **guest**. If both the default user name and the default password are active then the default password will display in this field.

**Log In Button:** Click on the Log In button to submit the entered user name and password. If the correct entries have been made then a Home webpage that includes an expanded set of webpage tabs (choices) will display. If an incorrect user name and/or password is entered then a login failed message will be displayed in text.

## Main Menu

Once the correct user name and password have been submitted an expanded set of menu tabs will be displayed. These choices provide the ability to access additional menu webpages. They allow configuration of audio performance as well as network and access parameters. In addition, information about other important Model 5422A operating parameters can also be reviewed.

As previously discussed, the Model 5422A is offered in two versions. The Model 5422A-01 provides one 32-channel group of audio channels. This is considered a 32-channel audio engine. The Model 5422A-02 provides two 32-channel groups of audio channels. This is considered to be two 32-channel audio engines that support a total of 64 channels. The menu systems for the two versions are quite similar. The only difference is that the Model 5422A-01 has a menu tab called Audio Engine while the Model 5422A-02 has one tab called Audio Engine 1 and another tab called Audio Engine 2.

## Engine Configuration

The Model 5422A-01 has one audio engine consisting of 32 channels. The Model 5422A-02 has two audio engines, each consisting of 32 channels for a total of 64 channels. Two webpages are provided for configuring these audio engines. They are named Group Configuration and Channel Configuration.

### Group Configuration

The channels in each audio engine can be electronically divided into what are referred to as groups. Selecting how the 32 audio engine channels are arranged into groups is crucial when working to achieve the desired Model 5422A configuration. Each group will have a text label that can assist personnel in knowing the purpose of each group. The operating mode of each group can be individually selected. This allows the specific action of each group to be determined.

### Channels per Group

The 32 channels associated with an audio engine can be configured into one of ten configurations which determine the number of groups and how many channels are contained in each group. Choices are:

- 32
- 24, 8
- 20, 8, 4
- 16, 16
- 16, 12, 4
- 12, 12, 4, 4
- 8, 8, 8, 8
- 8, 8, 8, 4, 4
- 8, 8, 4, 4, 4, 4
- 4, 4, 4, 4, 4, 4, 4

As has been previously discussed, each Model 5422A audio engine consists of 32 Dante receiver (input) and 32 Dante transmitter (output) channels. These channel “pairs” can be configured to function in one of the ten available group arrangements. As should be evident, adding together the size of each group will always equal 32. Each group will have a unique label and can be independently configured as to how it will function. How to establish group labels and operating modes will be reviewed later in this guide.

When contemplating changing the Channels per Group configuration it’s important to note two things. The first is that some or all of the Dante channel labels of each group member may automatically change to reflect the revised audio engine configuration. The second issue that could arise is that some or all of the existing Dante audio channel routes (Dante subscriptions) associated with group members will probably be deleted upon a change to the number of Channels per Group configuration. This is simply the result of Dante technology using the channel labels for identifying and establishing routes (Dante subscriptions). A route (Dante subscription) would no longer be valid if an associated channel label has been changed.

The fact that Dante transmitter (output) channel labels may automatically change when the Channel per Group configuration changes is not necessarily a bad thing. But some editing of the channel labels may be required to achieve the desired implementation. Deleting routes (Dante subscriptions) to and from group-member channels will definitely add some extra effort. Routes (Dante subscriptions) will have to be re-established once a new Channels per Group configuration has been selected and confirmed. Again, this is not a terrible thing to have occur. But it’s possible that up to 64 routes (Dante subscriptions), consisting of 32 receiver/transmitter pairs, may have to be re-established.

In conclusion, a change of Channels per Group organization may be destructive as far as channel labels and routes (Dante subscriptions) are concerned. Any changes made to a Channels per Group configuration is “one way” with no method to automatically return to a previous configuration. A change will require that time and effort be spent confirming and possibly revising channel labels and routes (Dante subscriptions).

The identification letter used in group 1 of the audio engine associated with a Model 5422A-01, or group 1 in the first audio engine of a Model 5422A-02, will always start with the letter A. The next group will take on the next alphabetical letter. If an audio engine is configured for four groups (such as 12, 12, 4, 4) then the group identification letters will be A, B, C, and D. If an audio engine is selected for eight groups (4, 4, 4, 4, 4, 4, 4, 4) then the letters in the identification range will be A through H.

The group identification letter for the second audio engine of a Model 5422A-02 will start with J and go, if required, to the letter R. For clarity, the letters I and O will not be used for groups. (They can be confused with the numbers one and zero.)

Within the Model 5422A’s logic circuitry the audio data associated with each group is fully isolated, ensuring that there will never be audio crosstalk between groups. (This is to be expected since all Model 5422A Dante receiver (input) channels, Dante transmitter (output) channels, and processing is performed within the digital domain.)

### **Group Label**

Associated with each group is a label (name) consisting of up to 14 alphabetic or numeric characters. The default label for each group is somewhat generic but can be revised to be more descriptive. There’s no reason why a human-readable label can’t be used to make the function served by each group much clearer. Using labels such as MainPL, ProductionComs, or Maintenance can be effectively utilized. Assigning logical, understandable labels can make long-term application maintenance much easier to perform. The Submit button must be pressed or entered for a revised label to be saved.

### **Operating Mode**

Each group can be independently configured to operate from among seven available operating modes. Choices are: Party-Line w/Auto Mix, Party-Line, Summing Bus w/Auto Mix, Summing Bus, Pass-Thru, IFB, Audio Switching

A detailed explanation of each operating mode will be provided in the following paragraphs. For a revised operating mode to be activated requires the Submit button, located to the right of the selection field, be pressed or enabled.

**Party-Line w/Auto Mix:** This operating mode allows party-line (PL) channels or circuits to be created from Dante signals.

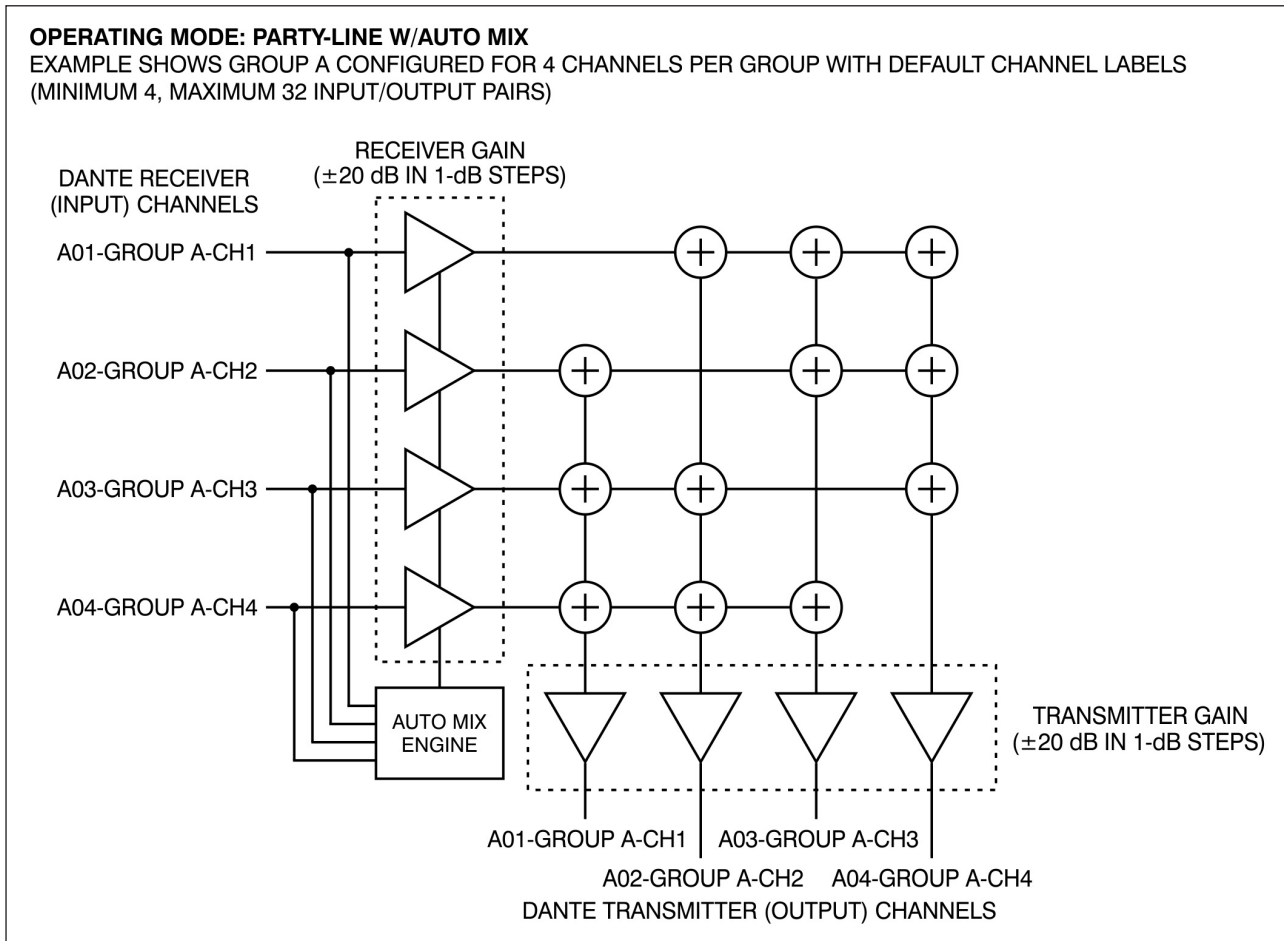

To maximum signal intelligibility, the contribution of each user's talk signal is automatically adjusted using the Auto Mix function. Unlike analog PL, Dante signals designated for intercom use can't simply be interconnected ("banged together") to form common talk/listen channels. PL functionality has to be created within digital logic to form "virtual" PL circuits. To the user the result is essentially the same; all members of a Dante PL can talk and listen at the same time. But how that functionality is created is quite different. As one would expect, all Dante receiver (input) and transmitter (output) channels are independent. In the broadcast or telephony-world these signals would be considered a "4-wire" with separate audio paths for send and receive. As such, they need to be connected to a specialized mixer or combiner resource to allow a virtual PL function to be created. Two signal routes (Dante subscriptions) need to be established for each PL user channel. This channel "pair" must have one signal associated with an intercom device's Dante transmitter (output) channel and a second associated with the intercom device's Dante receiver (input) channel.

The Auto Mix action that applies to this operating mode uses a special audio processing algorithm that provides enhanced audio performance for party-line (PL) applications. This algorithm, implemented in high-speed logic within the Model 5422A's FPGA integrated circuit, automatically adjusts the contribution that each audio input signal makes to the party-line group. This automatic mixing action balances the relative audio level of each input that is contributing a significant signal to the party-line function. It will also significantly reduce the contribution to the overall mix of each audio input signal if its level is determined to be below a fixed threshold. This helps ensure that users who are actively talking on a PL circuit will be clearly heard, while those who are not actively talking will have their background audio minimized.

Technically, within the Model 5422A's logic circuitry multiple line-level mix-minus audio paths (buses) are created from the Dante receiver (input) audio signals; each device that is part of a PL channel or circuit requires an independent mix-minus signal. The concept is simple, each user that's



part of a specific PL wants to hear an audio signal created by a Party-Line w/Auto Mix operating mode function that contains everyone but themselves. They don't want to hear themselves coming back from the Model 5422A as there could be too much or too little level, slight audio time delays, or other audio artifacts. They'll want to hear themselves (by way of their own microphone) but through the sidetone function that is provided by their own beltpack or intercom station.

To further explain, let's use the example of four users that are part of a 4-channel virtual PL circuit created by the Model 5422A. User one wants to hear talk audio from users two, three, and four. User two wants to hear talk audio from users one, three, and four. User three wants to hear talk audio from users one, two, and four. And user four wants to hear talk audio from users one, two, and three. To support these four users requires that the Model 5422A create four unique mix-minus functions. This is accomplished within the unit's digital logic circuitry. Four associated Auto Mix functions help to ensure that the audio that each user receives is uniformly excellent. And finally, for each user to hear themselves (audio associated with their own microphone) each intercom device (typically a beltpack or intercom station) will have an integrated sidetone function.

To summarize, each member of a PL group is assigned its own mix-minus channel, meaning that the audio that it supplies to the group is routed to all other members of the group but not to itself. A user receives confirmation audio from their own microphone by way of its local sidetone function and not from the group's mixing and distribution functions that create the multiple mix-minus buses.

The number of channels in a group that is assigned to the Party-Line w/Auto Mix operating mode defines the maximum number of Dante device talk/listen channels that can join together to form a virtual party-line (PL). The configuration choices range from one 32-channel PL (32), to selecting eight 4-channel groups (4, 4, 4, 4, 4, 4, 4, 4). What configuration choice is optimal for an application will depend on the maximum number of independent PL "circuits" that need to be established. A simple review of an application should lead to the desired group configuration.

While the maximum number of talk/listen channels that can be assigned to a group is defined by the group size, this does not mean that all channels associated with a group have to be utilized. For example, if a Model 5422A is configured to provide four groups of eight channels each, the first and second groups could have five talk/listen channels routed to them while the third and fourth groups could have just three talk/listen channels routed to them. The unused channels in a group don't contribute any noise or audio

artifacts. They are simply "spare" and available for future use, allowing additional talk/listen channels to be routed to them as needed. Groups are just resources that allow talk/listen channels on compatible devices to be linked together. A group size just defines the maximum number of device channels that can be part of a set of users that can talk and listen among themselves.

As an example, if one group of 32 channels is selected (32) then a maximum number of 32 of talk/listen channels from Dante-compatible devices can be routed (Dante subscribed) to the group. This would equate to up to 32 of the Studio Technologies' Model 372A or Model 373A single-channel beltpacks being able to function together in what for the users would be a party-line (PL) or shared communication channel or circuit. If, as another example, an application required that sixteen of the 2-channel Model 370A or Model 371A beltpacks needed to work together to support two independent party-line channels, then a Model 5422A channel configuration choice of two 16-channel groups (16, 16) would be appropriate.

When deploying a PL circuit, it's important to note that two channels are associated with each intercom channel of a Model 5422A group. The Dante transmitter (output) channel of an intercom device will be routed (Dante subscribed) to a Dante receiver (input) channel on a group that has been configured for Party-Line w/Audio Mix operation. The specific Dante transmitter (output) channel associated with that group must be routed to the listen input on that specific intercom device. So, for example, if Dante transmitter (output) channel one of a Studio Technologies' Model 371A Dante Beltpack is routed to input 02 of a Model 5422A PL group, then that group's output 02 must be routed to the receiver (input) of channel one of the Model 370A. Output 02 is the mix-minus signal that channel one of this specific Model 371A requires for correct operation; no other device should utilize output 02.

Restated for clarity, for correct PL operation to take place one, and only one, pair of channels (one "talk" and one "listen") from an intercom user device must be routed (Dante subscribed) to one pair of channels (one "listen" and one "talk") on a Model 5422A PL group. These routes must be made to associated channel pairs on both the Dante beltpack or intercom station devices and Model 5422A PL channels.

Party-line (PL) channel routing (Dante subscribing) is the main area of confusion when users first encounter a Model 5422A. But after some study and experimentation the process should become clear. It's important to remember that when associating an intercom device to a PL channel on a Model 5422A PL group always involves routing (Dante subscribing) two channels. Two routes (Dante

subscriptions) will always be made to add an intercom channel to a Model 5422A PL group. A Dante transmitter (output) channel that has “talk” audio from the intercom device needs to be routed to the input on a PL group. The associated Dante transmitter (output) channel on the same PL group (the specific mix-minus output) needs to be routed to the input on the intercom device. Without routing both channels, PL functionality will not be achieved.

Another suggestion is that unless one is experienced with how the Model 5422A creates PL, start by creating a small implementation. Don't try to route (Dante subscribe) a large number of channels or user devices at one time. The complexity will make it very difficult to achieve the desired result. Begin by creating the world's smallest PL intercom. Link one channel between two user devices. Try the sidetone function on the two user devices. Turn off sidetone and ensure that each user device is getting a “mix-minus” — each should hear the other but not itself. Then set sidetone to the device level. Get that functioning correctly and you'll understand the basics. Only then move on to adding additional user devices. Spending one or two hours experimenting with these topics will help to fully understanding what's going on. From there you'll be ready to implement whatever your final application requires.

**Party-Line:** This operating mode is identical to the Party-Line w/Auto Mix operating mode with the exception that the Auto Mix function is not active. Studio Technologies recommends that in most cases the Auto Mix function be active. But for special applications or test purpose this mode might be appropriate. Refer to the previous section of this guide for details on party-line operation.

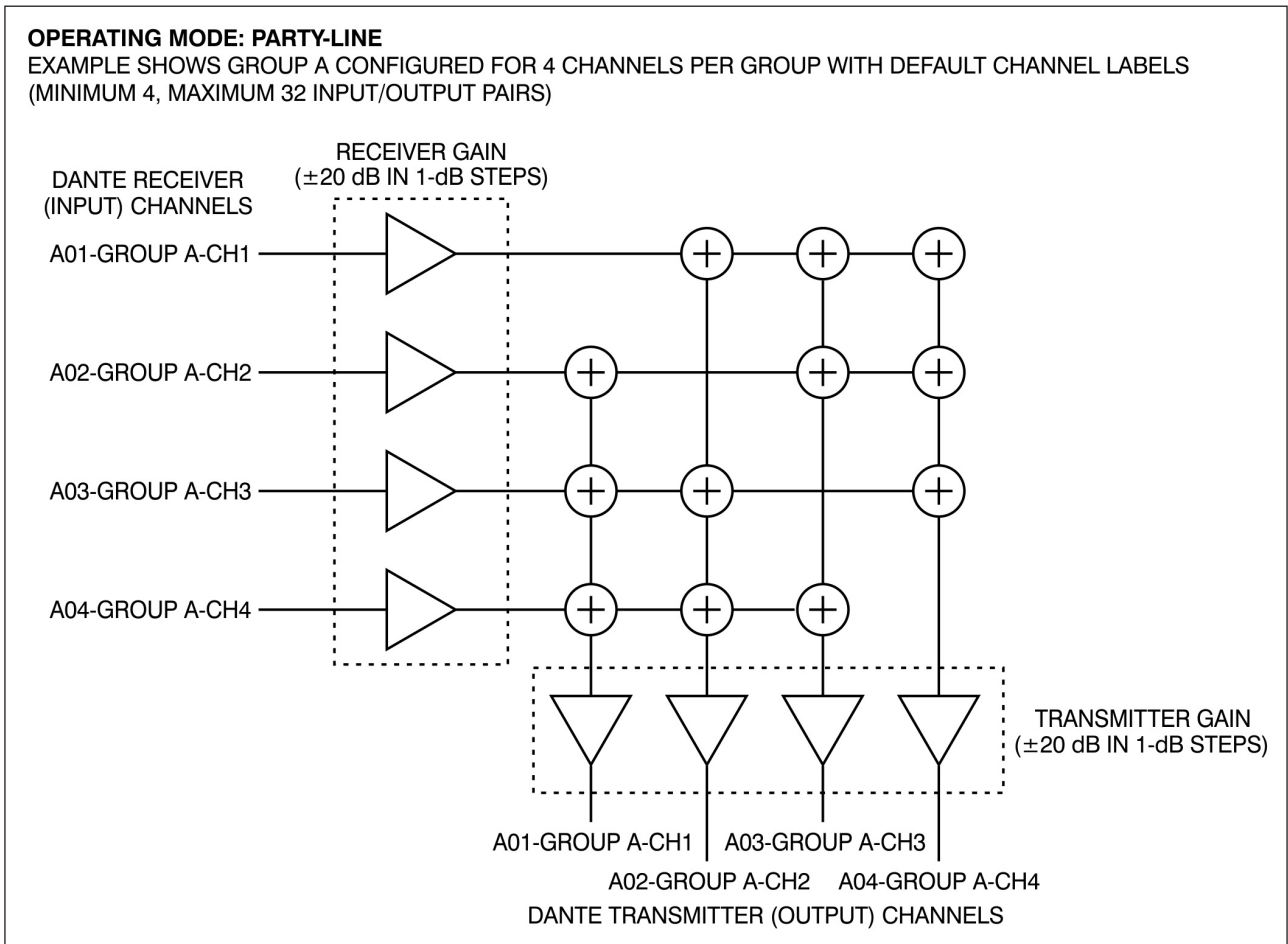

**Summing Bus w/Auto Mix:** This operating mode allows two or more Dante receiver (input) audio signals to be summed (combined, mixed, or added). This mode can be considered as implementing a “unity” gain mixing amplifier or “mix bus” function. However, some flexibility is available. The level of each input can be adjusted over a range of  $\pm 20$  dB as configured using the receiver (input) channel configuration functions. The resulting output of signal mix is provided on multiple Dante transmitter (output) channels. To maximize signal intelligibility, the contribution of each input signal is automatically adjusted using the Auto Mix function. This function is implemented within the Model 5422A programmable logic and was discussed previously in this guide.

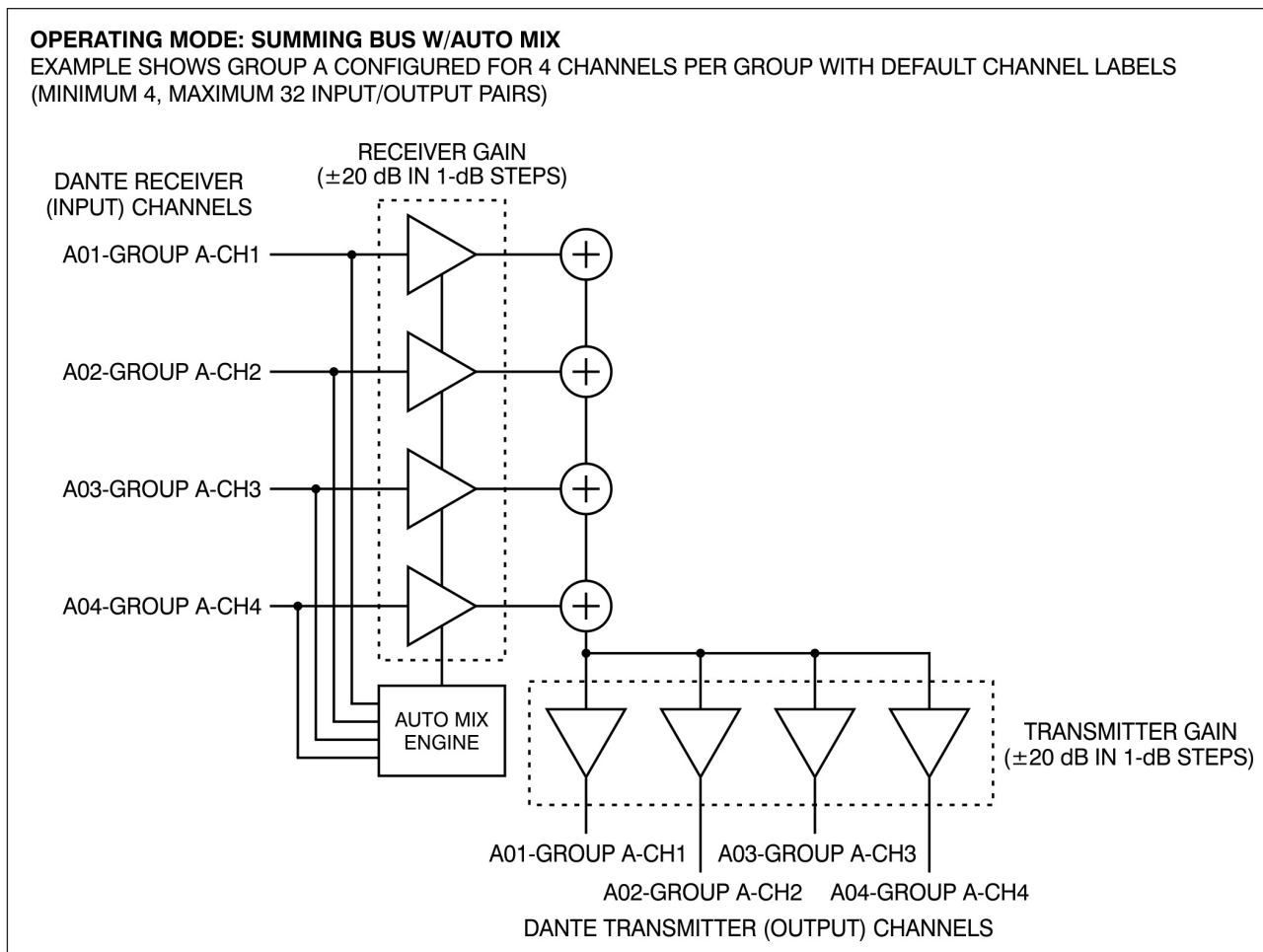

One Summing Bus w/Auto Mix section can be configured as active for each Model 5422A group. As such, the number of input and output channels depends on the selected group size. A group size of 4 would provide four Dante receiver (input) channels. These channels would be combined and output by way of four Dante transmitter (output) channels. A group size of 32 would provide 32 Dante receiver (input) channels whose signals would combine and be output on 32 Dante transmitter (output) channels.

While the output of the summing bus is made available on multiple Dante transmitter (output) channels, flexibility in nominal level is provided. The content of the signals available on each of the Dante transmitter (output) channels of

a group is the same. But the level of each output can be adjusted over a  $\pm 20$  dB range using the transmitter (output) configuration function.

Any one of the outputs can be routed (Dante subscribed) to multiple Dante receivers (inputs) on associated equipment. Or a function’s multiple outputs can be routed (Dante subscribed) to the one or more Dante receivers (inputs) on multiple products. Installer preference and the required nominal level will dictate how the Dante transmitter (output) channels will be utilized. The overall connection limitation is really the number of supported Dante flows, which in the case of the Model 5422A is 32. (In most cases, a Dante flow will consist of a connection that supports up to four audio channels.)

The Summing Bus w/Auto Mix operating mode can be useful for a variety of on-air, IFB-related (talent cueing), production, and general-audio applications. With the inclusion of Auto Mix functionality this operating mode can make the Model 5422A an important part of an application that needs a means of combining multiple audio sources with automatic control over the signal “mix.” To achieve this has, in the past, typically required the use of a stand-alone audio processor, portable analog-supporting mixer unit, or digital plug-in.

**Summing Bus:** This operating mode allows Dante receiver (input) audio signals to be summed (combined, mixed, or added). This mode can be considered as implementing a “unity” gain mixing amplifier or “mix bus” function. The resulting output signal is provided on multiple Dante transmitter (output) channels. For flexibility the input and output levels can be adjusted over a  $\pm 20$  dB range using the receiver (input) and transmitter (output) functions.

This mode is identical to the Summing Bus w/Auto Mix operating mode with the exception that the Auto Mix function is not active.

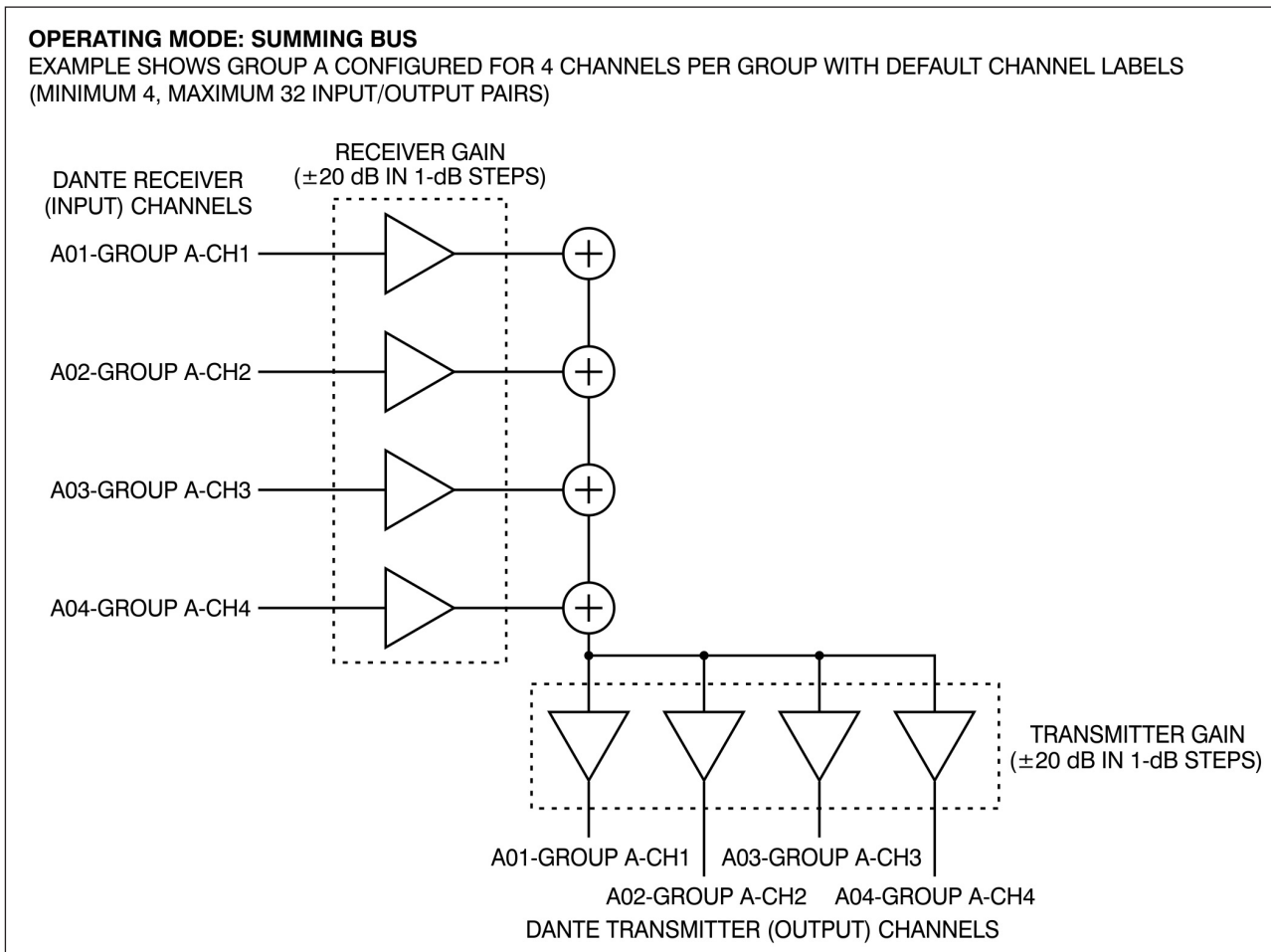

**Pass-Thru:** This operating mode allows one Dante receiver (input) audio signal to be routed directly to another Dante transmitter (output) channel. The same audio data that arrives on the input channel is sent to the output channel; nothing is added or removed. The Pass-Thru operating mode is primarily provided as a Dante flow “expander.” (A Dante flow is typically a group of up to four audio channels that are connected from one Dante-compatible device to another. All Dante devices support a fixed number of flows, some as low as four while others have 64 or even more.) The Pass-Thru operating mode can also be useful for interfacing Dante transmitter (output) channels that are not compatible with the Dante Domain Manager (DDM) application with Dante receiver (input) channels that do require DDM compatibility. (All Model 5422A Dante connections are DDM compatible.) Finally, Pass-Thru channels allow adjustment of a signal’s nominal level. (Each Dante receiver (input) and transmitter (output) channel allows a gain adjustment of  $\pm 20$  dB.)

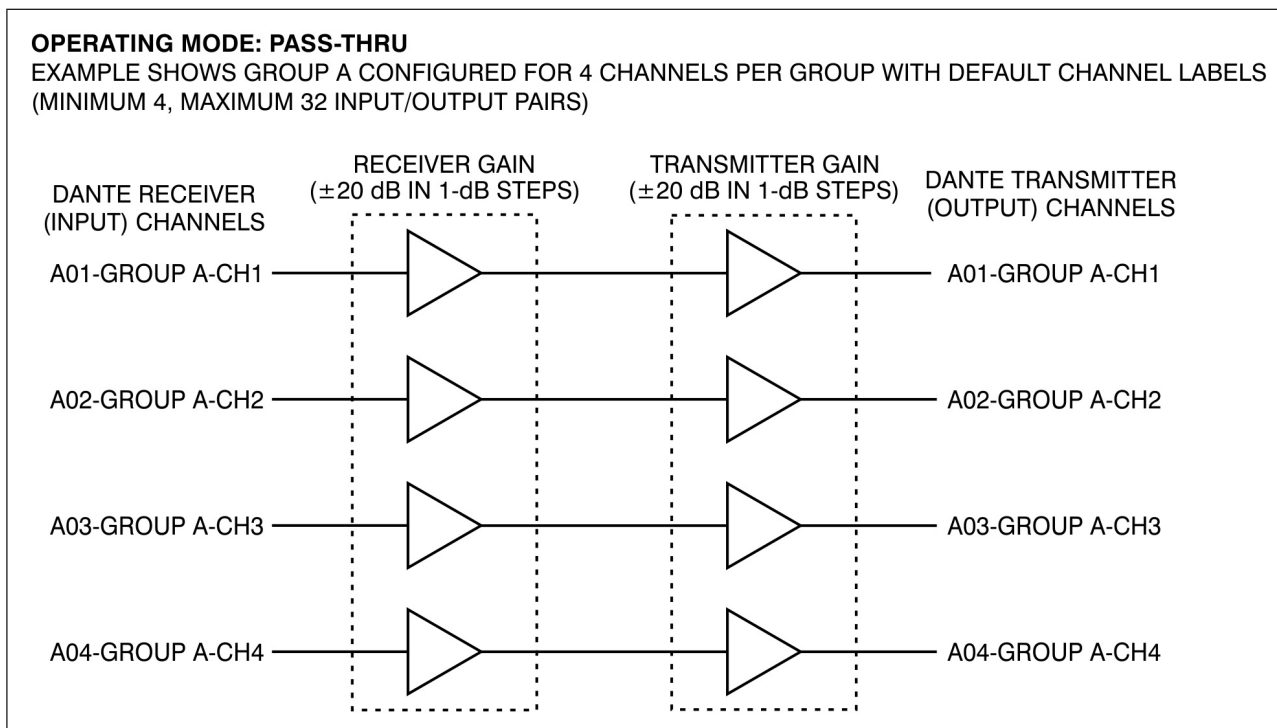

Dante interfaces, such as ones that utilize the popular 2-in/2-out or 4-in/4-out Ultimo™ integrated circuit, are limited to just four flows, two in each direction. This will restrict the number of destinations that a Dante transmitter (output) channel associated with an Ultimo-based interface that can be routed (Dante subscribed) to a maximum of two. The Model 5422A uses the Brooklyn II module to implement its Dante interface. This module supports a maximum of 64 Dante flows, 32 in each direction. As such, using the Model 5422A’s Pass-Thru operating mode would allow flow-limited devices to take advantage of the Model 5422A’s larger flow resources. In the broadcast world the Pass-Thru operating mode can be considered to be a special Dante flow “distribution amplifier” function.

A practical application would be to allow the Dante transmitter (output) channels provided by Studio Technologies’ products that utilize the Ultimo integrated circuit to interconnect with more than two devices. For example, the popular Model 204/205/206-series of announcer’s console units utilize Ultimo to implement their Dante interfaces. As such,

Dante transmitter (output) channels associated with these announcer’s consoles can only be routed (Dante subscribed) to two unique destinations. This can be a problem for some applications, especially with the 4-channel Model 206. However, a solution to this limitation is quite simple to achieve. By first routing (Dante subscribing) these Dante transmitter (output) channels through sections associated with the Pass-Thru operating mode the number of flows is now limited to that provided by the Model 5422A. The flow limitation of two has been “expanded” to 32! The audio signal from the announcer’s console can now be routed (Dante subscribed) to as many destinations as is practically required.

Each Pass-Thru section uses one Dante receiver (input) channel and one Dante transmitter (output) channel. The number of Pass-Thru sections provided by a Model 5422A group depends on the selected group size. A group size of 4 would provide four independent Pass-Thru sections. A group size of 32 would provide 32 independent Pass-Thru sections.

**IFB:** This operating mode is provided so that a broadcast-type talent cue (IFB or interrupted foldback) signal can be created from two Dante audio sources. The Model 5422A implements IFB such that both program with interrupt and program only channels are created. All IFB action is controlled using audio signals within the Dante receiver (input) audio channel specified for interrupt. This “in-band” audio can be either voice-only or voice-with-high-frequency audio. With the latter method a high-frequency tone (typically an 18 or 20 kHz sine-wave signal) is used to trigger or “key” the IFB function. No external IFB active data or hardware signal is required.

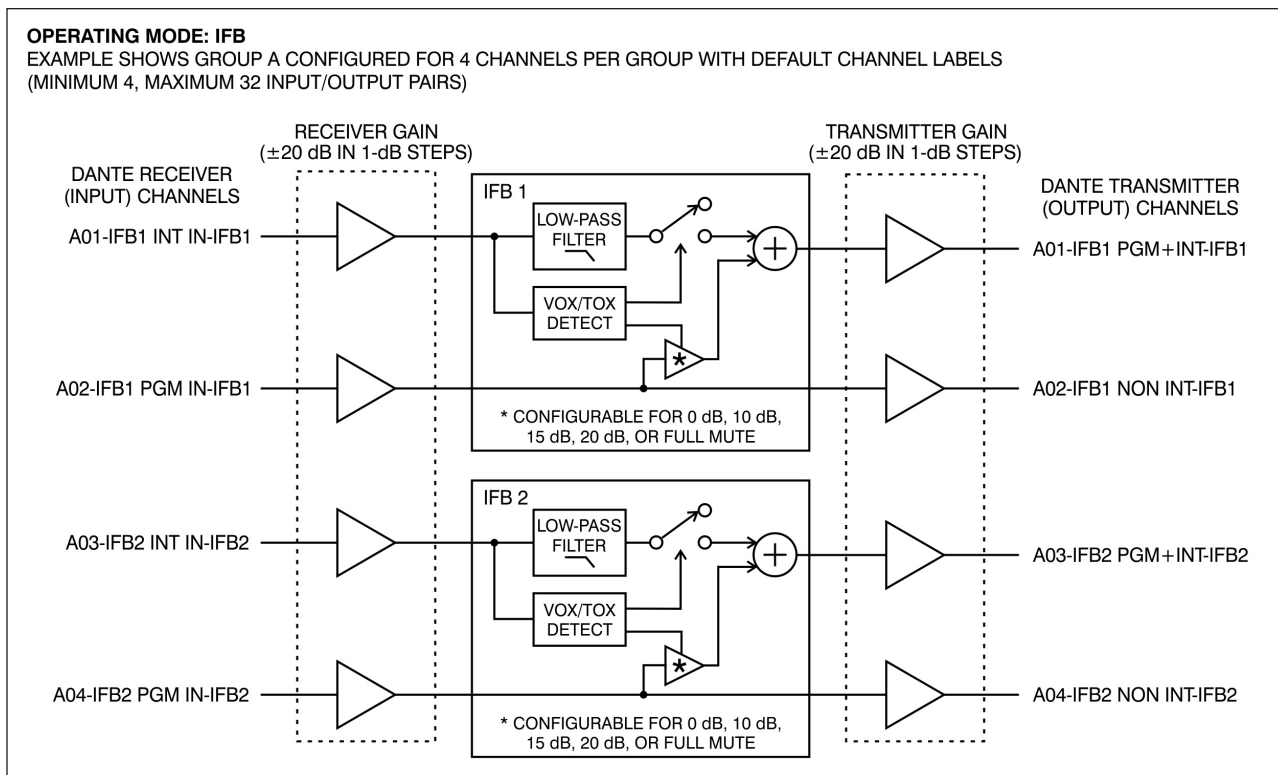

The Model 5422A’s IFB functionality was specifically implemented so that professional-grade IFB signals could be created entirely within the Dante domain. This allows support for both local and REMI/At-Home applications without the need for matrix intercom systems or extensive hardware. Compatibility is provided with many other products from Studio Technologies, including the Model 348 Intercom Station, Model 354 Talk Station, and various announcer’s console models.

Each IFB section uses two Dante receiver (input) channels and two Dante transmitter (output) channels. One Dante receiver (input) channel is designated for use by the interrupt audio source while the other receiver channel is designed as the program audio source. One Dante transmitter (output) channel is designed as the program with interrupt (“interrupt”) channel and the other as the non-interrupt (“program” or “program only”) channel. The number of IFB sections provided by a Model 5422A group depends on the selected group size. A group size of 4 would provide two independent IFB sections. A group size of 32 would provide 16 independent IFB sections.

The audio signal connected to the Dante receiver (input) channel that is designated for interrupt is used for two purposes. The first purpose is that it is monitored to determine if it is active. An active interrupt input can be configured to be detected as either the presence of audio within the voice band (VOX) or the presence of high-frequency content (TOX). When the interrupt input is detected as on (active) the interrupt audio source is automatically routed to the program with interrupt output channel. If TOX is selected as the interrupt detection method the interrupt audio is sent through a low-pass-filter function before it is routed to the program with interrupt output. (This removes the high-frequency interrupt “trigger” content, preventing it from being sent to a user.) Whenever the interrupt input is not detected as being on (detected as off) the interrupt audio source is not routed to any output channel.

The program audio input source that is routed (Dante subscribed) to the designated Dante receiver (input) channel is always routed to the Dante transmitter (output) program audio channel. This signal doesn’t change and provides the IFB function’s non-interrupt (“program” or “program



only”) audio channel. When the interrupt audio source is not detected as being active (interrupt off state) the program audio input signal is also routed, at full level, to the Dante transmitter (output) program with interrupt channel. When the interrupt audio source is detected as being active (on) the level of the program audio source as it is routed to the program with interrupt channel will be impacted by the configured IFB Dim value. This can range from 0 dB (no level change) to a full mute (fully attenuated). Between those extremes dim (attenuation) values of 10, 15, and 20 dB are available.

In most broadcast applications, when IFB is active it is desirable for the program audio level to reduce in level but not fully mute. In these situations, 15 dB is typically an effective value. However, there are other situations where selection of 0 dB or Full Mute would be appropriate. For audio-with-picture Foley (sound effects) work selecting 0 dB (no attenuation) would typically be desired. This would allow audio cues (from a producer or director) to be communicated with the Foley artist without impacting the program audio level. In the case of on-air news applications, IFB signals utilized in environments where ambient levels can be high the full mute setting can be appropriate. This would allow interrupt audio to really “cut through” to talent, minimizing the chance of confusion from program audio content. In this case, the interrupt audio activity is typically short in duration and important to accurately reach the on-air personnel. In all cases the changing of program level will be “click free,” changing levels without audio artifacts. The same would apply to the on/off state of the interrupt audio signals.

Associated with the IFB operating mode are two parameters that can be configured. One is IFB Detection Mode and the other is IFB Dim Level. Details about both are provided in the following sections.

#### ***IFB Detection***

Choices are: Voice-Operated (VOX), Tone-Operated (TOX)

This choice selects whether interrupt activity will be detected using the voice-operated (VOX) function or the tone-operated (TOX) function, both of which are implemented within the Model 5422A’s logic circuitry. For a detailed description of the VOX and TOX functions refer to the Specifications section of this guide. This setting applies to all IFB sections that are established within a specific audio engine. (In the Model 5422A-02 there would be two settings for the IFB Detection Mode, one for each 32-channel audio engine.)

When selected for VOX, interrupt activity is detected when voice-band audio is present within the interrupt audio channel. Specifically, audio content from approximately 225 to 1250 Hz at a level of –44 dBFS or greater would be detected as being active.

When selected for TOX, interrupt activity is present when high-frequency audio content is detected in the interrupt audio channel. Essentially any sine-wave or square-wave signal with a frequency in the range of 15 to 22 kHz and a signal level of approximately –22 dBFS or greater can serve as the control signal.

There are a number of different ways that a compatible high-frequency audio signal can be created. Several Studio Technologies’ products will generate an 18 or 20 kHz sine-wave that is part of a Dante transmitter (output) signal. For example, each button on the Model 348 Intercom Station can be independently configured to cause an 18 or 20 kHz tone to be generated. The Model 44D Interface allows a contract closure to generate a 20 kHz tone that’s part of a Dante transmitter (channel). It’s also expected that Studio Technologies will offer a simple product that will allow contract closures (GPI signals) to cause high-frequency sine-wave tones to be generated on Dante transmitter (output) channels. In this way, legacy products that offer contact closure (or even logic signals) can be used to control one or more Model 5422A Audio Switching sections.

#### ***IFB Dim Level***

Choices are: 0 dB, 10 dB, 15 dB, 20 dB, Full Mute

This value determines the amount of attenuation that will be applied to the Dante program audio input source when the IFB function is active. When 0 dB is selected the level of the program audio channel will not change when interrupt is active. The interrupt audio will simply be added (mixed or summed) with the program audio. When Full Mute is selected the program audio source level will fully attenuate whenever interrupt activity is detected. When 10 dB, 15 dB, or 20 dB is selected the program audio source will dim (attenuate or reduce in level) by the amount selected. For most broadcast applications 15 dB would be the appropriate setting.

The IFB Dim Level setting applies to all IFB sections that are established within a specific audio engine. (In the Model 5422A-02 there would be two settings for the IFB Dim Level, one for each 32-channel audio engine.)

**Audio Switching:** This operating mode allows one Dante receiver (input) audio signal to be routed between two Dante transmitter (output) channels. One output is normally on (active) and the other normally off (inactive). When an associated control signal is off (not active) audio data associated with the audio input is routed to the normally on audio output; no audio data is sent to the normally off audio output. When an associated control signal is on (active) the audio input data is routed to the normally off audio output; no audio data is sent to the normally on audio output. The switching is performed in a “click-free” manner, ensuring “clean” transitions between the normally on and normally off Dante transmitter (output) channels.

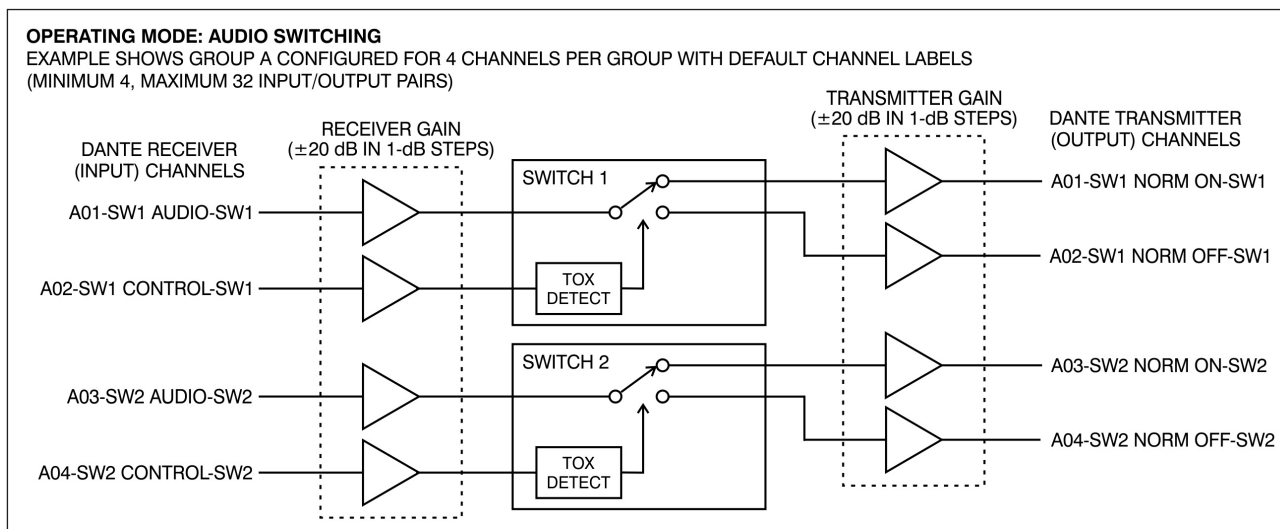

An independent control signal determines which output is active. The control signal arrives in the form of a separate Dante receiver (input) audio channel. The state of the control signal is based on a tone-operated (TOX) function. This function is the same as utilized by the IFB operating mode when selected for TOX mode.

From the electrical world the Audio Switching operating mode can be considered to be a function that emulates a single-pole-double-throw relay or switch contact. It might also be thought of as being similar to a form-C relay contact. However, a significant difference is that the audio path is not bi-directional. Audio arrives on a Dante receiver (input) channel and exits via one or the other of the two Dante transmitter (output) channels.

Each Audio Switching section uses two Dante receiver (input) channels and two Dante transmitter (output) channels. One Dante receiver (input) channel is the audio signal that is routed (connected) to either the normally on and normally off Dante transmitter (output) channels. The second Dante receiver (input) channel is considered to be the control channel.

The Audio Switching operating mode can be useful for a variety of audio switching, routing, or muting functions. One or more Dante audio channels can be routed to two destinations. As an example, this could be useful for applications such as supporting two multi-channel loudspeaker systems.

The Audio Switching operating mode can also be used to control the on/off state of one or more Dante audio signals. In this way, a multi-channel audio muting group could be easily created. In all cases the switches will be “click free,” changing states without audio artifacts.

As previously discussed, each Audio Switching section incorporates an independent tone-operated (TOX) detection resource, utilizing a high-frequency audio signal as a reliable means of selecting the on or off state. The same control signal source can be used with one or more Audio Switching sections.

The number of Audio Switching sections provided by a Model 5422A group depends on the selected group size. A group size of 4 would provide 2 independent Audio Switching sections. A group size of 32 would provide 16 independent Audio Switching sections.

It’s simple to create a multi-channel audio switching or muting function. In this way, a multi-channel audio signal, such as audio channels associated with a 5.1 or 7.1.4 surround format, can be controlled using just one control signal. Begin Model 5422A configuration by selecting the group size needed to support the required number of Audio Switching sections. For example, to support a 7.1.4 signal one would need 12 sections (7+1+4) which would in turn require a 24-channel group. As such, selecting a channels-per-group configuration of 24, 8 would make

sense. This would make Group A consist of 24 channels and select Audio Switching as its operating mode. Using Dante Controller route (Dante subscribe) the Dante transmitter (output) sources associated with the 7.1.4 signal to the 12 audio inputs associated with the 12 Audio Switching sections. Depending on the desired application, use Dante Controller to route (Dante subscribe) the 12 normally on or 12 normally off signals to the desired Dante receiver (input) channels on the designated audio equipment. Finally, route (Dante subscribe) the one Dante control signal to all 12 control inputs on the 12 Audio Switching sections. There is no problem using the same Dante transmitter (output) channel and routing it to multiple inputs. That is all that is required. Now, voila, a single control signal will simultaneously control 12 audio channels!

## Channel Configuration

The Channel Configuration webpage associated with each audio engine considers a “channel” to consist of both a Dante receiver (input) and a Dante transmitter (output) channel. These channel pairs typically share a common label (name) that can be revised as desired for an application. The gain of the receiver (input) and transmitter (output) paths can also be independently configured. This “trim” capability can be useful, ensuring that the nominal level of the audio paths that route between the Model 5422A and other Dante-compatible equipment is optimal.

Channel	Channel Label (Rx/Tx)	Receiver (Input) Gain (±dB)*	Transmitter (Output) Gain (±dB)*
01	A01-Group A- Ch1	0	0
02	A02-Group A- Ch2	0	0
03	A03-Group A- Ch3	0	0
04	A04-Group A- Ch4	0	0
05	A05-Group A- Ch5	0	0
06	A06-Group A- Ch6	0	0
07	A07-Group A- Ch7	0	0
08	A08-Group A- Ch8	0	0
09	B01-Group B- Ch1	0	0
10	B02-Group B- Ch2	0	0
11	B03-Group B- Ch3	0	0
12	B04-Group B- Ch4	0	0
13	B05-Group B- Ch5	0	0
14	B06-Group B- Ch6	0	0

**Channel Label (Rx/Tx):** As previously discussed in this guide, Dante Controller can be used to edit channel labels. When using Dante Controller, separate entries are required for the receiver (input) and transmitter (output) channel labels. This would lead to needing to edit up to 64 entries (32 input and 32 output) for each Model 5422A audio engine. However, each audio engine’s Channel Configuration webpage provides a “smart” channel labeling method, making audio channel routing (Dante subscribing) and identifying channels on a network clear and easy to manage. Using this method only one label has to be specified for each channel pair.

Each label is made up of three sections: a unique prefix, a group label, and an individual channel label. The prefix is three characters long. The first character shows which group the channel belongs to (A thru H for audio engine 1; J thru R for audio engine 2). The next two characters provide a numerical index that identifies the channel number in the group.

After a delimiting dash (-) the group label is appended to the unique prefix. When a group is configured for the Party-

Line w/Auto Mix, Party-Line, Summing Bus w/Auto Mix, Summing Bus, or Pass Thru operating modes, the group labels can be configured as desired. The default label is Group A for Group A, Group B for Group B, etc. Selecting and entering commonly utilized group labels can be useful for identifying specific Model 5422A functions. This might include Production, Engineering, Lighting, etc. These group labels can be up to 14 characters in length.

The group labels are not configurable for the IFB and Audio Switching operating modes. In these modes a group label is used to define which IFB or Audio Switch channel pair the channel belongs to within the group and the function of each channel. For example, IFB1 for channels 1 and 2 in an IFB group or SW2 for channels 3 and 4 in an Audio Switching group. Following the channel-pair identifier label the specific function of the channel is shown. This will be Int In or Pgm In for the IFB receiver (input) channels and Pgm+Int or Non Int for the IFB transmitter (output) channels. For the Audio Switching operating mode the labels would be Audio or Control for the receiver (input) channels and Norm On or Norm Off for the transmitter (output) channels.

Lastly, an individual channel label can be appended to the Dante Channel Label. This is handled on the Audio Engine Channel Configuration webpage for each audio engine. The second column in the table shows the complete channel label and includes a text input box that can be used to view or change the individual channel label. Up to 12 characters can be entered. Dante receiver (input) and transmitter (output) channels in the Party-Line, Summing Bus, and Pass Thru operating mode groups have identical channel labels. The default individual channel labels for the non IFB and Audio Switching groups are Ch1, Ch2, Ch3, etc. This field can be used to label each channel with its intended user. i.e. Talent 1, Play-by-Play, Larry, Sergio, etc.

For the IFB and Audio Switching operating mode groups a single channel label is applied to each channel pair. This is because each IFB and Audio Switching section is comprised of two input and two output channels. The default labels for these groups, for example, are IFB1 and SW2.

As previously discussed, channel labels can also be edited using the Dante Controller software application. But information entered using Dante Controller is not passed to the Model 5422A's webpage interface. This data could be overwritten when modifying channel labels from the M5422A's webpages. Using the Clear Config function within Dante Controller will erase all Dante channel labels in the Model 5422A. It is recommended to subsequently use the restore factory defaults in the Model 5422A's system webpage to re-populate the "smart" channel labels in the unit. Also note, changing the Channels per Group setting on the Audio Engine Group Configuration page will reset all associated Dante channel labels and will force all audio routes (Dante subscriptions) to be removed.

The Channel Configuration webpages have multiple Submit buttons. These are provided adjacent to entry fields and should be activated each time a change has been made. Changes will not be stored if the appropriate Submit button has not been "pressed."

**Receiver (Input) Gain ( $\pm$ dB):** The nominal level of each Dante receiver (input) channel can be adjusted over a range of  $\pm$ 20 dB in 1-dB steps. Adjust the level as desired to optimize the performance of an application. Consider carefully whether a channel's receiver gain really needs to be adjusted! In most cases, maintaining the default value (0 dB) will be optimal. Adding gain (a positive number) can reduce the headroom available to a signal within both the Model 5422A and the overall system. Attenuating the signal (a negative number) can slightly increase the noise floor of the overall system. A Submit button, located on the far right of each row, must be used to store a gain change.

**Transmitter (Output) Gain ( $\pm$ dB):** The nominal level of each Dante transmitter (output) channel can be adjusted over a range of  $\pm$ 20 dB in 1-dB steps. Adjust the level as desired to optimize the performance of an application. Consider carefully whether a channel's transmitter gain really needs to be adjusted! In most cases, maintaining the default value (0 dB) will be optimal. Adding gain (a positive number) can reduce the headroom available to a signal within both the Model 5422A and the overall system. Attenuating the signal (a negative number) can slightly increase the noise floor of the overall system. A Submit button, located on the far right of each row, must be used to store a gain change.

## Network Menu

There are seven display-only fields that relate to the key parameters that are associated with the Dante and management Ethernet interfaces. Four additional fields allow management interface parameters to be configured.

The screenshot displays the Network configuration page for the Model 5422A-02 Dante Intercom Audio Engine. The page is titled "Model 5422A-02 Dante Intercom Audio Engine" and includes a "Log Out" button. The "Network" tab is selected, showing the following configuration details:

Dante Interfaces	
Primary IP Address	192.168.1.144
Secondary IP Address	Disabled
Switch Configuration	Switched+Mgmt

Management Interface	
MAC Address	00-04-22-F1-27-0F
Current IP Address	192.168.1.132
Current Subnet Mask	255.255.255.0
Current Gateway	192.168.1.1
IP Address Configuration	Automatic
Manual IP Address	<input type="text" value="192.168.1.22"/>
Manual Subnet Mask	<input type="text" value="255.255.255.0"/>
Manual Gateway	<input type="text" value="192.168.1.1"/>

A "Submit" button is located at the bottom of the Management Interface section. The footer of the page reads "Studio Technologies, Inc."

### Dante Interfaces

The three display-only fields in the Dante Interfaces section will show the IP addresses associated with the Model 5422A's Dante primary and Dante secondary ports, along with the configuration of the Model 5422A's Ethernet switch integrated circuit.

**Primary IP Address and Secondary IP Address:** The Dante primary IP address field will show either No Ethernet Link or an IP address. The Dante secondary IP address field will show Disabled, No Ethernet Link, or an IP address. No Ethernet Link will display if an Ethernet connection has not been made to the appropriate RJ45 jack on the Model 5422A's back panel. Disabled will show if Dante redundancy has not been enabled in the Dante Controller application. The 32-bit IPv4 addresses will be displayed in what's known as dot-decimal notation (4 octets, each separated by a dot).

How the IP addresses are assigned will depend on the Model 5422A's network configuration setting as performed using the Dante Controller application. Each IP address can be established automatically using a DHCP server or the IPv4 link-local protocol. An IP address assigned to the Dante primary interface by link-local will have a format of 169.254.x.x. An IP address assigned to the Dante secondary interface by link-local will have a format of 172.31.x.x.

The Dante primary and secondary IP addresses can also be individually set to manual (static or fixed) IP addresses using the Dante Controller application.

If the network configuration is selected for Switched the Dante primary IP address will be associated with a network connection made to either the Dante primary or Dante secondary RJ45 jack on the Model 5422A's back panel. No Ethernet Link will display if no connection is present. The IP address for the Dante secondary interface will show Disabled as it is not being utilized in this network mode. The management IP address will be associated with a network connection made to the management RJ45 jack on the Model 5422A's back panel.

If the network configuration is selected for Redundant then the Dante primary IP address will be associated with the RJ45 jack labeled PRI on the Model 5422A's back panel. No Ethernet Link will display if a valid Ethernet connection has not been made to the Dante primary Ethernet interface. The Dante secondary IP address will be associated with the RJ45 jack labeled SEC on the Model 5422A's back panel. No Ethernet Link will display if a valid Ethernet connection has not been made with the Dante secondary Ethernet interface. The management IP address will be associated with a network connection made to the RJ45 jack labeled MGMT on the Model 5422A's back panel.

If the network configuration is selected in Dante Controller for Switched+Mgmt then the Dante primary IP address will be associated with a network connection made to either the Dante primary or the Dante secondary RJ45 jack on the Model 5422A's back panel. The IP address field for the Dante secondary interface will show Disabled as it is not being utilized. The management IP address will be associated with a network connection made to either the Dante primary or Dante secondary RJ45 jack.

If the network configuration is selected for Redundant+Mgmt then the Dante primary IP address will be associated with a connection made to the RJ45 jack labeled PRI on the Model 5422A's back panel. No Ethernet Link will display if a valid Ethernet connection has not been made. The Dante secondary IP address will be associated with an Ethernet connection made to the RJ45 jack labeled SEC on the Model 5422A's back panel. No Ethernet Link will display if a valid Ethernet connection has not been made with the Dante secondary Ethernet interface. The management IP address will be associated with a network connection made to the Dante primary RJ45 jack located on the Model 5422A's back panel.

If the Model 5422A's network configuration in Dante Controller is selected for Switched or Switched+Mgmt ensure that only one of the RJ45 jacks on the back panel is connected to the LAN associated with the Dante devices. The other RJ45 jack can be used to interconnect with another piece of networked equipment. But having both the Model 5422A's Dante primary and Dante secondary RJ45 jack routed to ports on the same LAN will typically "crash" the network!

**Switch Configuration:** This is a display-only field that shows the Model 5422A's network configuration as determined by a setting in the Dante Controller application. The term "Switch" refers to an Ethernet switching and routing integrated circuit that is part of the Model 5422A's hardware. How this integrated circuit is configured determines how the Model 5422A's three GigE Ethernet ports will function. The field will show Switched, Redundant, Switched+Mgmt, or Redundant+Mgmt. It will also display Error in the unlikely event that an error in the Dante interface circuit, provided by a Brooklyn II module, has occurred.

### Management Interface

There are eight fields that relate to the Model 5422A's management interface. Four are display-only and four allow configuration settings to be selected. They don't have any relation to the Dante primary and Dante secondary IP addresses and their associated network parameters

**MAC Address:** This display-only field shows the MAC (media access control) address associated with the network interface controller (NIC) devices used for the management

port. This is a fixed hardware address that is assigned to the management Ethernet port. Every MAC address is unique among all Ethernet ports and cannot be changed. The Model 5422A displays a MAC address as six groups of two hexadecimal digits, separated by hyphens.

**Current IP Address:** This display-only field shows the IP address value associated with the management port. It will be displayed in dot-decimal notation. When the IP address has been obtained using link-local the current IP address value will always be something in the range of 169.254.x.x.

**Current Subnet Mask:** This display-only field shows the subnet mask value associated with the management port. The subnet mask value will display in dot-decimal notation. When the management port's current IP address has been obtained using link-local the subnet mask value will always be 255.255.0.0.

**Current Gateway:** This display-only field shows the gateway IP address associated with the management port. The gateway value will be displayed in dot-decimal notation. When the management port's IP address has been obtained using link-local a gateway value will not be assigned.

**IP Address Configuration:** This is a configurable field with two choices: Automatic and Manual.

The selected configuration impacts how the Model 5422A obtains the IP address that is used for accessing the management web server and associated menu webpages. This setting has no impact on how the Model 5422A obtains IP addresses for the primary and secondary Dante IP interfaces.

Selecting the Automatic setting causes the Model 5422A to use the DHCP or, if DHCP is not available, the IPv4 link-local protocol to establish the IP address for the Model 5422A's management port. When selected to use Automatic, upon establishing a connection to the configured Model 5422A RJ45 jack the DHCP protocol will request an IP address and related parameters. If obtaining an IP address in this manner is not successful then the IPv4 link-local protocol will be used. (If an IP address has the format of 169.254.x.x then it was assigned using IPv4 link-local.) Even if the IP address was established using link-local the DHCP protocol will remain active. In this case, approximately every 30 seconds the Model 5422A's firmware will check for the presence of a DHCP server. If one becomes available then an IP address will be requested and, when obtained, will automatically replace the IP address that was previously established by link-local.

The Manual setting allows the desired IP address and related parameters to be manually entered. This can be useful

when a fixed addressing scheme has been established. In this way, a static IP address can be entered along with the other important network parameters.

When selected for Automatic the fields for the manual IP address, manual subnet mask, and manual gateway will be “grayed out” (will have a gray background) to indicate that their values cannot be manually changed. In this condition they are display-only. Changing between Automatic and Manual and vice-versa will not impact the values stored for the manual IP address, manual subnet mask, and manual gateway fields.

Note that to minimize the chance of losing access to the management web server, restoring the Model 5422A’s default configuration values will not change the currently selected IP address configuration choice.

**Manual IP Address:** This field shows the stored IP address associated with the management web server when the manual mode has been selected for the IP address configuration. This address has nothing to do with the IP address utilized by the primary and secondary Dante ports. When IP address configuration is selected for Automatic this field is grayed out and the value cannot be revised. Whenever the IP address configuration is selected for Manual the manual IP address can be modified as desired to meet the requirements of the application. After entering an IP address, using the standard dot-decimal notation, the Submit button at the bottom of the webpage must be pressed for the changes to be stored. A system reboot is required for the revised manual IP address to be utilized. The Reboot function is available on the System webpage and by way of a front-panel menu. Restoring the Model 5422A to its default values will not change the stored manual IP address.

**Manual Subnet Mask:** This field shows the stored subnet mask value associated with the management web server when the manual mode has been selected for the IP address configuration. When the IP address configuration is selected for Automatic this field is grayed out and the value cannot be revised. When the IP address configuration is selected for Manual this field will not be grayed out and the value can be modified as desired to meet the requirements of the application. After entering a revised manual subnet mask value, using the standard dot-decimal notation format, the Submit button must be pressed for the change to be stored. A system reboot is required for the revised manual subnet mask value to be utilized. Restoring the Model 5422A’s default values will not change the stored manual subnet mask value.

**Manual Gateway:** This field shows the stored gateway value associated with the management web server when the manual mode has been selected for the IP address configuration. When IP address configuration is selected for Automatic the manual gateway field is grayed out and the value cannot be revised. When the IP address configuration is selected for Manual this field will not be grayed out and the value can be modified as desired. After entering a revised manual gateway value, using dot-decimal notation, the Submit button must be pressed for the change to be stored. A system reboot is required for the revised manual gateway value to be utilized. Restoring the Model 5422A’s default values will not change the stored manual gateway value.

**Submit:** The Submit button is located at the bottom of the Management Interface area of the Network menu webpage. To save any changes made to four fields in the Management Interface area requires that the Submit button be pressed. To utilize those changes requires that a Model 5422A reboot to take place. That can occur by using the system Reboot function on the System webpage or by way of a selection from one of the menus on the front panel.



## Access Menu

As a security method both a valid user name and password must be entered before the configuration webpages can be accessed. (This is what you did to get this far!) These values can be changed as desired.

The Model 5422A's access security method is in no way rigorous. The user name and password are sent to and received from the Model 5422A as plain text. They are also stored within the Model 5422A as plain text. There is no security method or encryption associated with these fields. Anyone "snooping" on the LAN that is transporting Model 5422A management data will see all values in plain text. The ability to select a "custom" user name and password pair is intended simply to provide a means of keeping "honest" users from easily changing the configuration of a Model 5422A. If unauthorized access is of concern, then it's recommended that the Model 5422A's network configuration be selected for Switched or Redundant. And then an Ethernet connection to the Model 5422A's management RJ45 jack should not be present except when menu-system access by authorized personnel is desired.

The default user name is **guest** and the default password is **guest**. These are case sensitive. If neither of the default entries are changed then they will display in the User Name and Password entry fields on the Login menu webpage. If the default user name and/or default password are changed then neither the user name nor the password will display upon accessing the Login menu webpage.

### Management Log Credentials

**User Name:** In this field a revised user name can be entered. The user name must be a minimum of five characters, a maximum of 15 characters, and is case sensitive. All 95 of the printable ASCII characters can be used. These include upper and lower alphabetic characters, numbers, and standard punctuation marks.

**New Password:** In this field a revised password can be entered. The password must be a minimum of five characters, have a maximum of 15 characters, and is case sensitive. All 95 of the printable ASCII characters can be used. These include upper and lower alphabetic characters, numbers, and standard punctuation marks.

**Confirm New Password:** For a new password to be considered valid, enter it identically into this field.

**Submit:** The Submit button is located below the field for Confirm New Password. To save changes made to the User Name and/or New Password fields requires that the Submit button be pressed. Changes made will be effective upon the next attempt at logging into the Model 5422A. Restoring the Model 5422A to its default values does not change the stored user name and password.

## System Menu

This menu provides five display-only fields as well as functions that allow the unit's default settings to be restored and the system to be rebooted (restarted).

One of the display-only fields shows the hardware serial number and the remaining four provide details about the firmware (embedded software) that is being actively utilized by the Model 5422A.

Version Information		
	Version	Date
Main Firmware	1.00	10 Feb 2021
FPGA Firmware	2.01	07 Dec 2020
Dante Product	1.0.0	21 Jan 2021
Dante Firmware	4.2.0.28	---

**Serial Number:** This is a display-only field that shows the Model 5422A's hardware serial number. This number has been assigned at the factory and cannot be changed.

### Version Information

The version information section consists of four rows of information that provide details about the firmware (embedded software) files that are currently being used by the Model 5422A. These are display only and will include a date if that is specified as part of the firmware release.

**Main Firmware:** This display-only field shows the version number and associated release date of the Model 5422A's Main firmware. This firmware can be field-updated using a USB flash drive. Update details are provided in the Technical Notes section of this guide.

**FPGA Firmware:** This is a display-only field that shows the version number and associated date of the Model 5422A's FPGA (field-programmable-gate-array) firmware. This firmware can be field-updated using a USB flash drive. Update details are provided in the Technical Notes section of this guide.

**Dante Product:** This display-only field shows the product version number and associated date that's stored in and being utilized by the Dante interface. (The Dante interface is implemented using a Brooklyn II module from Audinate.) This version number is assigned by Studio Technologies as an identifier when a file is released that combines specific Model 5422A configuration information along with Dante operating firmware. The firmware for the Model 5422A's Dante interface can be updated by way of an Ethernet connection using the Dante Updater software application that's provided as part of the Dante Controller software application.

**Dante Firmware:** This is a display-only field that shows the version number of the firmware associated with the Dante interface (Brooklyn II module) that the Model 5422A utilizes for Dante interconnectivity. No date is associated with this file. The displayed version number is assigned by Audinate and can't be changed by Studio Technologies. It is incorporated into the Dante Product (.dnt) file that is released by Studio Technologies specifically for the Model 5422A. As noted previously, this firmware, part of the Dante product firmware, can be updated by way of an Ethernet connection using the Dante Updater software application.

## **Restore Default Settings**

The Restore Default Settings function allows many of the Model 5422A's default configuration settings to be restored. However, it will not impact the network configuration or user name and password settings. For the defaults to be restored the associated check box must be enabled prior to pressing the Submit button. Be careful when using this function as invoking it after enabling the check box will immediately cause the defaults to be restored. Refer to Appendix D for a list of the default values.

## **System Reboot**

The Reboot function is located on the bottom of the System menu webpage. It allows the Model 5422A to be rebooted (restarted) without having to perform a power cycle. (The function can be considered to invoke a "cold boot.") For a system reboot to take place the check box must be enabled prior to pressing the Reboot button. During normal operation a system reboot will never be required. But after changes are made to any of the unit's management interface network configuration a reboot is required. A system reboot will cause the three Ethernet interfaces to go through a reconnection process, necessary should any of the management network parameters be revised. (These changes can be made by way of the Network menu choices or using the front-panel display and buttons.)

## Menu Text and Links

The following provides details on some of the text and links that are presented on each of the Model 5422A's webpages.

**Device Name:** In the upper-right corner of each Model 5422A webpage is the Dante device name. This name is unique to each device in a Dante deployment and is used as part of the channel routing (Dante subscribing) process. The name can be changed from within the Dante Controller application.

**Identify Device Link:** In the upper-right corner of each webpage, directly below the device name, is a link called Identify Device. Clicking on it will cause the Dante identify action to commence on the specific Model 5422A. On the unit's front panel, the identify action will cause the front-panel display's backlight to flash five times. On the back panel, the identify action will cause the LEDs associated with the primary and secondary Dante ports to flash approximately eight times. The identify command will help confirm that the desired Model 5422A is being accessed. Note that the Dante Controller application also allows invoking of the identify command.

**Company Name Link:** On the bottom of each webpage is a link with the title Studio Technologies, Inc. Clicking on this link will cause the browser to open the Home webpage of the Studio Technologies website.

**Log Out Link:** In the upper-right edge of most of the Configuration menu webpages is a link called Log Out. It will cause the Model 5422A's web server to end the session, logging out the user and returning to the basic Home menu. To again access the configuration webpages requires that the user click on the Login tab and provide a valid user name and password.

## Operation

Now that the Model 5422A is installed and configured it's ready for use. Normally no operator intervention should be required. However, there are a number of nuances in the unit's operation. This may make it useful for technical personnel to spend some time reviewing this section of the guide.

Upon application of AC mains or DC power, the Model 5422A will go through several power-up sequences. The LED associated with the USB receptacle on the unit's back panel will briefly light green to indicate that it is functioning. The LEDs associated with the Model 5422A's three Ethernet jacks will flash several times as part of the associated Ethernet interface integrated circuit's power up action. The seven LEDs on the unit's front panel will first light green, then light red in a confirmation sequence. While the LEDs

are going through their power-up sequence the front-panel display will first show the unit's model number (Model 5422A) and Dante device name. Then the screen will show the unit's main firmware version number. After a few seconds the Studio Technologies' logo will display followed by the screen saver mode becoming active. Details about the screen saver mode are covered later in this guide.

After the Model 5422A has completed its power-up sequences full operation will begin. The Model 5422A's front panel contains seven bi-color LEDs which reflect the real-time status of unit's major functions. The two power LEDs indicate the presence of incoming AC mains and 12 volts DC power. They are labeled AC and DC. When a source of AC mains power is connected the AC LED will light green. The DC LED will light green whenever a connected DC source exceeds approximately 10 volts. The DC LED will light red when the DC input is between approximately 9 and 10 volts, indicating a low-voltage condition. If the DC input is less than approximately 9 volts the DC LED will not light and the Model 5422A will no longer operate from the DC source.

Two LEDs are associated with the Model 5422A's Dante interface. The system LED, labeled SYS, and the synchronization LED, labeled SYNC, will both light red as the unit's Dante interface starts to function and awaits connection to the associated LAN or LANs. The system LED will light red to indicate that the interface is not ready to pass data to other devices. It will blink red if there is an issue communicating with the internal Dante Brooklyn II module. (This should never occur unless there is a Model 5422A hardware problem.) It will light green when it is operating normally and is ready to pass data.

The synchronization LED will light red to indicate that the Model 5422A's Dante interface has not established timing synchronization. It will light solid green when it has synchronized with a Dante network and an external clock source (timing reference) is being received. The synchronization LED will slowly flash green if this specific Model 5422A is part of a Dante network and is serving as the Leader Clock. (In this case, it's likely that other Dante devices are following this Model 5422A which is acting as their timing reference.) It's possible that up to 30 or 40 seconds may be required for the synchronization LED to reach its final state.

Two LEDs are associated with the Model 5422A's Dante primary and Dante secondary Ethernet connections. They are labeled PRI and SEC. How they respond will depend on the unit's network configuration as made in the Dante Controller application

When the Dante interface has been configured for Switched operation the primary LED will light red when no Ethernet connection is present. It will light green when a Gigabit

Ethernet (GigE) connection is present. It will light orange when a 100 Mb/s Ethernet connection is present. The secondary LED will not light when an Ethernet connection is not present. It will light green when a GigE or a 100 Mb/s Ethernet connection is present.

When the Model 5422A's Dante interface has been configured for Redundant operation the primary and secondary LEDs will light red when Ethernet connections are not present on their respective RJ45 jacks. Each will light green when a Gigabit Ethernet (GigE) connection has been made and orange when a 100 Mb/s Ethernet connection has been made.

One LED is associated with the Model 5422A's management Ethernet connection. The LED, labeled MGMT, will not light if an Ethernet connection has not been made. It will light green if a GigE or a 100 Mb/s Ethernet connection has been made.

### RJ45 LED Indicators

On the Model 5422A's back panel there are three RJ45 jacks that are provided for interfacing with the unit's three Gigabit Ethernet (GigE) ports. Two of the jacks are designated for Dante audio use and the third for management functions. The three RJ45 jacks are labeled Dante PRI, Dante SEC, and MGMT. Associated with each jack are two LEDs. One LED is labeled LINK and lights orange when a GigE connection has been established with that specific jack. The LINK LED will not light if a 100 Mb/s Ethernet connection has been made. It will also not light if an Ethernet connection has not been made. The second LED, labeled ACT, will flash green to indicate data activity, responding to Ethernet traffic traveling to and from that specific jack.

### Front-Panel Display Page Descriptions

The following sections provide information about the Model 5422A's front-panel menu pages. Additional details can be found in the Model 5422A Configuration section of this guide. Refer to Appendix C for the menu structure diagram.

#### Row One

Row one has five front-panel menu pages that involve the management IP address and related parameters. Two menu pages are display-only and the other three, by default, allow changes to be made.

**Current Management IP Address:** This menu page will show the IP address associated with the Model 5422A's internal management web server. This address can be assigned automatically using the DHCP protocol or, if a DHCP server is not available, using the IPv4 link-local protocol. (An IP address that has the format of 169.254.x.x was assigned using IPv4 link-local.) The management IP address can also be manually assigned with a fixed or

static IP address. If no Ethernet connection has been made the text No Ethernet Link will be displayed.

If the Model 5422A's network configuration in the Dante Controller application is selected for Switched or Redundant then this menu page will show the IP address that's associated with the connection made to the Model 5422A's management RJ45 jack.

If the Model 5422A's network configuration in the Dante Controller application is selected for Switched+Mgmt then the IP address that is displayed will be associated with a connection that is made to either the Dante primary or Dante secondary Ethernet jack.

If the network configuration in Dante Controller has been selected for Redundant+Mgmt then the IP address that is displayed will be associated with a connection that is made to the Dante primary Ethernet jack.

**Current Management Subnet Mask:** This menu page will show the subnet mask value that is active for the management interface and associated web server. If the IP address and related network parameters were obtained by way of DHCP then this field will display an IPv4 subnet mask value in dot-decimal notation. If the IP configuration mode is selected for Automatic and the current IP address was obtained by way of link-local, then 255.255.0.0 will show. It's also possible that the subnet mask value was manually entered as part of a fixed or static IP address setting.

**Management IP Configuration:** This menu page allows the display and revision of the method that the Model 5422A will use to obtain a management IP address and related parameters. The choices are Automatic and Manual. The selected configuration impacts how the Model 5422A obtains the IP address that is used for accessing the management web server and associated menu webpages. This setting has no impact on how the Model 5422A obtains IP addresses for the Dante primary and Dante secondary Ethernet interfaces.

An arrow icon will display in the upper-right corner of this menu page. This indicates that the setting can be changed. If the active method is not the desired one, press the Enter pushbutton switch located on the front panel. Use the left and right arrow buttons to select (highlight) the desired method. Then again press the Enter button. The entry will be stored. To cause the Model 5422A to use the new setting requires that the Model 5422A be rebooted (restarted). This can be performed using another front-panel menu page, a selection in one of the management webpages, or by power cycling the unit.

Selecting the Automatic setting causes the Model 5422A to use DHCP or, if DHCP is not available, the IPv4 link-local protocol to establish the IP address for the management

port. Even if the IP address was established using link-local the DHCP protocol will remain active. In this case, approximately every 30 seconds the Model 5422A's main firmware will check for the presence of a DHCP server. If one becomes available then an IP address will be requested and, when obtained, will automatically replace the IP address that was previously established by link-local.

The Manual setting allows the desired IP address and related parameters to be manually entered. This can be useful when a fixed or static addressing scheme has been established. In this way, a designated IP address can be entered along with the other necessary network parameters.

Note that to minimize the chance of losing access to the management web server, restoring the Model 5422A's default configuration values will not change the currently selected IP address configuration choice.

**Manual Management IP Address:** This menu page shows the stored IP address associated with the connection used to access the management web server. (This address has nothing to do with the IP addresses utilized by the Dante primary and Dante secondary Ethernet interfaces.) It will be utilized only when the manual mode has been selected for the management IP address configuration. When the IP address configuration has been selected for Automatic this field cannot be changed and a lock icon will show in the upper-right corner of the display.

Whenever the IP address configuration is selected for Manual the manual IP address can be modified as desired. This will be indicated by an arrow icon that will show in the upper-right corner of the display. To start the process of changing the manual management IP address press the Enter pushbutton switch on the front panel. An icon with a wrench and screwdriver will display to indicate that an edit is in process. Use the left and right arrow pushbutton switches to select which specific digit of the IP address number is to be modified. Press the up and down arrow pushbuttons to select the desired number. The standard dot-decimal notation is used to display and revise the IP address. Once all the desired changes have been made press the Enter button to store them.

To cause the Model 5422A to use the new setting requires that the unit be rebooted (restarted). This can be performed using another front-panel menu page, using a function on a management webpage, or by power cycling the unit. Restoring the Model 5422A to its default values will not change the stored manual IP address.

**Manual Management Subnet Mask:** This menu page shows the stored subnet mask value associated with the connection used to access the management web server. (This value has nothing to do with the subnet mask values

utilized by the Dante primary and Dante secondary ports.) It will be utilized only when the manual mode has been selected for the management IP address configuration. When the IP address configuration has been selected for Automatic this field cannot be changed and a lock icon will show in the upper-right corner of the display.

Whenever the IP address configuration is selected for Manual the manual management subnet mask value can be modified as desired. This will be indicated by an arrow icon that will show in the upper-right corner of the display. To start the process of changing the subnet mask value press the Enter pushbutton switch on the front panel. An icon with a wrench and screwdriver will display to indicate that an edit is in process. Use the up and down arrow pushbutton switches to select the desired subnet mask value. Once the desired value has been selected press the Enter button to store it.

To cause the Model 5422A to use the new manual management subnet mask value requires that the unit be rebooted (restarted). This can be performed using another front-panel menu page, using a function on a management webpage, or by power cycling the unit. Restoring the Model 5422A to its default values will not change the stored subnet mask value.

## Row Two

Row two has a total of six menu pages which relate to the Model 5422A's Dante device name, Dante network configuration, Ethernet switch configuration, and Dante reboot (restart) status. Two menu pages are display-only, three allow configuration changes, and one can be used to reboot (restart) the Dante interface.

**Dante Device Name:** The Dante device name is shown on this menu page. This name is unique to each device in a Dante deployment and is used as part of the channel routing (Dante subscribing) process. The name can be changed from within the Dante Controller application. The text shown on this menu page is the same as is shown in the upper-right corner of each Model 5422A management webpage.

**Dante Primary IP Configuration:** This menu page allows the display and revision of the method that the Model 5422A's Dante interface uses to obtain the Dante primary IP address and related parameters. The choices are Automatic and Manual. This setting has no impact on how the Model 5422A obtains IP addresses for the Dante secondary interface and management interface webpages.

An arrow icon will display in the upper-right corner of this menu page. This indicates that the setting can be changed. If the active method is not the desired one, press the Enter pushbutton switch located on the front panel. Use the left

and right arrow buttons to select the desired method. Then again press the Enter button. The entry will then be stored. To cause the Model 5422A to use the new setting requires that the unit be rebooted (restarted). This can be performed using another front-panel menu page, a selection in one of the management webpages, or by power cycling the unit.

Selecting Automatic will cause the Model 5422A's Dante interface to use DHCP or, if DHCP is not available, the IPv4 link-local protocol to establish the IP address used by the Dante primary interface. (An IP address that has the format of 169.254.x.x was assigned using IPv4 link-local.) Even if the IP address was established using link-local the DHCP protocol will remain active. In this case, the Model 5422A's Dante interface will continue to check for the presence of a DHCP server. If one becomes available then an IP address will be requested and, when obtained, will automatically replace the IP address that was previously established by link-local.

The Manual setting allows the desired Dante primary IP address and related parameters to be manually entered. This can be useful when a fixed or static addressing scheme has been established. In this way, a designated IP address can be entered along with the other necessary network parameters.

To cause the Model 5422A to use a revised Dante primary IP address configuration method requires that the unit's Dante interface be rebooted (restarted). This can be performed using the reboot Dante front-panel menu page or by rebooting (restarting) the entire Model 5422A. This latter action can be accomplished using the reboot device menu page, using a function on one of the management webpages, or by power cycling the Model 5422A.

Note that to minimize the chance of losing access to the Dante network, restoring the Model 5422A's default configuration values will not change the stored Dante primary IP address configuration method.

**Dante Primary IP Address:** This menu page shows the IP address associated with the Dante primary interface. (This address has nothing to do with the IP addresses utilized by the Dante secondary and management interface ports.) When the IP address configuration has been selected for Automatic this field cannot be changed and a lock icon will show in the upper-right corner of the display. It can be revised only when the manual mode has been selected for the Dante primary IP configuration.

If no Ethernet connection has been made the text No Ethernet Link will be displayed. If the network configuration is selected in the Dante Controller application for Switched or Switched+Mgmt then the Dante primary IP address will be associated with a network connection that has been made

to either the Dante primary or Dante secondary RJ45 jack on the Model 5422A's back panel. If the network configuration is selected for Redundant or Redundant+Mgmt then the Dante primary IP address will be associated with the RJ45 jack labeled PRI on the Model 5422A's back panel.

Whenever the IP address configuration is selected for Manual the manual Dante primary IP address can be modified as desired. This will be indicated by an arrow icon that will show in the upper-right corner of the display. To start the process of changing the Dante primary IP address press the Enter pushbutton switch on the front panel. An icon with a wrench and screwdriver will display to indicate that an edit is in process. Use the left and right arrow pushbutton switches to select which specific digit of the IP address number is to be modified. Press the up and down arrow pushbuttons to select the desired number. The standard dot-decimal notation is used to display and revise the Dante primary IP address. Once all the desired changes have been made press the Enter button to store them.

To cause the Model 5422A to use the new Dante primary IP address setting requires that the unit's Dante interface be rebooted (restarted). This can be performed using the reboot Dante front-panel menu page. Rebooting the entire the Model 5422A can also be utilized to cause a new Dante primary IP address to be used. This can be accomplished using the reboot device menu page, using a function on one of the management webpages, or by power cycling the Model 5422A. Restoring the Model 5422A to its default values will not change a stored Dante primary IP address.

**Dante Primary Subnet Mask:** This menu page shows the stored subnet mask value associated with the Dante primary interface. (This value has nothing to do with the subnet mask values utilized by the Dante secondary or management ports.) When the IP address configuration has been selected for Automatic this field cannot be changed and a lock icon will show in the upper-right corner of the display. This value will be utilized only when the manual mode has been selected for the Dante primary IP address configuration.

Whenever the IP address configuration is selected for Manual the subnet mask value can be modified as desired. This will be indicated by an arrow icon that will show in the upper-right corner of the display. To start the process of changing the subnet mask value press the Enter pushbutton switch on the front panel. An icon with a wrench and screwdriver will display to indicate that an edit is in process. Use the up and down arrow pushbutton switches to select the desired subnet mask value. Once the desired value has been selected press the Enter button to store it.

To instruct the Model 5422A to use the new Dante subnet mask value requires that the unit's Dante interface be

rebooted (restarted). This can be performed using the reboot Dante front-panel menu page. Rebooting the entire Model 5422A can also be utilized to cause a new Dante primary subnet mask value to be used. This can be accomplished using the reboot device menu page, using a function on one of the management webpages, or by power cycling the Model 5422A. Restoring the Model 5422A to its default values will not change a stored Dante primary subnet mask value.

**Ethernet Switch Configuration:** This menu page shows the Model 5422A's network configuration as determined by a setting in the Dante Controller application. The term "switch" refers to an Ethernet switching and routing integrated circuit that is part of the Model 5422A's hardware. How this integrated circuit is configured determines the how the Model 5422A's three Ethernet ports will function. This menu page will show Switched, Redundant, Switched+Mgmt, or Redundant+Mgmt. It will also display Error in the unlikely event that an error has occurred in the Brooklyn II module that supports the Model 5422A's Dante interface.

**Reboot Dante:** This menu page allows the Dante interface to be rebooted (restarted). This can be useful to force the Model 5422A's Dante interface to utilize revised Dante primary IP address and related parameters. It can also be useful when troubleshooting a Dante network issue. An arrow icon will show in the upper-right corner of the reboot Dante menu. To start the process of rebooting (restarting) the Dante interface press the Enter pushbutton on the unit's front panel. This will lead to a confirmation page being displayed. Use the left and right arrow pushbutton switches to select (highlight) the desired action. The choices are to cancel or to confirm. Press the Enter pushbutton switch to select the highlighted action.

Note that if the Dante interface is rebooted it may take 20 to 60 seconds for the Model 5422A's operation to fully restore. During this time period the management Ethernet port will also disconnect and then reconnect.

### Row Three

Row three contains five menu pages. Four of the menu pages are display-only and provide information about the specific Model 5422A, including its serial number, version numbers of the firmware (embedded software) that are in use, and information about the Dante interface's firmware. A fifth menu page allows the unit to be rebooted (restarted).

**Product Name & Serial Number:** This menu page shows the name of the product (Model 5422A) and the hardware serial number. The name and serial number (along with the three MAC addresses associated with the Ethernet interfaces) are assigned at the factory and cannot be changed.

**Main Firmware Version:** This menu page shows the version number of the Model 5422A's main firmware. This firmware (embedded software) is used in the Model 5422A's microcontroller (MCU) integrated circuit and can be updated using a USB flash drive. Details regarding this process are provided in the Technical Notes section of this guide.

**FPGA Firmware Version:** This menu page shows the version number of the firmware (embedded software) used in the Model 5422A's field-programmable-gate-array (FPGA) integrated circuit. This firmware can be updated using a USB flash drive. Details about the update process are provided in the Technical Notes section of this guide.

**Dante Product Version:** This menu page shows the product version number associated with the Model 5422A's Dante interface. The Model 5422A's Dante interface is implemented using a Brooklyn II module supplied by Audinate. This version number is assigned by Studio Technologies as an identifier when a firmware file is released. (This firmware combines specific Model 5422A configuration information with the Audinate-developed Dante operating firmware.) The firmware for the Model 5422A's Dante interface can be updated by way of an Ethernet connection using the Dante Updater software application that's provided as part of the Dante Controller software application.

**Reboot Device:** This menu page allows the Model 5422A to be rebooted (restarted). This can be useful to force the Model 5422A to utilize configuration changes made to the management and Dante interfaces. Rebooting (restarting) the Model 5422A will also cause the unit's Dante interface to reboot. An arrow icon shows in the upper-right corner of this menu. To start the process of rebooting the Model 5422A press the Enter pushbutton on the unit's front panel. This will lead to a confirmation page being displayed. Use the left and right arrow pushbutton switches to select (highlight) the desired action. The choices are to cancel or to confirm. Press the Enter pushbutton switch to select the highlighted action. The Model 5422A will then immediately commence the selected action.

After performing a system reboot (restart), 20 to 60 seconds may be required for the Model 5422A's operation to fully restore. During this time period all the Ethernet connections, including the Dante and management ports, will briefly disconnect and then reconnect.

### Screen Saver

A "screen saver" mode will automatically activate two minutes after the last press of any of the five front-panel pushbutton switches. When active, the screen saver mode will cause a continuous sequence of three menu pages to show. The display sequence is continuous with each



menu page advancing after four seconds to display the next one.

When the screen saver mode is active pressing the Enter pushbutton switch on the front panel will cause it to stop and immediately display item one of row one, the current management IP address. To cause the screen saver mode to immediately start simultaneously press the left and right arrow pushbutton switches on the front panel.

The three menu pages in the Model 5422A's screen saver mode are:

1. The Studio Technologies' company logo graphic.
2. The product name (Model 5422A) and the Dante device name.
3. The current management IP address.

Details regarding the information provided in the screen saver menu pages were documented in previous sections of this guide.

## Technical Notes

### Dante IP Addresses

If the Model 5422A's Dante interface has been configured in the Dante Controller application for Switched or Switched+Mgmt operation, by default the Model 5422A's Dante primary Ethernet interfaces will attempt to automatically obtain an IP address and associated settings using DHCP (Dynamic Host Configuration Protocol). If a DHCP server is not detected then an IP address will automatically be assigned using the link-local protocol. This protocol is known in the Microsoft® world as Automatic Private IP Addressing (APIPA). It is also sometimes referred to as auto-IP (PIPPA). Link-local will randomly assign a unique IP address in the IPv4 range of 169.254.0.1 to 169.254.255.254. In this way, multiple Dante-enabled devices will connect together and automatically function, whether or not a DHCP server is active on the LAN. Even two Dante-enabled devices that are directly interconnected using an RJ45 patch cord should correctly acquire IP addresses and be able to communicate with each other. As previously discussed in this guide, using Dante Controller the Model 5422A's Dante Ethernet IP address(es) and related network parameters can also be set for manual (fixed or static) operation.

If the Model 5422A's Dante interface has been configured in Dante Controller for Redundant or Redundant+Mgmt operation then both the Model 5422A's Dante primary and Dante secondary Ethernet interfaces will attempt to automatically obtain IP addresses and associated network settings using DHCP. If DHCP is not available then link-local IP addresses will be assigned. If automatic assignment of IP

addresses is not desired each interface can be individually configured using Dante Controller to use a manual (fixed or static) IP address and related network parameters.

The specific IP address assigned to each of the Model 5422A's Dante interfaces can be identified using several methods. The Dante Controller application will directly display the network parameters of the primary and, if utilized, secondary Ethernet interfaces. Another means is to utilize the Model 5422A's network configuration webpage to directly display the IP addresses assigned to the primary and, if utilized, secondary Ethernet ports. The Model 5422A's front-panel menu system can also be selected to display the Dante primary IP address.

### Optimizing Dante Network Performance

For best Dante audio-over-IP performance a network that supports VoIP QoS (voice-over-internet-protocol quality of service) capability is recommended. This can typically be implemented on virtually all contemporary managed Ethernet switches. There are even specialized switches that are optimized for entertainment-associated applications. Also, it's recommended that IGMP snooping functionality on Ethernet switch ports associated with Dante devices be disabled. This can be important, allowing Dante-related multicast data traffic, including PTPv1, to be correctly supported. Refer to the Audinate website ([audinate.com](http://audinate.com)) for details on how to optimize a network for Dante applications.

### Management IP Address and Configuration

It's easy to determine the active IP address being used by the Model 5422A's management Ethernet port. The most direct method is to simply watch the front-panel screens that are active in the "screen saver" mode. This mode will enable automatically two minutes after the last press of any of the front-panel buttons. The front-panel menu system also allows the management IP address to be displayed and, if required, revised. A menu structure diagram is available in Appendix C of this guide. It's also available as a separate document on the Studio Technologies website.

By default, the Model 5422A's management Ethernet interface address configuration is set for automatic. In this way, it will attempt to automatically obtain an IP address and associated settings using DHCP. If a DHCP server is not detected an IP address will automatically be assigned using the link-local protocol in the IPv4 range of 169.254.0.1 to 169.254.255.254. There are two ways that the management Ethernet IP address and related network parameters can be set to a manual (fixed or static) configuration. The first method uses the front-panel display and buttons to allow the management Ethernet network parameters to be viewed and revised as desired. An even easier method

might be to use the network configuration webpage that is provided as part of the Model 5422A's management webpages.

### Model 5422A Firmware Update Procedure

It's possible that updated versions of the two firmware (embedded software) files that are utilized by the Model 5422A's microcontroller (MCU) and field-programmable-gate-array (FPGA) integrated circuits will be released to add features or correct issues. Refer to the Studio Technologies' website for the latest firmware files. They are called the Main and FPGA firmware files. The Model 5422A has the ability to load applicable firmware files into non-volatile memory by way of a standard USB flash drive. The Model 5422A implements a USB host function and provides access by way of a type A receptacle located on the unit's back panel. The Model 5422A updates its firmware using two files. The Main firmware is named **M5422A.bin** and the FPGA firmware is named **DIAE.bit**.

The update process begins by preparing a USB flash drive. The flash drive doesn't have to be empty (blank) but must be in the personal-computer-standard FAT32 format. Either or both of the firmware files can be automatically loaded at essentially the same time. On the flash drive's root folder, save the desired new firmware files, ensuring that the required names are specified. The file name for the Main firmware must be **M5422A.bin**. The file name for the FPGA firmware must be **DIAE.bit**. Be certain to use the eject command to ensure that each file is correctly stored on the USB flash drive.

Studio Technologies will supply each firmware file inside a .zip archive file. While the firmware file inside of the zip file will adhere to the naming convention required by the Model 5422A, the name of the zip file itself will include the file's version number. For example, a zip file named **M5422Av1r00MCU.zip** would indicate that version 1.00 of the Main firmware (**M5422A.bin**) is contained within this zip file.

Once the prepared USB flash drive is inserted into the USB jack, located on the Model 5422A's back panel, the Model 5422A must be powered off and then powered on again. At this point the file(s) stored on the USB flash drive will automatically load. The precise steps required will be highlighted in the following paragraphs.

To install either or both of the firmware files follow these steps:

1. Remove power from the Model 5422A. This will entail removing the AC mains power connector or removing the connector associated with the external source of nominal 12 volts DC. (Both must be disconnected if dual powering has been implemented.)

2. Locate the USB jack on the Model 5422A's back panel. It is labeled Firmware Update. Directly adjacent to the USB jack is a small hole that provides visual access to a green LED indicator.
3. Insert the prepared USB flash drive into the USB jack.
4. Apply power to the Model 5422A. Power can be provided by connecting AC mains or a source of nominal 12 volts DC.
5. After a few seconds the Model 5422A will run a "boot loader" program that will automatically load and save the new firmware file(s) that are present on the USB flash drive. The update process can range from approximately 10 seconds to approximately 60 seconds, depending on which of the files are going to be updated. While files are being loaded the green LED, located adjacent to the USB jack, will flash slowly. Once the loading process has completed the Model 5422A will reboot (restart) using the newly saved firmware.
6. At this time the Model 5422A is functioning with the newly loaded firmware and the USB flash drive can be removed.
7. It's a good idea to confirm that the desired Model 5422A's Main and FPGA firmware versions are loaded and operating as expected. There are two methods for observing the Model 5422A's firmware version numbers. The most direct is to use the front-panel display. Alternately, the System webpage from the management webpages can be utilized.

Note that no harm will occur if power is applied to the Model 5422A that has a USB flash drive connected that doesn't have relevant files in its root folder. Upon power up the green LED, located adjacent to the USB jack, will flash on and off rapidly for a few seconds to indicate that a valid file has not been found. After this warning, normal operation using the unit's existing firmware will begin.

### Dante Firmware Update

As previously discussed in this guide, the Model 5422A implements Dante connectivity using the Brooklyn II module from Audinate. The Dante Controller software application can be used to determine the version of the firmware (embedded software) that resides in the Brooklyn II module. The System webpage provided by the Model 5422A's management web server can also be used to identify the firmware version.

The firmware (embedded software) residing in the Brooklyn II module can be updated using the Model 5422A's Dante primary Ethernet port. Performing the update process is easily accomplished using an automated method called Dante Updater that's included as part of the Dante

Controller software application. The Dante Controller application is available, free of charge, from the Audinate website ([audinate.com](http://audinate.com)).

The latest Model 5422A firmware file, with an extension of .dnt, is available on the Studio Technologies' website as well being part of Audinate's product library database. The latter allows the Dante Updater software application that is included with Dante Controller to automatically query and, if required, update the Model 5422A's Dante interface.

### **Restoring Model 5422A's Default Configuration Values**

A command in the System Information webpage provided by the Model 5422A's management web server allows most of the configuration settings to be restored to their default configuration values. This can be useful but must be used with caution. Any customization made to the Model 5422A's configuration will be lost. This can be offset in a positive way by returning the Model 5422A to a known configuration, a point that might aid in troubleshooting an issue. Refer to Appendix D for a list of the default values.

### **Lost User Name and/or Password**

As is covered in detail in other sections of this guide, gaining access to the Model 5422A's configuration menu webpages requires entering the correct user name and password. If the default entries, both of which are **guest**, are stored for use then they will display on the Login menu webpage. Pressing the Log In button on that webpage will then access the Main configuration webpage. If either or both the user name and the password have been configured to be something other than **guest** (the default) then nothing will show in the fields associated with the login menu webpage.

If knowledge of the stored user name and/or password is "lost" then the Model 5422A includes a "back door" to allow access. But as a security measure physical access to the unit is required to utilize that access method; there is no means to access the unit via an Ethernet port without knowledge of the user name and password. The exact process of accessing the Model 5422A's configuration webpages without knowledge of the user name and/or password is detailed in Appendix E, located at the end of this guide.

### **Creating a Party-Line of more than 32 Channels**

A Model 5422A has a maximum group size of 32 channels. (In this case, the one group would be using all 32 channels of an audio engine.) So, in theory, a 32-channel group configured for the Party-Line operating mode would allow a maximum of 32 users to be part of that party-line (PL) circuit or channel. In the vast majority of applications that should be sufficient; having anything close to 32 users on the same

PL would be an exception. But exceptions do occur and it's possible that a special application would require more than 32 users to be part of the same party-line. That can easily be accomplished using a Model 5422A-02 which provides two 32-channel audio engines. Two groups from separate audio engines can be linked together using just one pair of Dante audio channels from each group.

The maximum number of users associated with a single party-line (PL) that a Model 5422A-02 can create is 62. To accomplish this is simple. Both audio engines in the same Model 5422A-02 would be configured to have 32 channels per group. And both groups would be configured for the Party-Line operating mode. Then two audio channels would be routed (Dante subscribed) in a "crisscross" fashion, linking the two groups. The specific channels used to link the two groups isn't important. However, a pair of channels from each group must be used.

For simplicity, we'll describe how to use the last channel pair in each group for the group interconnection. Start by routing (Dante subscribing) output 32 in the group created by the first audio engine to input 32 in the group created by the second audio engine. Then route (Dante subscribe) output 32 of the group created by the second audio engine to input 32 on the group created by the first audio engine. That's it! Now any user can be connected to any of the 31 available input/output pairs in either group. This means that there is a total of 62 channels (two groups, each with 31 channels) available for users to join. The audio performance should be excellent although one hopes that only a few people will be speaking at the same time! The same concept should work when interconnecting groups in multiple Model 5422A units. In theory, 122 users could share a party-line (PL) circuit or channel when two Model 5422A-02s are configured appropriately.

Note that when linking groups, selecting the Party-Line w/Auto Mix operating mode is not recommended. The Auto Mix logic would not function properly between the multiple groups. Users within the same groups would experience excellent audio quality but not so between groups.

## Specifications

### Applications:

Designed to create multiple party-line (PL) circuits in Dante audio-over-IP environments. Also provides functions for use in Remote Integration (REMI) and At-Home production applications. This includes summing (mixing) of audio channels, IFB (talent cueing) creation, and audio switching functions for general-purpose applications. Special Dante pass-thru mode allows flow-limited and non-AES67-compliant Dante devices to participate in more-advanced applications. Auto Mix capability can be selected for use in party-line and summing operating modes.

### Versions Available:

**Model 5422A-01:** one 32-channel audio engine

**Model 5422A-02:** two 32-channel audio engines (64 channels total)

### Audio Engine Configuration Options:

**Group Size:** the following group sizes can be selected for each 32-channel audio engine:

- 32 (one group)
- 24, 8 (two groups)
- 20, 8, 4 (three groups)
- 16, 16 (two groups)
- 16, 12, 4 (three groups)
- 12, 12, 4, 4 (four groups)
- 8, 8, 8, 8 (four groups)
- 8, 8, 8, 4, 4 (five groups)
- 8, 8, 4, 4, 4, 4 (six groups)
- 4, 4, 4, 4, 4, 4, 4, 4 (eight groups)

**Group Modes:** Party-Line w/Auto Mix, Party-Line, Summing Bus w/Auto Mix, Summing Bus, Pass-Thru, IFB, and Audio Switching, selectable by individual group

**Receiver (Input) and Transmitter (Output) Channel**

**Level Adjustment:**  $\pm 20$  dB, selectable in 1-dB steps

### Audio Performance:

**Internal Digital Audio Processing:** 32-bit, fixed

**Input-to-Output Audio Processing Latency:**

<100  $\mu$ Sec

**Auto Mix:** sophisticated FPGA-based algorithm provides enhanced audio intelligibility for party-line (PL) and summing bus applications

### IFB (Talent Cueing) Support:

**Voice Detect Operation (VOX):**

- Audio Bandpass: 185 to 1300 Hz,  $-3$  dB
- Level Threshold:  $-44$  dBFS at 400 Hz
- Minimum On Time: 385 mSec

### **Tone Detect Operation (TOX):**

- Level Threshold:  $-23$  dBFS at 16 kHz;  $-28$  dBFS at 18 kHz;  $-30$  dBFS at 20 kHz
- Minimum On Time: 80 milliseconds

### **Interrupt Audio-to-IFB Output Low-Pass Filter:**

$-6$  dB at 10 kHz;  $-28$  dB at 16 kHz;  $-55$  dB at 20 kHz

### **Interrupt Tone-to-IFB Output Rejection Filter:**

$-31$  dB at 18 kHz;  $-46$  dB at 20 kHz;  $-70$  dB at 22 kHz

**Program Audio Attenuation:** 0, 10, 15, 20 dB, full mute, configurable

### Audio Switching Support:

**Tone Detect Operation (TOX):**

- Level Threshold:  $-23$  dBFS at 16 kHz;  $-28$  dBFS at 18 kHz;  $-30$  dBFS at 20 kHz
- Minimum On Time: 80 milliseconds

### Network Audio Technology:

**Type:** Dante audio-over-IP

**AES67-2018 Support:** yes

**Dante Domain Manager™ (DDM) Support:** yes

**Ethernet Interface Configuration:** Switched, Redundant, Switched+Mgmt, or Redundant+Mgmt, selectable

**Clock Source:** Dante network or internal (can serve as basic Leader Clock)

**Bit Depth:** up to 32

**Encoding:** PCM 16, PCM 24, or PCM 32

**Sample Rate:** 48 kHz

**Number of Dante Receiver (Input) Channels:**

32 (Model 5422A-01), 64 (Model 5422A-02)

**Number of Dante Transmitter (Output) Channels:**

32 (Model 5422A-01), 64 (Model 5422A-02)

**Number of Dante Flows:** 32 transmitter, 32 receiver

**Internal Digital Audio Processing:** 32-bit, fixed

**Input-to-Output Audio Processing Latency:**

<100  $\mu$ Sec

**Network Interfaces:** 3, Primary, Secondary, and Management

**Type:** 1000BASE-T, Gigabit (GigE) twisted-pair Ethernet per IEEE 802.3ab (100 Mb/s supported but not recommended for optimal performance; 10 Mb/s not supported)

**Auto MDI/MDI-X Support:** yes

**Connection (NIC) Status LEDs:** one link and one activity for each Ethernet interface

**Software Updating:** USB flash drive supports updating of Main and FPGA firmware (embedded software); Dante interface updated via Ethernet interface

**Power Sources:**

**AC Mains:** 100 to 240 V, 50/60 Hz, 5 W maximum

**DC:** 10 to 18 V, 0.5 A max

**Connectors:**

**Ethernet:** 3, RJ45 jack

**USB:** type A receptacle (used only for updating firmware)

**DC Input:** 4-pin male XLR (pin 1 negative, pin 4 positive)

**AC Mains Input:** 3-blade, IEC 320 C14-compatible  
(mates with C13)

**Environmental:**

**Operating Temperature:** 0 to 50 degrees C (32 to 122 degrees F)

**Storage Temperature:** -40 to 70 degrees C (-40 to 158 degrees F)

**Humidity:** 0 to 95%, non-condensing

**Altitude:** not characterized

**Dimensions (Overall):**

19.00 inches wide (48.3 cm)

1.72 inches high (4.4 cm)

7.9 inches deep (20.1 cm)

**Mounting:** one space (1U) in a standard 19-inch rack

**Weight:** 2.8 pounds (1.3 kg)

Specifications and information contained in this User Guide subject to change without notice.

## Appendix A–Network Configuration Examples

### ONE LAN – SWITCHED DANTE

MODEL 5422A NETWORK INTERFACE  
CONFIGURED FOR SWITCHED OPERATION

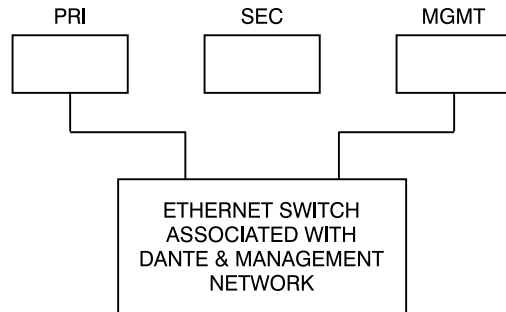

### ONE LAN – SWITCHED DANTE

MODEL 5422A NETWORK INTERFACE  
CONFIGURED FOR SWITCHED OPERATION

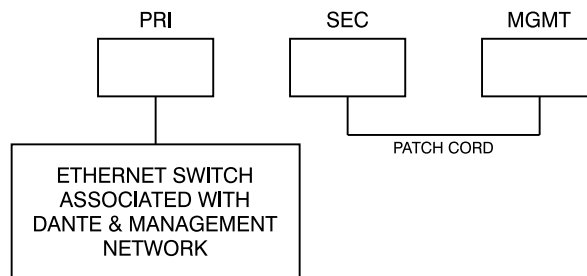

### TWO LANs – SWITCHED DANTE

MODEL 5422A NETWORK INTERFACE  
CONFIGURED FOR SWITCHED OPERATION

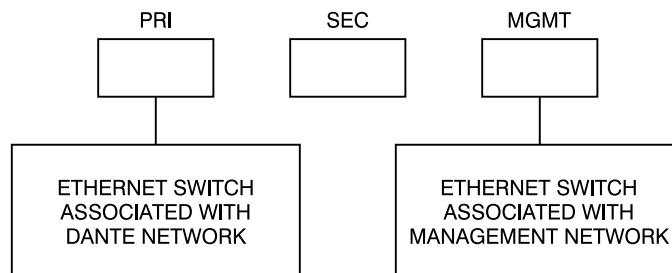

**TWO LANs – REDUNDANT DANTE**  
MODEL 5422A NETWORK INTERFACE  
CONFIGURED FOR REDUNDANT OPERATION

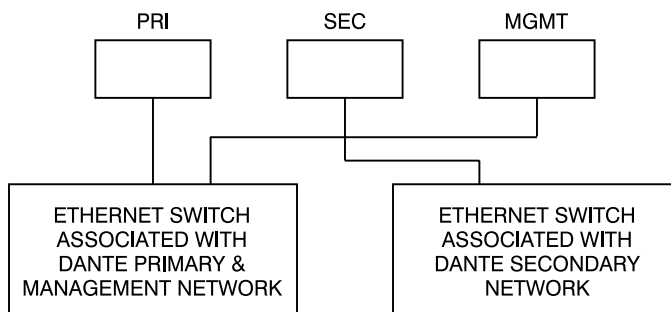

**TWO LANs – REDUNDANT DANTE**  
MODEL 5422A NETWORK INTERFACE  
CONFIGURED FOR REDUNDANT OPERATION

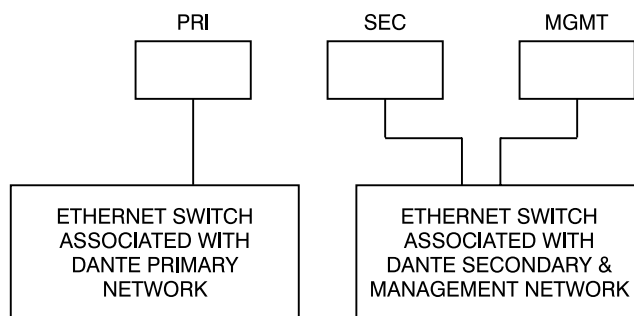

**THREE LANs – REDUNDANT DANTE**  
MODEL 5422A NETWORK INTERFACE  
CONFIGURED FOR REDUNDANT OPERATION

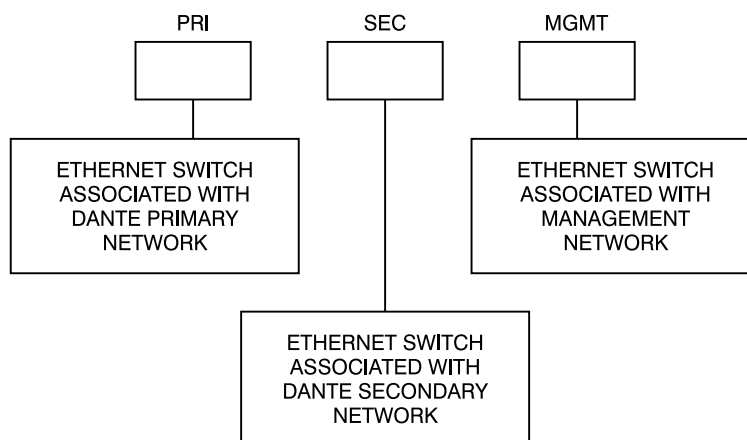

**ONE LAN – SWITCHED+MANAGEMENT DANTE**

MODEL 5422A NETWORK INTERFACE  
CONFIGURED FOR SWITCHED+MGMT OPERATION

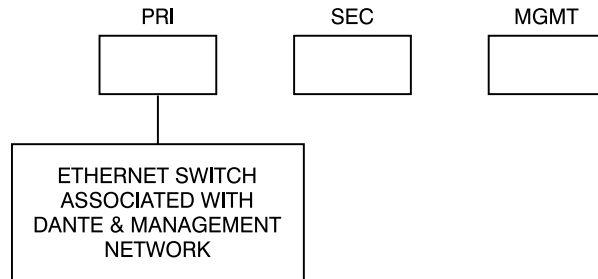

**TWO LANs – REDUNDANT+MANAGEMENT DANTE**

MODEL 5422A NETWORK INTERFACE  
CONFIGURED FOR REDUNDANT+MGMT OPERATION

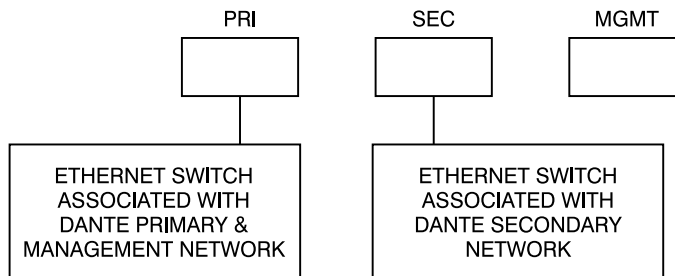



## **Appendix B–Dante Controller Network Default Configuration Values**

### **Dante Interface Default Values:**

Device Config, Sample Rate: 48 k

Device Config, Pull-up/down: Not Supported

Device Config, Preferred Encoding: PCM 24

Device Config, Clocking, Unicast Delay Requests: Disabled

Device Config, Device Latency: Latency: 1.0 msec

Network Config, Switch Configuration, Current: Switched+Mgmt

Network Config, Addresses: Obtain an IP Address Automatically (default)

AES67 Config, AES67 Mode, Current: Disabled

## Appendix C–Front-Panel Menu Structure

### Model 5422A Front-Panel Menu Structure

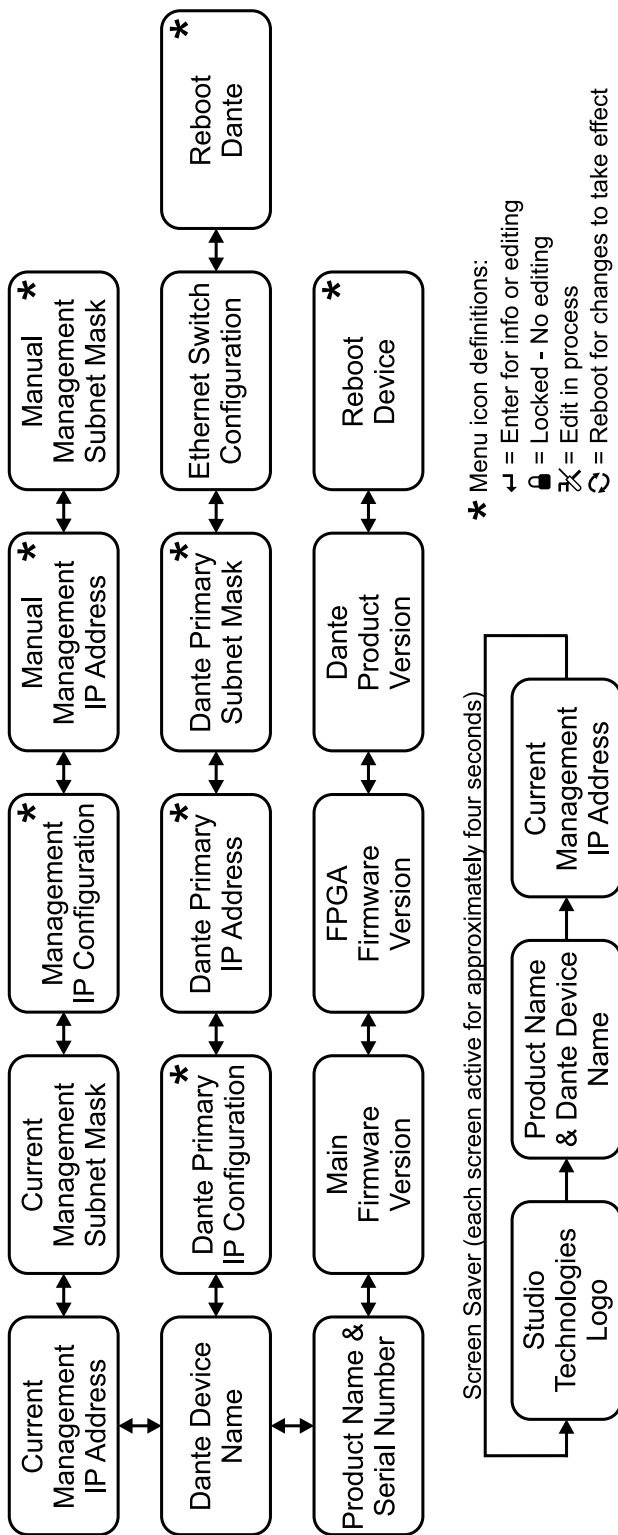

1. Screen saver automatically activates two minutes after last button press.
2. Press left and right buttons simultaneously to immediately enter screen saver mode.
3. Pressing Enter while screen saver is active goes directly to Current Management IP Address page.

## Appendix D—Model 5422A Default Configuration Values

### Audio Engine 1 Menu

Channels per Group: 8, 8, 8, 8

#### Group Configuration (typical for all four Groups)

Group A:

Group A Label: Group A

Operating Mode: Party-Line w/Auto Mix

IFB Detection Mode: Voice-Operated (VOX)

IFB Dim Level: 15 dB

#### Channel Configuration (typical for all 32 Channels)

Channel Label (Tx/Rx): ChX (where X = Channel number)

Receiver (Input) Gain ( $\pm$  dB): 0

Transmitter (Output) Gain ( $\pm$  dB): 0

### Audio Engine 2 Menu (for Model 5422-02 only)

Channels per Group: 8, 8, 8, 8

#### Group Configuration (typical for all four Groups)

Group J:

Group A Label: Group J

Operating Mode: Party-Line w/Auto Mix

IFB Detection Mode: Voice-Operated (VOX)

IFB Dim Level: 15 dB

#### Channel Configuration (typical for all 32 Channels)

Channel Label (Tx/Rx): ChX (where X = Channel number)

Receiver (Input) Gain ( $\pm$  dB): 0

Transmitter (Output) Gain ( $\pm$  dB): 0

### Network Menu, Management Interface

IP Address Configuration: Automatic

Manual IP Address: 192.168.1.22

Manual Subnet Mask: 255.255.255.0

Manual Gateway: 192.168.1.1

(Note: Using the Restore Default Settings command in the System menu does not restore these items to their default configuration values.)

### Access Menu, Management Login Credentials

User Name: guest

Password: guest

(Note: Using the Restore Default Settings command in the System menu does not restore these items to their default configuration values.)

## Appendix E—Accessing the Unit when User Name and/or Password Not Known

Follow this procedure to access the Configuration menu webpages if the user name and/or password is not known.



1. Remove power from the Model 5422A.
2. Press and hold the left arrow and Enter buttons.
3. While continuing to hold the two buttons apply AC Mains or 12 volts DC power.
4. Continue to hold the two buttons and allow the Model 5422A to start. The Status LEDs on the front panel will first light green then light red in their start-up sequence.
5. Once the Status LEDs have completed their start-up sequence release the two buttons.
6. Use a web browser to access the Model 5422A's Configuration menu webpages. The management port's IP address to use is shown in the current management IP address page on the front-panel display. Pressing the Enter button will cause the current management IP address page to immediately show on the front-panel display.
7. From the Home webpage select the Login webpage tab. Leave the user name and password fields empty and click the Log In button. This will allow access to the Configuration menu selections. At this point your web browser should display the Model 5422A's Home webpage.
8. Navigate to the Access menu. From this webpage you will be able to view the stored user name. You will not be able to view the previously saved password. Enter and confirm a new password. Henceforth, to access the Model 5422A's Configuration menu will require the use of the stored user name and password.

