

DXD-16

Universal Clock

Operations manual

Version 2.10
January 2021

All materials herein © Brainstorm Electronics, Inc.

Brainstorm Electronics reserves the right to change or modify the contents of this manual at any time.

Table of Content

1. Introduction.....	6
2. Installation.....	7
2.1 UNPACKING	7
2.2 INSTALLING THE DXD-16	7
3. Quick Start	7
4. I/O's Description and Cable Requirements	8
4.1 AC POWER.....	8
4.2 ANTENNA (OPTION)	8
4.3 GPIO / TC OUT / 1PPS I/O / RS-232	8
4.4 HD/SDI (option)	8
4.5 ETHERNET PORTS	8
4.6 REFERENCE INPUTS & TERMINATION SWITCHES	8
4.7 UNIVERSAL OUTPUTS.....	8
4.8 DC POWER	8
5. Front Panel Display & LED's	9
5.1 FRONT PANEL DISPLAY.....	9
5.2 FRONT PANEL LED'S	9
6. Display	10
6.1 Main Rotation.....	10
6.1.1 MAIN ROTATION PAGES LAYOUT	10
6.1.2 MAIN ROTATION PAGES	10
6.2 Status Mode	11
6.2.1 STATUS INFORMATION PAGES LAYOUT.....	11
6.2.2 STATUS INFORMATION PAGES.....	11
6.3 Set Up Mode.....	12
6.3.1 MENU LEVELS.....	12
6.3.2 NAVIGATION	12
6.3.3 ENTER KEY	12
6.3.4 STATUS VALUES.....	12
6.3.5 MENU GROUPS	13
7. Menu Description	14
7.1 Reference.....	14
7.1.1 REFERENCE (MENU 1.1)	14
7.1.2 SYNC PARAMETERS (MENU 1.2)	15
7.2 BNC Inputs	15
7.2.1 BNC INPUT A SET UP (MENU 2.1)	15
7.2.2 BNC INPUT B SET UP (MENU 2.2)	15
7.3 BNC Outputs	15
7.3.1 BNC OUTPUTS 1-4 (MENU 3.1)	15
7.3.2 BNC OUTPUTS 5-8 (MENU 3.2).....	16

7.3.3 BNC OUTPUTS 9&10 MENU (3.3)	16
7.3.4 BNC OUTPUTS 11&12 (MENU 3.4)	16
7.3.5 BNC OUTPUTS 13&14 (MENU 3.5)	16
7.3.6 BNC OUTPUTS 15&16 (MENU 3.6)	16
7.3.7 AUDIO BASE RATE A (MENU 3.7)	16
7.3.8 AUDIO BASE RATE B (MENU 3.8)	16
7.3.9 MUTE ON UNLOCK (MENU 3.9)	16
7.3.10 DELAY/ADVANCE 1 - 4 (MENU 3.10)	17
7.3.11 DELAY/ADVANCE 5 - 8 (MENU 3.11)	17
7.3.12 DELAY/ADVANCE 9 & 10 (MENU 3.12)	17
7.3.13 DELAY/ADVANCE 11 & 12 (MENU 3.13)	17
7.3.14 DELAY/ADVANCE 13 & 14 (MENU 3.14)	17
7.3.15 DELAY/ADVANCE 15 & 16 (MENU 3.15)	17
7.4 Network	18
7.4.1 NET 1 (MENU 4.1)	18
7.4.1.1 NET 1 IP ADDRESS (MENU 4.1.1)	18
7.4.2 NET 2 (MENU 4.2)	18
7.4.2.1 NET 2 IP ADDRESS (MENU 4.2.1)	18
7.4.3 NET 3 (MENU 4.3)	18
7.4.3.1 NET 3 IP ADDRESS (MENU 4.3.1)	18
7.4.4 NET 4 (MENU 4.4)	18
7.4.4.1 NET 4 IP ADDRESS (MENU 4.4.1)	18
7.5 PTP	18
7.5.1 PORTS MODES (MENU 5.1)	18
7.5.2 GRANDMASTER [GROUP] (MENU 5.2)	19
7.5.3 PORT 1 (MENU 5.3)	19
7.5.3.1 Port 1 Controls (Menu 5.3.1)	19
7.5.3.2 Port 1 Timing (Menu 5.3.2)	19
7.5.3.3 Port 1 Independent Master (Menu 5.3.3)	20
7.5.3.4 Port 1 Time Jam (Menu 5.3.4)	20
7.5.4 PORT 2 (MENU 5.4)	20
7.5.5 PORT 3 (MENU 5.5)	20
7.5.6 PORT 4 (MENU 5.6)	20
7.6 GPS	20
7.7 Time	20
7.7.1 TIME STANDARDS (MENU 7.1)	20
7.7.2 REAL TIME CLOCK (MENU 7.2)	21
7.7.3 TIME & DATE DISPLAY (MENU 7.3)	21
7.7.4 LEAP SECONDS (MENU 7.4)	21
7.8 Time Code	22
7.8.1 SMPTE 2059 SETUP (MENU 8.1)	22
7.8.2 LTC GENERATOR 1 & 2 (MENUs 8.2 & 8.3)	22
7.9 GPIO	22
7.9.1 GPIO INPUTS (MENU 9.1)	22
7.9.2 GPIO OUTPUTS (MENU 9.2)	22

7.10 Presets	23
7.11 Utility	23
7.11.1 BRIGHTNESS (MENU 11.1)	23
7.11.2 FRONT PANEL LOCKOUT (MENU 11.2)	23
7.11.3 CLEAR MEMORY (MENU 11.3)	23
7.11.4 REBOOT (MENU 11.4)	23
7.11.5 FEATURE KEYS (MENU 11.5)	23
8. Time of Day	24
8.1 RTC (Real Time Clock)	24
8.2 Time Jam	25
8.2.1 TIME JAM TO PTP	25
8.2.1.1 What is the sequence of a complete Time Jam to PTP?	25
8.2.1.2 What is required for a Time Jam to PTP?	25
8.2.2 OTHER TIME SOURCES - GPS	25
8.2.3 DISPLAY & PORT STATES	25
8.2.4 COLOR FRAME AND TIME JAM	26
8.2.3 PRACTICAL APPLICATIONS OF TIME JAM	26
9. Input rate: Learn vs. Set	26
9.1 BNC INPUT SET UP MENU	26
9.2 ABOUT USING THE 'SET' MODE FOR THE REFERENCE SOURCE	27
9.3 OFFSPEED REFERENCE	27
10. External Reference Failover (BNC)	27
10.1 REFERENCE FAILURE WITH AN ALTERNATE REFERENCE	27
10.2 REFERENCE FAILURE WITH NO ALTERNATE REFERENCE	28
11. Lock Status	28
11.1 LOCK STATUS & PTP	28
12. PTP Port States	29
13. Output Deviation Indication:	29
14. Positional change from an External PTP Grandmaster	30
14.1 JUMP TO RELOCK	30
15. General Information on PTP	31
15.1 TIME AND PHASE	31
15.2 WHAT IS PTP?	31
15.3 A/V OVER IP APPLICATIONS	31
15.4 PTP DESCRIPTION	31
15.5 SELECTING A GRANDMASTER	32
15.6 SYNCHRONIZATION	32
15.7 DELAY MEASUREMENT MECHANISM	33
15.8 TYPES OF CLOCKS	33
15.9 PTP DOMAINS	33
15.10 PTP PROFILES	33
15.11 EPOCH	33
16. Typical PTP Set-Ups	34

16.1 BOUNDARY CLOCK	34
16.2 4-MASTER PORTS ON A SINGLE DOMAIN WITH GPS REFERENCE.....	35
16.3 4-MASTER PORTS ON SEPARATE DOMAINS WITH GPS REFERENCE.....	35
16.4 HYBRID SYNC GENERATOR ACCEPTING MULTIPLE REFERENCES	36
16.5 PTP PRIMARY AND SECONDARY NETWORKS	36
16.6 DISTRIBUTED PTP VS. INDIVIDUAL GRANDMASTERS WITH GNSS	37
17. Guidelines for configuring PTP (Precision Time Protocol)	38
17.1 REQUIREMENTS.....	38
17.2 RECOMMENDATIONS	38
17.3 NETWORKING HARDWARE	39
18. Firmware Updates	40
18.1 FIRMWARE LOADER PAGE	40
18.2 PROGRAMMING SEQUENCE	40
18.3 FIRMWARE FILE NAMING CONVENTION.....	40
18.4 UPLOADER	41
19. Remote Control	41
20. GPIO / LTC connector (DB-25)	42
20.1 GPIO.....	42
20.2 1PPS/GPO	42
20.3 LTC.....	42
21. Non-Volatile Storage	42
22. Power.....	42
22.1 POWER FAILURE W/ DUAL POWER SOURCES	42
23. Troubleshooting - Error / Warning Messages	43
23.1 RATE INVALID WARNING.....	43
23.2 PRIMARY AND ALTERNATE REFERENCES INCOMPATIBLE.....	43
23.3 OFFSPEED REFERENCE	43
23.4 PTP 'NO PORT' WARNING	43
23.5 PORT IN PASSIVE STATE	43
23.6 TIME JAM TIME OUT	44
23.7 ALL PTP PORTS ARE IN PASSIVE STATE.....	44
24. Appendix	45
24.1 APPENDIX A: VIDEO INPUT FORMATS.....	45
24.2 APPENDIX B: AUDIO BASE RATES.....	45
24.3 APPENDIX C: PULLED RATES	45
24.4 APPENDIX D: MULTIPLIER RATES	46
24.5 APPENDIX E: DB-25 PINOUT & GPIO CIRCUITRY	46
24.6 APPENDIX F: DIFFERENCES BETWEEN THE DXD-16 PTP CONNECTORS	48
24.7 APPENDIX G: FACTORY PRESETS	49
24.8 APPENDIX H: MENUS, MESSAGES & DISPLAY PAGES.....	50

1. Introduction

The DXD-16 Universal Clock is designed to be the central source of time in a modern A/V installation. It combines PTP, GPS and legacy sync signals such as Word Clock, AES and Video Sync, making it truly universal by keeping the traditional audio/video equipment and IP networks in perfect sync.

The DXD-16 has the capability of being a PTP slave or a PTP Grandmaster.

- As a PTP slave, the DXD-16 can generate legacy sync so that the legacy equipment locks to the network.
 - As a PTP master, the DXD-16 can lock to external sync sources such as WC, AES or video sync so that the network locks to the legacy equipment.
 - It can also act as a stand-alone master, locked to its internal oscillator (or optionally to GPS) providing sync to the network via the PTP ports and the legacy equipment via the Universal Outputs, simultaneously..
- On the PTP side, 4 independent Ethernet ports are included. Each port can be either a PTP Grandmaster, a PTP slave or part of boundary clock.
 - The precision multi-format reference generator provides up to 6 different legacy clocks simultaneously. The 16 universal outputs can be configured for any of the generated signals, giving the DXD-16 great flexibility.
 - The DXD-16 has a battery backed-up internal Real Time Clock 'RTC' that can generate TIME information when the selected reference does not have it, such as WC, AES or Video Sync.
 - An optional GPS receiver can be installed in the DXD-16 providing an extremely accurate timing source and enabling multiple DXD units in remote locations to be locked and in phase with one another. Additionally, with the DXD/GPS option, the DXD-16 locked to GPS has a higher priority for PTP Grandmaster status.

DXD-16 DIAGRAM

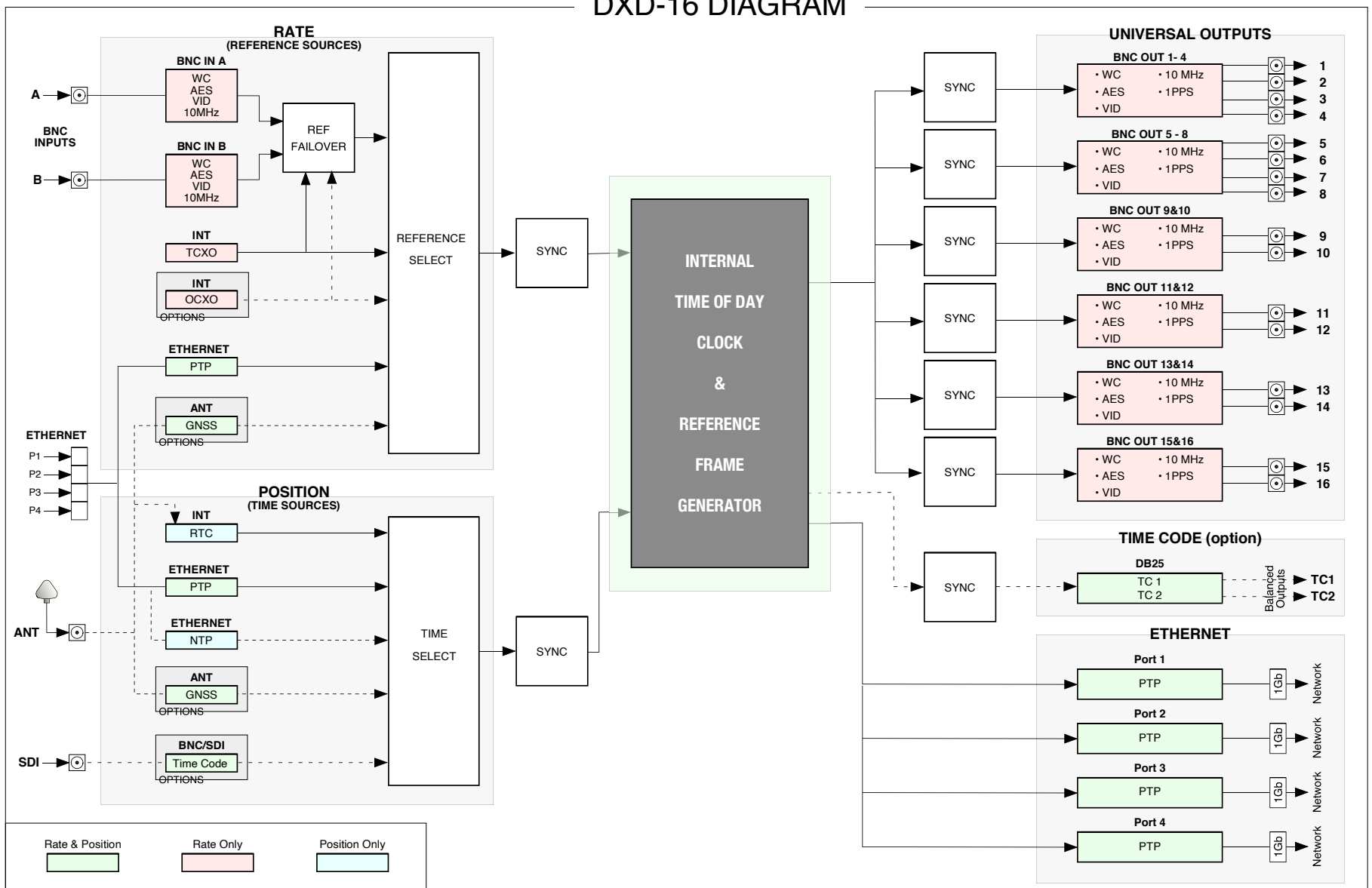

2. Installation

2.1 UNPACKING

When unpacking your DXD-16 the following items should be in the shipping carton:

- DXD-16 unit
- IEC power cable
- Registration card

2.2 INSTALLING THE DXD-16

The DXD-16 is designed to be mounted in a standard 19" rack. It requires 1U in height. Usual precautions should be respected when wiring the DXD-16: use high quality cables with good shield to guarantee a good signal transmission. Keep your cables as short as possible. The type of cables required are specified in chapter 4.

To preserve the integrity of the transmission line, it is recommended that you do not 'mult' a single output to multiple devices as it can degrade signal quality.

The BNC reference input needs to be properly terminated. If the DXD-16 is the last device in the chain, turn on the 75Ω termination switch on the rear panel. If you are looping through using a 'T' connector (again, not recommended), turn off the termination switch and make sure there is a 75Ω termination at the end of the chain.

3. Quick Start

You should read this manual to familiarize yourself with the DXD-16 features. The following simple steps are only provided to get you started right away.

Connect the supplied IEC power cable to the AC input connector (Power A) and plug it into a wall outlet. The DXD-16 will turn on automatically when power is connected. Power up takes approximately 50 seconds. After about 10 seconds, the display will light up showing the different steps and a progress bar.

Out of the box, the DXD-16 is set to generate NTSC video sync, referenced to its internal crystal. This signal is sent to all 16 outputs. The 4 PTP ports are in the DISABLED mode. DHCP is activated on each port so IP addresses will be provided automatically by the router.

To make changes, press the [SET UP] button and navigate to the required menu using the [UP] and [DOWN] buttons then pressing the [NAV ►] key.

- To change the reference, go to menu 1.
- To change the outputs, go to menu 3.
- To change the IP addresses, go to menu 4.
- To change the PTP ports settings go to menu 5.

Once you are in the right menu:

- use the [NAV ►] key to navigate to the right field;
- use the [UP] and [DOWN] keys to change the value;
- press the [ENTER] key to save the changes.

For more details on menu navigation, go to 6.3. For details on the different menus, go to chapter 7.

4. I/O's Description and Cable Requirements

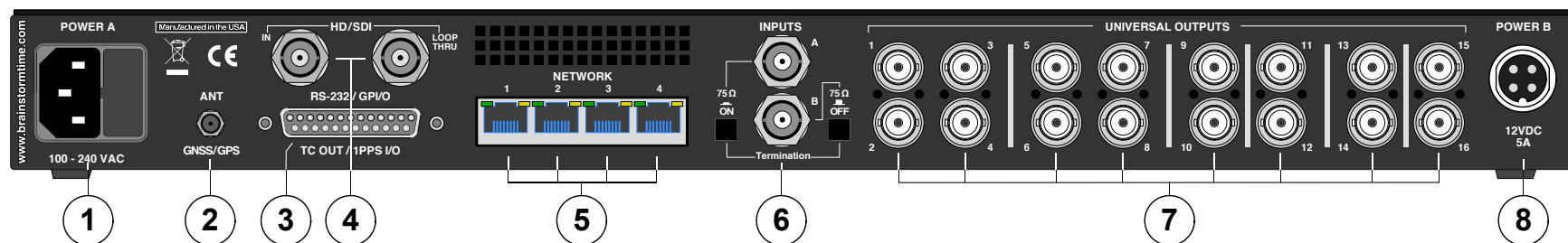

4.1 AC POWER

Universal power input, accepts 100 to 240 VAC.

Connector: IEC inlet - Fuse: 5A 125VAC 5X20MM

- Use an IEC power cable and connect to an 100/240 AC wall outlet.

4.2 ANTENNA (OPTION)

This port is used to connect a GNSS antenna to the optional DXD/GPS receiver.

Connector: SMA jack

- Use 50Ω coaxial cable with an SMA-Male to connect the GNSS antenna as specified in the DXD/GPS instructions manual.

4.3 GPIO / TC OUT / 1PPS I/O / RS-232

The 25pin connector is used for GPIO's, balanced TC outputs and 1 PPS output as well as future developments (reserved pins).

Connector: DB-25 female receptacle

- Use a custom DB-25 cable per the pin out described in appendix E

4.4 HD/SDI (option)

Connectors: BNC IN + BNC Loop Through

- Use standard 75Ω BNC coaxial cables (see DXD/SDI manual).

4.5 ETHERNET PORTS

4 independent Gb Ethernet ports used to connect the DXD-16 to a network for PTP sync or to control the unit remotely and upload firmware from any computer on the network. **Remote control and firmware update is from port #4 only.**

Connectors: RJ45 jack

- Use a standard cat6 Ethernet cable with RJ45 plugs.

4.6 REFERENCE INPUTS & TERMINATION SWITCHES

The 2 BNC inputs accept WC, AES, Video Sync and 10MHz based on the user selection (INPUTS Menu - see Appendix A for a list of supported HD & SD video formats). 10MHz is a sine wave typically 1/2 v, coming from a GPS receiver, a rubidium clock or other types of generators.

Connectors: BNC

- Use standard 75Ω BNC coaxial cables.

Each input has a 75Ω termination switch. Under normal conditions, it should be on. However, if a 'T' BNC is used to 'daisy-chain' the reference to another unit (not recommended), termination should be off on the DXD-16. The last unit in the chain, and only that unit, should have its termination on.

4.7 UNIVERSAL OUTPUTS

BNC outs 1-16 can output Word Clock, AES, 10MHz (1v pk-pk sine wave), HD Video Sync, or SD Video Sync, based on the user selection (BNC OUTPUTS menus).

Connector: BNC

- Use standard 75Ω BNC coaxial cables.

4.8 DC POWER

In addition to AC, the DXD-16 can also be powered by a 12VDC @ 48W source. Acceptable range is 11VDC to 17VDC.

For redundancy, the DC source can be connected together with the AC source.

To order a DC power supply (p/n PS-9), contact your dealer.

Connector: 4 pin circular connector

- Insert the 4 pin plug into the rear panel jack and secure by screwing the ring. Plug the supply into the wall using the standard IEC cable supplied.

5. Front Panel Display & LED's



5.1 FRONT PANEL DISPLAY

The DXD-16 front panel has a large full color display giving access to all the unit's parameters and settings.

In the normal operating mode, information is presented on the display in multiple pages referred to as the 'Main Rotation' (see chapter 6).

In addition to the normal operating mode, two additional modes exist that affect the display:

- SET UP Mode
- STATUS Mode

These two specialized modes are activated by pressing the corresponding button to the right of the navigation buttons. An LED lights up for each of these modes indicating activation.

In the STATUS mode, the displays shows additional status information organized on multiple pages, much like the Main Rotation pages (see chapter 6).

The SET UP mode is used to set the unit's parameters as described in 6.3.

Note that SET UP and STATUS modes are mutually exclusive. It means that, if you press the STATUS button while in the SET UP mode, you will exit the SET UP mode and enter the STATUS mode, and vice-versa.

5.2 FRONT PANEL LED'S

There are 12 status LED's to the right of the display insert area:

- IN A:..... a signal is present at the Input A connector;
- TERM OFF A:..... the rear panel termination switch is off (see 4.6);
- IN B: a signal is present at the Input B connector;
- TERM OFF B: the rear panel termination switch is off (see 4.6);
- GNSS/GPS: the option is installed, is running, and an antenna has been detected
- HD/SDI: a signal is present at the SDI input (optional)
- NETWORK 1: port 1 of the DXD-16 is connected to a network
- NETWORK 2: port 2 of the DXD-16 is connected to a network
- NETWORK 3: port 3 of the DXD-16 is connected to a network
- NETWORK 4: port 4 of the DXD-16 is connected to a network
- POWER A:..... AC Mains is connected to the Power A connector
- POWER B: 12VDC power is connected to the Power B connector

Note that, if one of the power LED's is flashing, it indicates that power was present at that connector but then disappeared, possibly due to a faulty power supply, and the other power source took over (see chapter 21 for more information).

6. Display

6.1 Main Rotation

In the standard operating mode, with neither the Status mode nor the Set Up mode activated, information is presented on the display in multiple pages referred to as the 'Main Rotation'.

To rotate through the different pages, press the [◀ BACK] or [NAV ▶] key.

6.1.1 MAIN ROTATION PAGES LAYOUT

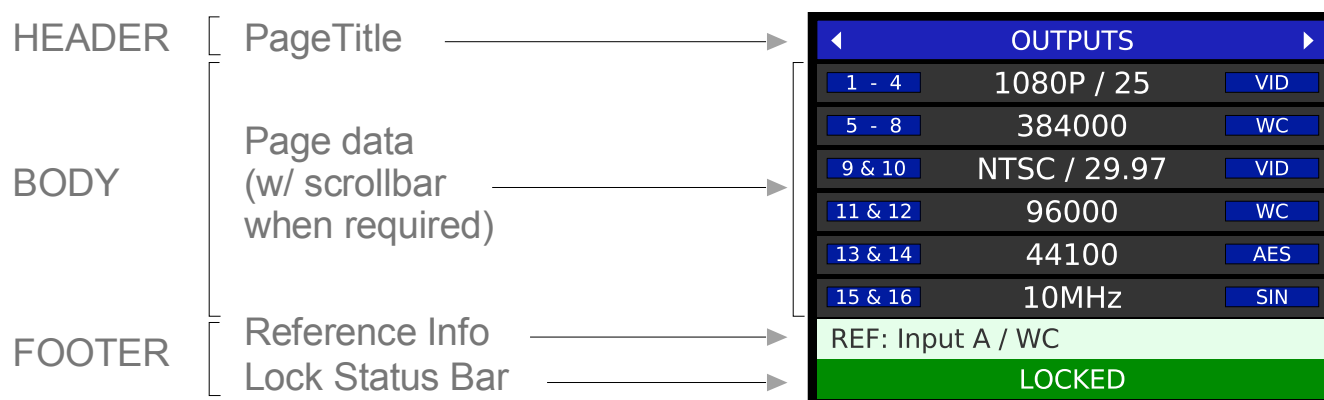

Pages in the main rotation all have a similar structure, made up of several lines arranged in 3 different sections:

- **HEADER (top line):**
Contains the page title. It has a blue background and white letters + left and right navigations arrows.
- **BODY:**
Contains the page data.
- **FOOTER (bottom 2 lines):**
 - Reference: source and errors or special conditions (see chapters 9 & 10).
 - Lock status. See chapter 11. The background color changes to reflect the lock conditions.

6.1.2 MAIN ROTATION PAGES

- **OUTPUTS**

This page indicates the rate, format and signal type of each of the 6 BNC output groups. The small blue boxes identifying each output group on the left side of the display change color to indicate timing deviation (see ch. 13).

- **PTP PORTS**

This page shows the setting and the state of each of the 4 PTP ports with colors for easy identification.

The setting first appears (as white letters on grey background):
Off, Master/Slave group, Independent Master.

Then the display indicates the state of the ports as they change in bold letters with the following background colors:

- SLAVE black letters yellow background
- GRANDMASTER black letters bright green background
- Indep. MASTER white letters blue background
- MASTER white letters green background
- Passive white letters dark grey background

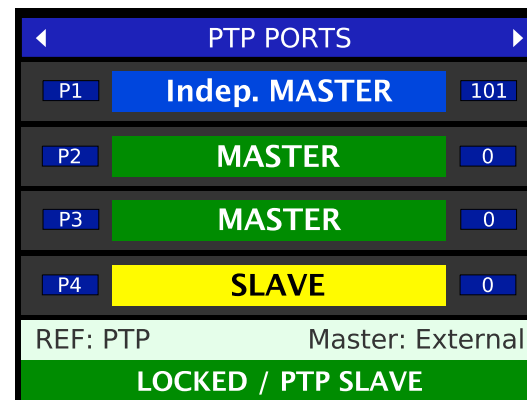

The PTP state of a port is determined by the BMCA. In a Master/Slave Group, if the DXD-16 is the grandmaster, all ports will assume that state; if not, one port will be 'SLAVE' the others 'MASTER'. The state of 'Independent Master' is for ports set as such in menu 5.1 that won the BMCA.

For details on these states, see Chapter 12, PTP Ports States.

- TIME & DATE

This page displays up to two different times & dates as set in menu 7.3.

The names of the DXD times selected in menu 7.3 appear in the left column while the name of the standards selected in menu 7.1 appear in the right column.

If 'NO DISPLAY' was set in menu 7.3 for the Lower Display, this page will only show 1 time & date.

TIME & DATE	
SYS	10:29:48 TAI
Apr 20 2020	
GPS	10:29:29 GPS
Apr 20 2020	
REF: Input A / WC	
LOCKED	

- REFERENCE SOURCES

This page shows the currently selected sources for Main and Alternate Reference. Also indicated are the rates and formats of the reference signals. When PTP MODE is the selected Reference, the display indicates if GPS has been selected as "LOCAL REF WHEN GM".

6.2 Status Mode

Additional information pages are available in the Status Mode. To enter the Status Mode, press the [STATUS] button. When in Status mode, the Status LED is on.

6.2.1 STATUS INFORMATION PAGES LAYOUT

Status pages are formatted similarly to the Main Rotation pages, with a green header but no footer. Up to 10 lines of information can be displayed on the screen at a time. A green scroll bar will appear on the left of the screen for pages with more than 10 lines.

To change page, use the [◀ BACK] and [NAV ▶] keys; to scroll, use the [UP] and [DOWN] keys.

6.2.2 STATUS INFORMATION PAGES

- UNIT INFORMATION

- Model
- Serial Number
- Version:
 - Software
 - Logic
 - Webpage
- Installed options:
 - DXD/GPS
 - DXD/OCXO
 - DXD/LTC

UNIT INFORMATION	
Model:	Brainstorm DXD-16
Serial Number:	1001
Versions:	
Software:	200
Logic:	106
Webpage:	000
Installed Options	
DXD / GPS:	Yes
DXD / OCXO:	No
DXD / LTC:	Yes

- NETWORK ADDRESSES

The following information is listed for each of the 4 networks:

- DHCP Mode
- IP Address
- Mac Address

- TIMES

The TIMES status page has multiple running counters showing the different DXD times available as well as an offset:

- System Time: Main DXD TOD clock
- RT Clock: continuously running internal back-up clock
- Grandmaster: time from the external PTP Grandmaster
- GPS (*optional*): GPS Time from the DXD/GPS receiver
- TOD-GM Ofst: indicates the offset between the internal Time Of Day clock and the Grandmaster in μ sec.

Additional status pages are also available for options such as GPS or Time Code.

6.3 Set Up Mode

In Set Up mode, all parameters are accessible and can be changed by the user via the front panel.

To enter the Set Up mode, press the [SET UP] button. The Set Up LED lights up. To exit the Set Up mode, press the [SET UP] key again and confirm that the Set Up LED is off.

6.3.1 MENU LEVELS

The Set Up mode has different levels. Typically, levels 1 & 2 are SELECT levels, made up of lists of menus organized in logical groups. The number of SELECT levels varies from 1 to 3 depending on the menu. For example, menu 8 (Presets) only has 1 SELECT level and menu 4 (Networks) has 3. The last level is the SET level, where parameters are set and saved.

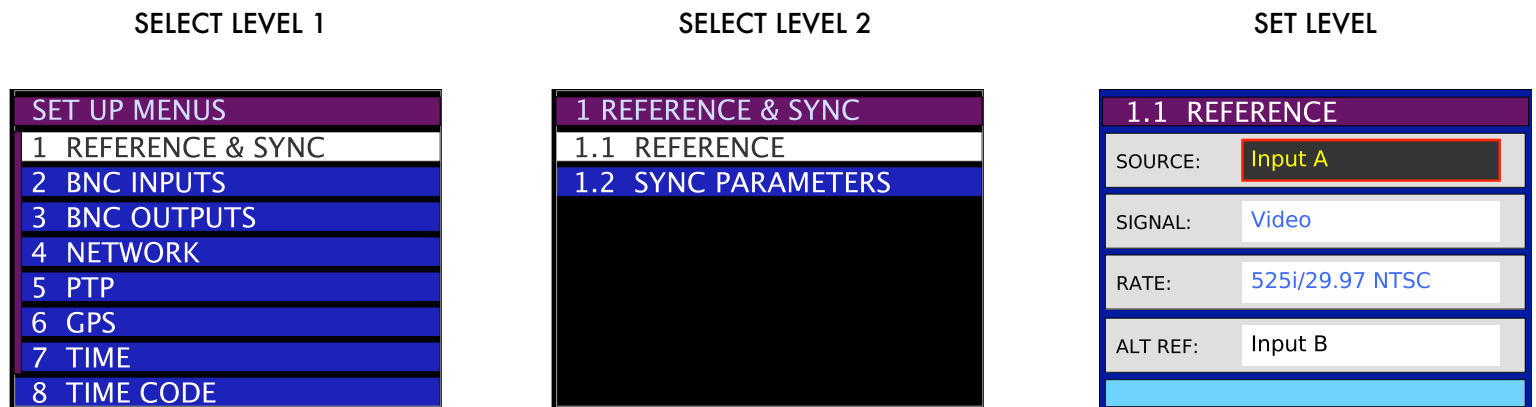

6.3.2 NAVIGATION

The navigation keys have different functions depending on the level.

- SELECT LEVELS (1, 2 or 3)
 - Use the [UP] and [DOWN] buttons to select a menu from the list. The current selection is highlighted (black letters, white background). Pressing the [down] button passed the lowest item on the list rotates back to the top of the list.
 - Press the [NAV ►] button to navigate to the next level.
 - Press the [◀ BACK] button to go back to the previous level.
- SET LEVEL
 - Use the [NAV ►] button to navigate to the next field. The currently selected field is highlighted (yellow letters on black background). Pressing the [NAV ►] button passed the last field on the page rotates back to the first one.
 - Use the [UP] or [DOWN] buttons to change the value of the selected field.
 - Use the [◀ BACK] button to go back to the previous Level and exit the current one.

6.3.3 ENTER KEY

After modifying a value, a red border around the edited field appears. To save this new value, press the [ENTER] key. After the [ENTER] key is pressed, the red border disappears, indicating the modification has been saved.

If the cursor is moved to another field without pressing the [ENTER] key first, the red border remains indicating a change was made but not saved yet.

To exit the Set Up mode without making any change, press the [SET UP] key without pressing the [ENTER] key. Note that exiting the SET Level by pressing the [◀ BACK] key without pressing the [ENTER] key first also causes unsaved changes to be lost.

6.3.4 STATUS VALUES

In the SET level, the line at the bottom of the display (light blue background) indicates status values. Status values are the values actually obtained, based on a menu selection.

6.3.5 MENU GROUPS

In the current firmware revision, menus are organized in 9 separate groups:

- 1. REFERENCE & SYNC
 - 1.1 Reference
 - 1.2 Sync Parameters
- 2. BNC INPUTS
 - 2.1 BNC Input A Set Up
 - 2.2 BNC Input B Set Up
- 3. BNC OUTPUTS
 - 3.1 BNC Outputs 1-4
 - 3.2 BNC Outputs 5-8
 - 3.3 BNC Outputs 9&10
 - 3.4 BNC Outputs 11&12
 - 3.5 BNC Outputs 13&14
 - 3.6 BNC Outputs 15&16
 - 3.7 Audio Base Rate A
 - 3.8 Audio Base Rate B
 - 3.9 Mute On Unlock
 - 3.10 Delay/Advance 1 - 4
 - 3.10 Delay/Advance 5 - 8
 - 3.10 Delay/Advance 9 & 10
 - 3.10 Delay/Advance 11 & 12
 - 3.10 Delay/Advance 13 & 14
 - 3.10 Delay/Advance 15 & 16
- 4. NETWORK
 - 4.1 Net 1
 - 4.2 Net 2
 - 4.3 Net 3
 - 4.4 Net 4
- 5. PTP
 - 5.1 Port Modes
 - 5.2 Grandmaster (Group)
 - 5.3 Port 1 (Controls, Timing, Independent Master, Time Jam)
 - 5.4 Port 2 (Controls, Timing, Independent Master, Time Jam)
 - 5.5 Port 3 (Controls, Timing, Independent Master, Time Jam)
 - 5.6 Port 4 (Controls, Timing, Independent Master, Time Jam)
- 6. GPS
 - 6.1 Satellites Selections
 - 6.2 GPS Settings
 - 6.3 Advanced GPS Settings
- 7. TIME
 - 7.1 Time Standards
 - 7.2 Real Time Clock
 - 7.3 Time & Date Display
 - 7.4 Leap Seconds
- 8. TIME CODE
 - 8.1 SMPTE 2059 Set Up
 - 8.2 TC GENERATOR 1
 - 8.3 TC GENERATOR 2
- 9. GPIO
 - 9.1 GPIO Inputs
 - 9.2 GPIO Outputs
- 10. PRESETS
- 11. UTILITY
 - 11.1 Brightness
 - 11.2 Front Panel Lockout
 - 11.3 Clear Memory
 - 11.4 Reboot
 - 11.5 Feature Keys

For detailed description of all the parameters and settings in each of these menus, go to chapter 7.

7. Menus Description

7.1 Reference

7.1.1 REFERENCE (MENU 1.1)

Menu 1.1 lets you select one of the following sources to be used as the DXD-16's reference:

- **Internal**
 - **BNC Input A**
 - **BNC Input B**
 - **PTP Mode**
 - **GPS** (available only with the optional GPS receiver - for information, see DXD/GPS users manual)
- INTERNAL is the DXD-16 oscillator (TCXO); if the OCXO option is installed, INTERNAL automatically uses the OCXO oscillator and the display indicates 'Internal/OCXO'.
 - BNC INPUTS A and B are defined in menus 2.1 and 2.2
 - PTP Mode is a little different. Selecting PTP Mode as the reference is required for the DXD-16 to be a PTP slave, i.e. 'referenced' to a PTP Grandmaster. However, selecting PTP Mode means that the DXD-16 ports set to 'Master/Slave Group' will participate in the PTP Grandmaster selection based on the BMCA (see 15.5). Explanatory text has been added to the REFERENCE select menu when PTP Mode is activated.

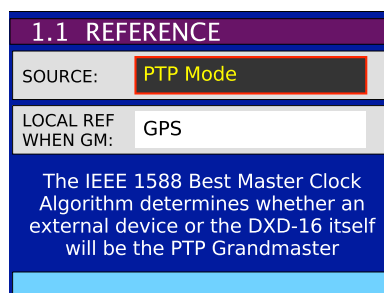

NOTE: When PTP Mode is selected, at least one of the ports needs to be set to 'Master/Slave Group' (menu 5.1). If not, the DXD will lock to its internal crystal and a warning message will appear on the display (see 23.Troubleshooting). The LOCK bar at the bottom of the Main Rotation display will also indicate NO PORT.

Additional Fields: Depending on which reference was selected, additional fields will appear below the SOURCE field:



- **SIGNAL and RATE:** when selecting Input A or Input B, these status field indicate the signal type and the rate of the selected reference, as defined in menus 2.1 and 2.2.
- **ALTERNATE REFERENCE:** when BNC INPUT A has been selected as the reference, BNC INPUT B can be set as an alternate source to be used as a fail-safe back up. Note that, to guarantee a smooth transition, both sources must have the same format and rate. For more on Alternate Reference, see chapter 10.
Note that, if there is no alternate reference, the DXD-16 will always revert to INTERNAL if the reference disappears.
- **LOCAL REF WHEN GM:** when PTP Mode is selected, if the optional DXD/GPS receiver has been installed, this fields enables the GPS to be set as the reference when the DXD-16 is the Grandmaster, giving the DXD-16 a better chance being selected by the algorithm.

There are no additional fields when the reference source is 'INTERNAL' or 'GPS'.

7.1.2 SYNC PARAMETERS (MENU 1.2)

Several parameters are available in this menu that control the way the DXD synchronizes.

- **BNC INPUT COLOR FRAMING:** color framing synchronization to video inputs can be enabled in this menu. "CF" indication will appear in the main rotation reference line when enabled and locked.
- **BNC INPUT TIME JAM SOURCE:** Selects the source of a Time Jam (see 8.2).
- **BNC INPUT TIME JAM RESYNC:** Used for a manual Time Jam (see 8.2)
- **PTP JUMP THRESHOLD:** When the difference between the internal TOD and the PTP reference is above the value entered, the DXD will not attempt a smooth transition (slew) but will instead jump instantly to the new time. Value can be adjusted from 5 msec to 15 sec, or set to 'Never'. Default value is 5 msec.

1.2 SYNC PARAMETERS	
BNC INPUT COLOR FRAMING:	On (NTSC/PAL only)
BNC INPUT TIME JAM SOURCE:	PTP Port 1
BNC INPUT TIME JAM RESYNC:	Press ENTER to Jam
PTP JUMP THRESHOLD:	5 msec

7.2 BNC Inputs

7.2.1 BNC INPUT A SET UP (MENU 2.1)

The 2 BNC Universal inputs can accept WC, AES (AES-3id unbalanced), 10 MHz and video sync (HD & SD - see Appendix A for a list of supported video inputs). Menu 2.1 lets you select the type of input connected to BNC INPUT A and its rate.

- **SIGNAL:** WC, AES, 10 MHz or Video Sync
- **LEARN/SET:** LEARN is the default value. With LEARN, the DXD-16 determines the incoming rate; with SET, the user determines the incoming rate. For more information on LEARN vs. SET, go to Chapter 9.
- **RATE:** If LEARN is selected, the rate field is Status only (pale Blue) and cannot be changed. If SET is selected, the user can select a rate from a list, based on the type of Signal selected.

7.2.2 BNC INPUT B SET UP (MENU 2.2)

Menu 2.2 is identical to menu 2.1 for BNC Input B except for the following.

If BNC INPUT B is set up differently than BNC INPUT A, a warning message appears on the bottom line: 'ALT REF INCOMPATIBLE'.

As mentioned above, to switch smoothly between 2 different sources in the event of a reference failure, these must be identical (see chapter 10 for more information on Alternate Reference).

7.3 BNC Outputs

The DXD-16 generates 6 different reference signals simultaneously, each of them sent to a different group of BNC outputs, as described below. Each of these universal output groups can output WC, AES, Video Sync or 10MHz.

7.3.1 BNC OUTPUTS 1-4 (MENU 3.1)

Menu 3.1 defines BNC outputs 1-4

- **SIGNAL :** this field defines the type of signal generated (WC, AES, 10 MHz or Video Sync).

Based on the signal selected, additional fields appear to define more parameters:

- Audio (WC or AES)
 - **BASE & MULT:** Base Rates A or B as defined in menus 3.7 or 3.8 followed by a multiplier (x1, x2, x4, x8)
 - **ACTUAL:** The actual rate will be indicated in blue letters (status info).

3.2 BNC OUTPUTS 5 - 8	
SIGNAL:	Wordclock
BASE & MULT:	Audio Base A x8
ACTUAL:	384000

- Video Sync (SD & HD)
 - **RATE:** select a video rate from a list (see appendix A).
- 10MHz
 - no additional field.

7.3.2 BNC OUTPUTS 5-8 (MENU 3.2)

Menu 3.2 is identical to menu 3.1 for BNC outputs 5-8.

7.3.3 BNC OUTPUTS 9&10 MENU (3.3)

Menu 3.3 is identical to menu 3.1 for BNC outputs 9&10.

7.3.4 BNC OUTPUTS 11&12 (MENU 3.4)

Menu 3.4 is identical to menu 3.1 for BNC outputs 11&12.

7.3.5 BNC OUTPUTS 13&14 (MENU 3.5)

Menu 3.5 is identical to menu 3.1 for BNC outputs 13&14.

7.3.6 BNC OUTPUTS 15&16 (MENU 3.6)

Menu 3.6 is identical to menu 3.1 for BNC outputs 15&16.

7.3.7 AUDIO BASE RATE A (MENU 3.7)

For audio outputs (Word Clock or AES), two different base rates are available, labeled Audio Base Rate A & B. Menu 3.7 defines Audio Base Rate A.

- **SET/AUTO:** SET is the default value; AUTO is a special function, available only when the input reference is an audio signal. With AUTO, the DXD-16 automatically determines the incoming rate and uses that as the base rate. The advantage is that, if the rate of the input reference changes, so does the generated output, automatically.

- **RATE:** If SET was selected, a rate can be selected from a list that includes 32K, 44.1K and 48K + all the pull coefficients (see appendix B). If AUTO was selected, the measured rate of the reference is displayed here (status only).

Note that, with AUTO selected, if the rate of the input reference is a multiple of one of the basic rates, 96K for example, the basic rate will be used instead, 48K in this example.

- **VSO/CENTS:** VSO (Variable Speed Oscillator) was used to vary the speed of old analog tape machines. This function, when activated, allows to vary the rate of the audio outputs, and thus the pitch. As this function is mainly used for musical applications, the speed adjustment is measured in cents (semi tone/100). The VSO range is +/- 200 cents, i.e. 2 whole tones (+12.2562% to -10.9101%). When VSO is on, the letters 'VSO' appear on the display next to the rate in the OUTPUTS main rotation page

NOTES: When adjusting the VSO cents value in the menu, the changes take effect immediately. There is no need to press [ENTER] for every speed change.

7.3.8 AUDIO BASE RATE B (MENU 3.8)

Menu 3.8 is identical to menu 3.7 for Audio Base Rate B.

7.3.9 MUTE ON UNLOCK (MENU 3.9)

To guarantee that the BNCs do not output any signal before the DXD achieves lock, which could cause issues with the receiving equipment, menu 3.9 lets you mute the outputs while unlocked.

On = mute - Default value is off.

Each of the 6 output groups can be set independently: 1-4 / 5-8 / 9&10 / 11&12 / 13&14 / 15&16.

7.3.10 DELAY/ADVANCE 1 - 4 (MENU 3.10)

This menu enables to delay or advance WC, AES or Video Sync out of this group of BNC outputs (1-4) by a set amount.

3.10 DELAY/ADVANCE 1 - 4					
ENABLE:	Delay				
MICRO SECONDS (USEC):	0	0	0	1	0
CLEAR:	No Action				

- **ENABLE:** Choices are Off / Delay / Advance. Selecting DELAY or ADVANCE will delay or advance the signal by the amount entered in the next field.

If the signal selected for this output group does not support this function (10MHz or Time Code), the display will say 'Unavailable for signal' in blue letters indicating it cannot be changed.

- **MICRO SECONDS (USEC):** The offset value in micro seconds is made up of 5 separate fields, the one on the far right for μ sec, the one on the far left for the tens of msec.
The offset can vary from 1 μ sec (or 00001 μ sec) to 99999 μ sec (or 99.999 msec).
- **CLEAR:** To clear the value in the field above, toggle to 'PRESS ENTER TO CLEAR' and press the ENTER key.

7.3.11 DELAY/ADVANCE 5 - 8 (MENU 3.11)

Menu 3.11 is identical to menu 3.10 for BNC outputs 5-8.

7.3.12 DELAY/ADVANCE 9 & 10 (MENU 3.12)

Menu 3.12 is identical to menu 3.10 for BNC outputs 9&10.

7.3.13 DELAY/ADVANCE 11 & 12 (MENU 3.13)

Menu 3.13 is identical to menu 3.10 for BNC outputs 11&12.

7.3.14 DELAY/ADVANCE 13 & 14 (MENU 3.14)

Menu 3.14 is identical to menu 3.10 for BNC outputs 13&14.

7.3.15 DELAY/ADVANCE 15 & 16 (MENU 3.15)

Menu 3.15 is identical to menu 3.10 for BNC outputs 15&16.

Acknowledgment on the OUTPUTS Page of ADVANCE/DELAY activation

The OUTPUTS page on the main rotation display will indicate that a BNC output signal has been advanced or delayed by replacing the blue rectangle with the output format in the right column of the corresponding output group by a red rectangle.

OUTPUTS		
1 - 4	1080P / 25	VID
5 - 8	48000	AES
9 & 10	NTSC / 29.97	VID
11 & 12	384000	WC
13 & 14	TCG 1	29DF
15 & 16	TCG 2	30ND
REF: PTP		Master: External
LOCKED / PTP SLAVE		

In the illustration above, Outputs 9 & 10 are either delayed or advanced.

Note that even if the value entered is '00,000', the red rectangle will still be show up on the display. To return to blue, the feature must be turned off (i.e. the ENABLE field must be set to OFF).

7.4 Network

The Network menu has 4 identical and separate sub-menus, one for each of the DXD-16 ports.

7.4.1 NET 1 (MENU 4.1)

7.4.1.1 NET 1 IP ADDRESS (MENU 4.1.1)

Menu 4.1.1 includes fields for DHCP, IP Address, Subnet Mask and Gateway.

DHCP stands for Dynamic Host Configuration Protocol. When on, the DHCP server automatically assigns the IP address. The values in the 3 other fields are in blue, indicating status only.

When DHCP is off, parameters must be entered manually in the next 3 fields. They are expressed in dot-decimal notation made up of 4 numbers ranging from 0 to 255, separated by dots.

The bottom line on the display (blue background) indicates the current IP address.

Note that, when changing the DHCP mode, a reboot will be required and a message will indicate so in the display.

7.4.2 NET 2 (MENU 4.2)

7.4.2.1 NET 2 IP ADDRESS (MENU 4.2.1)

Menu 4.2.1 is identical to menu 4.1.1 for Net 2.

7.4.3 NET 3 (MENU 4.3)

7.4.3.1 NET 3 IP ADDRESS (MENU 4.3.1)

Menu 4.3.1 is identical to menu 4.1.1 for Net 3.

7.4.4 NET 4 (MENU 4.4)

7.4.4.1 NET 4 IP ADDRESS (MENU 4.4.1)

Menu 4.4.1 is identical to menu 4.1.1 for Net 4.

7.5 PTP

This chapter describes the PTP menu settings. For general information on PTP, go to chapter 15.

7.5.1 PORTS MODES (MENU 5.1)

Each of the 4 DXD-16 ports can be set as:

- **Master/Slave group**
 - **Independent Master**
 - **Time Jam (BNC Input)**
 - **Disabled**
- The 'Master/Slave group' setting is typically used to set the DXD-16 as a boundary clock where one port would be slave to an external grandmaster and the others masters to what is 'downstream', i.e. what is connected to that port (see first diagram in chapter 15). This master/slave set-up could change as the BMCA determines which is the grandmaster. Like a Boundary Clock, ports on a Group are all on the same domain.

Unlike a Boundary Clock, a Group does not require one of the ports to be a slave. If a reference other than PTP is selected in menu 1.1, a message at the bottom of menu 5.1 will indicate "Master-only while Reference not PTP" and all ports in the group will be Master-only. If the BMCA elects another unit as the PTP Grandmaster, those ports become PASSIVE.

Note that, per IEEE 1588, *if multiple ports of a boundary clock communicate to the same communication path (i.e. "see" each other), the boundary clock shall place all of the involved ports in the PASSIVE state, except the port with the lowest portNumber.* This rule applies to the group setting (see ch. 12 on PTP Ports States).

- Ports set to 'Independent Master' can only be PTP Masters, not slaves, and are not part of the group. They are all on separate PTP domains. If the BMCA elects another unit as the PTP Grandmaster for that domain, this port becomes PASSIVE.
- Ports set to 'Time Jam (BNC Input)' will forward time information from a PTP master to the TOD (see Time Jam ch 8.2).

To view the state of the PTP ports, go to the PTP Ports page of the main rotation display (see 6.1.2).

7.5.2 GRANDMASTER [GROUP] (MENU 5.2)

This menu lets you set the following fields for the ports set to 'Master/Slave group'.

- Domain: 0 to 127; default = 0
- Priority 1: 0 to 255; default = 128
- Priority 2: 0 to 255; default = 128

Priorities are used in the BMCA to select the grandmaster - lower values have a higher priority.

7.5.3 PORT 1 (MENU 5.3)

Menu 5.3 has 3 sub-menus for setting different parameters related to port 1:

7.5.3.1 Port 1 Controls (Menu 5.3.1)

- Profile: Several profiles are supported by the DXD-16:
 - PTP - Default PTP profile
 - AES 67
 - ST2059
 - AVB - upcoming revision

- Profile Port Timing Action:

Among other things, IEEE1588 profiles define the range and default values of all configurable attributes. This is very useful as selecting a specific profile on several networks would set all the parameters to the default values and allow for a quick set up. However, if multiple profiles are selected in a Boundary Clock using profile default values could become troublesome. In the case of the *Announce Interval* for example, these values need to be uniform throughout a domain for the BMCA to function properly but AES67 and ST2059 have different default values.

This field gives you the option to set the timing values to the profile default values.

- Delay Mechanism: E2E / P2P / Disabled

Two delay modes are available: End-to-End and Peer-to-Peer.

In End-to-End mode, the sync, follow up, delay request and delay response messages go through the network all the way between the master and slave.

In Peer-to-Peer mode, the Pdelay request and Pdelay response messages are local to each link in the network. Each device determines the local link and device delays. The sync message from the master then collects the corrections as it propagates from the master to slave.

End-to-End mode is useful in PTP networks using not-PTP-aware devices. By contrast, Peer-to-Peer mode requires all of the devices to be PTP-aware.

7.5.3.2 Port 1 Timing (Menu 5.3.2)

- Announce Interval: 1/8sec - 16sec (log -3 to 4)

Sets the rate at which the master will send Announce messages.
Per IEEE 1588 this value should be uniform throughout a domain.

- Announce Receipt Timeout: 2 to 10 announce intervals

Sets the number of Announce messages that can be missed before it is assumed the master is no longer present and the process of selecting a new one begins. Per IEEE 1588 this value should be uniform throughout a domain.

- Sync Interval: 1/128sec - 2sec (log -7 to 1)

Sets the rate at which the master will send Sync messages

- Min Delay Req Interval: 1 to 32 the number of Sync Interval

Sets the minimum time interval between 2 adjacent Delay Requests. This field shows a quantity of sync intervals: "n sync intervals", where n = 1,2,4,8,16,32 (when n=1 it will say "1 sync interval"). This change does **not** apply to the peer-to-peer "MIN PDELAY REQ INTERVAL".

7.5.3.3 Port 1 Independent Master (Menu 5.3.3)

This menu only appears if the port has been set to 'Independent Master' in the Ports Mode menu (menu 5.1) It is identical to menu 5.2 and let you set the following fields:

- Domain: 0 to 127; default = 101 port1/ 102 port 2/ 103 port 3/ 104 port 4
- Priority 1: 0 to 255; default = 128
- Priority 2: 0 to 255; default = 128

Priorities are used in the BMCA to select the grandmaster - lower values have a higher priority.

7.5.3.4 Port 1 Time Jam (Menu 5.3.4)

The domain of the port used for Time Jam (see ch 8.2) must be the same as the one of the external PTP master (source).

7.5.4 PORT 2 (MENU 5.4)

Menu 5.4 is identical to Menu 4.3 and its 4 sub-menus for port 2.

7.5.5 PORT 3 (MENU 5.5)

Menu 5.5 is identical to Menu 4.3 and its 4 sub-menus for port 3.

7.5.6 PORT 4 (MENU 5.6)

Menu 5.6 is identical to Menu 4.3 and its 4 sub-menus for port 4.

7.6 GPS

The GPS group of menus is only available if the DXD/GPS receiver is installed. If not a message will appear:

DXD/GPS NOT INSTALLED
The GPS Receiver is required for these menus.

The DXD/GPS is an optional board that installs easily inside the DXD. For menu details, please refer to the DXD/GPS manual.

7.7 Time

7.7.1 TIME STANDARDS (MENU 7.1)

Four different time standards are available as well as local time:

- **TAI**: International Atomic Time, an atomic coordinated time that has been measuring time continuously since 1955 with no leap seconds. It is used as a base by other standards such as UTC.
- **UTC**: Coordinated Universal Time is the time zone '0' from which all other time zones are calculated. It is based on TAI and since 1972 has had leap seconds every year or so, depending on the earth's rotation.
- **GPS**: Global Positioning System time is used by the atomic clocks in the GPS satellites. It is continuous time (no leap seconds) measured from the GPS time zero point of midnight January 5, 1980. It is 19 seconds behind TAI.
- **Loran**: Long Range Navigation time based on atomic clocks. Like GPS, it is continuous time with no leap seconds measured from the time zero point of midnight January 1st, 1958.
- **Local**: Local time is based on UTC and can have adjustments for time zone and Daylight Saving (menu 7.1).

Menu 7.1 lets you pick which of these standards or local time will be used to display the following DXD times:

- **System Time**, the main Time Of Day clock at the heart of the DXD
- **RTC**, Real Time Clock, a constantly running, battery-backed-up clock inside the DXD

- **Grandmaster**, time received on the Ethernet port from the PTP Grandmaster
- **GPS**, time received from the GPS receiver (*optional*)

To avoid confusion, it is recommended to use one standard for all DXD times. The default value is TAI. But some users may prefer to use Local Time instead while others may even prefer different standards for different times.

Be aware that, even though the time source may give Time Of Day, it may not correspond to the time indicated on a wall clock as it would depend on the standard used or even on the accuracy and settings of the source time.

There are 2 other Local Time parameters in menu 7.1:

- **Time Zone**: can be adjusted in hours and minutes with a positive or negative value, relative to UTC (or GMT)
- **Daylight Saving**: can be adjusted in hours and minutes (typically 1 hr). DST can only be set manually.

7.1 TIME STANDARDS		
SYSTEM / RT CLOCK:	TAI	TAI
PTP GM / GPS:	TAI	TAI
LOCAL TIME ZONE:	-8 Hrs	00 Min
LOCAL DAYLIGHT SAVING:	0 Hr	00 Min
Time zone examples: NY -5, Tokyo +9		

At the bottom of this page a 'hint' message appears for setting the time zone properly: NY -5, Tokyo +9.

7.7.2 REAL TIME CLOCK (MENU 7.2)

Menu 7.2 lets you set several parameters of the RTC (Real Time Clock), the DXD internal back up clock described in chapter 11.

- **Set Time: YYYY/MM/DD and HH:MM:SS**: These fields let you enter manually a date and a time that will become the current date and time of the RTC when the [ENTER] key is pressed.
- **System Time Jam From RT Clock**: With 'Press ENTER to Jam' selected, the Main TOD Clock (System Time) will Jam from the internal RTC Time when the [ENTER] key is pressed.

Note that depending on the offset between the 2 clocks, this action will most certainly create a certain amount of 'sync shock' as all the outputs are locked to the System Time.

- **Auto Update RT Clock**: When this function is turned on, the RTC is automatically updated with the date & time information from GPS. This update occurs within a second of when the feature is turned on, then every 1.2 hr. Options are "From GPS" or "Off".

7.2 REAL TIME CLOCK		
SET TIME: YYYY/MM/DD	2020	05 22
SET TIME: HH:MM:SS	07	01 18
SYS TIME JAM FROM RT CLOCK:	Press ENTER to Jam	
AUTO UPDATE RT CLOCK:	From GPS	
RT Clock: 2020/05/22 07:05:25 TAI		

This field does not appear if the DXD/GPS card is not installed.

At the bottom of this page the RTC Time is displayed along with the Time Standard set up in menu 7.1

7.7.3 TIME & DATE DISPLAY (MENU 7.3)

Menu 7.3 lets you select 2 different DXD times & dates to be displayed in the Time & Date display (see 6.1.2 Main Rotation). The choices are:

- System Time
- Real Time Clock
- Ext PTP Grandmaster
- GPS Receiver (*DXD/GPS option required*)
- No display (lower display only)

The times and dates displayed will match what has been set in menu 7.1 and that setting will appear to the right of the time.

7.7.4 LEAP SECONDS (MENU 7.4)

- **UTC Leap Second**: Menu 7.4 lets you enter manually the number of leap seconds to be applied to TAI.
- **Auto Update**: This fields lets you set the DXD so that the leap seconds will be updated automatically based on data from GPS. Options are "From GPS" or "Off".

This field does not appear if the DXD/GPS card is not installed..

7.8 Time Code

Menu group #8 (Time Code) includes SMPTE 2059 setup parameters as well as the menus for the optional time code generator, DXD/LTC.

7.8.1 SMPTE 2059 SETUP (MENU 8.1)

Menu 8.1 has settings for Daily Jam when using the ST2059 PTP profile. Even without the DXD/LTC option, the DXD-16 will still pass these to devices on the network via PTP Management messages.

- **Daily Jam Time:** This parameter lets you enter the time of the daylight jam.
- **Manual Daily Re-Jam:** To manually activate a daily jam, selected Press ENTER to Jam, then press the ENTER key.

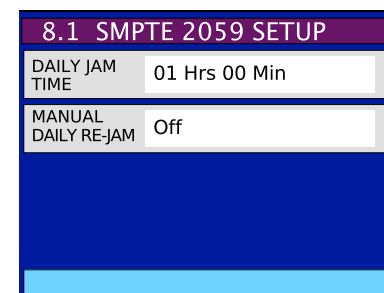

7.8.2 LTC GENERATOR 1 & 2 (MENUs 8.2 & 8.3)

Menus 8.2 and 8.3 require the DXD/LTC. Otherwise, when trying to access these menus, a message will appear indicating that the Feature Key has not been found. Please refer to the DXD/LTC manual for information. To purchase the DXD/LTC, please contact your Brainstorm Electronics dealer.

7.9 GPIO

The DXD-16 has 3 GPIO inputs and 4 outputs. They are accessible via the rear panel DB-25 connector (see Appendix E). GPIO Inputs and Outputs are both active low. Menus 9.1 and 9.2 let you select a function for each of these I/O's.

7.9.1 GPIO INPUTS (MENU 9.1)

- | | |
|-------------------------|--|
| - Status Clear Function | Clears any error |
| - Force Time Jam | The equivalent of a BNC INPUT TIME JAM RESYNC (menu 1.2) |
| - Off | Disabled |

7.9.2 GPIO OUTPUTS (MENU 9.2)

- | | |
|------------------------|--|
| - Locked | Stays low while status is LOCKED |
| - Unlocked | Stays low while status is Not-LOCKED |
| - Unlocked Hold | Stays low until cleared after status becomes Not-LOCKED |
| - Power Fail Hold | Stays low until cleared after one of the power sources fails (same as power LED) |
| - Error Hold | Stays low until cleared, when an error occurs |
| - Error Pulse | One time 200 ms low pulse, when an error occurs |
| - Jump Hold | Stays low until cleared, when DXD-16 jumps to re-sync |
| - Jump Pulse | One time 200 ms low pulse, when DXD-16 jumps to re-sync |
| - PTP Slave | Stays low while status is PTP SLAVE |
| - PTP Grandmaster | Stays low while status is PTP GRANDMASTER |
| - GPS Antenna Fail | Is active (low) when (a) a GPS card is installed, (b) it is running, and (c) the antenna is not connected, or is malfunctioning in such a way that it appears to be so |
| - Power On | Stays low while unit is on - Requires an external pull-up resistor (for example 20K ohms to +5VDC) to create a high level when the unit is off |
| - Time Jam in Progress | System is locking to the Time Jam source |
| - Off | Disabled |

When the 4th output is not used as a GPO, it is a 1PPS output, 5v CMOS, high pulse.

7.10 Presets

Ten different user settings configurations can be stored for quick recall. The 10 memory locations are labeled Preset 1 through Preset 10.

Menu 10 manages the presets. After selecting a preset, there are 5 different actions to chose from:

- Save
- Recall
- Delete
- Change Name
- Clear Name

When Saving, Recalling or Deleting a preset, a confirmation dialog appears on the display.

An 8 character name can be given to each preset using the Change Name and Clear Name commands.

7.11 Utility

7.11.1 BRIGHTNESS (MENU 11.1)

Menu 11.1 lets you adjust the brightness of the LCD display and of the LED's. Values range from 00 to 16, default value is 10. These changes take place immediately without having to press the [ENTER] key.

7.11.2 FRONT PANEL LOCKOUT (MENU 11.2)

Menu 11.2 lets you disable the front panel to avoid accidental changes. Options are On / Off. As in menu 11.1, pressing the [ENTER] key is not required.

When 11.2 is on, if a change is attempted, a 'FrontPanelLockOut' error message appears in the display.

7.11.3 CLEAR MEMORY (MENU 11.3)

In menu 11.3, pressing the [ENTER] key clears all the settings stored by the user in the flash memory, except for the presets. It also causes the DXD-16 to reboot. This will revert the unit to the **factory presets**, restoring the default values described in Appendix F.

7.11.4 REBOOT (MENU 11.4)

In menu 11.4, pressing the [ENTER] key is the equivalent of cycling power. Confirmation will be required for this action.

7.11.5 FEATURE KEYS (MENU 11.5)

This menu is for entering authorization codes to enable certain features such as Time Code.

8. Time of Day

Time of day is an essential component of the DXD-16. In a PTP network, the devices all need to know the Time of Day, i.e. year, month, day, hour and seconds, even nanoseconds, to achieve frequency and phase synchronization. At the heart of the DXD-16 is the Internal Time of Day Clock (TOD) & Reference Frame Generator. This is where the System Time is generated and where the references generated by the DXD-16 are aligned with the PTP epoch.

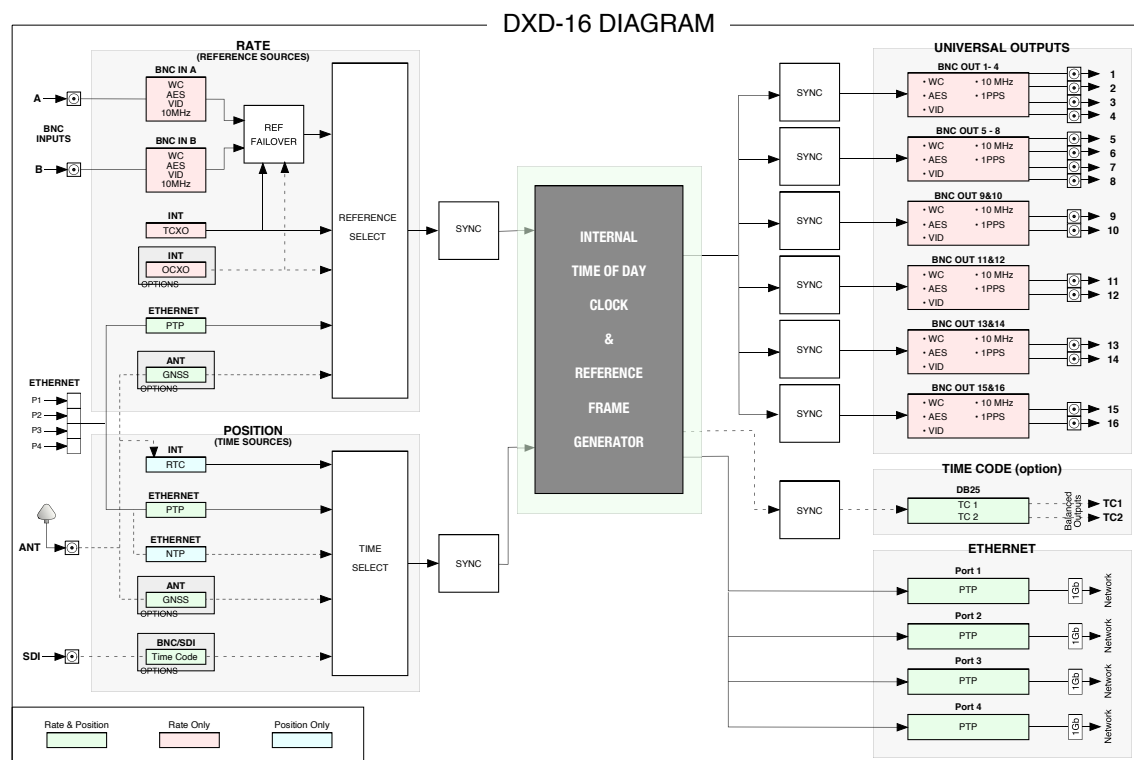

As shown on the diagram above, some of the reference sources include time and rate information. GPS and PTP for example carry precise time and date information as well as frequency. However, traditional reference signals, such as video sync or word clock, only carry the frequency information. When selecting one of those as reference (BNC inputs), the time information needs to be added from another source. The DXD-16 offers several options.

IMPORTANT NOTE

When using a reference without time information such as video sync, there will be an adjustment in the TOD count so that video frame edges are correctly aligned. The internal TOD is always creating internal frame references that are aligned as required with Jan 1, 1970 (PTP epoch). To lock to an external frame edge the DXD has to move the TOD count by up to +/- half a frame to synchronize the internal TOD frame edge to the incoming edge.

8.1 RTC (Real Time Clock)

A backup clock, called the RTC (Real Time Clock) is included in the DXD. It is set at the factory (date & time) and runs continuously, even when the unit is turned off as it is powered by an internal battery.

The DXD uses the date & time information from the RTC just after power up and transfers it to the main TOD (System Time). When locking to a new reference, if that reference does not have date & time, the TOD simply continues counting along its current time sequence; if it has date & time, that information is transferred to the TOD.

Although the RTC is set at the factory, it can also be set manually by the operator or be updated automatically (if GPS is available) via the Real Time Clock menu (menu 7.2).

7.2 REAL TIME CLOCK			
SET TIME:	2020	05	22
YYYY/MM/DD			
SET TIME:	07	01	18
HH:MM:SS			
SYS TIME	Press ENTER to Jam		
JAM FROM RT			
CLOCK:			
AUTO UPDATE	From GPS		
RT CLOCK:			
RT Clock:	2020/05/22	07:05:25	TAI

8.2 Time Jam

The BNC inputs can accept Word Clock, AES, Video Sync or 10 MHz. As none of those signals has date and time information, when one is selected as reference, the DXD-16 can be set to receive time information from another source. Current choices are PTP and GPS (when available). Since the DXD-16 can only lock to one reference at one time, this would take place as a Time Jam, meaning that the DXD-16's TOD will be reset to the time of the master source before locking to the BNC input.

8.2.1 TIME JAM TO PTP

When PTP is selected as the source of TIME JAM (menu 1.2), the DXD-16 will first lock its internal Time of Day clock to PTP. When that is achieved, the DXD-16 will release the PTP Lock and revert to the BNC source selected in the reference menu.

8.2.1.1 What is the sequence of a complete Time Jam to PTP?

1. LOCK TO PTP: The DXD-16 Lock status indicates HOLD / PTP SYNC on dark pink background.
2. CONFIRMATION: A message confirms that the date and time information has been transferred to the internal Time of Day successfully (clearing of this message is required).
3. LOCK TO THE BNC INPUT: The DXD-16 indicates it is locked to the BNC reference, Input a / Video in this example.
4. SYSTEM TIME UPDATED: The System Time now indicates the same time as the PTP source



8.2.1.2 What is required for a Time Jam to PTP?

1. Reference must be BNC A or BNC B (menu 1.1). That BNC input must be set properly in menu
2. A PTP port must be selected as the BNC INPUT TIME JAM SOURCE (menu 1.2). This port will now show as set for Time Jam [BNC Inputs] in menu 5.1 (blue letters indicate status and cannot be altered)
3. The PTP domain of the Time Jam Port must be set to the same domain as the PTP source in the proper menu (5.3.4: P1/ 5.4.4: P2/ 5.5.4: P3/ 5.6.4: P4)

8.2.2 OTHER TIME SOURCES - GPS

With the DXD/GPS option installed, GPS can be used as a source for a Time Jam.

For more information on GPS, please refer to the DXD/GPS manual.

8.2.3 DISPLAY & PORT STATES

At the bottom of the Main Rotation display, in the REFERENCE line, the words 'Time Jam' appear in brackets to confirm that TIME JAM has been selected. On the PTP PORTS main rotation page, the possibilities for a port in Time Jam mode are:

- **Time Jam** (in the smaller font, white on grey): this *may* show up for a short time when time jam is first invoked, and prior to being activated.
- **Listening** (in bold font, white on grey): time jam has been activated, but the port has not yet been put into the SLAVE state by the BMCA.
- **TIME JAM** (in bold font, black on light pink): time jam is currently active and processing the jam.
- **Time Jam (idle)** (in bold font, white on grey): the time jam process has completed. The port is still technically in the SLAVE state, which allows the DXD-16 to continue monitoring the TOD-GM offset. But the grandmaster time information is not otherwise being used.

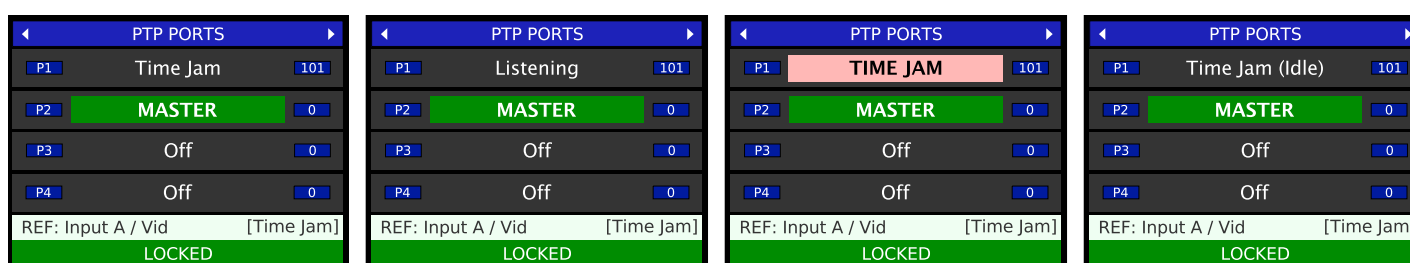

The TIMES Status Page shows the offset between the internal TOD clock and the external Grandmaster (TOD time - GM time) in μsec . It is relevant only when the device is either (a) a standard PTP slave, or (b) in Time Jam mode. When doing a Time Jam, if the reference is not synchronous with the Grandmaster, there will most likely be a drift and the TIMES page will indicate the current offset.

TIMES		
System Time:	2020/04/20 14:11:45	TAI
RT Clock:	2020/04/20 14:11:45	TAI
GPS:	2020/04/20 14:11:45	TAI
Grandmaster:	2020/04/20 14:11:45	TAI
TOD-GM Ofst:	+0	usec

8.2.4 COLOR FRAME AND TIME JAM

The internal TOD is always creating internal frame references that are aligned as required with Jan 1, 1970 (PTP epoch). This means that when locking to any of the BNC input references, there will be a date & time adjustment in the TOD count to align the frame edges correctly. When referencing the DXD to video sync with Color Frame (Pal or NTSC only) the TOD shift could be more important as the CF sequence can be as long as 4 frames. Color Framing synchronization is set in menu 1.2.

8.2.3 PRACTICAL APPLICATIONS OF TIME JAM

When the reference does not include time and date information such as video sync for example, the System Time will be used or the internal RTC (Real Time Clock) when the unit is turned on. But that may not correspond to Time of Day. That could be problematic when generating PTP sync referenced to video sync.

But doing a Time Jam from PTP or GPS will guarantee that the generated PTP sync will have the correct Time of Day. Of course, the only way for the TOD generated by the DXD to remain synchronous with the PTP or GPS source is for the video sync reference to be locked to GPS or PTP as well. Otherwise, they will drift.

Time Jam also allows for 2 DXD referenced to video sync to be set up as redundant PTP generators.

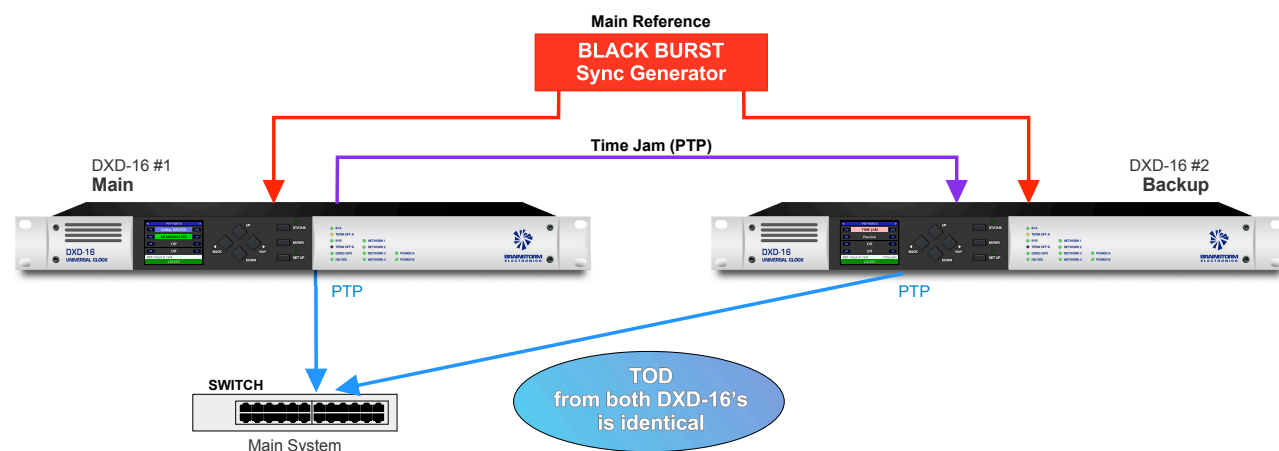

Note that, in the scenario above, as both DXD-16's are locked to the same reference (Black Burst), the TIMES Status Page on DXD-16 #2 will confirm that the offset is '0 μsec ' and no drift is occurring (see 8.3.2 above).

9. Input rate: Learn vs. Set

9.1 BNC INPUT SET UP MENU

In the BNC Input Set Up menus (menus 2.1 and 2.2), the DXD-16 offers a choice between LEARN and SET:

- LEARN: the DXD-16 measures the input reference and determines it's rate;
- SET: the user defines the expected rate.

Most of the time LEARN will work fine and it is the default value. However, at times, the user may choose SET to be sure the DXD-16 does not misinterpret an input frequency which is slightly incorrect. The SET mode may also be chosen for more fail-safe operation, in that there is no chance that the DXD-16 will re-define a frequency which drifts over time.

To illustrate this, let's look at a reference frequency of 95,950Hz. This frequency is slightly below the standard 96k rate but slightly above the pulled down 96k (95,904Hz). If the unit uses this source as reference, here are the 2 possible scenarios:

- If the DXD-16 interprets this as 96k, it will run slow by 0.052%;
- if it interprets it as a pulled down 96k, it will run fast by 0.047%

In SET mode, the user can make that choice; in LEARN mode, the DXD-16 automatically selects the closest frequency, i.e. the pulled down 96K in this case.

9.2 ABOUT USING THE 'SET' MODE FOR THE REFERENCE SOURCE

When choosing SET for the rate of the reference source, there is the possibility that the selected rate will not match the measured rate (actual rate). If that is the case, the DXD-16 will still lock to the reference but the output frequencies will be adjusted proportionately.

For example, if the input reference is SET for PAL, and NTSC video reference is connected, an output frequency requested at 44,100Hz will actually be 52,867Hz ($44100 \times 29.97/25$).

WARNING: When using this function, the user can potentially mislead the DXD-16 and affect the output frequencies. This could be done intentionally to repair prior errors, but caution must be used.

9.3 OFFSPEED REFERENCE

When the reference is detected to be off speed by more than 0.075%, the Lock bar at the bottom of the status displays indicates the message 'OFFSPEED' in the left third with different color background:

As this may be intentional (see 9.2 above) the background color is orange (warning color), not red (error color). But, as mentioned above, caution must be used with offspeed reference as it affects the outputs.

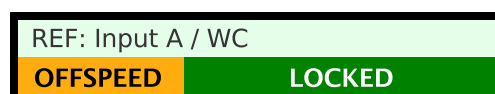

10. External Reference Failover (BNC)

In the event of failure of the external reference, the DXD-16 has 2 different scenarios to insure that the Sync outputs remain safely uninterrupted.

10.1 REFERENCE FAILURE WITH AN ALTERNATE REFERENCE

Menu 1.1 allows for the second BNC input to be used as an alternate reference. With that function enabled, if the main reference disappears or becomes unreadable, the DXD-16 goes from LOCKED to HOLD and displays a 'REF ERROR' message on the right side of the reference line. Once it recognizes the alternate reference, it indicates 'ALTERNATE' in place of the error message and goes through the normal locking procedure, displaying the appropriate status messages in the Lock bar at the bottom of the display (HOLD/FEQ LOCK > HOLD/SYNC > TIME SYNC > OUTPUT ALIGN > LOCKED). As both reference sources are identical, this transition should happen smoothly and without any deviation on the outputs.



The DXD-16 will stay locked to the Alternate reference with the 'ALTERNATE' message in the reference line, even if the original reference reappears.

If the alternate reference fails and the original reference is present, the DXD-16 switches back to the original reference in the same sequence as the one described above. If the original reference is not present, the DXD-16 switches to the Internal crystal as described below.

10.2 REFERENCE FAILURE WITH NO ALTERNATE REFERENCE

If the Alternate Reference function was disabled in menu 1.1 and the main reference disappears or becomes unreadable, the DXD-16 goes from LOCKED to HOLD and displays a 'REF ERROR' message on the right side of the reference line. The DXD-16 stays in the HOLD mode until the reference reappears at which point the DXD-16 automatically goes back into the lock sequence.

11. Lock Status

The lock status of the DXD-16 is indicated in the lock bar at the bottom of the Main Rotation display. The background color changes to reflect the lock condition so it can be clearly visible from a distance. Below are the different statuses and what they indicate:

HOLD / PTP SYNC	system getting frequency and position aligned with PTP grandmaster
HOLD	input reference unavailable, holding frequency and position
HOLD / FREQ LOCK	internal primary frequency adjustments
HOLD / SYNC	general synchronization adjustments
TIME SYNC	Time-of-Day adjustments
OUTPUT ALIGN	output channel synchronization
LOCKED	locked

11.1 LOCK STATUS & PTP

When PTP Mode is selected in the reference menu, the Ref line indicates 'REF: PTP' with 4 different options to its right:

- "Master: External"
- "Master: Internal"
- "Master: Internal / OCXO"
- "Master: GPS Receiver"

As described earlier, selecting PTP Mode in the reference menu means that the DXD-16 will participate in the PTP Grandmaster selection (see 15.5, Selecting a Grandmaster). If another unit is selected by the BMCA, "Master: External" will be displayed. If the DXD-16 is selected, one of the other 3 options will be displayed.

The bottom line has the usual LOCK status, but in the case where the DXD-16 is the grandmaster (and is locked) it changes to "LOCKED / GRANDMASTER".



In case a unit other than the DXD is or becomes the PTP Grandmaster the display changes to "LOCKED / PTP SLAVE".



Note that, if another source was selected in the reference menu, such as Video Sync for example, and the DXD-16 was simultaneously a PTP Grandmaster on any of the ports, the same LOCK status would appear, but the REF line would indicate "REF: Input A / Vid" (see 7.5.1 on PORTS MODE).



12. PTP Port States

One of 3 different modes can be assigned to each port in menu 5.1: 'Master/Slave Group', 'Independent Master' or 'Off'. Based on those selections, PTP messages are exchanged and each port goes into a PTP state. The choices are:

- **SLAVE**: in M/S Group mode (boundary clock) - state of the slave port (connected to the external grandmaster).
- **GRANDMASTER**: in M/S Group mode - when DXD-16 won the BMCA, all ports are in the state of Grandmaster.
- **INDEPENDENT MASTER**: in Independent Master mode - state of a port when it won the BMCA (in its domain).
- **MASTER**: in M/S Group mode (boundary clock) - state of the master ports (those distributing the master clock).
- **Passive**: - in M/S Group mode - state of a Master port that 'sees' another master port from the same DXD-16 or,
- in Independent Master mode - state of the port when the BMCA selects another unit as master (in its domain).

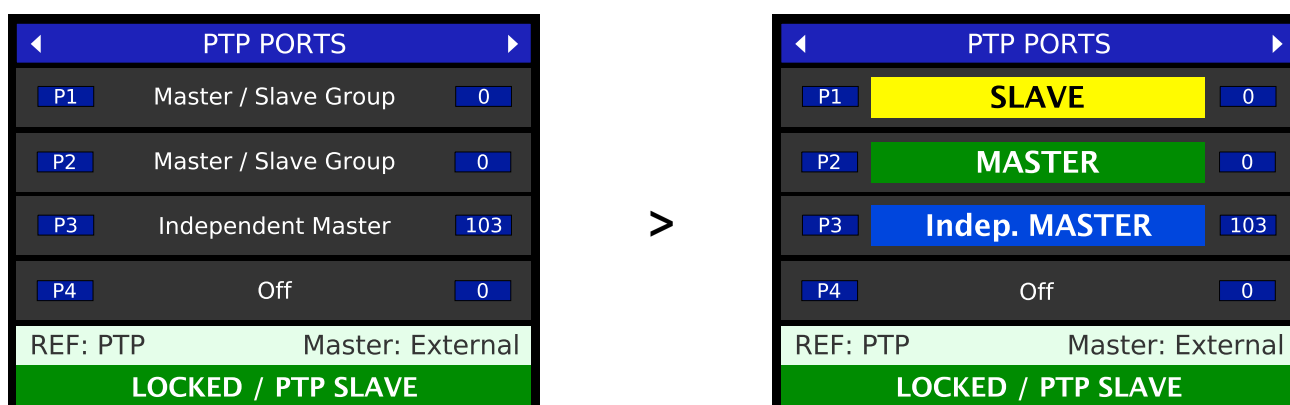

MAIN ROTATION DISPLAY - PTP PORTS Page

The status of each port can be seen on the PTP PORTS page of the main rotation display. The mode of each port is first shown, as entered in menu 5.1. It is displayed in white letters on a dark grey background.

Then the PTP State is displayed, in place of the mode, in bold letters with colors, identifying each state:



13. Output Deviation Indication:

The DXD-16 continuously monitors each output group and looks for timing deviations. The length of each frame is compared to the previous one and, if a deviation is found, it is reported on the OUTPUTS page of the main rotation display by changing the color of the blue boxes on the left side where the output groups are identified.

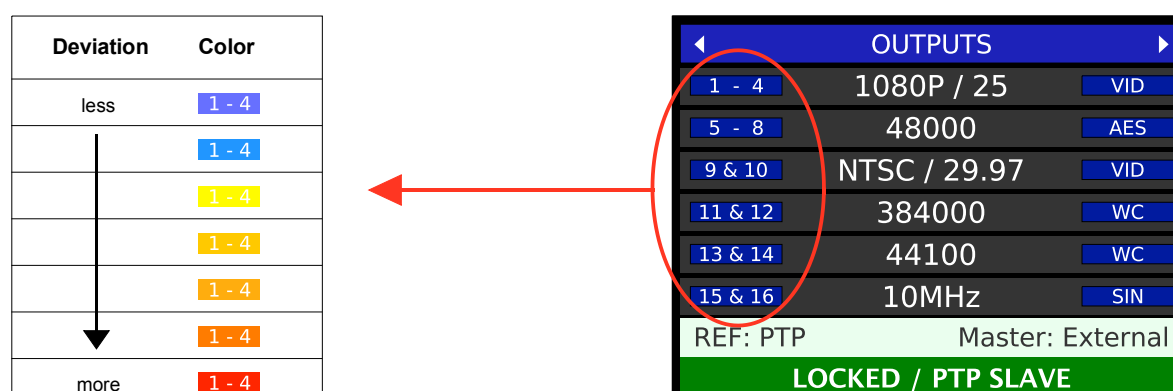

After power up or after selecting a new reference, a lot of jumping around is expected. During a normal synchronization sequence there will mostly be a glitch at the start of the OUTPUT ALIGN sequence, and one more at the end because of the speed change required to get the outputs to the newly desired position. But when a new Grandmaster is selected by the BMCA, while the LOCK status will change during the locking procedure, the outputs may not glitch at all.

14. Positional change from an External PTP Grandmaster

When the DXD is referenced to an external PTP Grandmaster and a disruption or an error causes a positional change in the PTP Grandmaster, the DXD will respond differently based on how it has been set by the operator.

14.1 JUMP TO RELOCK

One of the parameters in menu 1.2 is the PTP Jump Threshold.

When the time difference detected between the external PTP GM and the DXD System Time is above the PTP Jump Threshold value, the DXD will jump to the new time and relock through the normal lock procedure. This will cause disruptions on the output signals but will be the fastest way to be locked with the external PTP GM.

The Jump Threshold can be adjusted in menu 1.2 from 5 msec to 15 sec, or set to 'Never' (default value is 5 msec)..

1.2 SYNC PARAMETERS	
BNC INPUT COLOR FRAMING	Off
BNC INPUT TIME JAM SOURCE:	Off
BNC INPUT TIME JAM RESYNC:	Off
PTP JUMP THRESHOLD:	5 msec

Keep in mind that, with a 15 seconds Jump Threshold, it could take the DXD-16 a long time to slew back in sync. During that time, the lock status will indicate HOLD / PTP SYNC (see ch. 11 above).

15. General Information on PTP

PTP is defined in the IEEE 1588 standard. This chapter covers some general information on PTP. For more details, please refer to the IEEE publication.

15.1 TIME AND PHASE

Precise time information has always been crucial in traditional production and broadcast environments. To keep the different video and audio sources synchronized properly, two different references were typically used, one providing time information (time code), the other phase information (black & burst or tri-level sync for Video and DARS or Word Clock for Audio). With IP networks, PTP provides both Time Of Day and phase information, replacing and/or coexisting with the traditional 'legacy' references.

15.2 WHAT IS PTP?

PTP (Precision Time Protocol) is a method for precisely synchronizing devices over a computer network. On a LAN, PTP can achieve clock accuracy to within a microsecond. Originally designed for network measurements, PTP has been broadly adopted in applications ranging from real-time automations to telecom transmissions and financial transactions.

Published in 2002 by IEEE under the 1588-2002 standard (PTP v1) it was revised in 2008 as 1588-2008 (PTP v2). Version 2 brought several improvements but is not backward compatible with version 1.

15.3 A/V OVER IP APPLICATIONS

PTP has been widely adopted in A/V over IP applications. It is the protocol chosen by AES and SMPTE with PTP profiles included in both the AES67 and ST-2059 standards. The SMPTE ST-2110 suite of standards (digital video over IP with audio, video and ancillary data as separate streams) uses PTP for synchronization as it is based on ST-2059.

Major A/V over IP systems such as Q-LAN, LiveWire, Wheatnet-IP, Ravenna and Dante all use PTP. Although the original Dante used PTP v1, with the release of the Dante Domain Manager version 1.1, a Dante system has the ability to clock to a non-Dante PTP v2 clock.

AVB (Audio Video Bridging) is a set of IEEE standards that facilitate the transport of high performance audio and video on a LAN. One of those standards, IEEE 802.1AS, defines a specific profile of IEEE 1588-2008 with additional timing features called gPTP (Generalized Precision Time Protocol).

15.4 PTP DESCRIPTION

Per IEEE 1588, PTP uses a hierarchical Master-Slave architecture for clock distribution. The primary timing source is called the PTP Grandmaster. Precise timestamps are captured at the Master and Slaves and exchanged to determine the offset between the two and the network latency so that the Slaves can synchronize their internal clocks to the Master's.

With the PTP protocol, two activities continually occur on the network:

- All grandmaster-capable devices negotiate to select a grandmaster.
 - All devices synchronize to the grandmaster.
- **BMCA:** The Grandmaster is elected autonomously without any user interaction. Grandmaster-capable devices broadcast their clock "quality" and other parameters with Announce messages. They each compare the received Announce messages and, independently of the other devices, determine the most suitable grandmaster. This determination is done through the Best Master Clock Algorithm (BMCA), which by design ensures that all clocks reach the same conclusion. This best master clock negotiation continues even after a grandmaster has been selected so that in case the current grandmaster fails another clock can quickly replace it.
 - **SYNC:** Synchronization to the grandmaster is done using a series of messages. Sync messages are broadcasted periodically by the grandmaster and contain timestamps from its internal clock. Slaves read these messages and adjust their internal clocks match exactly the master's. Every update cycle, the slaves calculate corrections for offset and network latency to achieve high precision synchronization.

15.5 SELECTING A GRANDMASTER

An algorithm called the BMCA (Best Master Clock Algorithm) is used to determine which clock will be used as the PTP Grandmaster. As defined in the IEEE 1588 standard, this selection is done autonomously based on the following criteria and in the following order:

- Priority 1
- Clock Class
- Clock Accuracy
- Clock Variance
- Priority 2
- Source Port ID (MAC Address)

Of those fields, two are set manually by the users, Priority 1 and 2, so that preferred masters can be prioritized. It is important to note that, even though through the use of the Priority fields a user can more or less determine which unit will be selected as Grandmaster, it is still the BMCA that makes that determination.

When a Grandmaster has been selected, all other devices on the domain will sync their internal clocks to that of the Grandmaster. If the Grandmaster fails, a new one is selected immediately via the BMCA. If a better suited clock is found, it will become the Grandmaster.

15.6 SYNCHRONIZATION

There are several different PTP messages used during synchronization, sequenced as follows:

1. The grandmaster sends a Sync message with its transmit timestamp (t1), and an optional Follow Up message, in case of the two steps operation, which also includes t1.
2. The slave receives the Sync/Follow Up message, keeps its timestamp (t1) and the Sync message arrival time (t2).
3. The slave sends a Delay Request message back to the grandmaster. This message does not include a timestamp, however the slave keeps the time it sent the Delay Request message (t3).
4. The master receives the Delay Request message and keeps its arrival time (t4). The master then sends back a Delay Response message including t4.

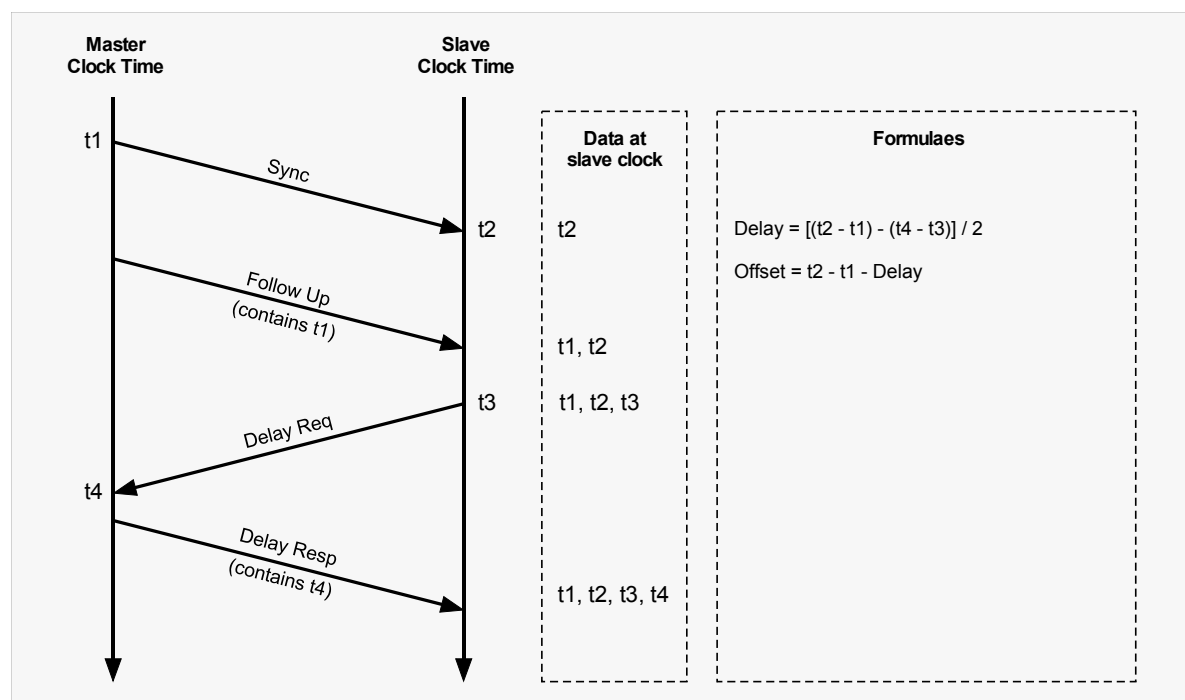

The slave clock now possesses all four timestamps (t1, t2, t3 and t4) that can be used to compute the offset of the slave clock relative to the master, and the propagation time between the two clocks. With this, it can now adjust its clock to match the GM clock.

15.7 DELAY MEASUREMENT MECHANISM

To synchronize clocks, the delay between the clocks must be known. There are two mechanisms to measure the delay called End to End (E2E) and Peer to Peer (P2P).

- The E2E delay mechanism was the only one included in the original IEEE1588-2002. It measures the delay between the master and the slave.

E2E uses the following messages, as described in 1.6. above: Sync, Follow-up (optional), Delay_Req, and Delay_Resp. It can be used with switches or routers that are not 1588 capable.

- The P2P delay mechanism was introduced in IEEE15880-2008. It measures the delay between directly connected ports. Peer-to-peer delay measurement works "locally", from every node to each of its neighbors. For each pair of directly connected ports, each end periodically measures the round-trip network delay by sending a Pdelay_Req message and receiving in response a Pdelay_Resp message. This way all ports learn the delay on their link.

P2P uses messages Pdelay_Req, Pdelay_Resp, and Pdelay_Resp_Follow_Up (optional).

NOTE: An ordinary clock, which has just one port, can be configured for end-to-end or for peer-to-peer; a boundary clock, which can have a single slave port and multiple master ports, can be configured for E2E on some ports and P2P on others.

While a single domain can have both end-to-end and peer-to-peer delay mechanisms running simultaneously, all clocks on a single PTP communication path must use the same method to measure the time delay.

15.8 TYPES OF CLOCKS

IEEE 1588 defines three different types of clocks:

- Ordinary Clock (OC)
- Boundary Clock (BC)
- Transparent Clock (TC)

Ordinary Clocks (OC) are devices with a single port, usually at either end of a network such as A/V equipment, DAW's or speakers. They can be master or slave.

Boundary (BC) and Transparent (TC) Clocks are network devices such as switches or routers.

- A Boundary Clock has more than one port and each port provides access to a separate PTP communication path. It acts as a slave on one of its ports and as a master on the other(s).
- A Transparent Clock passes the PTP messages but adds the time it takes to go through itself (residence-time) in a correction field, making it 'transparent'.

The DXD-16 has 4 separate ports. Each can be set as an Ordinary Clock (independent Master-Only) or as part of a Boundary Clock (menu 5.1). For additional information on Boundary Clock, see 16.1 in the next chapter.

15.9 PTP DOMAINS

A PTP domain is a network (or a portion of a network) within which all of the clocks are in sync. A single network can have multiple PTP domains operating separately, e. g., one set of clocks synchronized to one time scale and another set of clocks synchronized to an other time scale.

15.10 PTP PROFILES

A PTP Profile defines the range and default values of all configurable attributes as well as all required, permitted, or prohibited clock types and options for a specific application area. Profiles can be created by recognized standards associations such as AES or SMPTE. The DXD supports the AES67 Media profile and the SMPTE ST 2059-2 profile. The DXD also support the 1588 default profile.

15.11 EPOCH

PTP uses the concept of an Epoch clock. This is an absolute time value when the clock was set to zero, and the number of 1GHz clock pulses that have occurred since provides the current time, converted with software into year, month, day, hours, minutes and seconds. The Epoch (or zero time) for PTP was set at midnight on the 1st January 1970.

16. Typical PTP Set-Ups

The DXD-16 was designed to be a reliable high precision sync generator as well as a very flexible one. Several features were incorporated in the design with flexibility in mind such as the universal outputs. For PTP, several options are available giving the user many choices. This chapter examines several typical set-ups.

16.1 BOUNDARY CLOCK

IEEE 1588 defines a boundary clock as *a clock that has multiple PTP ports in a domain and maintains the timescale used in the domain. It may serve as the source of time, i.e., be a master clock, and may synchronize to another clock, i.e., be a slave clock.*

In the latter case, a boundary clock (BC) will have 1 port in a slave state receiving time from the Grandmaster and the other ports in a master state distributing time to downstream slaves, thus creating a boundary between the Grandmaster and the slaves connected to the BC.

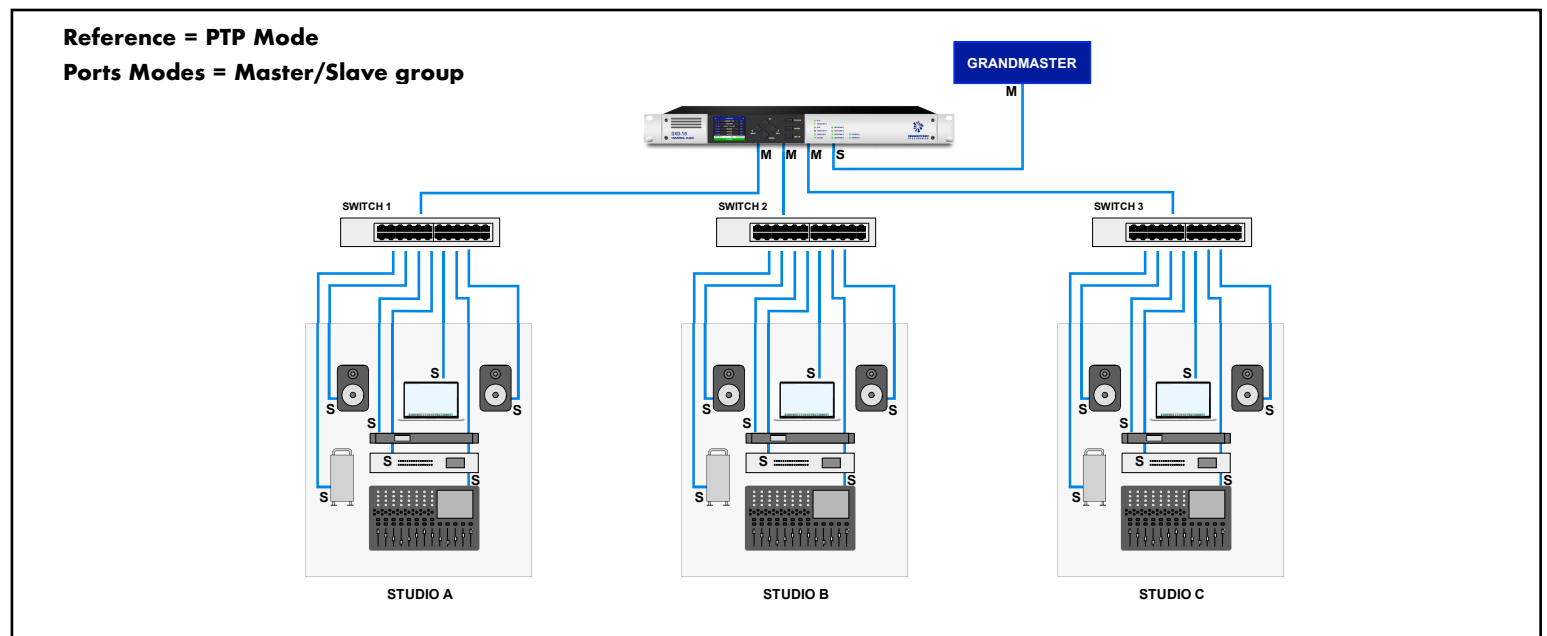

To set the DXD-16 as a Boundary Clock, set the Reference to 'PTP Mode' and the participating ports to 'Master / Slave group'.

In this example, Studios A, B & C do not communicate with the Grandmaster but rather with the DXD-16 ports.

- The PTP PORTS Main Rotation display will show the states of **SLAVE** and **MASTER** (see 6.1.2).

BOUNDARY CLOCK and BMCA

Per IEEE 1588 v2, as a Boundary Clock, the DXD-16 uses a 2-step process for the BMCA. First, each port of the DXD-16 will look at the network attached to it and decide which unit on that network is the best master clock. These results are then fed to the central DXD-16 clock to determine which of these or the DXD-16, is the best clock overall and becomes the Grandmaster.

When an external clock is selected as the Grandmaster, the port connected to it will switch to Slave state while all other ports will revert to Master state. The Master ports will assume the characteristics of the Grandmaster (priority, clock quality, ...) and announce that information so all units connected to the other ports will arrive at the same BMCA result and switch to Slave state. This process could take several seconds or longer.

On the other hand, if the DXD-16 itself is selected as the best clock, it becomes the Grandmaster and all 4 ports will have the state of Grandmaster (or in some cases PASSIVE - see chapter 12).

16.2 4-MASTER PORTS ON A SINGLE DOMAIN WITH GPS REFERENCE

With all ports in 'Master / Slave group' mode, selecting GPS as the Reference will place all the ports in a 'Master-only' mode.

- ▶ The PTP PORTS Main Rotation display will show the state of **MASTER** (see 6.1.2).

Alternatively, the reference could be 'PTP Mode' and the GPS set as 'Local Ref When GM' (menu 1.1). When the DXD-16 is selected as the Grandmaster by the BMCA, all ports are Grandmasters.

- ▶ The PTP PORTS Main Rotation display will show the state of **GRANDMASTER** (see 6.1.2).

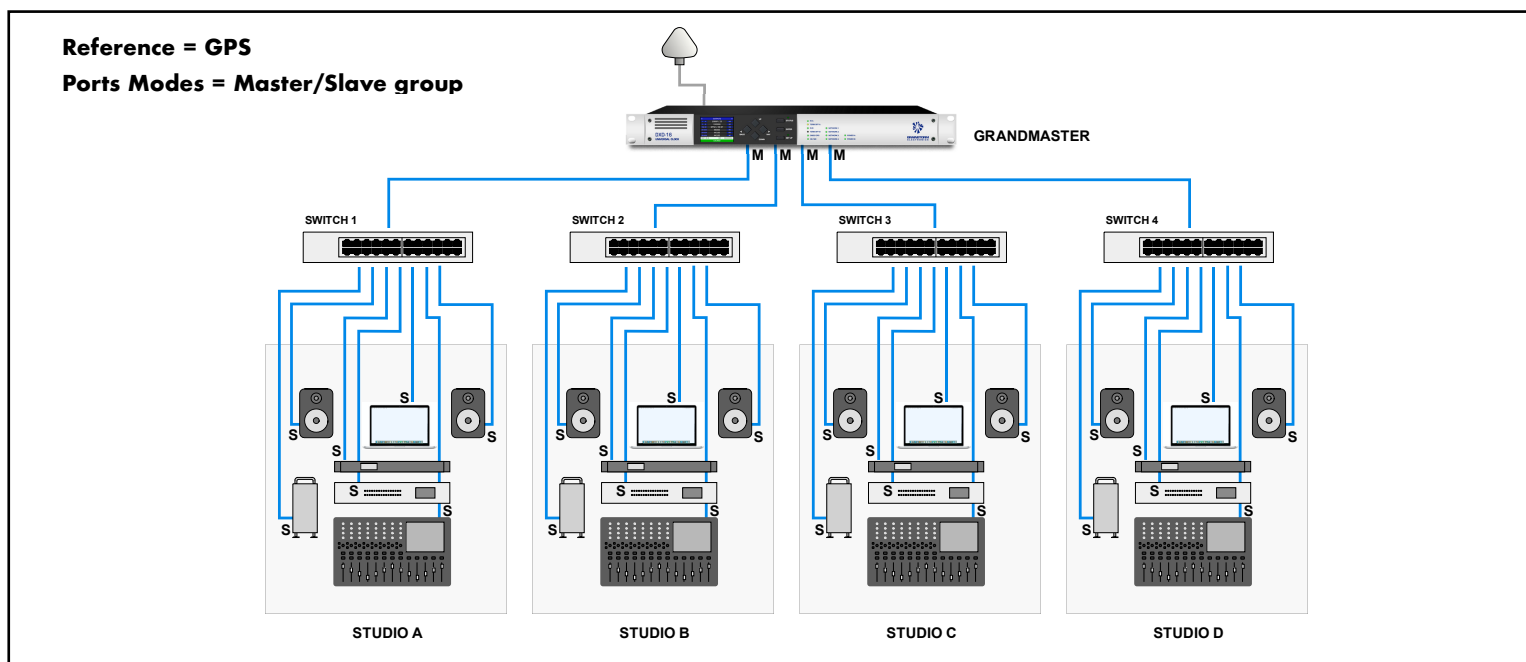

4 Master-only ports on a single domain with GPS reference

NOTE: per IEEE 1588, if multiple ports of a boundary clock communicate to the same communication path (i.e. "see" each other), the boundary clock shall place all of the involved ports in the PASSIVE state, except the port with the lowest portNumber. As this rule also applies to the DXD 'group' setting, if the different segments shown on the diagrams are connected via a main switch, some of the ports in the group may 'see' each other and therefore be placed in the PASSIVE state as required by IEEE 1588.

16.3 4-MASTER PORTS ON SEPARATE DOMAINS WITH GPS REFERENCE

Another way to have 4 master ports would be to set all ports to 'Independent Master'. In this case, the Reference selection would have no effect on the Ports Mode so GPS could be set as the reference for a scenario very similar to the one above. The difference however would be that here all ports would be on a different PTP domain.

- ▶ The PTP PORTS Main Rotation display will show the state of **Indep. MASTER** (see 6.1.2).

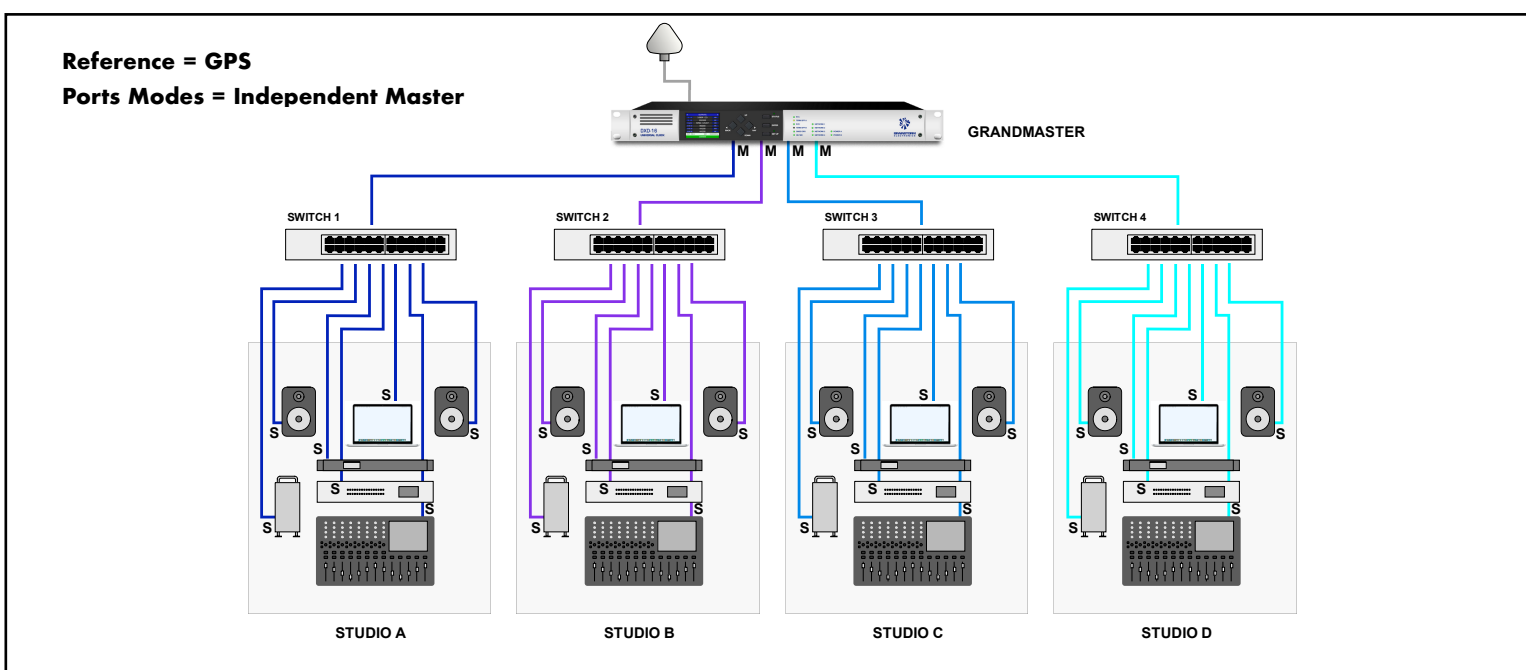

4 Independent Master ports on 4 separate domains with GPS Reference

16.4 HYBRID SYNC GENERATOR ACCEPTING MULTIPLE REFERENCES

One of the original concept behind the DXD-16 was to generate 'legacy' sync and PTP sync simultaneously so that all equipment could be kept perfectly synchronized. But, for added flexibility, the DXD-16 can also be set up to lock to any 'legacy' sync or to PTP as illustrated below. These choices are available in the Reference menu.

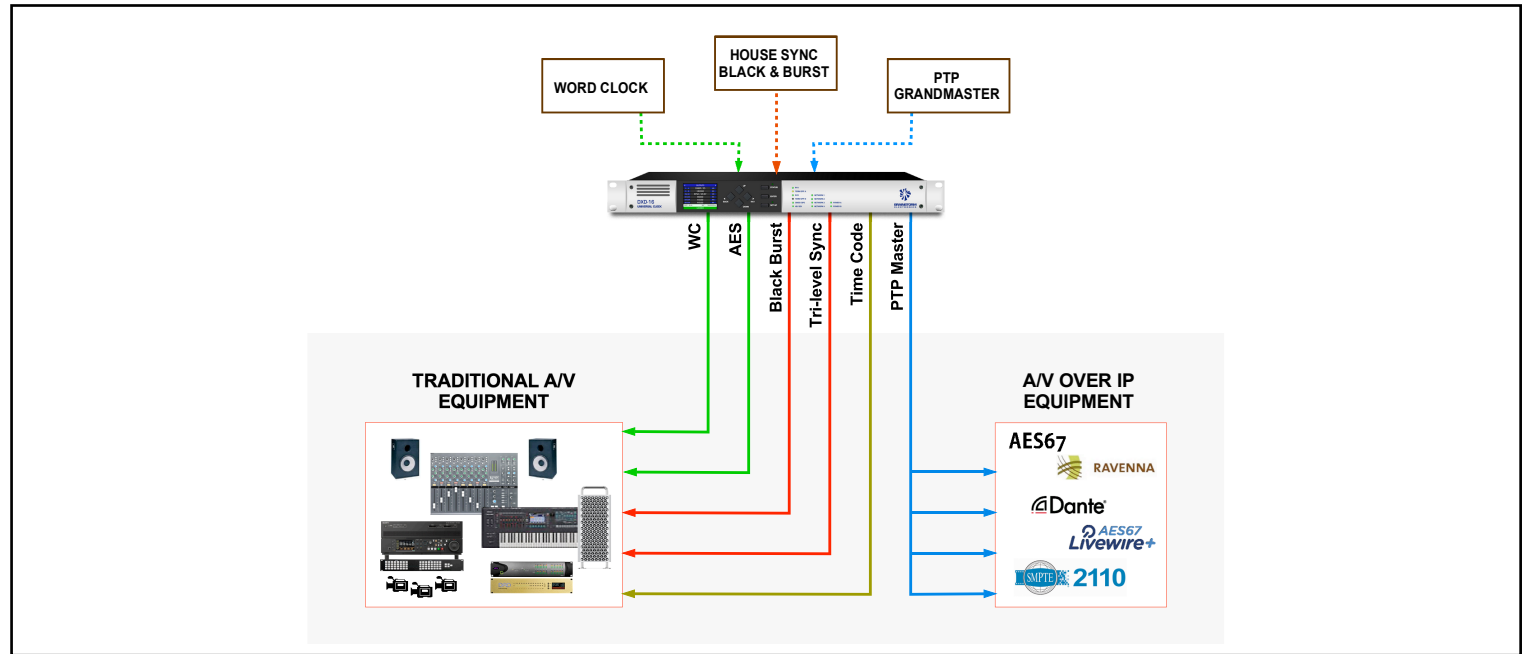

To reference an IP island to black burst (traditional infrastructure), set the DXD-16 as follows:

- Reference = INPUT A/Vid
- Port Mode = Independent Master or Master / Slave group
- IP Island locks to a Master port

To reference a legacy island to PTP (IP infrastructure), set the DXD-16 as follows:

- Reference = PTP Mode
- Port Mode = Master / Slave group
- Legacy Island locks to BNC outputs (WC, AES, Video Sync, as required)

16.5 PTP PRIMARY AND SECONDARY NETWORKS

In this example, 'PTP Mode' is the selected reference (menu 1.1) and ports 1, 2 & 3 are set to 'Master/Slave group' (menu 5.1) so the DXD-16 acts as a Boundary Clock. The networks connected to ports 1 & 2 (Master ports) are the primary and a secondary, the latter being used for redundancy. The BMCA will determine which port becomes the primary master vs. a passive master on the secondary port. Port 3 of the Boundary Clock is in a Slave state locked to the Grandmaster. In this example, port 4 is used for non-PTP duties, engineering network.

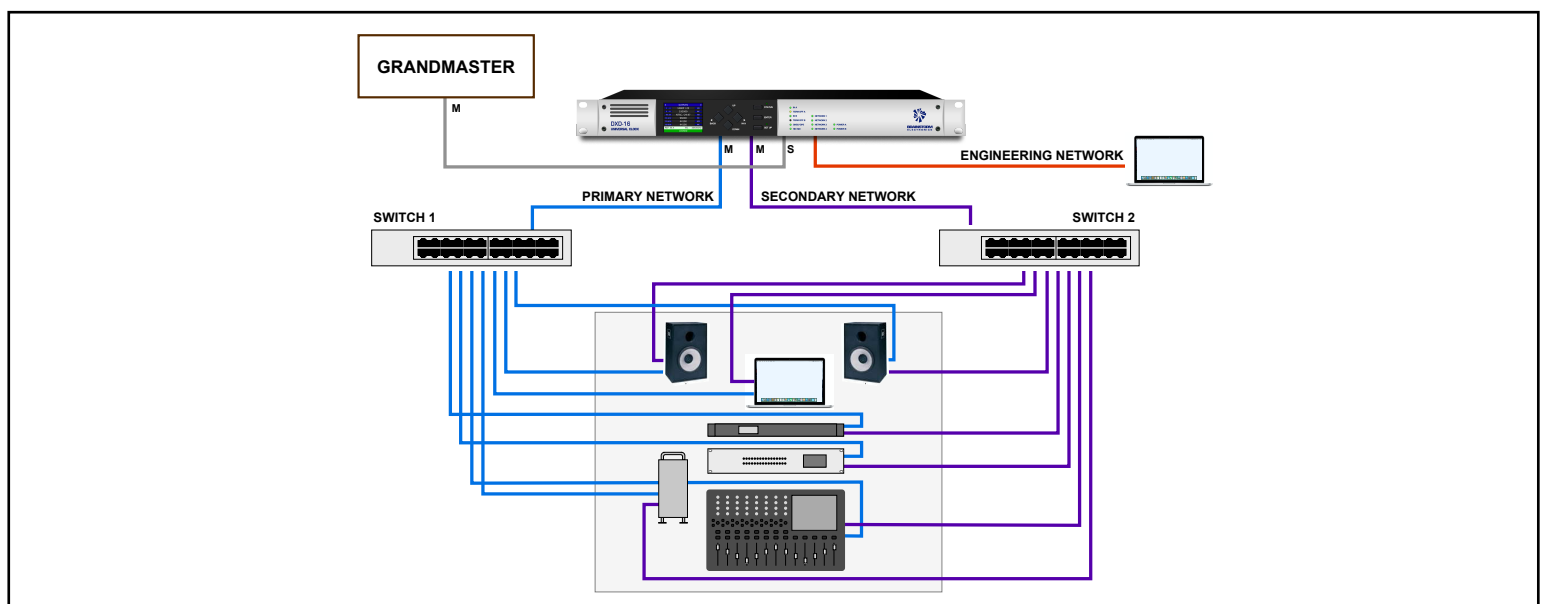

Another possibility is to set the 2 master ports to 'Independent Master' instead and the slave port to 'Master/Slave group'. This would allow to set the priorities of the 2 master ports to determine the BMCA outcome. In this case, the primary and secondary networks would be on a separate PTP domain. There would only be 1 port in the 'Master/Slave group' and with 'PTP Mode' as the reference selection, the DXD-16 would lock to the Grandmaster through that port.

16.6 DISTRIBUTED PTP VS. INDIVIDUAL GRANDMASTERS WITH GNSS

In this scenario, DXD-16's are installed in several studios. In order to keep them in sync, 2 different options are available: the first illustration shows distributed PTP where all the DXD-16's are PTP slaves to an external Grandmaster; in the second illustration, the DXD-16's are all Grandmaster for their networks and each is locked to GNSS. This second solution is particularly useful when distances between studios are long and certainly for remote trucks.

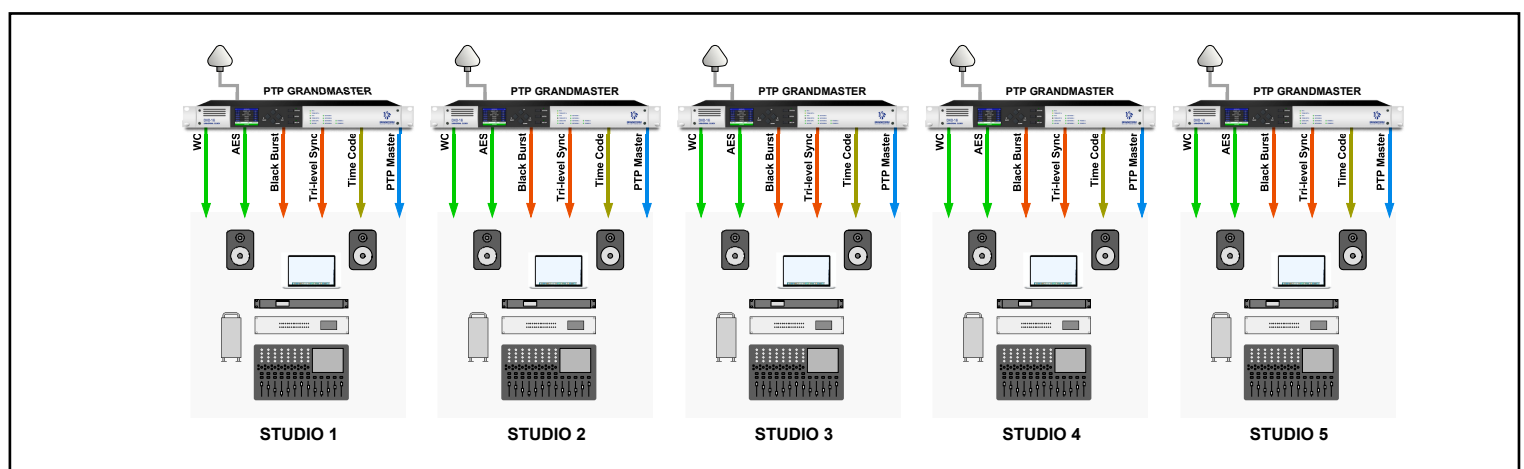
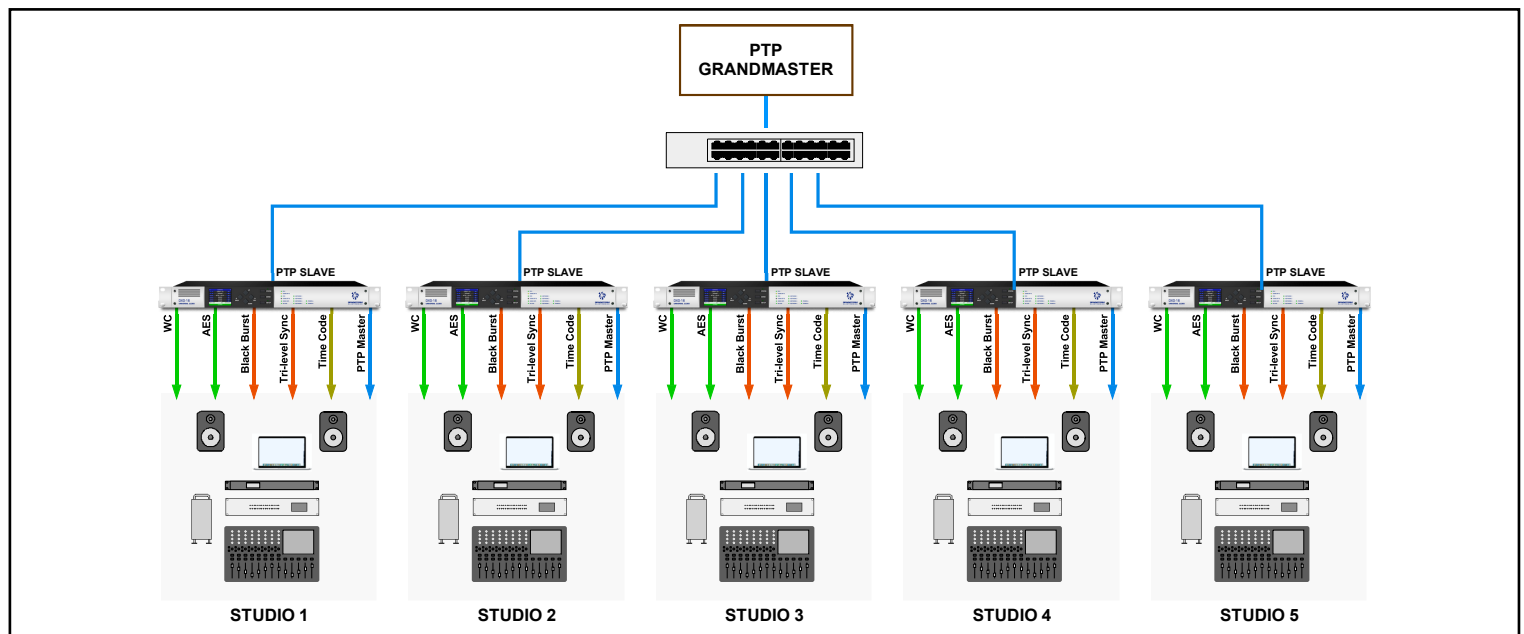

IMPORTANT SECURITY NOTE:

THE DXD-16 HAS 4 ETHERNET PORTS BUT IS NOT A SWITCH. **NO DATA CAN EVER BE TRANSMITTED FROM ONE PORT TO ANOTHER.** THE DXD-16 IS DESIGNED TO SYNCHRONIZE MULTIPLE NETWORKS WITHOUT HAVING TO WORRY ABOUT SENSITIVE DATA EVER BEING TRANSFERRED FROM ONE NETWORK TO ANOTHER THROUGH THE DXD-16

17. Guidelines for configuring PTP (Precision Time Protocol)

Only a few years ago, setting up a network was not a task most audio or video engineers were concerned with. This was the responsibility of the IT department. Nowadays, it has become an important part of more and more installations and, as we move towards A/V over IP, careful advance planning of the network and proper configuration is necessary, demanding a new set of skills.

Although configuring an A/V network includes many settings that do not concern the DXD-16, PTP is a complex standard and a good understanding of network technology is required. The best source of information for PTP is the IEEE 1588 standard itself available here: <https://standards.ieee.org/standard/1588-2019.html>. There are also many publications available from different organizations such as SMPTE and AES with best practices recommendations.

PTP's role is to synchronize the real-time clocks of the different nodes on a network but it does not make the network itself synchronous. The traditional master/slave architecture is also very different when dealing with PTP thanks to the BMCA.

The list below only includes some very basic PTP requirements and recommendations and is not meant to be a comprehensive check list.

17.1 REQUIREMENTS

- **PTP Domain:** Devices that need to be synchronized together via PTP must be part of the same domain. Be sure the PTP domain is set properly on your DXD as messages with any other domain number will be ignored. (menus 5.2 and, if required, 5.3.3, 5.4.3, 5.5.3, 5.6.3).
- **Ports Timing:** per IEEE 1588, all devices on a PTP domain must have the same value set for these ports timing:
 - Announce Interval
 - Announce Receipt Timeout
 (menus 5.3.2, 5.4.2, 5.5.2, 5.6.2).
- **Delay Mechanism:** Two different delay mechanisms are available: E2E and P2P. End-to End mechanism is more versatile because it can handle ordinary switches and routers but in large networks with lots of slaves, the master clock and the network could be heavily burdened with large amount of delay request and response messages. With Peer-to-Peer mechanism, delay is established between neighbors only.
 - P2P requires all of the devices to be PTP-aware as ordinary switches will not respond to peer-delay messages.
 - All the 1588 nodes on the same messaging path are required to use the same delay mechanism.
 (menus 5.3.1, 5.4.1, 5.5.1, 5.6.1).

17.2 RECOMMENDATIONS

- **DXD-16 Ports:** Ports 1 & 2 on the DXD-16 have a slightly higher PTP processing bandwidth compared to ports 3 & 4. When a large number of devices are to be connected to the DXD-16, ports 1 & 2 should be preferred. Nevertheless, at the time of writing, ports 3 & 4 have been observed to support over 180 slave devices individually.
- **PTP Profile:** It is recommended to use the same profile for all units in any particular domain. Failure to do so can lead to unexpected results. (menus 5.3.1, 5.4.1, 5.5.1, 5.6.1).
- **Priority Fields:** If the DXD-16 is your preferred master clock, the simplest way to make it the Grandmaster is to set the Priority 1 field low enough to win the BMCA. However, it is also recommended that all candidate GMs would have the same Priority 1 value to avoid causing hierarchy issues as the Priority 1 field overrides any clock quality changes in the GM. (menus 5.2 and, if required, 5.3.3, 5.4.3, 5.5.3, 5.6.3).

Keep in mind that, with PTP, the BMCA always determines which device (or which port) becomes Grandmaster. As conditions change (loss of GPS for example), another Grandmaster could be selected, changing the state of the DXD-16 ports. But this would only be true if, as recommended above, all candidate GMs would have the same Priority 1 value.

17.3 NETWORKING HARDWARE

- **PTP-aware:** PTP is implemented in some networking hardware often referred to as 'PTP-aware', meaning either as an IEEE 1588 "Transparent Clock" or "Boundary Clock". This includes switches and routers. Transparent Clocks and Boundary Clocks are designed to improve accuracy particularly in large and busy environments.
- **Non-PTP-aware and QoS:** The DXD-16 has been observed to perform very well with standard non-PTP switches. It adheres to the IEEE 1588 2008 Annex D recommendation that, for PTP event messages, the value of the differentiated service (DS) field in the Type of Service (ToS) field is set to the highest traffic class selector codepoint available, which in this case is the DSCP value "High Priority / Expedited Forwarding (EF)". This means that, with a switch properly configured for Quality-of-Service (QoS), PTP traffic from the DXD-16 will be prioritized over other traffic.
- **Router/DHCP:** It is always required to have a router visible to the DXD on the network when using DHCP. Without the router (and the DHCP server), fixed IP addresses must be used and set manually in menus 4.
- **IGMP - internet Group Management Protocol:** The DXD-16 supports IGMPv2. On larger networks, a router is required to manage multicast group membership. Switches that support IGMP snooping are also recommended.

18. Firmware Updates

Firmware updates and remote control are done via Ethernet, from port #4 only. Connect port # 4 of your DXD-16 to your network and point your browser to the IP address of your DXD-16 port 4. A simple firmware loader page will appear.

18.1 FIRMWARE LOADER PAGE

Click on the [BROWSE] button and select the firmware file on your hard disk. Typically, this would be DXD16FS_<version>.upld. Then click [UPLOAD]. The normal programming sequence will follow.

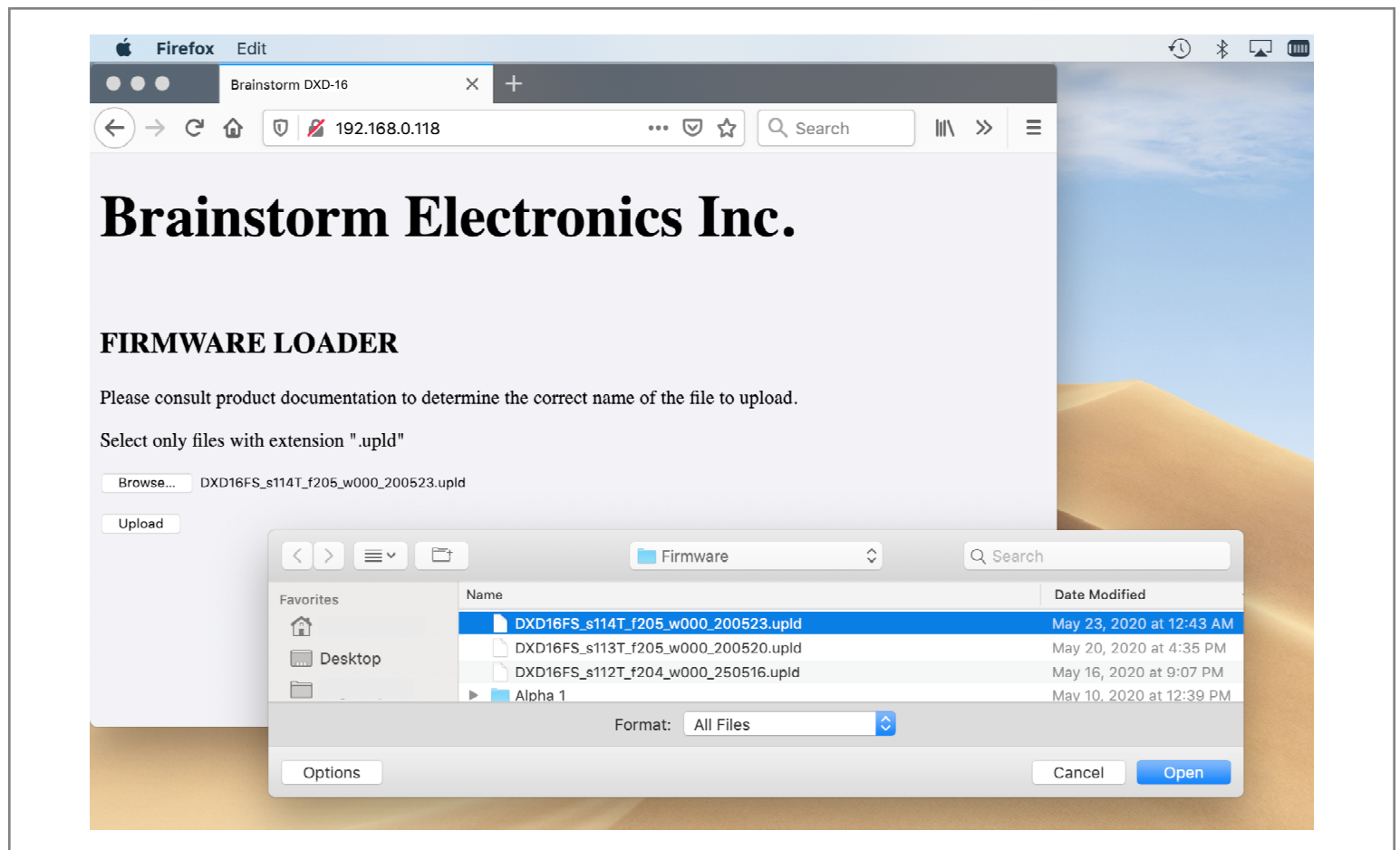

NOTE: some browsers such as Safari will not let you select the .upld file as it is not a recognized format. When using Firefox, after clicking on [BROWSE], a window appears that will let you navigate to the proper folder. On the bottom left of that window click on the <Options> button. Under FORMAT, select 'all files' so you can select the .upld file.

18.2 PROGRAMMING SEQUENCE

There are 3 steps in the normal programming sequence:

- UPLOAD
- VERIFY
- PROGRAM

The first 2 steps happen very quickly and may not be noticeable. The 3rd step will take a little longer and a window with a progress bar will appear on the front panel display.

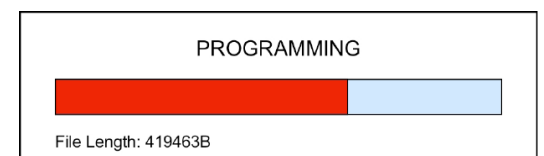

After the programming is completed, rebooting is required. A message appears on the display to reboot the unit.

18.3 FIRMWARE FILE NAMING CONVENTION

A DXD-16 firmware release includes 3 different sections:

- software,
- logic (FPGA),
- webpage.

These can be seen in the UNIT INFORMATION Status page, as described in 6.2.1.

Although the 'software' number is used to name a release (rev 1.00 for example), the actual file name includes all 3: dxd16fs_s108_f104_w009_191209.upld, where fs= File System, s=software, f=FPGA logic and w=webpage, followed by the date.

18.4 UPLOADER

The Uploader is a fall-back web page that allows you to restore your DXD-16 in case of a catastrophic programming failure. This page is located in a different area of the Flash Memory, unaltered by regular firmware updates. These failures are very rare and should not happen.

To enter the UPLOADER mode: Hold down the [DOWN] and [SET UP] keys simultaneously while powering up.



All of the LEDs will flash momentarily to notify you that the keys have been recognized. The following message will appear in the display:

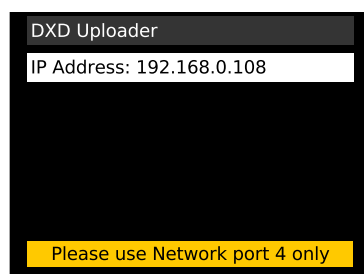

From the Uploader mode you can adjust the IP addresses and the DHCP mode in the usual way. Press the [SET UP] key to go into the SET UP mode. Only 3 menus are available while in the Uploader mode: Network, Brightness and Reboot.

Note that settings from the Uploader are not saved, only the main application will do that.

Point your browser to the IP address of your DXD-16. A page similar to the regular Firmware Loader page described above will appear.

To restore your unit, use the BROWSE button to locate the firmware file on your hard disk (.upld) and click UPLOAD. The normal programming sequence described in 18.2 will follow.

19. Remote Control

The DXD-16 is designed to be accessed remotely via a web browser. Web pages similar to the Firmware Update page give access to all parameters and settings of the DXD-16 so they can be monitored and modified .

The current firmware, version 2.1, does not include those web pages yet. Please check for the Remote Control function in an upcoming firmware release.

20. GPIO / LTC connector (DB-25)

The DXD-16 has a DB-25 connector on the rear panel (for diagram and wiring instructions, go to Appendix E). The functions of this connector are GPIO's, 1PPS Out and LTC Outs.

20.1 GPIO

The DXD-16 has 3 General Purpose Inputs (GPI) and 3 General Purpose Outputs (GPO). Menus 9.1 and 9.2 let you set the functions assigned to each input and output. For wiring instructions, see Appendix E.

20.2 1PPS/GPO

A 4th Output (5V CMOS) has 2 functions, as set in menu 9.2. If not used as a GPO, it outputs a 1PPS (high pulse).

20.3 LTC

2 balanced LTC outputs (Longitudinal Time Code) are also included. The DXD/LTC option is required for this function. For more information, please refer to the DXD/LTC manual. Note that the DXD/LTC option is not available yet as of version 2.00. Please check with us in the future.

The DB-25 connector includes a few reserved pins as shown in Appendix E.

21. Non-Volatile Storage

The DXD-16 has non-volatile memory holding the current settings. This includes all DXD-16 settings such as PTP, network and time settings, rate and reference selections as well as output assignments. This memory is continuously updated so that, when the unit is turned on, it is in the same condition as it was when powered down.

NOTE: You should wait approximately 2 seconds after a change was entered before powering down, to allow for the flash memory to be updated.

22. Power

Two different power sources can be connected to the DXD-16: (A) 100-240 VAC and (B) 12 VDC. Either one can be used to power the unit. Two front panel LED's indicate if power is connected to the corresponding connector, A or B.

22.1 POWER FAILURE W/ DUAL POWER SOURCES

When two power sources are connected and one fails, the DXD-16 will continue to operate without interruption. The corresponding front panel LED will flash to indicate a failure.

Note that, with both power sources connected, if the 12VDC supply fails, a new one can be connected in place of the faulty one without powering down the unit. The front panel LED will stop flashing when proper power is applied.

23. Troubleshooting - Error / Warning Messages

There are several types of messages the DXD-16 will display in case of problems. Two different colors are used: Red for errors; Orange for warnings.

23.1 RATE INVALID WARNING

When selecting a BNC input as the reference source, if the incoming signal does not correspond to the signal defined in menu 2 (BNC Input Set Up), this warning message will appear. A red REF ERROR indication will also appear on the Ref line at the bottom of the main rotation display and the lock status bar will indicated UNLOCKED.

- **Make sure the BNC Input is set properly in menu 2.**

23.2 PRIMARY AND ALTERNATE REFERENCES INCOMPATIBLE

This message appears when BNC Input B is set as an alternate reference and is not the same as BNC Input A.

- **Make sure BNC Input B is set as BNC Input A (menu 2.2).**

23.3 OFFSPEED REFERENCE

When 'SET' is selected in the BNC INPUT SET UP menu and the reference is detected to be off speed by more than 0.075%, the Lock bar at the bottom of the display indicates the message 'OFFSPEED'. Under an 'Offspeed' condition, the DXD-16 will generate a rate different that what is announced. The difference of the generated rate will be the same percentage as the one of the reference input (see chapter 9).

- **Make sure the rate value entered in menu 2 (with SET selected) is the rate of the reference.**

23.4 PTP 'NO PORT' WARNING

When PTP Mode is selected as the reference a warning message will appear when no port has been set to Master / Slave Group.

This message indicates 3 possible causes:

- Port Mode not assigned
- Missing IP address
- Network disconnected.

If a port has been set to Master/Slave Group yet the warning message appears, it would indicate that the PTP initialization request has not been granted. This could happen because the IP address hasn't been set properly, possibly due to a DHCP error.

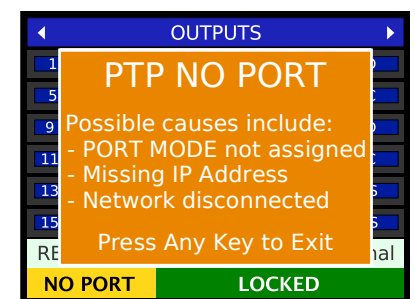

- **Make sure at least 1 port has been set to Master/Slave Group (menu 5.1)**
- **Make sure the port has an IP address (menu 4)**

23.5 PORT IN PASSIVE STATE

Per IEEE 1588, a port in Passive state is not the master on the path nor does it synchronize to a master.

- Independent Master: In a case where the port was set to Independent Master, if another unit is selected by the BMCA as the master for that domain, the port will switch to Passive.
- **If the port must be the Master on that domain, check the Priority settings (menu 5.x.3)**
 - Master/Slave Group: In a case where the port is set to Master/Slave Group (Boundary Clock), a Master port will switch to Passive if it communicates with another Master port of the DXD-16 (for more on the Passive state, see 7.5.1).
- **Make sure the 2 ports do not communicate**

23.6 TIME JAM TIME OUT

An error message will appear when the conditions for a Time Jam are not met.

1. Menu 1.1: Reference must be Input A or Input B.
2. Menu 1.2: A valid source must be selected as the BNC INPUT TIME JAM SOURCE.
3. Menu 5.1: If a PTP port was selected, TIME JAM (BNC INPUT) will automatically show on the corresponding PTP port line in blue (blue = status information). The words [Time Jam] will also appear on the REFERENCE line at the bottom of the main rotation pages.
4. Menu 5: If PTP was selected, the PTP domain of the Time Jam Port must be set to the same domain as the external PTP Grandmaster source. Time Jam Port domains are set in different menus for each port. P1: 5.3.4/ P2: 5.4.4/ P3: 5.5.4/ P4: 5.6.4.

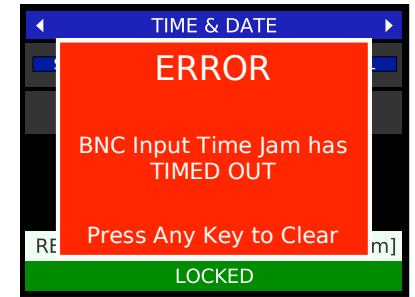

- **Make sure the menus listed above are set properly.**

23.7 ALL PTP PORTS ARE IN PASSIVE STATE

If the DXD-16 reference is an external source (BNC Input A, BNC Input B or GPS), ports set to Master/Slave Group automatically become Master-Only. If Priority 1 is not set low enough and another unit becomes the PTP Grandmaster, then all those ports will become PASSIVE. For Master/Slave Group, this would be set in Menu 5.2.

A port set as an independent master can only be a PTP Master no matter what reference is selected. For that port, Priority 1 needs to be set in different menus. P1: 5.3.3/ P2: 5.4.3/ P3: 5.5.3/ P4: 5.6.3.

- **Make sure Priority 1 is set low enough for the DXD-16 to become the PTP Grandmaster.**

24. Appendix

24.1 APPENDIX A: VIDEO INPUT FORMATS

The following table lists all the video formats recognized by the DXD-16 as reference:

525i/29.97 NTSC	720p/23.976	1080i/25	1080p/23.976
525i/30	720p/24	1080i/25 295M	1080p/24
625i/23.976 PAL-	720p/25	1080i/29.97	1080p/25
625i/24 PAL-	720p/29.97	1080i/30	1080p/29.97
625i/25 PAL	720p/30	1080sF/23.976	1080p/30
	720p/50	1080sF/24	1080p/50
	720p/59.94	1080sF/25	1080p/50 295M
	720p/60	1080sF/29.97	1080p/59.94
		1080sF/30	1080p/60

"PAL-" stands for slow PAL.

24.2 APPENDIX B: AUDIO BASE RATES

The DXD-16 has 2 different audio base rates, defined in menus 3.7 and 3.8. Those are used to generate the audio signals, WC and AES.

The table below shows the different rates available, based on 3 different sampling frequencies: 32KHz, 44.1KHz and 48KHz. 44.1KHz has the -0.1% coefficient option while 48KHz has 7 variants (see 24.3).

	Coefficient	Base Rate	x 2	x 4	x 8
32000	none	32,000.000 Hz	-	-	-
44100	-0.1%	44,055.900 Hz	88,112 Hz	176,224 Hz	352,447 Hz
44100	none	44,100.000 Hz	88,200 Hz	176,400 Hz	352,800 Hz
48000	-4.1%	46,033.920 Hz	92,068 Hz	184,136 Hz	368,271 Hz
48000	-4%	46,080.000 Hz	92,160 Hz	184,320 Hz	368,640 Hz
48000	-0.1%	47,952.000 Hz	95,904 Hz	191,808 Hz	383,616 Hz
48000	none	48,000.000 Hz	96,000 Hz	192,000 Hz	384,000 Hz
48000	0.1%	48,048.000 Hz	96,096 Hz	192,192 Hz	384,384 Hz
48000	4.2%	49,999.680 Hz	99,999 Hz	199,999 Hz	399,997 Hz
48000	4.3%	50,050.032 Hz	100,100 Hz	200,200 Hz	400,400 Hz

24.3 APPENDIX C: PULLED RATES

The DXD-16 provides several 'pulled' rates. Different pull coefficients exist because of the different video rates: 30fps, 29,97fps, 25 fps, 24fps and 23,98fps.

- - **0.1%**: The original rate of NTSC Black & White video was 30fps. When color was introduced, the rate had to be slowed down slightly for technical reasons and a rate of 29.97fps was chosen, or 1/10 of a percent slower (-0.10%).
- - **4%**: The rate of PAL is 25 fps while the rate of film is 24fps. That is a 4% difference ($25 \times 96\% = 24$).

The DXD-16 provides 0.1% and 4% pulled down and pulled up rates, and a combination of both coefficients down and up as well for multiples of 48KHz. Only -0.1% is provided for multiples of 41.1KHz.

24.4 APPENDIX D: MULTIPLIER RATES

With the 2 base rates properly set, multiples of those can be generated. Below is a table showing the different audio rates that can be generated by the DXD-16.

Basic Sample Rate	Pull coefficient	Actual Rate	Labeled as
32000	0.000%	32,000.000 Hz	32000
44100	-0.100%	44,055.900 Hz	44100 - 0.1%
44100	0.000%	44,100.000 Hz	44100
48000	-4.096%	46,033.920 Hz	48000 - 4.1%
48000	-4.000%	46,080.000 Hz	48000 - 4.0%
48000	-0.100%	47,952.000 Hz	48000 - 0.1%
48000	0.000%	48,000.000 Hz	48000
48000	0.100%	48,048.000 Hz	48000 + 0.1%
48000	4.166%	49,999.680 Hz	48000 + 4.2%
48000	4.271%	50,050.032 Hz	48000 + 4.3%

24.5 APPENDIX E: DB-25 PINOUT & GPIO CIRCUITRY

The DB-25 connector provides 2 balanced time code outputs, 3 General Purpose Inputs (GPI) and 4 General Purpose Outputs (GPO). Time Code outputs are only available with the LTC option installed (see the DXD/LTC manual).

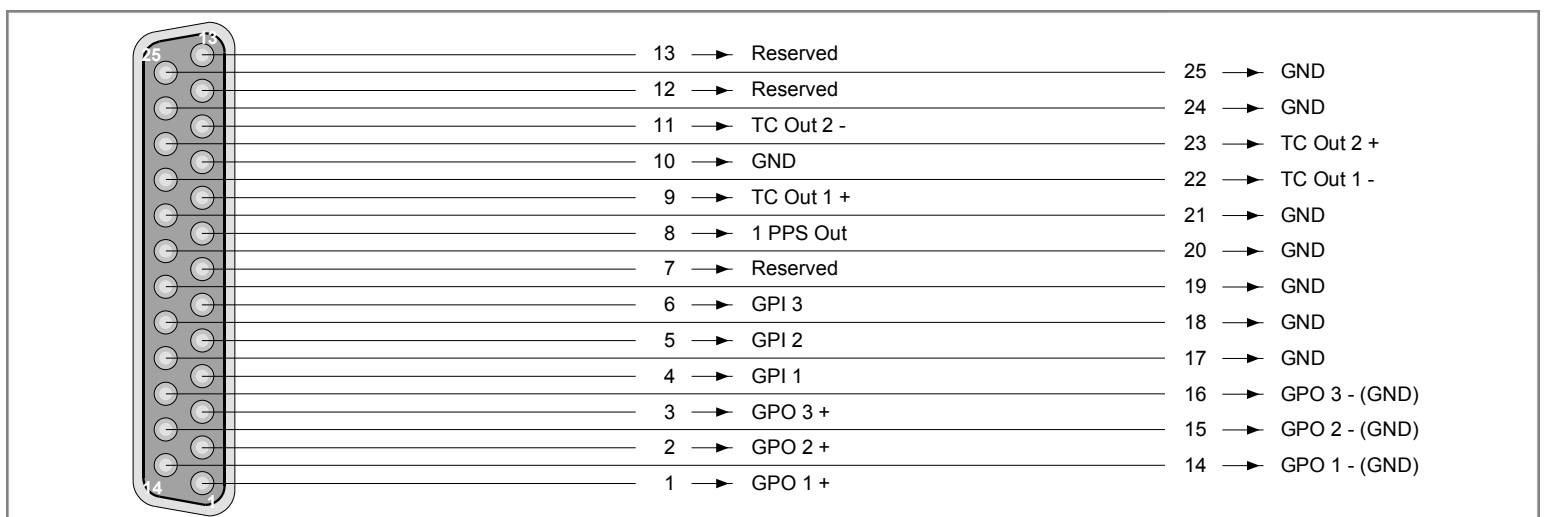

The 3 General Purpose Inputs (GPI) are high impedance inputs pulled up to 5VDC that expect an active low inputs (such as a switch closure to ground). The diagrams below show the circuitry for each pin.

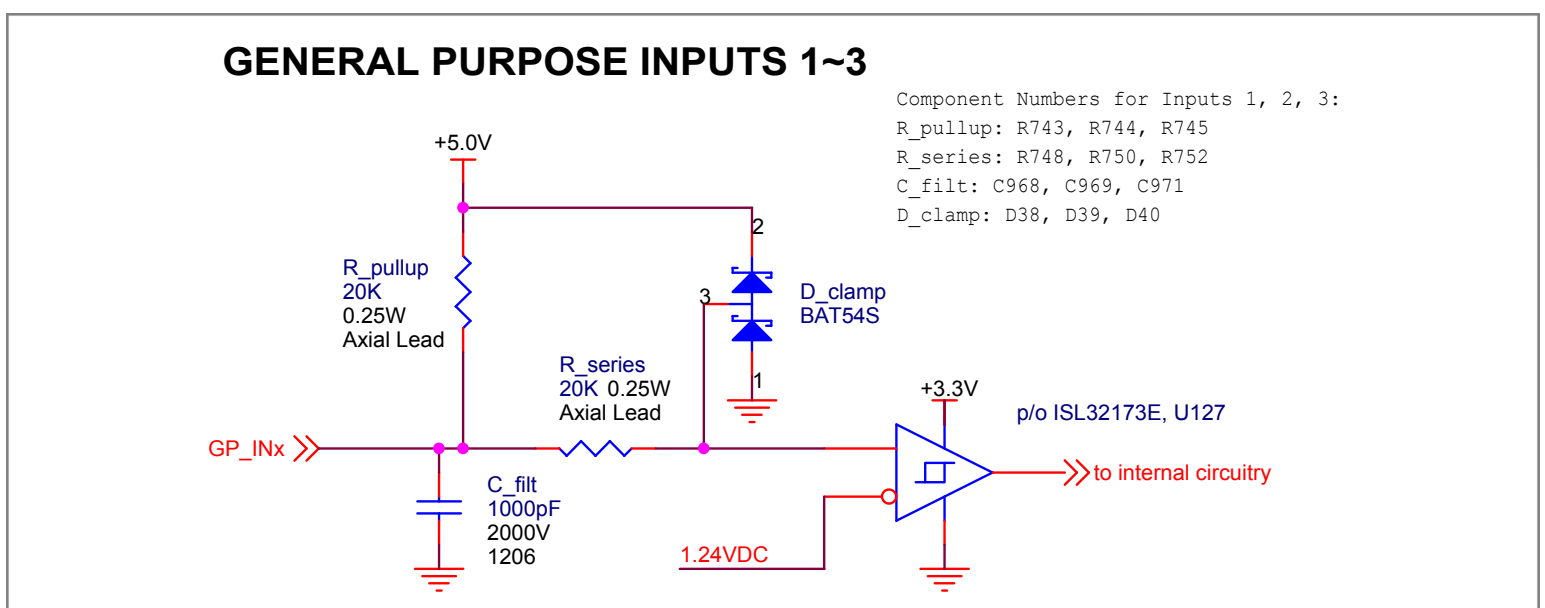

The first 3 General Purpose Outputs (GPO) are open-drain outputs pulled up internally to 5VDC.

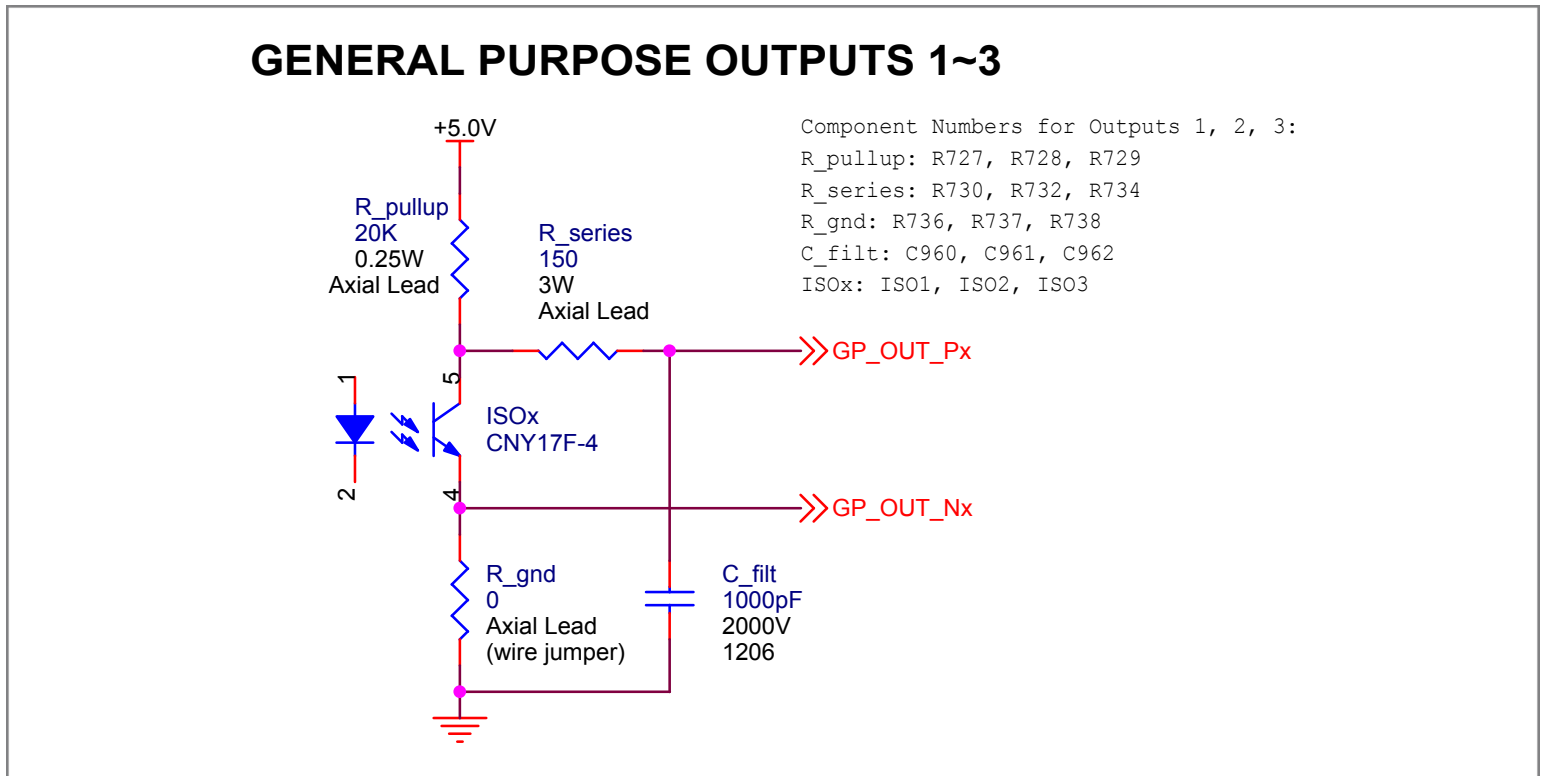

The fourth output is strictly 5V CMOS. When not used as a GPO, it is a 1 PPS output (see menu 9.2).

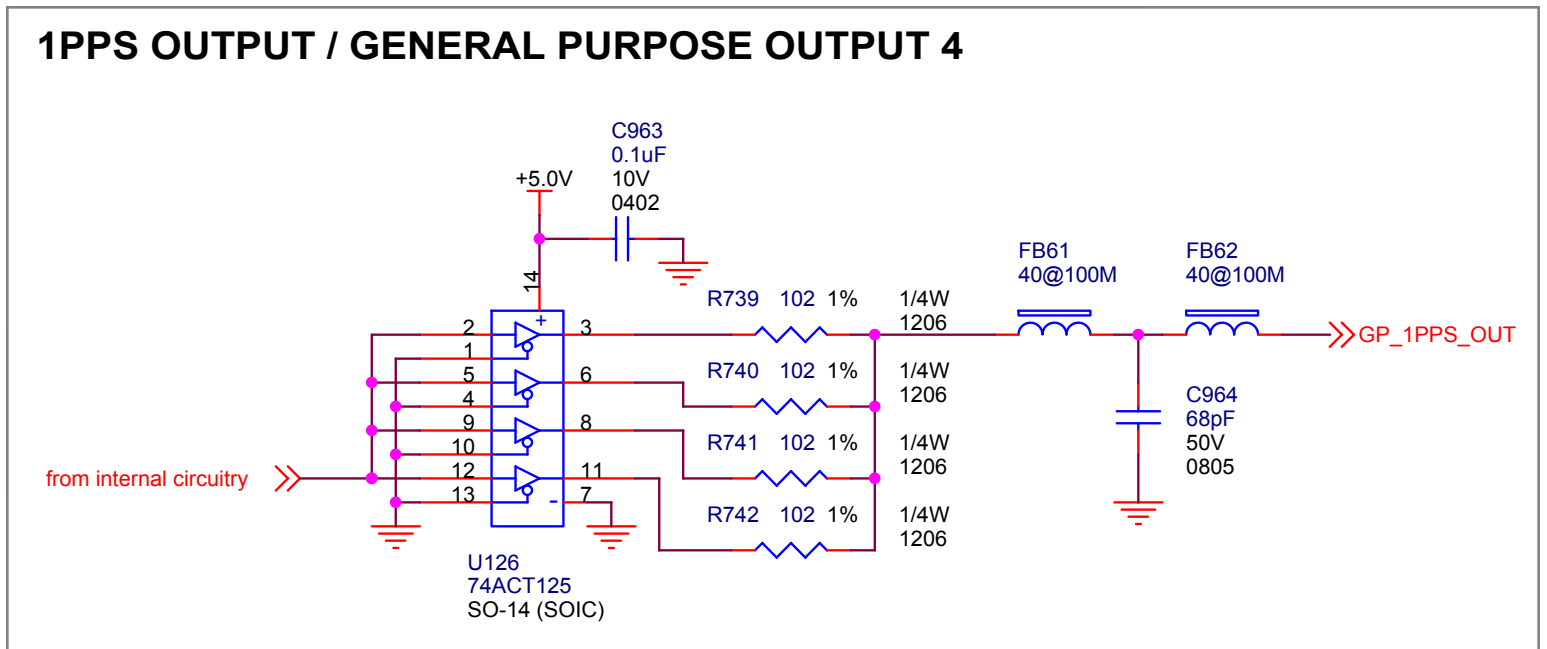

Axial lead resistors and wire jumpers are used in some parts of the GPIO circuits to facilitate modification by expert users, should modification be required for a particular installation. Below is a drawing showing that area of the circuit boards with the mentioned components and their designator numbers for easy identification.

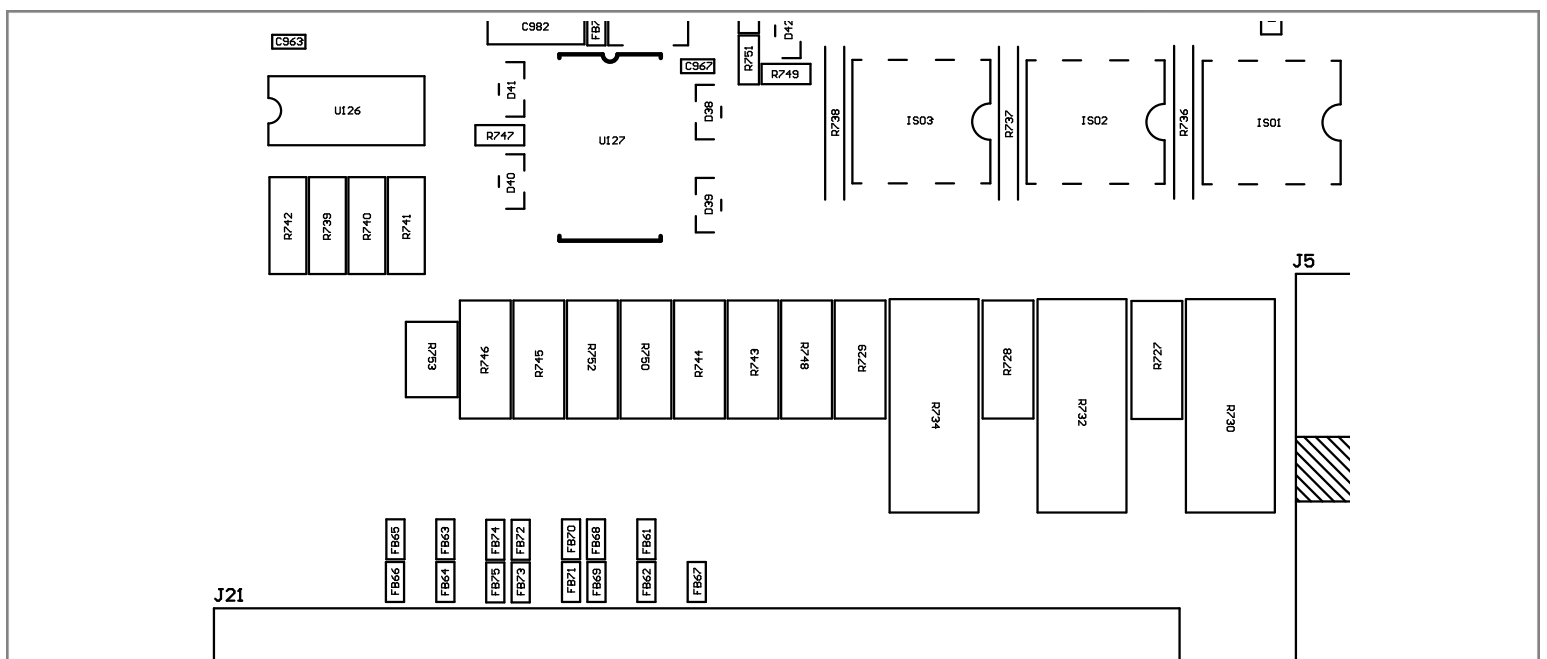

24.6 APPENDIX F: DIFFERENCES BETWEEN THE DXD-16 PTP CONNECTORS

Each of the 4 Ethernet connectors on the DXD-16 rear panel has an independent PTP port attached to it (per the IEEE1588 standard, the word 'PORT' has a special meaning and is not the same as a connector).

- **Ports 1 & 2:** Their processing is entirely dedicated to PTP. As they have no other tasks they have a higher bandwidth than ports 3 & 4, and should therefore be the first choice for very large PTP networks.
- **Ports 3 & 4:** Equally capable at the PTP level these ports we have so far measured up to 180 slaves.
- **Port 4:** For firmware updates and remote control, only P4 can be used.

24.7 APPENDIX G: FACTORY PRESETS

The following are the factory default settings.

REFERENCE		NETWORKS 1-4	
Source	Internal	DHCP	On
SYNC PARAMETERS		PTP	
BNC Input Color Framing	Off	PORT MODES 1/2/3/4	Off
BNC Input Time Jam Source	Off	BOUNDARY CLOCK DOMAIN	0
BNC Input Time Jam Resync	Off	BOUNDARY CLOCK PRIORITY 1	128
Jump Threshold	5 ms	BOUNDARY CLOCK PRIORITY 2	128
BNC INPUT SET UP A&B		PROFILE (Ports 1, 2, 3 & 4)	Standard PTP
Signal	Video	PROFILE PORT TIMING ACTION (Ports 1, 2, 3 & 4)	No Action
Set/Learn	Learn	DELAY MECHANISM (Ports 1, 2, 3 & 4)	E2E [End to End]
BNC OUTPUTS 1-16		ANNOUNCE INTERVAL (Ports 1, 2, 3 & 4)	2 sec [log 1]
Signal	SD Video	ANNOUNCE RECEIPT TIMEOUT (Ports 1, 2, 3 & 4)	3 announce intervals
Rate	525i/29.97 NTSC	SYNC INTERVAL (Ports 1, 2, 3 & 4)	1 sec [log 0]
AUDIO BASE RATE A		MIN DELAY REQ INTERVAL (Ports 1, 2, 3 & 4)	1 sync interval
Set/Auto	Set	INDEP MSTR DOMAIN (Ports 1, 2, 3 & 4)	101/102/103/104
Rate	48000 [48000]	INDEP MSTR PRIORITY 1 (Ports 1, 2, 3 & 4)	128
VSO Mode	VSO Off	INDEP MSTR PRIORITY 2 (Ports 1, 2, 3 & 4)	128
AUDIO BASE RATE B		TIME JAM DOMAIN (Ports 1, 2, 3 & 4)	100
Set/Auto	Set	TIME	
Rate	44100 -0.1% [44056]	SYSTEM TIME	TAI
VSO Mode	VSO Off	RTCLOCK	TAI
MUTE ON UNLOCK		PTP GM TIME	TAI
Outputs 1-16	Off	LOCAL TIME ZONE	-8 Hrs 00 Min
GPIO		LOCAL DAYLIGHT SAVING	0 Hr 00 Min
GPI 1	Status Clear Function	SET TIME: YYYY/MM/DD (RTC)	2020 / 01 / 01
GPI 2	Off	SET TIME: HH:MM:SS (RTC)	00:00:00
GPI 3	Off	SYSTEM TIME JAM FROM RT CLOCK	Off
GPO 1	Locked	UPPER DISPLAY (TIME & DATE DISPLAY)	System Time
GPO 2	Power Fail	LOWER DISPLAY (TIME & DATE DISPLAY)	No Display
GPO 3	Error Hold	UTC LEAP SECONDS	37
GPO 4	1PPS Out (high pulse)	TIME CODE - SMPTE 2059 SET UP	
UTILITY		DAILY JAM TIME	01 Hrs 00 Min
LCD Brightness	10	MANUAL DAILY RE-JAM	Off
LED Brightness	10		
Front Panel Lockout	Off		

24.8 APPENDIX H: MENUS, MESSAGES & DISPLAY PAGES

Below is a graphical representation of most of the menus, messages and pages (main rotation & status mode) that appear on the DXD-16 front panel display.

SET UP MENUS

The 'SET UP MENUS' section displays a grid of 100 screenshots representing the various configuration options available on the DXD-16. The menus are organized into 10 main categories, each with a 'SET UP MENUS' sidebar showing the navigation path:

- 1. REFERENCE & SYNC:** 1.1 REFERENCE, 1.2 SYNC PARAMETERS, 2.1 BNC INPUT A SET UP, 2.2 BNC INPUT B SET UP.
- 2. BNC INPUTS:** 3.1 BNC OUTPUTS 1-4, 3.2 BNC OUTPUTS 5-8, 3.3 BNC OUTPUTS 9 & 10, 3.4 BNC OUTPUTS 11 & 12, 3.5 BNC OUTPUTS 13 & 14, 3.6 BNC OUTPUTS 15 & 16, 3.7 AUDIO BASE RATE A, 3.8 AUDIO BASE RATE B.
- 3. BNC OUTPUTS:** 3.9 MUTE ON UNLOCK, 3.10 DELAY/ADVANCE 1-4, 3.11 DELAY/ADVANCE 5-8, 3.12 DELAY/ADVANCE 9&10, 3.13 DELAY/ADVANCE 11&12, 3.14 DELAY/ADVANCE 13&14, 3.15 DELAY/ADVANCE 15&16.
- 4. NETWORKS:** 4.1 NET 1, 4.1.1 NET 1 IP ADDRESS, 4.2 NET 2, 4.3 NET 3, 4.4 NET 4.
- 5. PTP:** 5.1 PORT MODES, 5.2 GRANDMASTER [GROUP], 5.3.1 PORT 1 TIMING, 5.3.2 PORT 1 INDEP MASTER, 5.3.4 PORT 1 TIME JAM, 5.3.1 PORT 1 CONTROLS, 5.3.2 PORT 1 INDEP MASTER, 5.3.4 PORT 1 TIME JAM.
- 6. GPS:** 6.1 SATELLITES SELECTION, 6.2 GPS SETTINGS, 6.3 ADVANCED GPS SETTINGS, 6.2.1 TCG 1 SETTINGS, 6.2.2 TCG OPERATIONS.
- 7. TIME:** 7.1 TIME STANDARDS, 7.2 REAL TIME CLOCK, 7.3 TIME & DATE DISPLAY, 7.4 LEAP SECONDS.
- 8. TIME CODE:** 8.1 SMPTE 2059 SETUP, 8.2 LTC GENERATOR 1, 8.2.1 TCG 1 OPERATIONS, 8.2.2 TCG OPERATIONS.
- 9. GPIO:** 9.1 GPIO INPUTS, 9.2 GPIO OUTPUTS.
- 10. UTILITY:** 10.1 BRIGHTNESS, 10.2 FRONT PANEL LOCKOUT, 10.3 CLEAR MEMORY, 10.4 REBOOT, 10.5 FEATURE KEYS.

MESSAGES

The 'MESSAGES' section displays a row of 7 screenshots showing various error and status messages that can appear on the DXD-16 front panel display:

- 9.2 FRONT PANEL LOCKOUT:** ERROR FrontPanelLockedOut. Press Any Key to Clear.
- 4. OUTPUTS:** PTP NO PORT. Possible causes include: PORT MODE not assigned, Missing IP Address, Network disconnected. Press Any Key to Exit.
- 6. GPS:** DXD/GPS NOT INSTALLED. The GPS Receiver is required for these menus. To purchase please contact your Brainstorm dealer.
- 8. TIME CODE:** LTC FEATURE KEY NOT FOUND. The TIME CODE feature is not yet available. To pre-order, please contact your Brainstorm dealer.
- 9.5 FEATURE KEYS:** FEATURE KEYS. Set Feature Key values? Please confirm. Press UP to set, now Press DOWN to set later.
- 10.3 CLEAR MEMORY:** CLEAR MEMORY. You have requested that all saved Data should be Cleared and a System Reboot performed. Please confirm. Press UP to Clear now Press DOWN to Clear later.
- TIME & DATE:** TIME JAM. A Time Jam to PTP has completed successfully. Press Any Key to Exit.

MAIN ROTATION DISPLAYS

The 'MAIN ROTATION DISPLAYS' section shows four screenshots of the primary information displays on the DXD-16:

- OUTPUTS:** Shows output configurations for 1-4, 5-8, 9&10, 11&12, 13&14, and 15&16, including signal type (e.g., 1080P/25, NTSC/29.97) and status (e.g., LOCKED / PTP SLAVE).
- REFERENCE SOURCES:** Shows the current reference source (e.g., MAIN: INPUT A / WC, BNC) and its status (LOCKED).
- PTP PORTS:** Shows the PTP mode (SLAVE or MASTER) for each port (P1, P2, P3, P4) and its status (LOCKED / PTP SLAVE).
- TIME & DATE:** Shows the current system time and date (e.g., Apr 20 2020) and the time code source (GPS).

STATUS DISPLAYS

The 'STATUS DISPLAYS' section shows four screenshots of detailed status information:

- UNIT INFORMATION:** Displays hardware details such as Model (Brainstorm DXD-16), Serial Number, Version, Software, UIC#, and Input/Output status.
- NETWORKS:** Shows network configuration for three networks, including IP Address, Subnet Mask, and Gateway.
- TIMES:** Displays system time, RT Clock, GPS, and Grandmaster information, along with TOD-OW drift.
- GPS RECEIVER:** Shows GPS receiver status, including Antenna, Detect, Environment, High Striding, and various signal quality metrics.