



General Description

The Rane ME 60S Stereo Constant-Q Equalizer is a two-channel, $\frac{1}{3}$ -octave design, housed in a two rack-space unit. It features a Range switch for high slider resolution in the ± 6 dB mode, equivalent resolution to 45 mm sliders found on larger models. The ± 12 dB mode provides a wide range of control over system audio.

The ME 60S evolved by combining two ME 30 equalizers in one unit and then embellishing with two adjustable band-limiting filters on the low and high end. Though consuming only 12 watts of power, a Power switch is added to the ME 60S (the ME 30S consumes 7 watts and does not have a Power switch).

The active filter sections feature Rane's innovative constant-Q (constant bandwidth) design. Constant-Q means the bandwidth of each individual filter is guaranteed to be narrow enough to prevent unwarranted interaction between filters, yet wide enough to produce exactly the type of correction curve demanded by even the most unusual acoustic surroundings. This differs

dramatically from conventional designs of the past, encumbered with the unfortunate characteristic of changing bandwidth when changing boost/cut amounts.

Front panel controls and indicators include an overall rotary Level control for each channel as well as Overload indicators. Passive pushbutton Bypass switches feature LED indicators, avoiding ambiguity by being *on* when the unit is Bypassed. (A *passive* Bypass switch requires no power to operate. This allows completion of the audio path should power fail in the ME 60S.)

The rear of the ME 60S provides an unusually flexible array of connector choices. Inputs and Outputs are electronically balanced designs, capable of unbalanced operation when required. They accept and drive all possible signal levels into normal load impedances. Balanced applications choose between the XLR or $\frac{1}{4}$ " Tip-Ring-Sleeve balanced connectors. Unbalanced sources also may tie to the ME 60S through mono $\frac{1}{4}$ " connectors (no ring connection).

Features

- Constant-Q Bandwidth Design
- Overall Level Control
- 20 mm Filter Slide Controls
- ± 6 dB or ± 12 dB Slider Range
- Sweepable Low & High Cut Filters
- Passive Bypass Switch
- Grounded Center Detents at 0 dB
- Infrasonic, Ultrasonic, & RFI Filters
- Fully Balanced XLR Inputs and Outputs
- $\frac{1}{4}$ " TRS Balanced/Unbalanced Inputs and Outputs
- **NEW!** ± 6 dB or ± 12 dB Slider Range
- **NEW!** Universal internal switching power supply (100-240 VAC)



Features & Specifications

Parameter	Specification	Limit	Units	Conditions/Comments
Equalizer:				
.....Channels	Two			
.....Bands	(2x30) 1/3-Octave ISO Spacing			From 25 Hz to 20 kHz
.....Type	Constant-Q			
.....Accuracy	3		%	Center frequency
.....Travel	20		mm	Positive grounded center detent
.....Range	±12	1	dB	
Inputs:	Active Balanced/Unbalanced			
.....Connectors	XLR and 1/4" TRS			
.....Impedance	>20k Balanced	1%	Ω	
.....Maximum Level	+21	1	dBu	
Outputs:	Active Balanced/Unbalanced			
.....Connectors	XLR and 1/4" TRS			
.....Impedance	400 Balanced 200 Unbalanced	1%	Ω	
.....Maximum Level	+21 Balanced +15 Unbalanced	1	dBu	2 kΩ
	+19 Balanced +13 Unbalanced	1	dBu	600 Ω
Overall Gain Range	Off to +8 (Balanced Out)	min	dB	Sliders centered
RFI Filters	Yes			
Passive Bypass Switches	Yes			
Overload LED Threshold	4	1	dB	Below clipping
Low Cut Filter	10-250 Hz, 12 dB/octave	3%	Hz	Butterworth
High Cut Filter	3k-40 kHz, 12 dB/octave	3%	Hz	
Frequency Response	20-20 kHz	±0.5	dB	
	10-40 kHz	+0/-3	dB	
THD & Noise	0.008	.002	%	+4 dBu, 20-20 kHz
IM Distortion (SMPTE)	0.005	.003	%	60 Hz / 7 kHz, 4:1, +4 dBu
Signal-to-Noise Ratio	re +20 dBu re +4 dBu			20 kHz noise BW; balanced out
	112 96	2	dB	Sliders centered, unity gain
Channel Separation	75	3	dB	1 kHz
Common Mode Rejection	46	1	dB	1 kHz
Maximum Power	12		W	
Universal Line Voltage	100-240 VAC, 50/60 Hz		VAC	12W
Unit: Agency Listing				UL/cUL/CE
Unit: Construction	All Steel			
.....Size	3.5" H x 19" W x 8.5" D (2U)			(8.9 cm x 48.3 cm x 21.6 cm)
.....Weight	9 lb			(4.1 kg)
Shipping:				
.....Size	4.5" x 20.3" x 13.75"			(11.5 cm x 52 cm x 35 cm)
.....Weight	12 lb			(5.0 kg)
<i>Note: 0 dBu=0.775 Vrms</i>				

Block Diagram

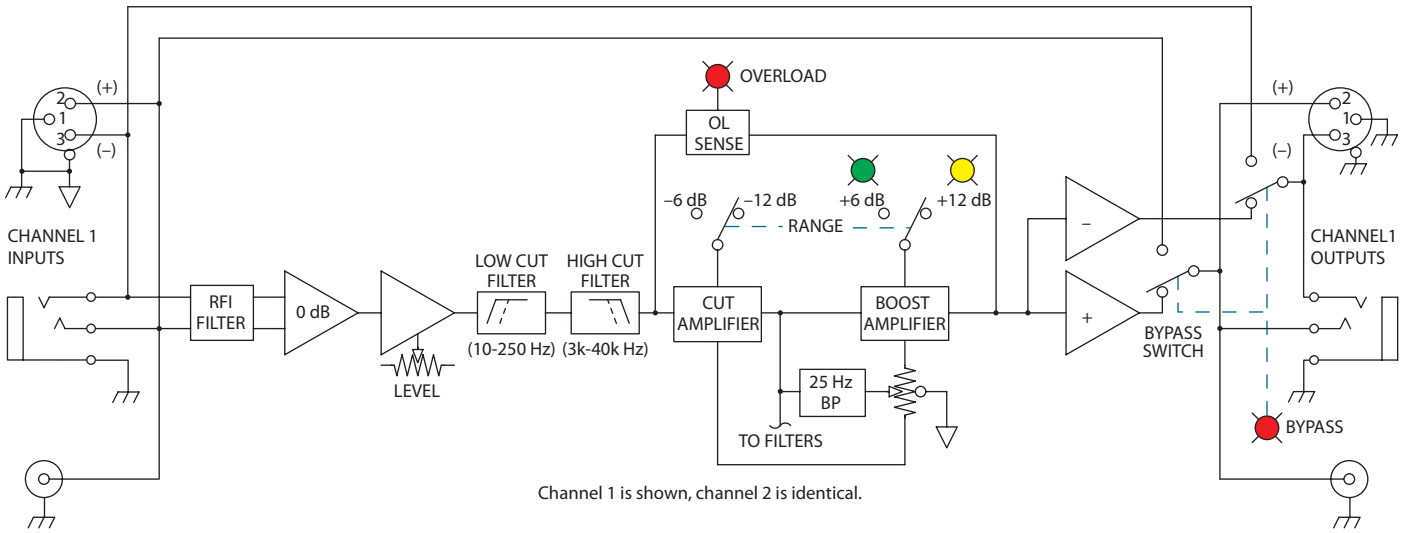

Application Information

The ME 60S is constructed using only precision audio-grade components and advanced integrated circuits, all assembled onto mil-spec glass-epoxy printed circuit boards.

The adjustable filters are useful when it is desirable to band limit the audio signal. For instance, restricting high frequencies to match the incoming signal usually produces the most quiet system. And a common use for the Low Cut Filter is limiting the signal going to 70-volt speaker systems. Often low frequencies saturate the loudspeaker transformers. Restricting these signals greatly improves system intelligibility. Full bandwidth use requires positioning both sliders to their lower limits. This effectively removes the filters and guarantees 20-20 kHz ± 0.5 dB performance.

Constant-Q graphic equalizers arose from the sound professional's need for greater control with less interaction than previously possible with conventional equalizers. You use a constant-Q graphic the same way you use a conventional graphic. You just get the desired results quicker, with far less after adjustment to the adjacent sliders.

The accompanying figures dramatically show the advantages of constant-Q designs. For more technical information, consult the references on the next page. Most are available at www.rane.com/library.html.

To accurately set the ME 60S, we highly recommend the Rane RA 30 Realtime Analyzer. Not only will it help you align your equalizer, it's a high-resolution SPL meter and a stereo VU meter — and it's fun to watch.

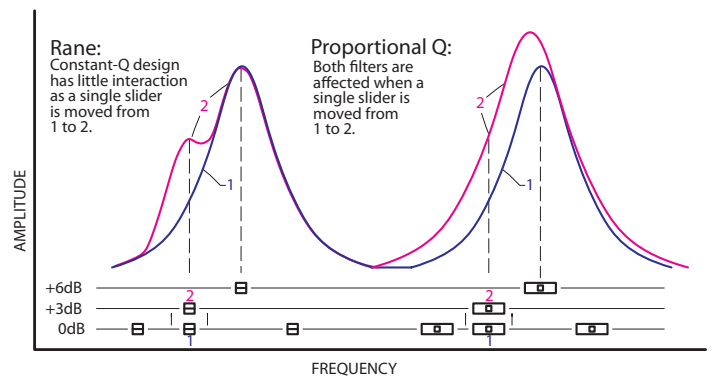
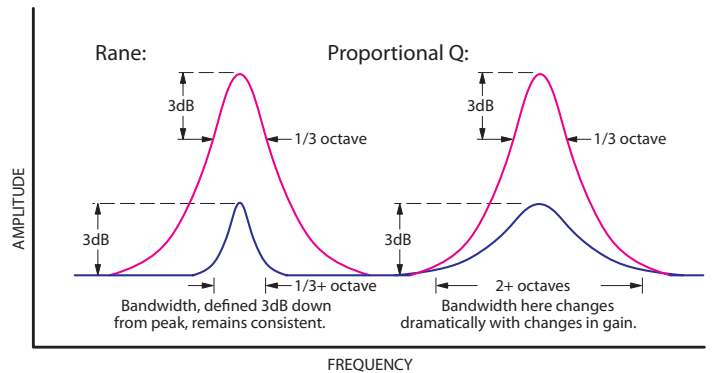

Rear Panel



Architectural Specifications

The graphic equalizer shall be a two channel model of constant-Q design to minimize interactions between adjacent bands, and shall occupy two rack spaces (2U). Each channel shall have thirty (30) frequency bands located on standard ISO center frequencies. Each band shall have a bandwidth of 1/3-octave. A switchable boost/cut range of 12 dB or 6 dB shall be provided. A detented and positively grounded 0 dB point shall be provided on 20 mm linear sliders with dust dams.

Low and high cut filters shall be provided with 12 dB/octave slopes and adjustable corner frequencies. A rotary overall level control shall be provided for each channel with a range from off to +8 dB of gain when used in balanced mode. The unit shall

provide a passive bypass feature for each channel requiring no power to operate. LED indicators shall be provided to indicate boost/cut range, overload and bypass conditions.

The inputs and outputs shall be active balanced/unbalanced designs terminated with XLR and 1/4" TRS (tip-ring-sleeve) connectors. RFI, infrasonic and ultrasonic filters shall be provided.

The unit shall incorporate a front panel power switch. The unit shall be capable of operation by means of its own built-in universal power supply operating at 100-240 VAC and meet CE requirements. The unit shall be UL and cUL listed. The unit shall be entirely constructed from cold-rolled steel.

The unit shall be a Rane Corporation ME 60S microGraphic Equalizer.

Available Accessories

- RA 30 Realtime Analyzer
- SC 1.7 Security Cover

References

1. D. Bohn, "Constant-Q Graphic Equalizers," *RaneNote*, (1982).
2. D. Bohn, "A New Generation of Filters," *Sound and Video Contractor*, vol. 2, pp. 36-39 (Feb. 1984).
3. T. Pennington, "Constant-Q," *Studio Sound*, vol.27, pp. 82-85 (Oct. 1985).
4. D. Bohn, "Constant-Q Graphic Equalizers," *J. Audio Eng. Soc.*, vol. 34, pp. 611-626 (September 1986).
5. D. Bohn, "Exposing Equalizer Mythology," *RaneNote*, (1986).
6. D. Bohn, "Operator Adjustable Equalizers," *RaneNote*, (1990).

Most of these documents may be found at our website, www.rane.com/library.html