



P Y P - 1 S t e r e o C o n t r o l P r e a m p l i f i e r

*Owner's Manual*

▼ Please complete warranty card, detach and return ▼

Thank you for purchasing this PYLE product. To activate your warranty, please mail this card within 10 days.

warranty registration card



PYLE PRO ELECTRONICS

Name \_\_\_\_\_

Address \_\_\_\_\_

City, State ZIP \_\_\_\_\_

Model No. \_\_\_\_\_

Serial # (if available) \_\_\_\_\_

Date of Purchase \_\_\_\_\_

- Purchased at:**
- Music Products Store
  - Sound Contractor/Installer
  - Mail Order
  - Catalog Merchandiser
  - Other \_\_\_\_\_



Your Pyle Pro PYP-1 Preamplifier has been created to provide the home stereo audiophile with a sophisticated control center for tailoring the sound quality from multiple input sources and directing the signal to a sound processor or power amplifier for playback.

The PYP-1 features a balance control, master volume and mic output level controls, and BASS, MID, TREBLE, and LOUDNESS controls for improving and adjusting sound quality.

The PYP-1 provides both RCA and 1/4 inch connectors on the aux input and output jacks, expanding options when selecting input and output devices.

Please read this manual thoroughly before you attempt to set up and use this peramplifier. It contains a range of installation suggestions as well as instructions to ensure safe usage. Installed properly, you can expect years of trouble-free service from this product.



FEATURES AND CONTROLS

FRONT PANEL

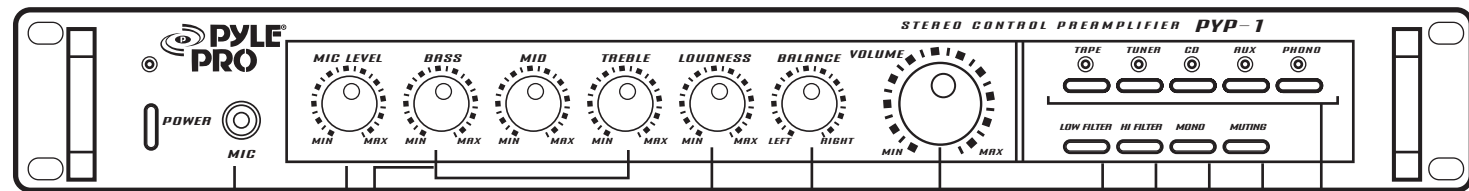

- Power On/Off**
  - MIC**
  - MIC LEVEL** MIN MAX
  - BASS** MIN MAX
  - MID** MIN MAX
  - TREBLE** MIN MAX
  - LOUDNESS** MIN MAX
  - BALANCE** LEFT RIGHT
  - VOLUME** MIN MAX
  - PHONO**
  - AUX**
  - CD**
  - TUNER**
  - TAPE**
  - LOW FILTER**
  - HI FILTER**
  - MONO**
  - MUTING**
- Tone Controls**  
Adjusts levels of BASS, MID, and TREBLE
- Microphone Input Jack and Level Control**  
Lets you connect and adjust input signal from microphone
- Master Volume Control**  
Adjusts output level of speakers
- Balance Control**  
Controls relative volume of left and right speakers
- Loudness Control**  
Compensates for loss of low frequencies at low volumes.
- Low Frequency Filter**  
For elimination of turntable rumble and other low frequency noise
- High Frequency Filter**  
For elimination of record scratches and other high frequency noise
- Stereo/Mono Switch**  
Selects Stereo or Mono input signal.
- Muting Switch**  
Reduces volume level by 20dB
- Input Source Selectors**  
Select signals from TAPE, TUNER, CD, AUX or PHONO jacks.

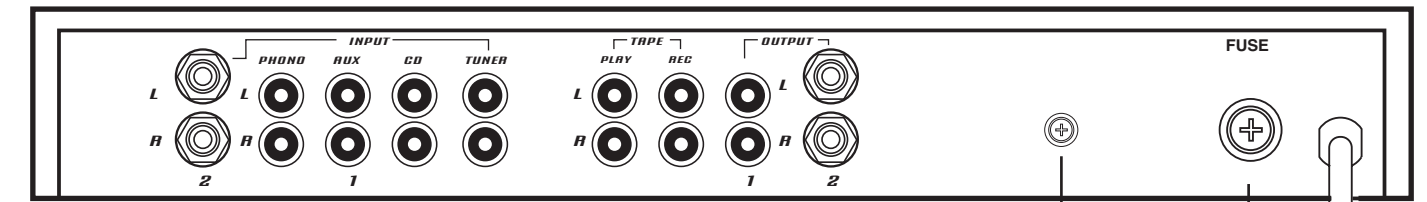

- Ground Screw**
- Fuse Holder**
- Left and Right Output Connectors**  
The PYP-1 offers a choice of 1/4" or RCA type output jacks for connecting to the inputs of your graphic equalizer or power amplifier.
- Tape Recorder Inputs/Outputs**  
For recording to and playing from a tape player or recorder.
- Left and Right Input Connectors**  
For connecting the PYP-1 to a TAPE PLAYER, TUNER, CD, AUX, and PHONO input sources. The AUX features both 1/4" or RCA type input jacks.



**INSTALLATION GUIDELINES**

**Input connections**

The PYP-1 accepts a broad range of input sources, including:

- Compact Disc (CD) player
- Cassette, Reel-to-Reel or other tape recorder or player
- Radio Tuner
- Turntable

These can be connected via either 1/4" or RCA type jacks to the input jacks on the rear panel of the PYP-1

**Connecting a phono turntable**

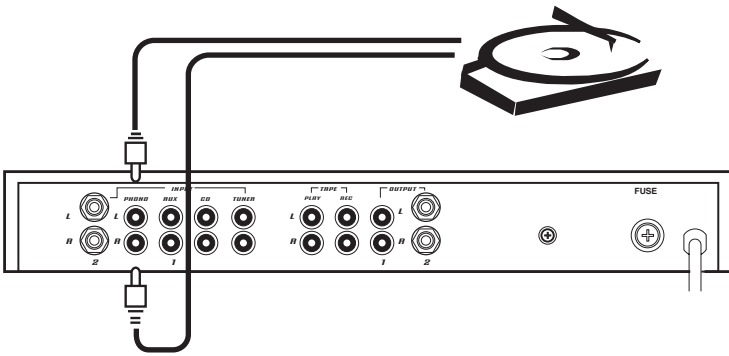

**Connecting an auxiliary input source**

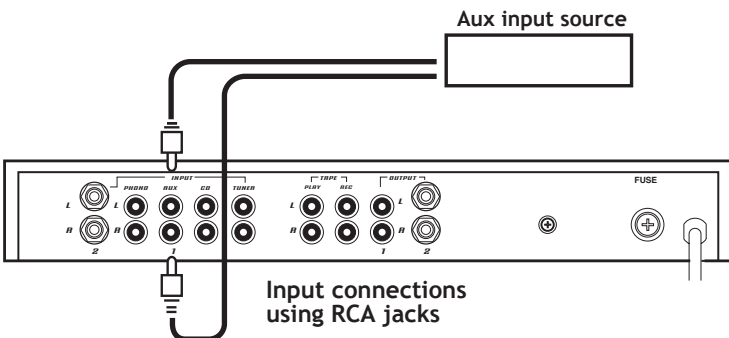

- OR -

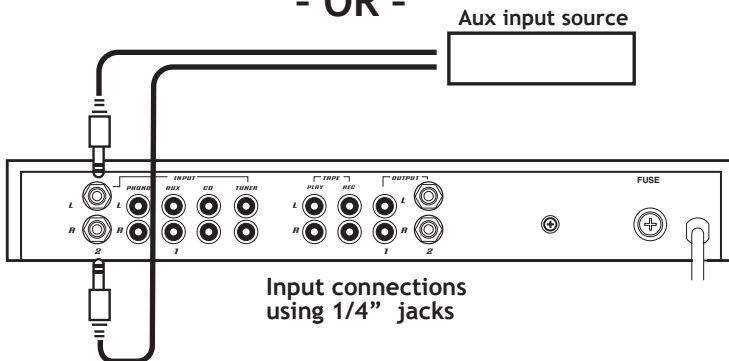

**Connecting a CD Player**

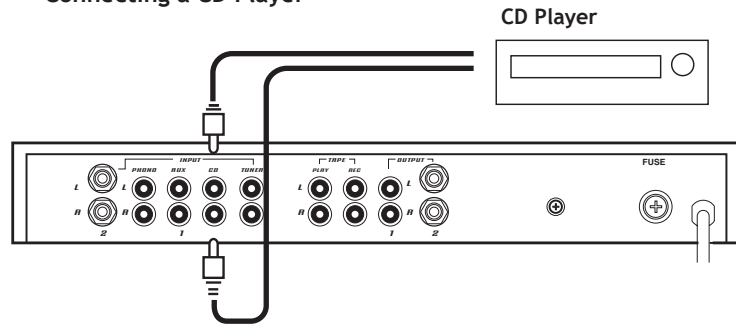

**Connecting a Radio Tuner**

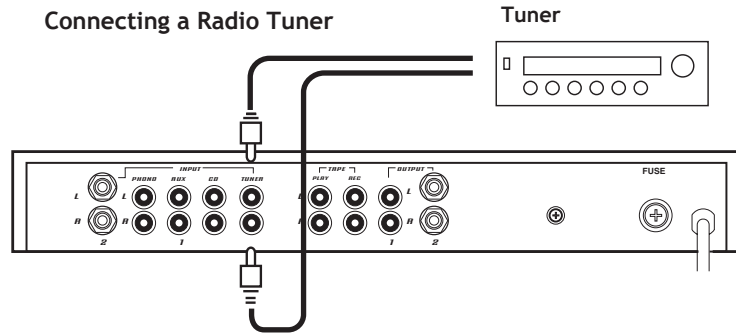

**Connecting a Microphone**

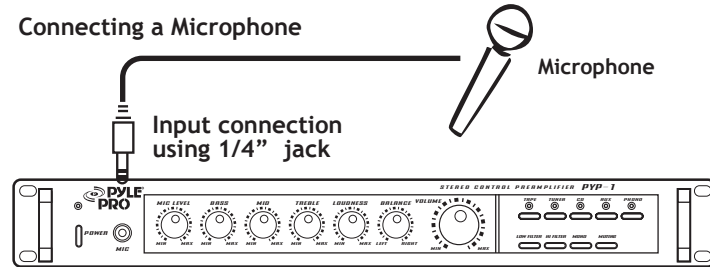

**Output Connections to Amplifier or Signal Processor**

The PYP-1 has been designed to provide output to a power amplifier or sound processor. Output connections may be made using either the RCA or 1/4" connectors on the rear panel.

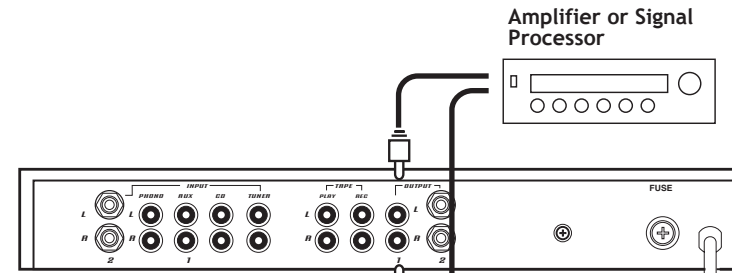

NOTE: These diagrams show hookups using the RCA type jacks, but you can use the 1/4" jacks instead with similar results.

**Recording from/Playing to the PYP-1 from a tape recorder/player**

The PYP-1 has been designed to serve as an audio source for tape recording as well as to accept tape playback as an input source. Connect the REC IN jack of your tape deck to the REC jack of the PYP-1, and the TAPE OUT jack of the deck to the PYP-1 PLAY jack.\*

\* Terminology for the tape deck input and output may vary. See your tape deck owner's manual for questions.

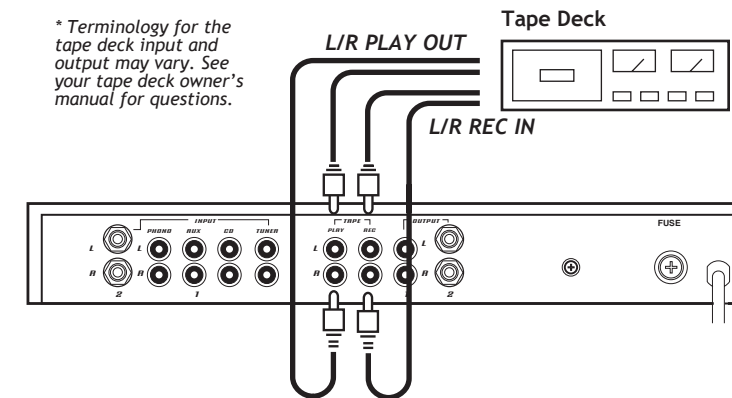

**Grounding the preamplifier**

Grounding your turntable to an earth ground is a good idea in order to reduce or eliminate hum or static that the phono system may introduce to the audio signal path. Securely fasten a wire from the ground screw on the rear panel to the ground lead from your turntable.

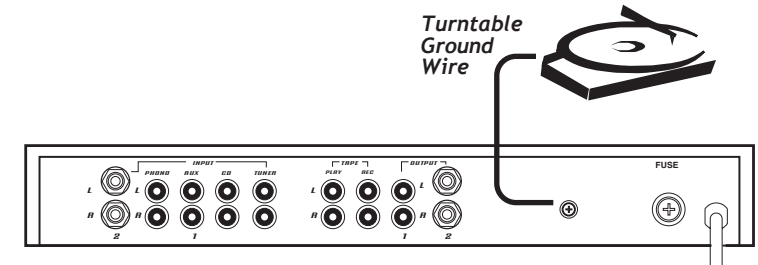

**Selecting the Input Source**

Select signals from TAPE, TUNER, CD, AUX or PHONO jacks using the push button switches on the front panel.

**Adjusting Volume and Tone**

Adjust the various tone controls, mic input level (if used) and master volume to suit your taste or performance requirements.

**Adjusting the Balance**

The balance control positions the audio program material in your listening environment by balancing the relative volume of left and right channels. This may be highly useful in a mobile performance system where environmental acoustics vary widely.

**Filtering the audio program**

The Low Frequency Filter has been designed to assist in the elimination of low frequency noise such as turntable rumble. Engage this filter by pressing the button marked LOW FILTER.

The High Frequency Filter removes high frequency noise from the audio stream, such as that caused by record scratches. This filter is activated by pressing the HIGH FILTER button.

**Muting the audio**

When you need to lower the volume level temporarily, such as when changing records or tapes, you may wish to take advantage of the PYP-1's muting function. This function reduces the audio output level by 20 dB when the MUTE button is depressed. Pressing again returns the audio to the full level set by the MASTER VOLUME control.

### Connecting to standard AC power

After making all other connections, set the POWER switch to OFF position. Then connect the power cord to a standard AC outlet.

### Mounting the PYP-1

The PYP-1 is designed to accept standard rack mounting installations. Two slots on each end of the front panel make it suitable for such an installation.

Tightly secure four mounting screws (not supplied) through these four slots and into your standard electronics equipment rack.

### Caring for your PYP-1 Stereo Control Preamplifier

This component uses a 250V 0.5A fuse for protection from power surges and short circuits. If the unit suddenly shuts down and will not turn on, it is likely that this fuse has blown.

To replace the fuse:

1. Locate the fuse holder on the rear of the cabinet and unscrew the fuse compartment cap.
2. Remove the old fuse and replace it with an identical, serviceable fuse.

**CAUTION!** Never use a fuse with a higher rating!

3. Replace the fuse compartment cap.

### PYP-1 Specifications

#### Input Sensitivity/Impedance

Mic	0.5mV/600 Ohms
Phono	3.0mV/47k Ohms
Tape/Tuner/CD/Aux	150.0mV/47K Ohms

#### Output Level/Impedance

Tape Rec	150.0mV/100k Ohms
Pre Output	500.0mV/47k Ohms

#### Total Harmonic Distortion

Mic	<0.4%
Phono	<0.04%
Tape/Tuner/CD/Aux	<0.02%

#### Frequency Response

5Hz to 30k Hz (+0, -3dB)

#### S/N Ratio

Mic	>50dB
Phono	>70dB
Tape/Tuner/CD/Aux	>80dB

#### Tone Control

Bass	+/-12dB at 100 Hz
Mid	+/-6dB at 1k Hz
Treble	+/-12dB at 10k Hz

#### Loudness Control

+4/0/+2dB at 100/1k/10k Hz

#### Power Requirement

AC 110V/60 Hz or 230V/50 Hz

#### Dimensions

18 7/8 x 2 3/8 x 7 7/8  
(480 x 60 x 200)

#### Limited Warranty

All PYLE PRO products are carefully constructed and tested before shipment. Units purchased in the USA are warranted to be free of defects in material and workmanship for two (2) years from the date of purchase. This warranty is limited to the original retail purchaser of the amplifier.

Should the unit fail due to factory defects in material or workmanship, your unit will be repaired or replaced at the sole discretion of PYLE.

To obtain warranty service, you must first call our Consumer Return Hotline at (718) 236-6948 to obtain a Return Authorization Number. This R.A. # must appear on the outside of your package and on all paperwork relating to your return.

When returning the unit to us for warranty service, it must be carefully packed and shipped, prepaid, to:

R.A.#: \_\_\_\_\_  
PYLE PRO Service Center  
1600 63rd Street  
Brooklyn, NY 11204

You must also include the following items with your return:

- A copy of your sales receipt or other proof of purchase
- A brief letter, indicating the problem you are experiencing with the product
- Include in your letter your return address, daytime phone number and R.A. number
- Also include a check or money order for \$15.00 for return shipping, handling and insurance, or provide your Visa/MC number with expiration date.

Our obligation under this warranty is limited to the repair or replacement of the defective unit when it is returned to us prepaid. This warranty will be considered void if the unit was tampered with, improperly serviced or subject to misuse, neglect or accidental damage.



Place  
Stamp  
Here

▼ Please complete warranty card, detach and return ▼

