

NOTES:

- Transformer color codes shown are shown in the table to the right and in the diagram below
- 25V amplifier connection example shown below provides 0.5W of power (load) for each speaker
- Unused transformer wires must be insulated from each other, the enclosure and ground
- Speakers on the same amplifier line can be connected at different tap (power) levels
- Call-in switch is momentary contact, normally open, connect as specified by control system manufacturer
- Verify proper XLR wiring with the connected XLR equipment manufacturer

COLOR		AT 25V
Green		0.25W
Yellow		0.5W
Orange		1.0W
Black		COMMON

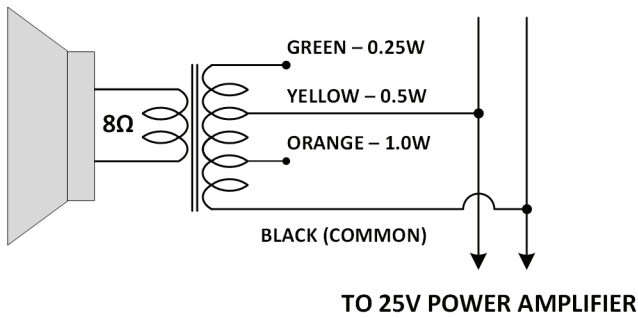

3-Pin XLR (male)

Rear View (solder side)

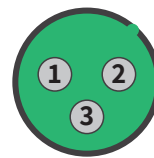

- Pin 1 - Shield (ground)
- Pin 2 - Hot (positive)
- Pin 3 - Cold (negative)

Momentary Switch

