

DHX & DHXR4 UHF



USER'S MANUAL

ANY SPOT[®]

WIRELESS MICROPHONE SYSTEM

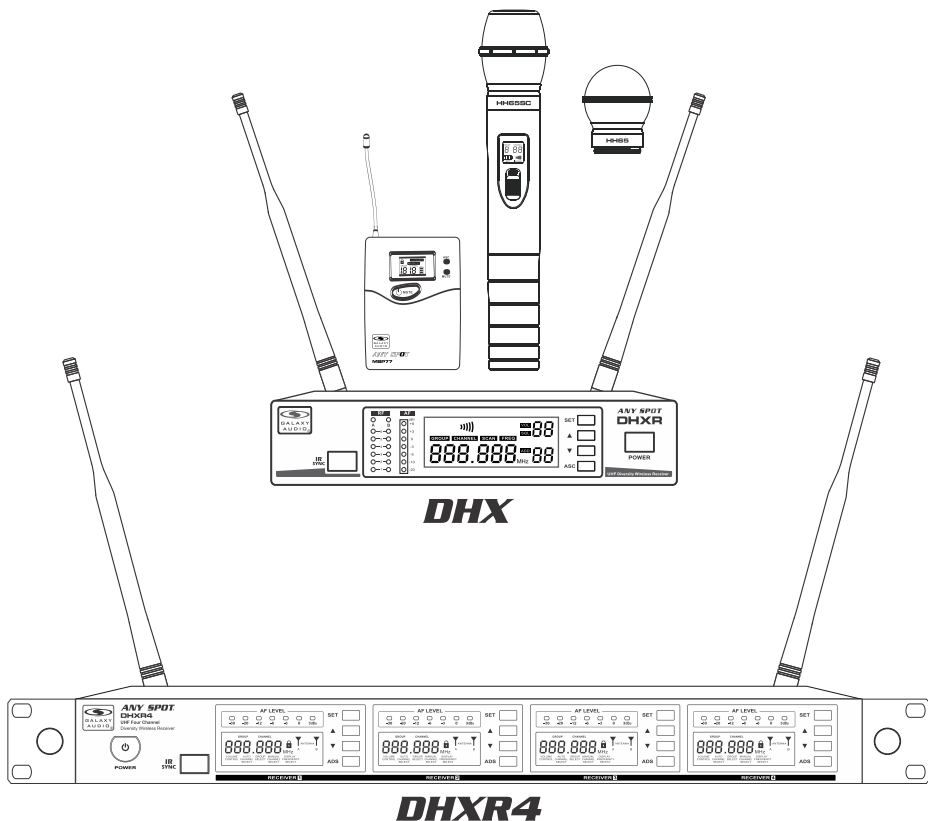

**MAKERS OF THE ORIGINAL
HOT SPOT PERSONAL MONITOR**

Contents

DHXR System Components.....	1
DHXR4 System Components.....	2
Rack-Mounting the DHXR.....	3
Rack-Mounting the DHXR4.....	4
Functions of the DHXR Receiver.....	5
Functions of the DHXR4 Receiver.....	6
HH65/HH65SC Handheld Transmitter.....	7
MBP77 Body Pack Transmitter.....	8
DHXR System Setup.....	9
DHXR4 System Setup.....	10
Setting Up Multiple Receivers.....	11
Troubleshooting.....	12
Specifications.....	13
Accessories and Replacement Parts.....	14
Frequency Chart.....	15
Wireless Tips.....	16
DTV Frequency Ranges & FCC Consumer Alert.....	17

DHX & DHXR4 System

DHX and DHXR4 Systems

Thank you for choosing the Galaxy Audio DHX or DHXR4 Wireless Microphone System. You have joined hundreds of thousands of other satisfied Galaxy customers. Since 1977 Galaxy Audio's professional experience in design and manufacturing ensure our products quality, performance and reliability.

For users who need an advanced UHF wireless system, the DHX and DHXR4 provides an excellent solution. With 120 selectable channels, they are perfect for applications such as live shows, broadcast, meetings, & musical instruments. Touch buttons and liquid crystal displays allow for a quick and simple system setup. The "Quick Start Guide" included in your system will provide all the details you need to operate the system efficiently.

Frequency Band

Most countries closely regulate the radio frequencies used in the transmission of wireless information. These regulations state which devices can use which frequencies, and help to limit the amount of RF (radio frequency) interference in all wireless communications. The DHXR4 offers 120 selectable channels within either the 584-607MHz (Code D) or 518-535MHz (Code N) frequency ranges.

To facilitate system setup and protect against RF interference, each system comes with multiple predefined frequency groups and channels. When using a single receiver/transmitter, the operating frequency will generally not have to be changed. In an installation with multiple receivers/transmitters, each set must operate on a separate channel from the others. The group and channel system provides an optimum frequency spread when using multiple receiver/transmitter systems.

DHXR System Components

All DHXR Systems Include:

- DHXR Receiver
- Power Supply
- Two Antennas
- MREWD Single/Dual Rack Kit
- Quick Start Guide

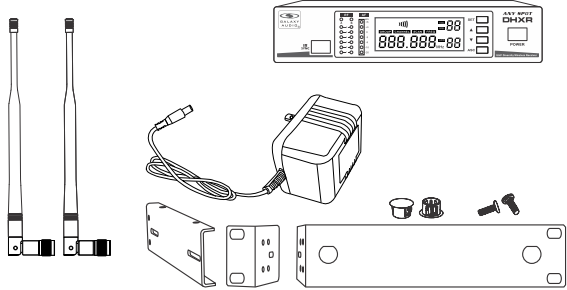

HH65/HH65SC Handheld System includes:

- Handheld Mic Transmitter with HH65 Dynamic or HH65SC Super Cardioid Condenser, Interchangeable Heads

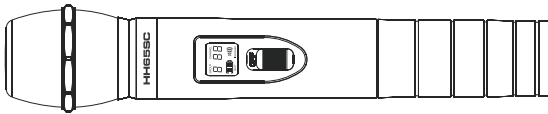

MBP77 Lav/Headset Systems includes:

- MBP77 Body Pack Transmitter.
- Mic (Choice of Uni Lavalier or Uni Headset)



HS-U3BK

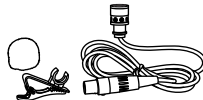

LV-U3BK



This is just a sample of the many headset and lav options available from Galaxy Audio.

DHX177 Guitar system includes:

- MBP77 Body Pack Transmitter and 1/4" to Mini 3-pin Guitar Cable.

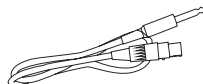

Guitar Cable



DHXR4 System Components

All DHXR4 Systems Include:

- DHXR4 Receiver
- 1/4" to 1/4" Audio Cable
- Power Supply
- Two Antennas
- Extension Kit x2
- Rack Ears
- Quick Start Guide
- Two Antenna Plugs
- 6 Screws

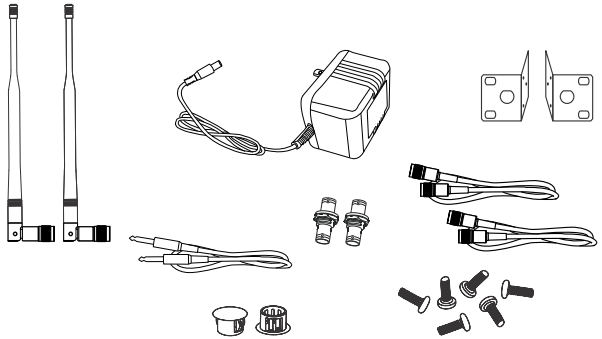
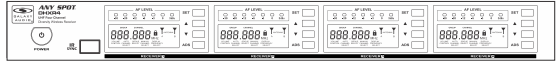

Transmitter Options:

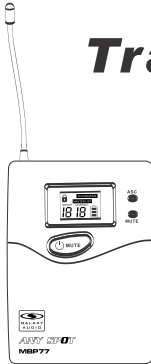

MBP77
Body Pack
Transmitter

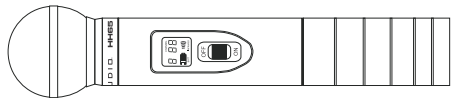

HH65 / HH65SC Handheld Mic/Transmitter

Visit our website
www.galaxyaudio.com
to see all of our great
headset & lavalier
options

Rack-Mounting a Single DHX Receiver



BNC CONNECTOR & CABLE:
For front mounting antenna to rack ears.
Part# AS-EXT50/BNC (optional)



Included MREWD Single/Dual Rack Kit
Long and Short Rack Ears needed
for Single Unit Mounting

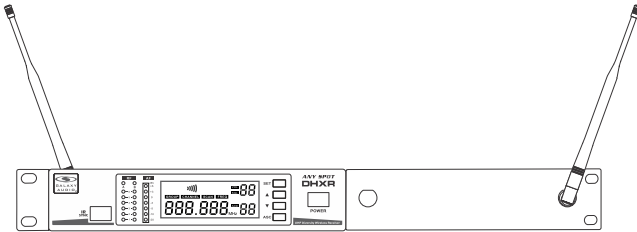

Rack-Mounting Two DHX Receivers

Rack Brackets for mounting
Two Receivers side by side
Included Parts: MREWD

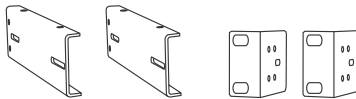

Included MREWD Single/Dual Rack Kit
Two Short Rack Ears and Two Coupler
Halves needed for Dual Unit Mounting

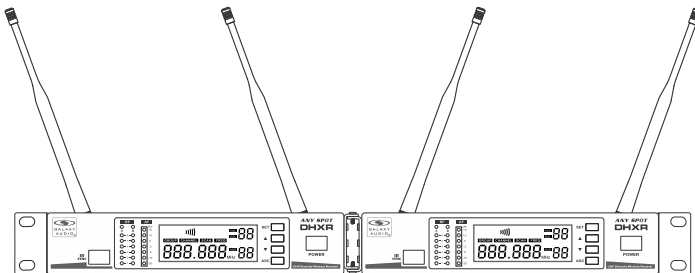

Rack-Mounting the DHXR4 Receiver

Rack-Mounting the Receiver

Maintain a line of sight between transmitter and antenna.

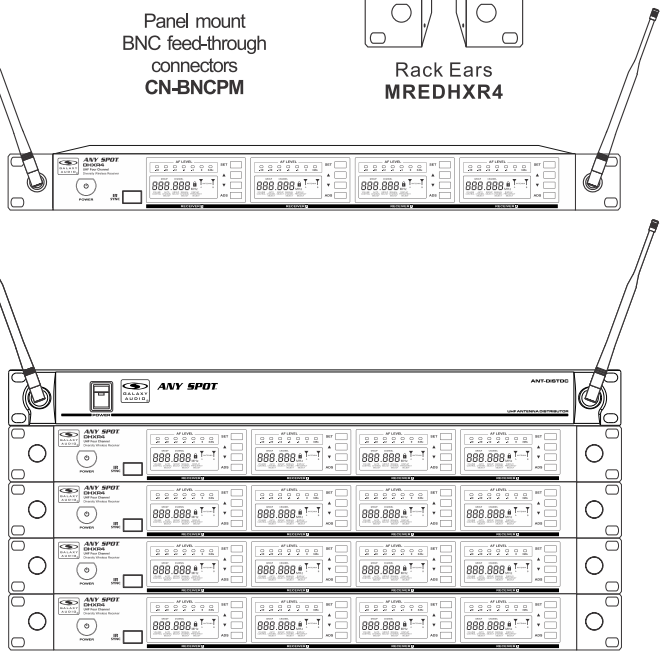
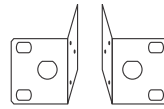
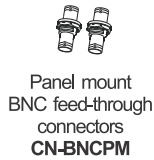
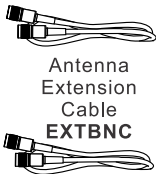

Shown with optional **ANT-DISTDC** antenna distributor.



ANT-DISTDC Info

Four **DHXR4** receivers

The **ANT-DISTDC** will provide DC power to operate up to 4 **DHXR4** or **DHXR** Receivers.

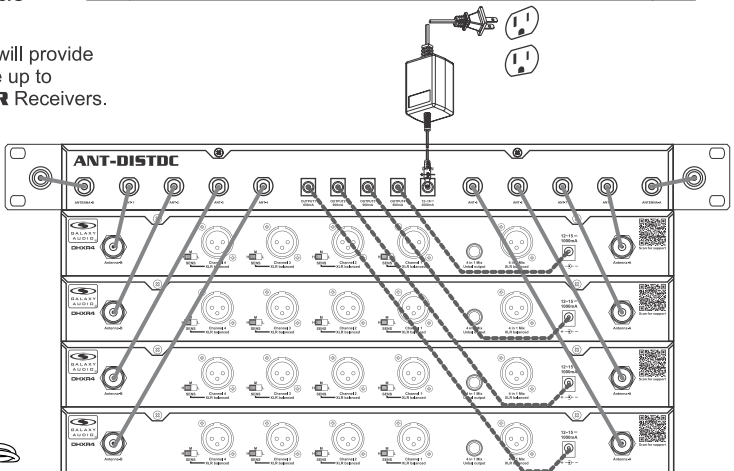

Ten BNC connecting cables (included)
Two BNC feed through connectors (included)
Four power supply cables (included)

1. BNC Cables —————
2. Power Supply Cable - - - - -

DHXR Receiver Features

Front Panel

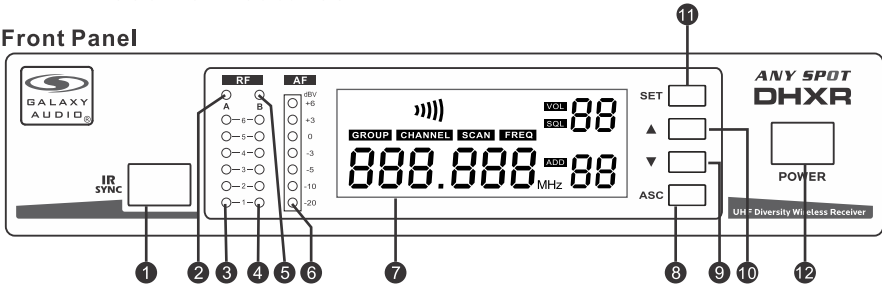

- 1 Infrared (IR) Window.
- 2 Antenna A indicator light.
Indicates when Antenna A is active
- 3 Antenna A RF strength indicator.
- 4 Antenna B RF strength indicator.
- 5 Antenna B indicator light.
Indicates when Antenna B is active.
- 6 Audio Signal Level indicator.
- 7 LCD Screen.
See "DHXR System Setup" on Page 9.
- 8 ASC Sync Button.
Press to initiate IR connection between receiver and transmitter.
- 9 System Menu Down Button.
See "DHXR System Setup" on Page 9.
- 10 System Menu Up Button.
See "DHXR System Setup" on Page 9.
- 11 System Setup Button:
See "DHXR System Setup" on Page 9.
- 12 On/Off Switch.

Rear Panel

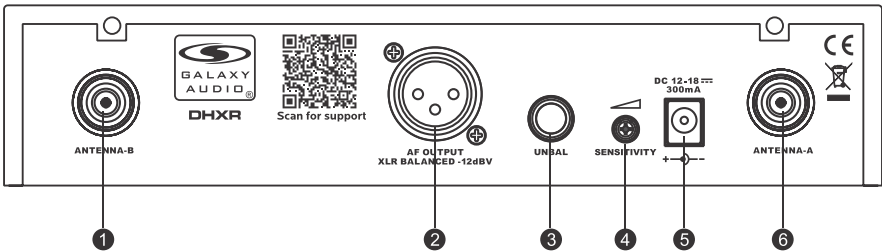

- 1 Antenna Jack B 50Ω.
- 2 XLR Output Jack.
- 3 1/4" Output Jack.
- 4 Mute Threshold Fine Adjustment.
This is set at the factory and usually does not need to be adjusted.
If interference signals are received, this threshold value may be increased by turning the pot clockwise with small screwdriver until the RF signal lamp goes out.
- 5 DC Power Input Connector.
- 6 Antenna Jack A 50Ω.

Functions of the DHXR4 Receiver

DHXR4 Receiver Features

Front Panel

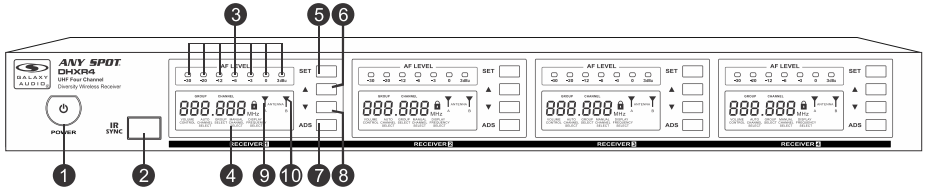

- 1 On/Off Switch
- 2 Infrared (IR) Window
- 3 Audio Level Meter
- 4 LCD Panel
- 5 System Setup Button. Please see "DHXR4 System Setup" on Page 10
- 6 System Menu Up button. Please see "DHXR4 System Setup" on Page 10
- 7 ADS Sync Button
Press to initiate IR connection between Receiver and Transmitter.
- 8 System Menu Down button. Please see "DHXR4 System Setup" on Page 10
- 9 Antenna A Indicator Lights when Antenna A is active.
- 10 Antenna B Indicator Lights when Antenna B is active.

The receiver will switch to whichever Antenna has the best signal.

Rear Panel

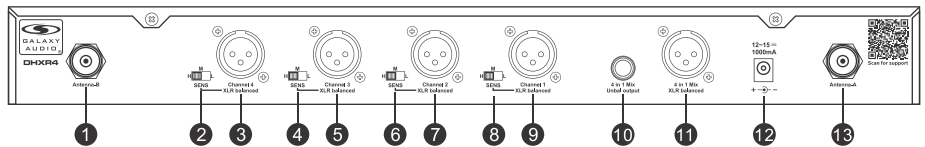

- 1 Antenna Jack B
- 2 Channel 4 Adjustment of Squelch Level
- 3 Channel 4 XLR Output Jack
- 4 Channel 3 Adjustment of Squelch Level
- 5 Channel 3 XLR Output Jack
- 6 Channel 2 Adjustment of Squelch Level
- 7 Channel 2 XLR Output Jack
- 8 Channel 4 Adjustment of Squelch Level
- 9 Channel 1 XLR Output Jack
- 10 1/4" Mix Output Jack
- 11 Balanced Mix Output Jack
- 12 DC Power Input Jack
- 13 Antenna Jack A

The 3 position Sensitivity Adjustment helps to prevent extraneous RF from being picked up and turned into audio when the transmitter is off. The higher level will reduce the useable distance of the transmitter from the receiver. Use the lowest setting that keeps the receiver quiet when the transmitter is off.

The DHXR4 now utilizes Tone Key Squelch. This keeps the receiver channel muted until it receives the inaudible tone from its transmitter. This keeps the channel quiet when the transmitter is off, even if something else is transmitting on the frequency on which the channel is set.

HH65/HH65SC Handheld Transmitter

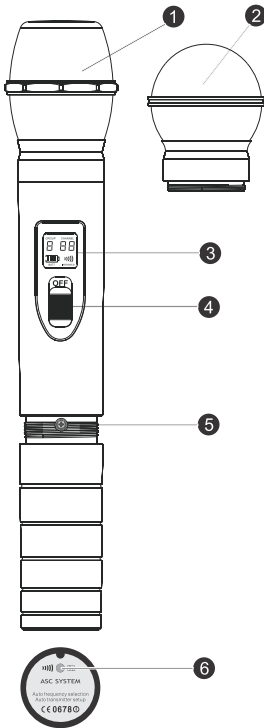

Functions:

- 1 Condenser Mic
- 2 Dynamic Mic
- 3 LCD Screen. Please See the “system setups” on pages 9 or 10.
- 4 Power Switch
- 5 Microphone Input Sensitivity Control.
Left turn for output level decrease, right turn for output level increase.
- 6 IR Port receives infrared beam to synchronize frequencies.



Changing Batteries:

Batteries should be replaced when LCD indicator flashes. Unscrew the battery cover as shown below. Install two AA alkaline batteries, while observing correct polarity indicators in the battery tray. Expected life for two AA alkaline batteries is 8 hours.

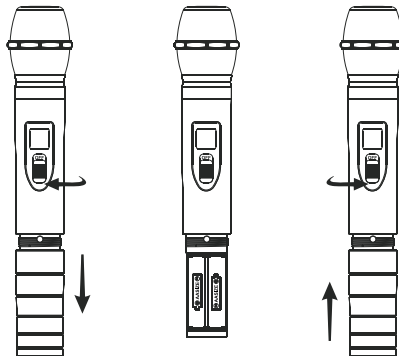

MBP77 Body Pack Transmitter

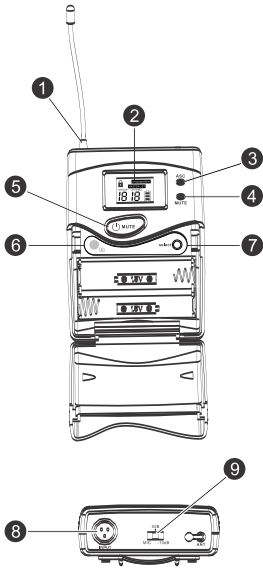

Features

- 1 Antenna.
- 2 LCD panel. Please See the "system setups" on pages 9 or 10.
- 3 Power/ASC/ Low Battery Indicator.
Constant Green: Power ON.
Flashing Green: IR ADS in progress, or Low Batteries.
- 4 Mute Indicator.
Constant Red: Audio Muted.
- 5 Power/Mute Button.
Push and Hold for Power On/Off.
Push once for Mute On/Off.
- 6 IR Window.
Receives IR signals (ADS) to synchronize with Receiver.
- 7 Select Button. Please See the "system setups" on pages 9 or 10.
- 8 3-pin Microphone Input Jack.

Gain Adjustment Switch.

Three gain settings are available. Choose the appropriate setting for your application:

Mic: Microphone

0dB: Guitar with passive pickups

-10dB: Guitar with active pickups,
or Line Level Signals.

Note: To prevent accidental power or mute changes during a performance, you may set the Lock function by a simultaneous press and release of buttons 5 and 7. This will disable all buttons and a "lock" icon will appear in the LCD. Repeat procedure to return to normal operation.

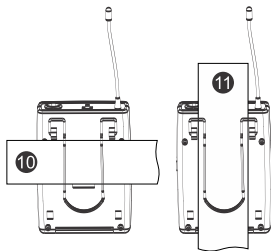

Wearing the Body Pack Transmitter:

Clip the transmitter to a belt **10**. For best results, slide the transmitter down until the belt is pressed against the base of the clip. Or, slide a guitar strap through the transmitter clip **11**, as shown.

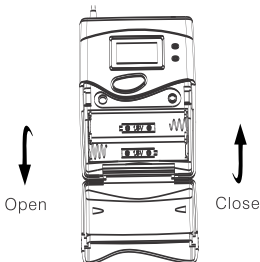

Changing batteries:

Expected life for Two Alkaline batteries is approximately 6 hours. Replace batteries when the Green Power LED and the LCD Battery Indicator (shown below) begin to blink.

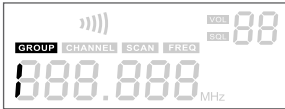

1

Receiver Programming

Group and Channel Selection: Press and Hold the SET button. The Group number will flash. Press ▲ or ▼ to choose the appropriate frequency group, as shown on the left 1; press (SET) again, (CHANNEL) flashes, press ▲ or ▼ to choose the appropriate channel, as shown on the left 2. For best results when operating multiple systems, set all systems to a single group: then set each system to a unique channel within that group.



2

Receiver Volume Setting:

The receiver has an electronic volume control. When in the normal display, press ▲ or ▼ to control the output volume (64 steps total) as 3 shown at left.



3

Normal Display:

Volume and Frequency, as shown at left 4. LED columns to the left of the LCD display show RF & AF Levels.

Automatic Transmitter Setup:

Once the desired channel is set on the Receiver, you may allow the Transmitter channel to be set automatically. Note: only one Transmitter may be used with each Receiver.



4

Turn on the Transmitter. Position the Transmitter IR window directly in front of the Receiver IR window. The IR window of the MBP77 Body Pack is located under the battery door while the IR window of the HH65 Handheld is located at the bottom end of the mic body. Press the ASC Button on the Receiver. The ASC Icon 5 will flash in the Receiver LCD. The RF Meters will light when the synchronisation is complete. The Group and Channel number of the Receiver should now be displayed in the Transmitter LCD. With the HH65, turn on the transmitter after pressing the ASC button.

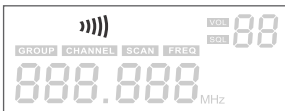

5

Note: The Transmitter must be within half a meter distance from the Receiver during IR ASC automatic channel setting.

Handheld Transmitter Body Pack Transmitter



1

HH65 and MBP77 Transmitter Status Display

Battery Status:

Battery Status Indicators for both the Handheld and Body Pack Transmitters feature Four Level Displays as shown in 1.



2

Group and Channel Display:

After completing the ASC, both the Handheld and Body Pack Transmitters will display the Group and Channel numbers selected as shown in 2.



3

Normal Display:

Both Handheld and Body Pack Transmitters will display Group and Channel numbers as well as Battery Status as shown in 3.

DHXR4 System Setup



1



2



3



4



5

Handheld Transmitter

Body Pack Transmitter



1



2



3



Receiver Programming

Group and Channel Selection:

- 1 Press "SET" button twice, "GROUP SELECT" will display, press ▲ or ▼ to choose the appropriate frequency group.
- 2 Press "SET" again, "MANUAL CHANNEL SELECT" will display, press ▲ or ▼ to choose the appropriate channel.

For best results when operating multiple systems, set all systems to a single group, then set each system to a unique channel within that group. However, depending on the environment, this may not be possible.

Auto Frequency Finder Function on the Receiver:

- 3 Choose "AUTO CHANNEL SELECT" by pressing "SET" once, then press ▲ or ▼. Receiver will automatically find a clear frequency with no interference.

Receiver Volume Setting:

- 4 The receiver has an electronic volume control. Press ▲ or ▼ from the normal display (00 to 63)

Normal Display:

- 5 Frequency and Antenna A or B (when receiving RF).

Transmitting Frequency Automatic Setup:

Place the Transmitter "IR" window to face the Receiver "IR" window. Then press the "ADS" button on the desired Receiver. The Transmitter will automatically match the Receiver frequency.

Attention: The distance between the Receiver and Transmitter IR windows should be less than 0.5m during the ADS IR setup. When setting up multiple Transmitters/Receivers, activate the ADS function of only one Transmitter and Receiver at a time.

MBP77 Transmitter Status Display

Battery Status:

- 1 Battery Status Indicators for both the Handheld and Body Pack Transmitters feature Four Level Displays.

Group and Channel Display:

- 2 After completing the ADS, both the Handheld and Body Pack Transmitters will display the Group and Channel numbers selected.

Normal Display:

- 3 Both Handheld and Body Pack Transmitters will display Group and Channel numbers as well as Battery Status.

Using the auto scan function to find clear frequencies for your DHX or DHXR4 System

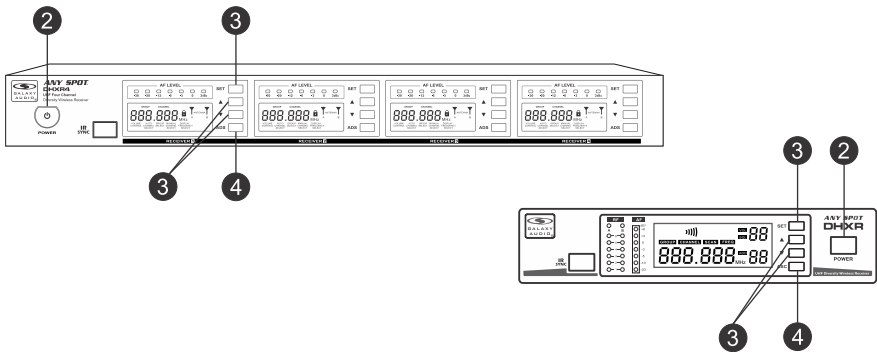

- 1) Power on any pre-existing wireless systems and transmitters (excluding DHXR/DHXR4).
- 2) Power on the DHXR/DHXR4 Receiver, do not turn on the DHXR/DHXR4 transmitters.
- 3) On the DHXR or the first channel of the DHXR4, press the SET button until scan flashes, then press either the up or down button. The receiver will then scan for an open frequency channel within the group selected, and stop on the frequency.

When the DHXR4 Receiver has been set to a clear frequency, use the ADS/ASC feature to sync the receiver frequency to the transmitter.

- 4) Power on the transmitter for the DHXR or the first channel of the DHXR4, and sync it to the receiver using the ADS/ASC feature. Turn the transmitter on and aim its IR window towards the IR SYNC window at the left side of the DHXR/DHXR4, then press the ADS/ASC button on the desired receiver channel, and the transmitter will automatically set to the receiver's frequency.
- 5) For using more channels on the DHXR4, leave the first channel transmitter on and repeat steps 3 and 4 for the second DHXR4 channel.
- 6) Continue this process for the 3rd and 4th channel of the DHXR4.
- 7) If the receiver is unable to find open frequencies on the group selected, you will need to set one or more receiver channels to another group, and then scan again.
- 8) To change the group, press the SET button twice, the group number will begin to flash. Use the up or down button to select another group. Then proceed as before.
- 9) If you have more than one DHXR or DHXR4 system, continue the process as described, adding one channel at a time.

If you have more DHXR or DHXR4 systems to tune follow the same procedure on each one, always leaving the previous system transmitter on.

Troubleshooting

Tips for Improving System Performance

- Maintain a line of sight between transmitters and antennas.
- Avoid placing the receiver near metal surfaces or any digital equipment (CD players, computers, etc).
- Keep the receiver away from the wall and at least 1m from the ground.
- Cellular telephones and two-way radios can interfere with the operation of wireless systems. Do not use these devices in close proximity to the wireless systems.

Troubleshooting

Issue	Indicator Status	Solution
No sound or faint sound.	Transmitter LCD off.	Turn on transmitter. Make sure the batteries are installed correctly.
	Receiver LCD off.	Make sure AC adapter is securely plugged into electrical outlet and into DC input connector on rear panel of receiver.
	Receiver indicates RF.	Increase receiver volume. Make sure Gain adjustment switch on the transmitter is set correctly (applies only to MBP77 Body Pack.)
	Receiver indicates No RF, Transmitter LCD is on.	Make sure Transmitter and Receiver are set to the same frequency. Make sure Transmitter is in range of Receiver. Make sure no large metal objects are near Transmitter or Receiver.
	The battery power indicator light on LCD flashes.	Change the batteries in transmitter.
Distortion or unwanted noise.	Receiver Indicates RF.	Remove nearby sources of RF interference (CD players, computers, in-ear monitor systems, etc.) Use Auto Scan to find a clear Channel
Distortion level increases gradually.	Transmitter power indicator light flashing on the LCD.	Replace Transmitter batteries.
Sound level different from cabled guitar or microphone, or when using different guitars.		Adjust Transmitter Gain and Receiver Volume as necessary.

Systems

Frequency Range: CODE D 584~607 MHz
CODE N 518~535 MHz

Transmitter Output Level: 10 dBm

Band: UHF

Operating Range Under Typical

Conditions: 300'

Note: actual range depends on RF signal absorption, reflection, interference, and battery characteristics.

Audio Frequency Response (+/-3dB):

60Hz~16kHz

Total Harmonic Distortion (+/-30kHz deviation,

1KHz tone): <1%

Dynamic Range: >90dB A-weighted

Operating Temperature Range:

14°F to 122°F (-10° C to +50° C)

Note: battery characteristics may limit this range:

DHXR Receiver:

Audio Output Level (+/-30kHz deviation, 1kHz tone): XLR connector (into 600Ω load) -12dBV ¼" connector (into 3kΩ load) -18dBV

Output Impedance: XLR connector 200Ω

¼" connector 1kΩ

XLR Output: Impedance balanced

Pin1: Ground (cable shield)

Pin2: Audio

Pin3: No Audio

Sensitivity: -93dBm for 30dB

Image Rejection: >90dB

Dimensions: 1.7" x 8.3" x 6.3"

(45 x 212 x 160 mm)(HxWxD)

Weight: 31.75 oz (900 g)

Power Requirements:

12-18 V DC at 1000mA, supplied by external power supply.

DHXR4 Receiver:

Audio Output Level (+/-30kHz deviation, 1kHz tone): XLR connector (into 600Ω load) -12dBV ¼" connector (into 3kΩ load) -18dBV

Output Impedance: XLR connector 200Ω

¼" connector 1kΩ

XLR Output: Impedance balanced

Pin1: Ground (cable shield)

Pin2: Audio

Pin3: No Audio

Sensitivity: -93dBm for 30dB

Image Rejection: >90dB

Dimensions: 1.7" x 16.1" x 11"

(45 x 410 x 280 mm)(HxWxD)

Weight: 7.3 lbs (3.3 kg)

Power Requirements:

12-18 V DC at 1000mA, supplied by external power supply.

Body Pack Transmitter:

Max Audio Input Level:

0 dBV maximum at mic gain position.

+10 dBV maximum at 0 dB gain position.

+20 dBV maximum at 10 dB gain position.

Gain Adjustment Range: 30dB

Input Impedance: 470kΩ

Dimensions: 3.5" x 2.6" x 1"

(89 x 65 x 24 mm)(HxWxD)

Weight: 3.0 oz (85 g) (without batteries)

Power Requirements:

2 "AA" Batteries alkaline or rechargeable batteries

Battery Life:

About 6 hours

Handheld Transmitter:

Max Audio Input Level: 0dBV

Dimensions: 9.5" x 2.1" dia.

(242 x 54 mm dia.)

Weight: 10.6 oz (300 g) (without batteries)

Power Requirements: 2 "AA" size

alkaline or rechargeable batteries

Battery Life: About 6 hours

Accessories and Replacement Parts

Many of these parts and accessories may be found and purchased from the Galaxy Audio website in either the Galaxy Store (www.galaxyaudio.com/parts-and-accessories) or in the accessories tab of each products web page.



AS-EXTBNC - BNC Connector and Cable for front mounting the antennas on the DHX and DHXR4.



AS-ANTBNC - Replacement BNC Antenna for use with Galaxy Audio Wireless Personal Monitors and Wireless Microphones.

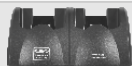

WMC-CGR - DC Charger for HH65, HH65SC, & MBP77. Charges 2 body packs or handhelds at once.



MICCLIPSI - Wireless Microphone Clip



AS-CLIP1576 - Replacement Belt Clip for MBP77



AS-UA12-14.5 - Universal Power Supply for Replacement Power Supply for AS-900, AS-1100, VES, VSC, ECD, ECM, PSE, DHX, DHXR4, & CTS. Includes adapters for most other countries.



PS-13.5-.35.5 - Replacement Power Supply for AS-900, AS-1100, VES, VSC, ECD, ECM, PSE & DHX.

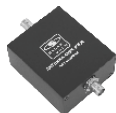

ANT-AMPMIC - Antenna Amplifier utilizes phantom power and a low noise design which covers all UHF frequency points from 500MHz to 900MHz. Metal construction, requires phantom power (9VDC), 50 ohm input/output impedance.



ANT-PDL - Directional antenna used to decrease interference to other equipment. Frequency range 500-900MHz. The UHF wide-band (500-900 MHz) directional LPDA (log periodic dipole array) antenna reduces outside interference while providing increased send/receive signal range. Each antenna paddle is matched to 50 ohms impedance with a low-loss BNC connector; 7dBi gain. For permanent or temporary installation; mounts to 5/8"-27 threads.



ANT-DISTDC - Wireless Microphone Antenna Distribution with Power Distribution for four wireless receiver. Expands wireless microphone systems by splitting one pair of antennas to allow up to four single channel receivers to use the same antennas. Works with PSE, CTS, DHX and DHXR4 series.



MREWD - Replacement Single/Dual Rack Kit for the DHX and most other single space wireless rackmount systems.

DHX & DHXR4 FREQUENCY CHART

D-BAND					AS-1100, DHT, DHX					
Channel	Group 1	Group 2	Group 3	Group 4	Group 5	Group 6	Group 7	Group 8	Group 9	Group 10
1	584.400	585.250	584.200	585.775	585.100	584.425	584.700	585.550	584.500	586.075
2	587.500	586.500	585.675	586.500	587.225	586.400	587.800	586.800	585.975	586.800
3	589.575	588.225	586.800	590.200	588.550	589.425	589.875	588.525	587.100	590.500
4	591.050	590.725	588.450	591.600	590.575	591.475	591.350	591.025	588.750	591.900
5	593.425	592.350	589.750	592.700	592.900	593.775	593.725	592.650	590.050	593.000
6	595.200	593.550	592.200	594.250	596.500	597.675	595.500	593.850	592.500	594.550
7	598.450	597.800	594.325	595.500	597.750	599.800	598.750	598.100	594.525	595.800
8	599.650	598.575	598.225	599.100	599.300	602.250	599.950	598.875	598.525	599.400
9	601.275	600.950	600.525	601.425	600.400	603.550	601.575	601.250	600.825	601.725
10	603.775	602.425	602.575	603.450	601.800	605.200	604.075	602.725	602.875	603.750
11	605.500	604.500	605.600	604.775	603.500	606.325	605.800	604.800	605.900	605.075
12	606.750	607.600	607.575	606.900	606.225	607.800	607.050	607.900	607.875	607.200

N-BAND					AS-1100, DHT, DHX					
Channel	Group 1	Group 2	Group 3	Group 4	Group 5	Group 6	Group 7	Group 8	Group 9	Group 10
1	518.750	518.475	520.175	520.050	523.575	524.075	526.175	526.850	527.075	527.975
2	519.750	519.200	520.700	520.175	524.050	524.275	526.300	527.075	527.750	528.175
3	520.325	519.775	520.800	520.925	524.250	529.300	527.025	528.325	528.675	528.550
4	522.025	520.100	521.600	521.025	524.700	530.025	527.525	530.225	529.025	529.475
5	522.400	521.400	522.250	526.100	524.800	530.125	528.175	530.400	530.475	529.600
6	523.250	521.850	523.125	526.375	526.675	531.275	528.325	530.975	530.850	530.275
7	523.875	522.100	524.125	526.475	527.450	531.400	528.575	531.450	531.750	531.825
8	524.200	522.500	524.825	527.025	527.575	531.825	529.475	532.275	532.850	532.150
9	524.650	523.725	526.200	528.300	527.875	532.200	531.725	532.900	533.300	532.275
10	525.550	524.200	526.750	529.325	529.425	532.900	532.350	533.000	533.550	533.125
11	525.900	524.775	526.875	529.775	529.525	534.675	532.500	533.200	534.075	533.875
12	526.625	525.125	529.050	529.900	529.975	534.950	533.525	533.825	535.100	534.525

DHX & DHXR4
Frequency Chart



<https://www.galaxyaudio.com/assets/uploads/media/MasterFrequency.pdf>

GALAXY AUDIO
Frequency Page



<http://www.galaxyaudio.com/support/schematics-and-frequency-charts>

Wireless Tips

Wireless Tips

Maintain line of sight between the transmitter and receiver antennas.

Do not have walls, metal objects, large crowds, etc. blocking the line of sight between the transmitter and receiver.

Antennas on the stationary equipment should be kept several feet above the ground.

Antennas can be mounted on stands or walls using brackets such as the ANT-LB.

On body pack receivers/transmitters, avoid putting them in your pocket, and/or folding the antenna under the pack. The antenna should hang freely and openly.

Keep the distance between transmitters and receivers as short as possible.

If distances above 20-30' are unavoidable, directional antennas such as the ANT-PDL can improve reception by rejecting signals outside their pickup angle.

Find out what TV stations are broadcasting in your area and avoid the channels they are on.

This information is available from many sources on line, such as www.tvfool.com.

If your receiver is showing that it is receiving RF when your transmitter is turned off, you need to move to another frequency.

If you are using several systems, you can contact service@galaxyaudio.com for assistance in frequency coordination.

Make certain you are using fresh batteries, rechargeable batteries may be used, but they discharge at a much faster rate than alkaline.

DTV Frequency Ranges & FCC Consumer Alert

DTV RF Channel	Frequency Range
14	470-476
15	476-482
16	482-488
17	488-494
18	494-500
19	500-506
20	506-512
21	512-518
22	518-524
23	524-530
24	530-536
25	536-542
26	542-548
27	548-554
28	554-560
29	560-566
30	566-572
31	572-578
32	578-584
33	584-590
34	590-596
35	596-602
36	602-608
37	608-614
38	614-620
39	620-626
40	626-632
41	632-638
42	638-644
43	644-650
44	650-656
45	656-662
46	662-668
47	668-674
48	674-680
49	680-686
50	686-692
51	692-698

The frequencies of the Galaxy UHF Wireless Systems are on frequencies that are used by Digital Television stations.

To be assured of the best performance, you should determine on what RF channels the DTV stations in your area are broadcasting, then set your wireless systems on frequencies that are not being used.

You can find that information on this FCC web site.

<https://www.fcc.gov/media/engineering/dtvmaps>

Enter the zip code of the location where the wireless system will be used into the location search bar. A list of stations in that area will be listed. Click on the call sign of the stations and the details will appear, showing you the RF channel the TV station is using. Compare these with the chart to the left, and using the Galaxy frequency charts on page 16, find a frequency that is not on an active DTV RF channel.

For example, if you have an L-Band DHXR and your location has DTV stations on RF channels 45 and 48, you will want to set your DHXR on a frequency that is on RF channel 46 or 47.

FCC Consumer Alert for Wireless Microphones (U.S.)

Most users do not need a license to operate this wireless microphone system. Nevertheless, operating this microphone system without a license is subject to certain restrictions: the system may not cause harmful interference; it must operate at a low power level (not in excess of 50 milliwatts); and it has no protection from interference received from any other device. Purchasers should also be aware that the FCC is currently evaluating use of wireless microphone systems, and these rules are subject to change.

For more information, call the FCC at 1-888-CALL-FCC (TTY: 1-888-TELL-FCC) or visit the FCC's wireless microphone website at www.fcc.gov/cgb/wirelessmicrophones

Please visit galaxyaudio.com for the latest updates



MAKERS OF THE ORIGINAL
HOT SPOT PERSONAL MONITOR



www.galaxyaudio.com

THREE YEAR LIMITED WARRANTY

WARRANTY Information can be viewed online at
<http://www.galaxyaudio.com/support/warranty>



www.galaxyaudio.com/support/warranty

DHX & DHXR4 USER'S MANUAL

Specifications in this manual are subject to change without notice.
For the most up to date manual and information
visit www.galaxyaudio.com.

1-800-369-7768 www.galaxyaudio.com

© Copyright Galaxy Audio 2019