

## Push-Lite® SWITCHES AND INDICATORS OUTLINE DIMENSIONS

### SWITCH AND INDICATOR MOUNTING WITH BARRIERS (See Note)

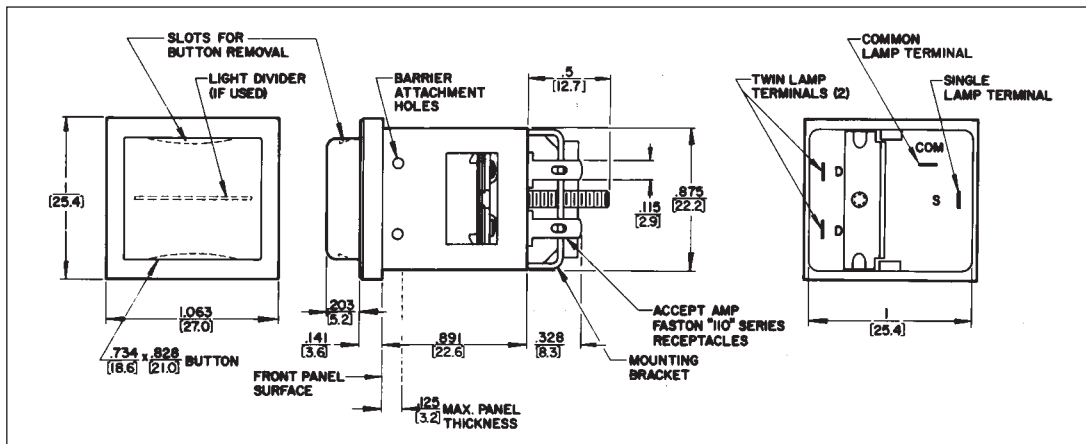

### SWITCH AND INDICATOR MOUNTING WITH BARRIERS (See Note)

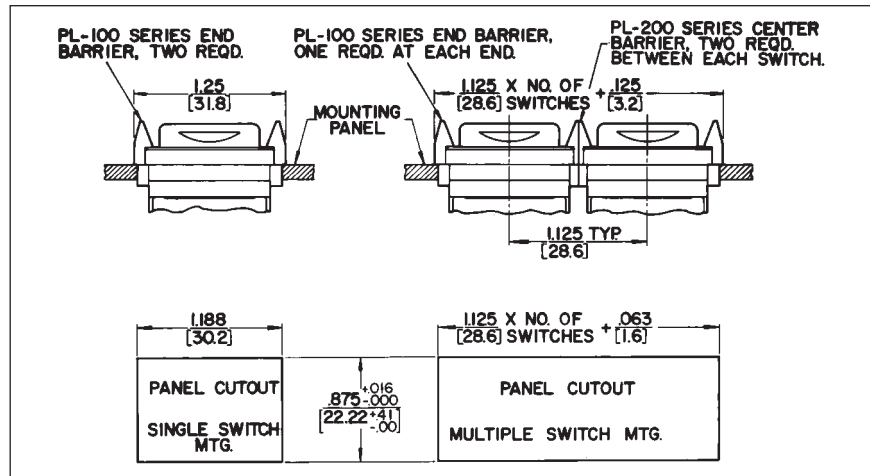
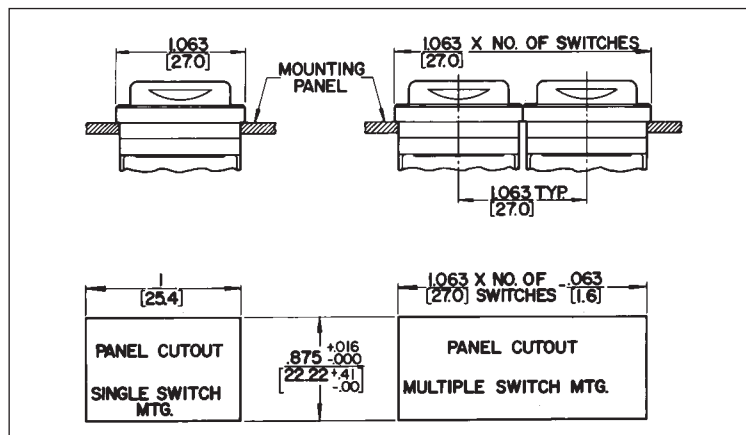

#### NOTE: PANEL OPENINGS FORM MULTIPLE ROW SWITCH MOUNTING

Leave .109 Inch (2.77 mm) minimum width strip between panel-cutouts to assure secure mechanical mounting of adjacent clamp mounting brackets.

DIMENSIONS ARE FOR REFERENCE ONLY  $\frac{\text{Inch}}{\text{(mm)}}$

NOTE: Contact your Switchcraft Representative for price and delivery.