

### General Description

The Rane MP 24z Mixer is the standard for night club mixers. Following the advice of the most renowned figures in the night club market, Rane developed the MP 24z to break down the limiting barriers of previous mixer designs.

Featuring four Stereo Input mixing Channels, each supplied with a selection of several Phono and Line Inputs, the MP 24z easily suits the needs of the most complex audio/video installations. A total of six Stereo Line Inputs are available plus three Stereo Phono Inputs.

The Mic Control section of the MP 24z handles two microphones simultaneously. Both mics may be contoured by the three-band Mic Equalizer as well as processed through a Mic Loop jack. On the rear of the unit, an XLR low-Z Main Mic Input with switchable Phantom Power, and a 1/4" hi-Z Aux Mic Input are both mixable.

The Output section of the MP 24z provides a Master Level fader, four band Program Equalizer (independent of the Microphone EQ), two auxiliary output controls (Zone and Booth), a stereo 12-segment Peak Program Meter and full Headphone Control monitoring and cueing system.

The rear of the MP 24z, besides holding all of the normal Input and Output connectors, features a transformer isolated Light Control Output with associated Level control, balanced XLR Main Outputs, Program Equalizer EQ Range switch ( $\pm 4$

dB or  $\pm 8$  dB) and a System Mono switch.

All sliders on the MP 24z are studio-quality faders as found on high quality audio mixing consoles.

**New features** have been added to the MP 24z. *Active Crossfader™* technology combines state of the art voltage controlled amplifier design with a professional quality crossfader control. This combination sets new standards for performance, reliability and serviceability. Virtually all crossfader noise is eliminated. Channel to channel crosstalk is greatly reduced and the *off* isolation of the faded channel is greatly increased. *Active Crossfader* technology dramatically increases the service life of the crossfader. In the unlikely event of crossfader failure, there is no loss of signal. If a crossfader becomes rough or noisy, it may be "hot-swapped" during a performance *with no interruption of the audio signal*. Simply use the input faders to set the audio levels while the crossfader is out of service.

Each of the Phono Inputs can be converted to Line Inputs by moving internal jumpers. Another internal jumper allows defeating the Booth Ducker circuit when the mic is activated—this feature has been requested by those wishing to use the Booth Output as a second record output or second zone. Another jumper allows the Mic section to be mixed to the Tape Outs—the default setting is "music only".

### Features

- *New! 'Dipless' 60mm Crossfader; Optional 45mm Crossfader*
- Front Panel Replaceable *Active Crossover™*
- Four Stereo Input Mixing Channels
- Six Stereo Line Inputs & Three Stereo Phono Inputs
- Two Mic Inputs with Three-Band EQ
- Mic & Two Program Effects Loops
- Headphone Cueing
- Four Band Program EQ
- Balanced XLR Master Output
- Two Auxiliary Outputs
- Isolated Light Control Output
- Phono Inputs Convertible to Line
- Switchable Booth Ducker
- UL/CSA/CE and 100/120/230 VAC Remote Power Supplies

Parameter	Specification	Limit	Units	Conditions/Comments
Input Impedance: Phono	47.5k (shunted by 200 pF)	1%	ohms	
.....Line, Effects Returns	20k	1%	ohms	
.....Main Mic, Loop	1k	1%	ohms	
.....Aux Mic	100k	1%	ohms	
Max Input Level: Line	22	1	dBu	
.....Phono (1 kHz)	180	5%	mV	
.....Main Mic	+17 (-15.5)	1	dBu	Min Gain (Max Gain)
.....Aux Mic	+3.5 (-38)	1	dBu	Min Gain (Max Gain)
Output Impedance: Main	600 Bal. (300 unbalanced)	1%	ohms	300 ohms each leg to ground
.....Zone, Booth, Light	100	5%	ohms	
.....Loop, Tape	10	5%	ohms	
.....Effects Send	10 (230)	5%	ohms	Stereo (Mono)
.....Headphone	0.8	max	ohms	
Max Output Level: All	+28 (+22)	1	dBu	Balanced (Unbalanced) >2k ohms
Infrasonic Filter	15 Hz, 18 dB/oct	3%	Hz	Butterworth
Ultrasonic Filter	30 kHz, 12 dB/oct	3%	Hz	
Frequency Response	15 Hz-30 kHz	+0/-3	dB	
THD+Noise	0.1	typ	%	+4 dBu, 20-20 kHz, any In, any Out
Signal-to-Noise Ratio				re +4 dBu, 20 kHz noise bandwidth
.....Phono to Tape	91	1	dB	Input fader Max
.....Phono to Master/Zone/Booth	90 (71)	1	dB	Main fader unity (Max)
.....Line to Master/Zone/Booth	94 (76)	1	dB	Main fader unity (Max)
.....Main Mic	123	1	dB	Equivalent input noise
RIAA Phono Stages	Equalization accuracy:0.1	typ	dB	
Crosstalk	-60	max	dB	Channel to channel, 1 kHz
Program Equalizer: Bass	Shelving @ 100	5%	Hz	
.....Mid	Peaking @ 1.6k	5%	Hz	
.....Hi-Mid	Peaking @ 4.0k	5%	Hz	
.....Treble	Shelving @ 10k	5%	Hz	
.....Range	±8 or ±4	1	dB	Switch selectable
Microphone Equalizer: Bass	Shelving @ 100	5%	Hz	
.....Mid	Peaking @ 1k	5%	Hz	
.....Treble	Shelving @ 10k	5%	Hz	
.....Range	±10 Bass & Treble; ±9 Mid	1	dB	
Unit: Agency Listing				
.....120 VAC model	Class 2 Equipment U.L. 813 Exempt CSA Exempt			National Electrical Code Class 2 Class 2
.....230 VAC model	VDE, SELV CE (EMC) CE (safety) Exempt			Safety extra low voltage EMC directive 89/336/EEC Article 1 of LVD 73/23/EEC
Power Supply: Agency Listing				
.....120 VAC model	UL listed CSA Certified			Class 2 equipment File no. E88261 File no. LR58948
.....230 VAC model	CE (EMC) CE (safety)			Meets EMC directive 89/336/EEC LV directive 73/23/EEC
Power Supply Requirement	18 VAC w/ center tap			RS 1 (see data sheet)
Maximum Current	750		mA	RMS current from remote supply
Unit Construction	All Steel			
.....Size	7"H x 19"W x 5.3"D (4U)			(17.8 cm x 48.3 cm x 13.5 cm)
.....Weight	11 lb			(5.0 kg)
Shipping: Size	11" x 23" x 16"			(27.9 cm x 58.4 cm x 40.6 cm)
.....Weight	18 lb			(8.1 kg)
Note: 0 dBu=0.775 Vrms				

## Block Diagram

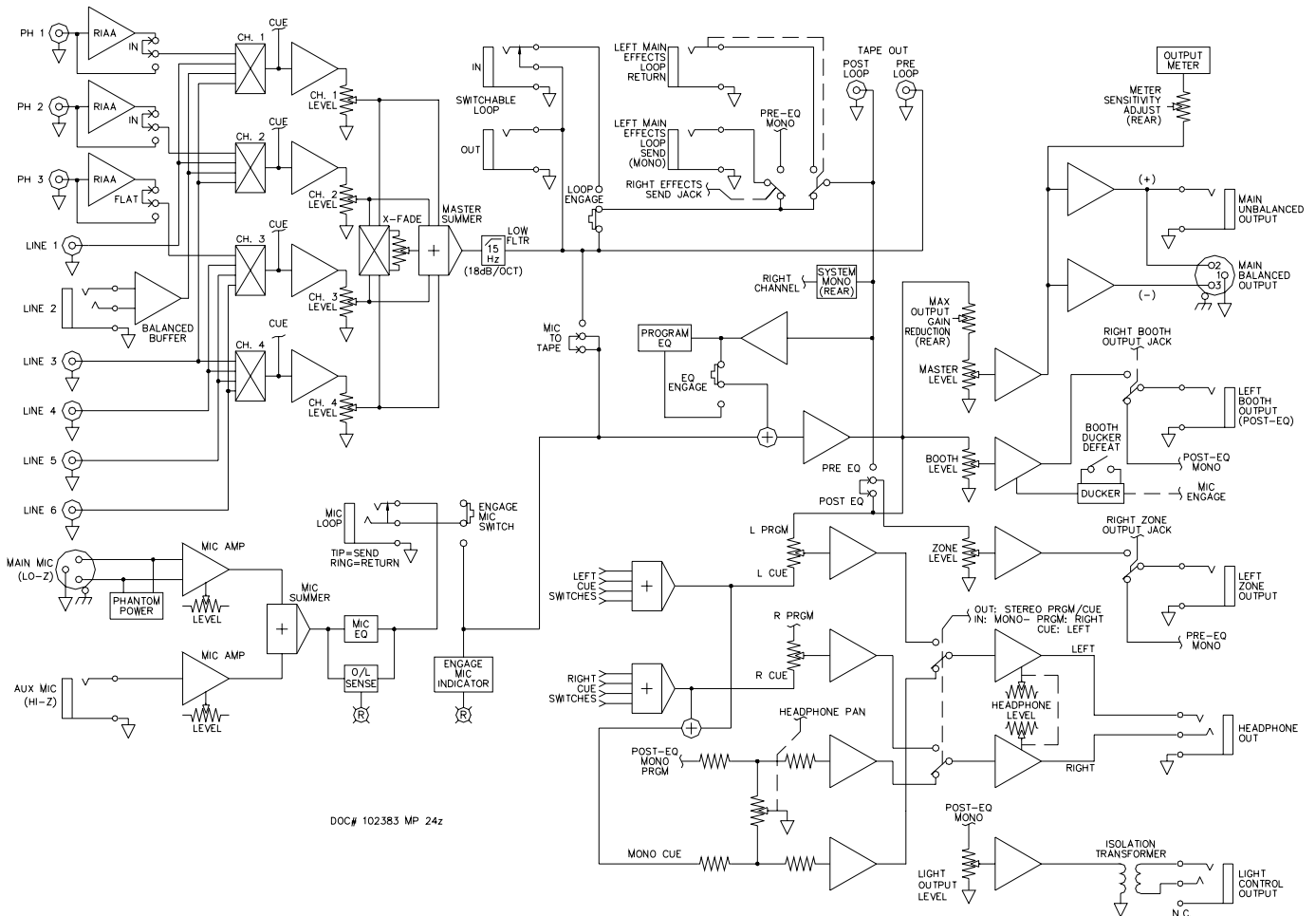

## Application Information

*Extreme care must be taken when installing the MP 24z. So many pieces of equipment all connect to the MP 24z that if proper interconnection wiring is not done, many problems occur. Our technical service people spend the majority of their MP 24z time in just unraveling improperly wired systems. Everything from bad RCA cables (common) to incorrectly grounded cables (very common) cause unnecessary complaints. Also, many units returned for noisy LOOP related problems turn out to be problems with the unit installed in the loop — not with the MP 24z.*

Here are a few of the important user details of the MP 24z:

The Master Level control on the front goes to 10. But what 10 means is determined by the Max Output Gain Reduction control on the rear (out of the way of inquisitive fingers). You limit the max gain, hence, the max output, using

this control. This allows the MP 24z to be operated at compatible maximum levels for the system power amps.

Likewise, the Peak Program Meters are calibrated by the rear mounted Meter Sensitivity Adjust control. Output levels ranging from 0.6V to 10V may be set to indicate full scale on the Meters. Once calibrated, this means when all LEDs are lit you know the system is, in fact, at maximum level.

The labeling on the Program Equalizer control knobs indicate Max or Min at their extremes. What this means is again determined by a switch on the rear panel. You have two choices:  $\pm 4$  dB or  $\pm 8$  dB. Both modest amounts. You determine what the system allows in the way of maximum added EQ and set it. The operator is happy because they can rotate the pots to their extremes, and you are happy because you know this cannot destroy anything. Everybody wins with an MP 24z.

Rear Panel

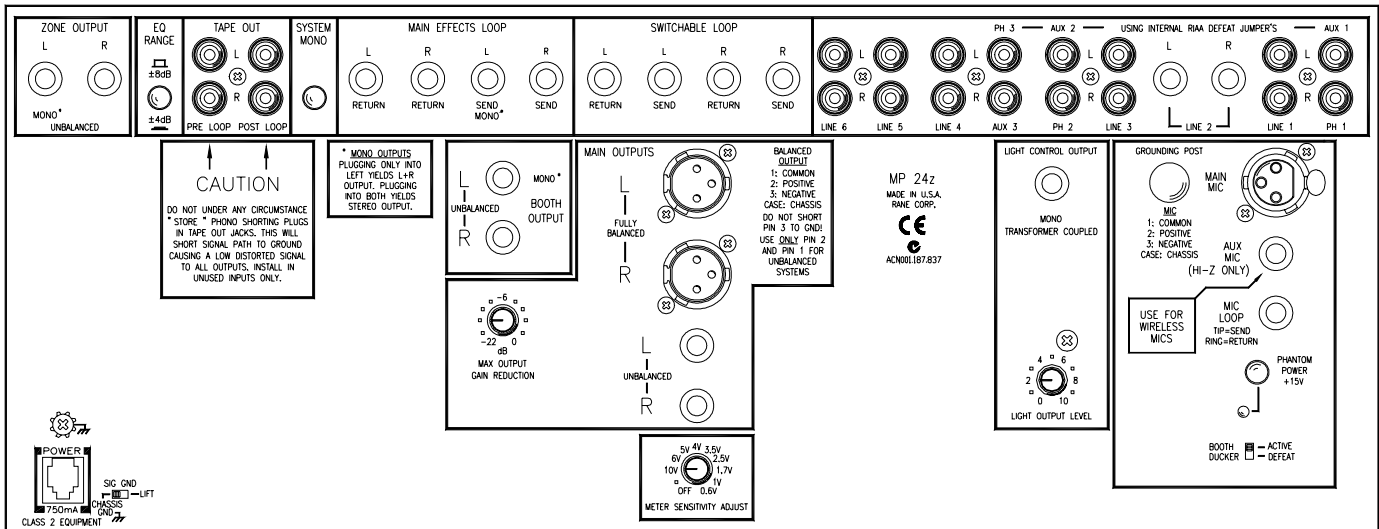

Architectural Specifications

The mixer shall have four (4) stereo mixing buses, each equipped with studio quality 60mm faders. Fully programmable smooth and silent active crossfading between any two of the input channels shall be included. There shall be three (3) stereo phono inputs and six (6) stereo line level auxiliary inputs. Provisions shall exist for simultaneous use of two microphones, with separate 3-band equalization and external processing loop. Two effects loops shall be provided with front panel control of one. Program equalization shall be provided with a 4-band equalizer. Separate Booth and Zone stereo outputs shall be provided with individual level con-

trols. A transformer isolated light trigger output with level control shall be included. Program metering shall be via a stereo (12) segment LED meter. Complete cueing and headphone monitoring system shall be built-in.

RFI filters shall be provided. Infrasonic and ultrasonic filters shall be built-in.

The unit shall be capable of operation by means of an external safety extra low voltage power supply connected to 120 VAC (240 VAC where applicable). The unit and the power supply shall be CE certified. The unit shall be entirely constructed from cold-rolled steel.

*The unit shall be a Rane Corporation Model MP 24z.*

Accessories

- F 45 Fader Kit - 45 mm Crossfader Replacement
- F 60 Fader Kit - 60 mm Crossfader Replacement