

General Description

The SRM 66 provides a cost effective solution for systems requiring any combination of zone distribution, room combining, and remote level control. Split, route, and mix functions are implemented with a six input, six output matrix mixer. The SRM 66 allows independent routing and mix-level adjustment of any Input to any Output.

Control consists of a backlit LCD, five buttons and a Data wheel. All programming is accomplished using 11 easily accessible edit pages. Six pages control Output programming, four for Group programming and one for Memory functions.

Inputs and Outputs are line-level balanced and equipped with Euroblock connectors. Rear panel Gain switches on each Input and Output allow -10 dBV or +4 dBu sensitivity. Front panel Mix Input Headroom LEDs indicate the remaining headroom for each of the six inputs at 4 dB and 16 dB.

Programmable Limiters on each Output prevent mixer overload. If Output level exceeds the Limit Threshold, all six mix levels for the given Output are reduced, thus maintaining the proper mix.

Each Output features an internally switchable 2nd-order 80 Hz Highpass filter. These filters are useful in conjunction with constant-voltage line transformers or small sound-reinforcement speakers.

The SRM 66 uses Output Groups to “link” attenuation levels and Limiter gain reduction of one or more Outputs. Outputs may be assigned to one of six Output Groups. For example, a stereo Output pair would typically be assigned to the same Output Group. This ensures that they limit together and are controlled by a common Output Group attenuation or Remote. Output Group Levels are the only parameters *not* affected by Memory changes.

Outputs are assigned to any one of the six possible Output Groups or none. Remotes are then assigned to any one of the six possible Output Groups or to the Master Group. The Master Group is configured by assigning any number of the six possible Groups to the Master Remote. For example, say you have a six zone system and have a Remote assigned to control the level in each zone. You can then assign any

number of the Output Groups to the Master Remote, allowing all zones to be controlled by one Remote.

Mix configurations are saved in up to 24 Memories. These non-volatile Memories are stored in EEPROM, requiring no batteries. Memories may be recalled via the front panel LCD screen or the rear panel Memory Recall Port (MRP). The MRP allows remote contact closures to recall any of the 24 Memories. Advanced MRP users can completely program the MRP closure-to-memory-mapping functions via SRM Exchange software (see RaneNote 142).

The SRM 66 provides a Remote Interface Port (RIP) which supports up to seven optional SR 1L “Smart” digital Remote controls. Each Remote may be assigned to any one of the six possible Output Groups or to the Master Group. The Remotes control the level of a Output Group, not Output level. Each of the 24 Memories stored in the SRM 66 may have unique Output Group assignments for Outputs and SR 1L Remotes. This allows flexible room combining and system reconfiguration. All remote devices assigned to a Output Group display the level of the Output Group. The Remote Interface Port is a powered, half duplex, (RS-485) party line system using 5 wires, allowing any combination of “star” and/or “chained” wiring. The SR 1L also supports encoder lockout and Master/Slave functionality where one remote controls Output Groups across multiple SRM 66s. (See the SR 1L Data Sheet and RaneNote 142.)

The FP Lock function locks out all front panel SRM 66 control except for Output Group Levels and Memory Recall. The SR 1L Remotes can still control Output Group Levels with the FP Lock rear panel switch engaged. With FP Lock, all edit pages are viewable, but not changeable.

Complete programmability of the MRP is possible using the *SRM Exchange* software included with the Rane DSC 1 accessory (see the DSC 1 Data Sheet and RaneNote 142).

The SRM 66 and SR 1Ls can be controlled via AMX or Crestron room controllers using the SRM 66’s (RS-485) Remote Interface Port (see RaneNotes 138 & 139). All RaneNotes are available at www.rane.com.

Features

- **NEW!** Master Group Level Capability (remote optional)
- **NEW!** Up to Seven SR 1L Digital Remotes (optional)
- 6 Inputs Split, Route and/or Mix to 6 Outputs
- Programmable Input Mix & Output Level Controls & Limiters
- Programmable Output & Remote Output Group Assignments
- 24 Non-Volatile EEPROM Memories with Remote Recall
- Balanced Euroblock Input and Output Connectors
- UL/CSA/CE Remote Power Supply

Applications

- Programmable Split, Route, Mix and/or Level control
 - Via contact closure, front panel LCD or AMX/Crestron room controllers (RS-485)
- Room Combining
 - Stand alone or with room control (AMX/Crestron)
- Remote Level Control for multi-zone applications
 - One to six remotes can control many fluctuating zones
- Pro & Consumer Voltage Friendly

Parameter	Specification	Limit	Units	Conditions/Comments
Inputs: Type	Active Balanced			
.....Connectors	Euroblock			
.....Impedance	20k	1%	ohms	
.....Maximum Level	+14	1	dBu	-10 dBV gain
	+26	1	dBu	+4 dBu gain
.....Mix Range	+6 to -25 and Off		dB	1 dB steps
Outputs: Type	Active Balanced			
.....Connectors	Euroblock			
.....Impedance	200	1%	ohms	
.....Maximum Level	+8	1	dBu	2k ohm load, -10 dBV gain
	+20	1	dBu	2k ohm load, +4 dBu gain
.....Master Level Range	+0 to -59 and Off		dB	1 dB steps
Control Group Attenuation	+0 to -29 and Off		dB	1 dB steps
Limiter: Threshold Range	0 (Max) to -28		dB	relative to max. sig. level, 1 dB steps
.....Attack Time	150		ms	10 dB step
.....Release Time	500		ms	10 dB step
High Pass Filter (switchable)	80	3%	Hz	2nd order, 12 dB/octave, Butterworth
RFI Filters	Yes			
Mix Input Headroom Meter	+4 & +16	2	dB	Headroom remaining before clip
Frequency Response	10-25 kHz	typ.	dB	-10 dBV gain
	10-40 kHz	typ.	dB	+4 dBu gain
THD+Noise	<0.1%	.05	%	+4 dBu, 20-20 kHz (80 kHz BW)
Signal-to-Noise Ratio		20 kHz noise BW, unity gain, one Channel, re: +4 dBu		
	90	2	dB	-10 dBV gain input & output
	80	2	dB	+4 dBu gain input & output
Off Isolation	>80	min.	dB	@ 1 kHz, re: +4 dBu
Unit: Agency Listing				
.....120 VAC model	Class 2 equipment			National Electrical Code
	U.L. 813			Exempt Class 2 equipment
	CSA			Exempt Class 2 equipment
.....230 VAC model	CE (EMC)			EMC directive 89/336/EEC
	CE (safety) Exempt			Exempt per article 1, LVD 73/23/EEC
Power Supply: Agency Listing				
.....120 VAC model	UL			File no. E88261
	CSA			File no. LR58948
.....230 VAC model	CE-EMC			EMC directive 89/336/EEC
	CE-Safety			LV directive 73/23/EEC
Power Supply Requirement	18 VAC w/center tap	10%	Vrms	
Maximum Current	300		mA	RMS Current from Remote Supply
Unit: Construction	All Steel			19" 1U Rackmount
.....Size	1.75" H x 19" W x 8.5" D (1U)			(4.4 cm x 48.3 cm x 21.6 cm)
.....Weight	5 lb (w/o power supply)			(2.3 kg)
Shipping: Size	4.25" x 20.3" x 13.75"			(11 cm x 52 cm x 35 cm)
.....Weight	9 lb			(4.1 kg)
<i>Note: 0 dBu=0.775 Vrms</i>				

SRM 66 Block Diagram

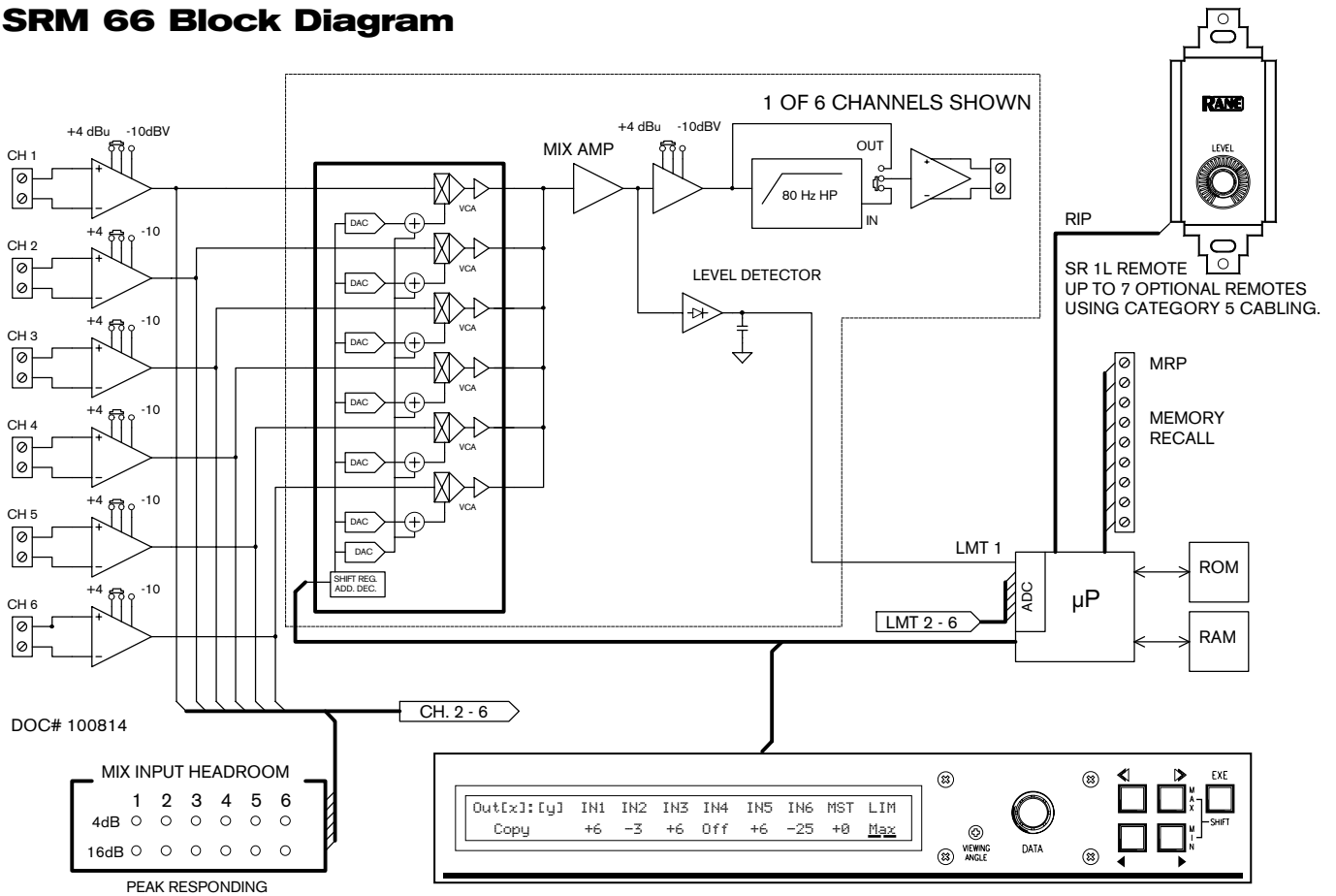

SRM 66 Output Page

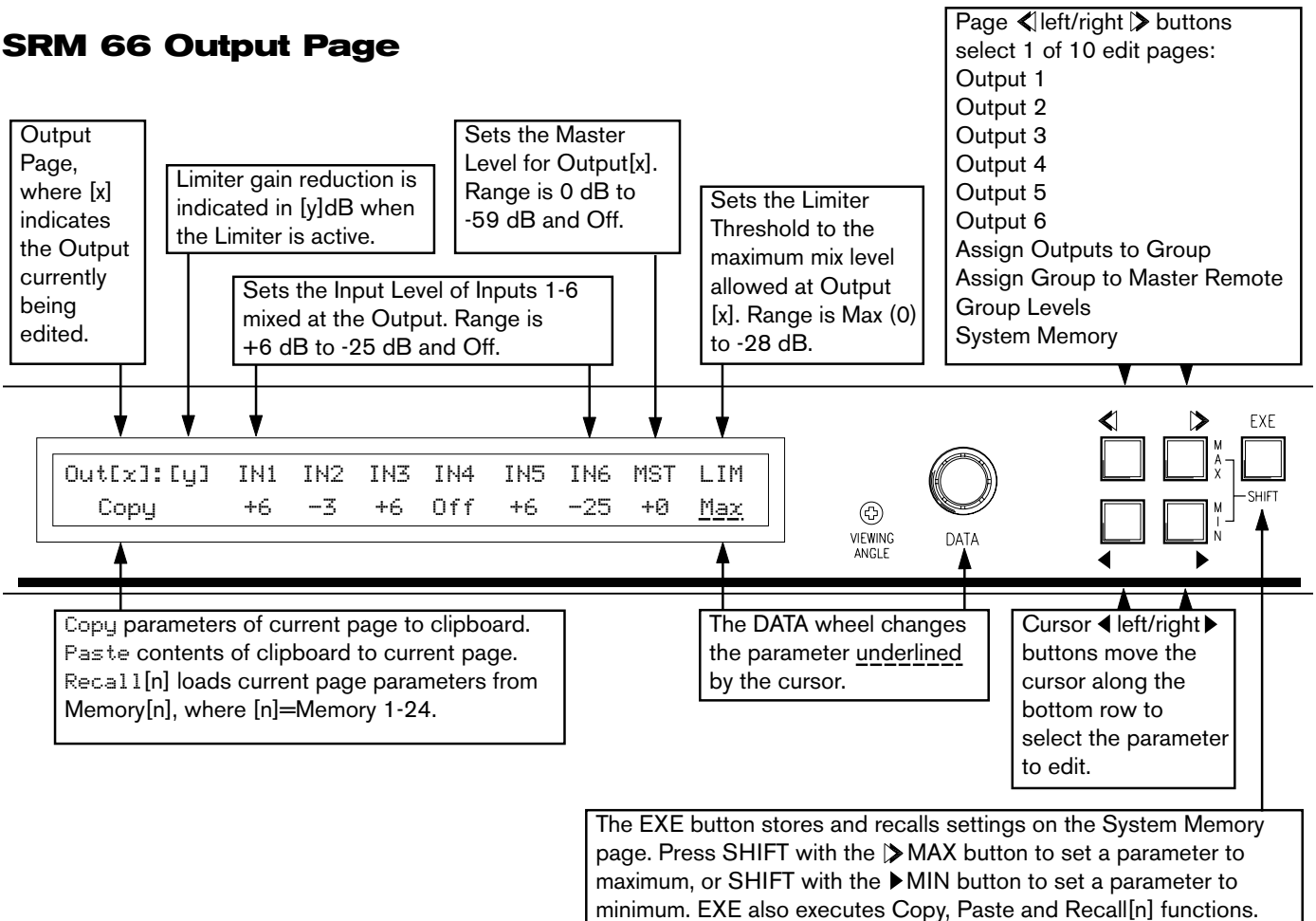

Rear Panel

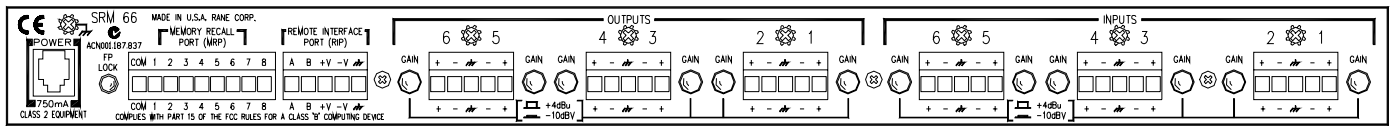

Architectural Specifications

The unit shall have six (6) mono inputs and six (6) mono outputs. The unit shall be capable of simultaneously splitting, routing and/or mixing any input to any output. Each output shall have six input mix level controls with a range of +6 dB to -25 dB, in 1 dB steps, or off. A master output mix level shall have a level control with a range of +0 dB to -59 dB, in 1 dB steps, or off.

Input headroom meters shall be provided for each of the six inputs by means of front panel LEDs.

Programming shall be accomplished via the front panel backlit LCD display and five (5) momentary buttons with a data wheel. An adjustment for LCD viewing angle shall be provided.

Limiters shall be provided on each output. The limit threshold shall be adjustable in 1 dB steps from 0 dB (Max) to -28 dB re: clip.

An 80 Hz high-pass filter shall be provided on each output. This filter shall be bypassable with an internal switch.

Provisions to link attenuation level and limiter gain reduction of output combinations shall be provided in the form of Output Groups.

A Remote Interface Port shall be provided permitting the use of up to seven (7) SR 1L Smart digital Remote controls for the purpose of adjusting Output Groups from a remote location. Each SR 1L remote shall install into a standard US electrical box at least 2¼ inches deep.

A memory recall port shall be provided to recall any memory via contact closure.

The inputs and outputs shall be line-level, active balanced designs terminated with Euroblock connectors. RFI filters shall be provided.

The unit shall be exempt from agency safety requirements and powered from a UL listed / cUL certified remote power supply (120 VAC), or meeting CE requirements (230 VAC).

The unit chassis shall be constructed entirely from cold-rolled steel, and mount into a standard 1U EIA rack.

The unit shall be a Rane Corporation SRM 66 Splitter Router Mixer.

SR 1L Smart Remote (Accessory)

The Rane SR 1L Smart digital Remote provides remote level control for one Output Group of an SRM 66. The SR 1L has 31 LEDs to indicate the Output Group’s current setting of 0 to 29 dB of attenuation (in 1 dB steps) and OFF. *Note that the Remotes control the level of a Output Group, not the level of an Output.* It was designed to be mounted in a standard U.S. electrical box with a minimum depth of 2-¼ inches, and can be covered with a standard Decora™ plate cover.

Up to seven SR 1Ls can be connected to a single SRM 66. Each SR 1L must be set to a unique address (1-7). The SRM 66 can assign multiple Remotes to a single Output Group. Multiple Output Groups may be assigned to the Master Remote (address 7). If the Output Group’s value is altered via the SRM 66’s front panel or any other SR 1L, every Remote mapped to that Output Group is updated to reflect the new setting. SR 1L rotary encoder can be lockout (disabled) using an external contact closure, although the attenuation indicator continues to display the proper Output Group level.

The SR 1L replaces and is backwards compatible with the SR 1. See the SR 1L Data Sheet for dimensions and more information.

Decora is a registered trademark of Leviton.

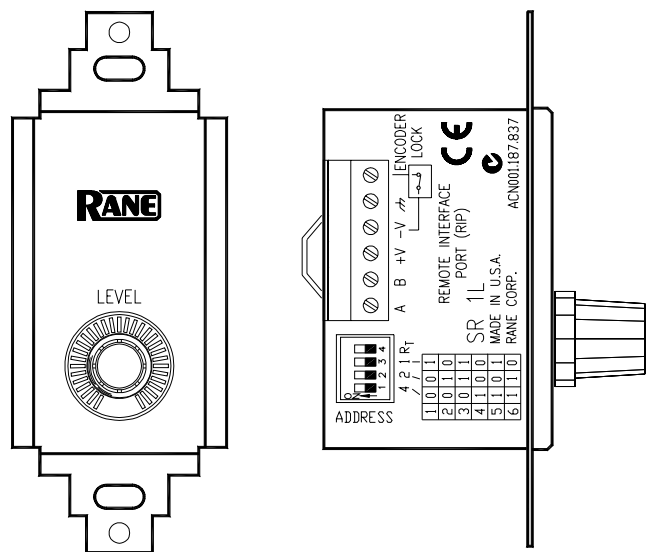

Additional Reading

1. RaneNote 138, “Using a Control System with an SRM 66”
2. RaneNote 139, “Using SR 1L’s with other Rane Products”
3. RaneNote 142, “Advanced Applications of the Ingenious SRM 66 and SR 1L”