

0102 - SURFACE MOUNTED SPEAKER SYSTEMS

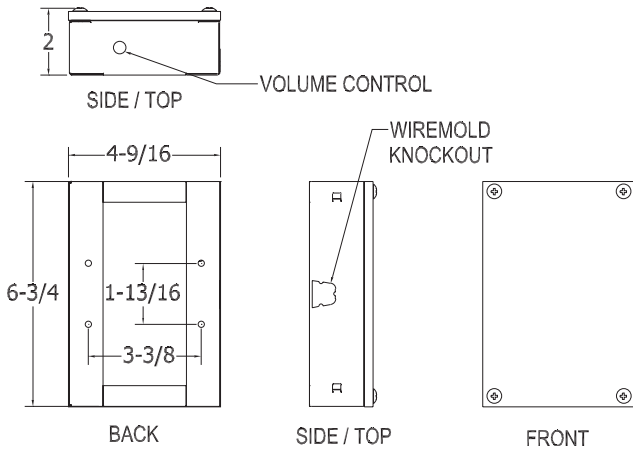

GENERAL DESCRIPTION

The Quam SYSTEM 10/VC is a complete loudspeaker assembly, with 4" frame loudspeaker, 25 and 70.7V universal transformer, volume control, charcoal gray cloth baffle and CRS enclosure. Finish: Black baked epoxy hybrid.

INTENDED USE

Surface mount in an indoor environment.
Program Material: Signal tones, voice and music

SYSTEM COMPONENTS

Loudspeaker	4C3PA
Transformer	TBLU (5W - 25 and 70.7V, 5 taps at -3 dB levels)
Baffle / Enclosure	SYSTEM 10/VC
Attenuator	Model VC - Continuous Attenuator

RECOMMENDED ADDITIONAL QUAM COMPONENTS

None required

AUDIO SPECIFICATIONS

Speaker Size	4" Frame
Average Sensitivity	96 dB SPL, 1W / 1M
Power Rating	10W RMS, EIA 426A Standard
Calculated Output	103 dB SPL, 5W / 1M
Frequency Response	180 Hz - 10 kHz EIA 426A Standard
Nominal Coverage Angle	90° Included Angle, -6 dB / 2 kHz, Half Space
Audio Connection	7" Long Tinned Wires, Pre-cut

Recommended construction sequences, installation instructions and A&E Specifications are available in various formats on the Quam Architects' and Engineers' Resources CD or on the web at www.quamspeakers.com

Quam-Nichols Company

234 East Marquette Road, Chicago, IL 60637
 Phone (800) NEED NOW Fax (888) NEED NOW
 (800) 633-3669 (888) 633-3669
 E-Mail: neednow@qnc.com www.quamspeakers.com

