



Quam

PS6L

1-Gang, Six-Position Program Selector

PS6L/QC10

2-Gang, Six-Position Program Selector with Volume Control

0503 - SELECTORS, SWITCHES, VOLUME CONTROL

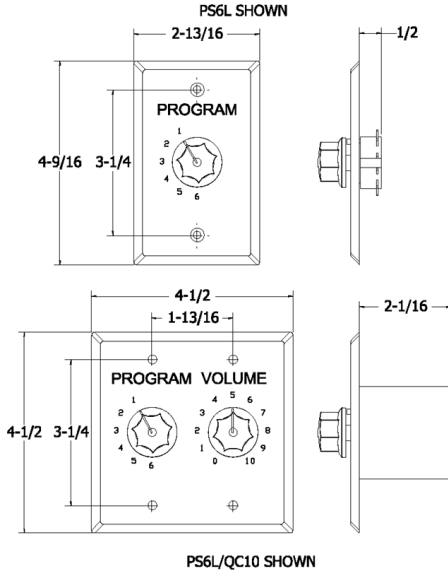

GENERAL DESCRIPTION

The Quam PS6L is a single gang, six-position program selector that assigns the balanced output of a 25, 70.7 or 100V amplifier to one or more loudspeakers with a total load of 60W or less.

The Quam PS6L/QC10 is a 2-gang assembly with six-position program selector that assigns the balanced output of a 25, 70.7 or 100V amplifier to one or more loudspeakers with a total load of 20W or less and a continuous rotary ten-step audio level attenuator.

Finish: Brushed stainless faceplate, black printed legend, black knob, white indicator hash mark

INTENDED USE

Indoor environment
Program Material: Signal tones, voice and music.

SYSTEM COMPONENTS

N/A

RECOMMENDED ADDITIONAL QUAM COMPONENTS

- 0403- Surface Mounting Devices
- SE4W Single Gang Box- PS6L
- SE4W/2 Double Gang Box- PS6L/QC10

AUDIO SPECIFICATIONS

Power Rating	
PS6L	60W-RMS / 25, 70.7 or 100V
PS6L/QC10	20W-RMS / 25, 70.7 or 100V
Switching	
PS6L	Full stop at Pos. 1 and 6, detented
QC10	Continuous, detented
Attenuation	
PS6L/QC10	Steps 1-2, -6 dB
QC10 only	Steps 3-10, -3 dB
	Pos. 10, -36 dB total
Insertion Loss	< 0.5 dB

MECHANICAL SPECIFICATIONS

Mounting	
PS6L	Single Gang electrical box, 2-1/8" deep
PS6L/QC10	Dual Gang electrical box, 2-1/8" deep
Audio Connection	
Input, both devices-	5" pigtail leads
Output, both devices-	7" pigtail leads

Recommended construction sequences, installation instructions and A&E Specifications are available in various formats on the Quam Architects' and Engineers' Resources CD or on the web at: www.quamspeakers.com

Quam-Nichols Company

234 East Marquette Road, Chicago, IL 60637
Phone: (800) NEED NOW Fax: (888) NEED NOW
(800) 633 - 3669 (888) 633 - 3669
E-Mail: neednow@qnc.com www.quamspeakers.com

05 ATTENUATORS / TRANSFORMERS