

INTRODUCTION

Thank you for your purchase of the SL33 Stereo Program Limiter. This device provides smooth dynamics processing for mainly consumer-level equipment. Since there is no audio level standard for consumer audio equipment, the SL33 keeps the levels maintained for a more comfortable listening environment.

WARRANTY

For complete information on the Rolls 1 Year Warranty, and to register this product, see our website at www.rolls.com.

DESCRIPTION

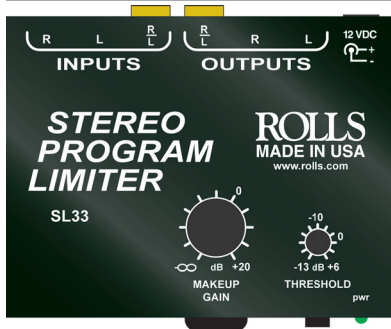

FRONT PANEL

Makeup Gain: This control varies the amount of post-compressor circuit gain. Essentially, this acts as an output level control.
Threshold: This control sets the level at which compression begins.

REAR PANEL

INPUTS: R, L and R/L; 1/4" Tip-Ring-Sleeve balanced and RCA unbalanced input jacks.
OUTPUTS: R, L and R/L; 1/4" Tip-Ring-Sleeve balanced and RCA unbalanced output jacks.
12 VDC: Connects to the included Rolls model PS27 12 VDC power supply.

SCHEMATIC

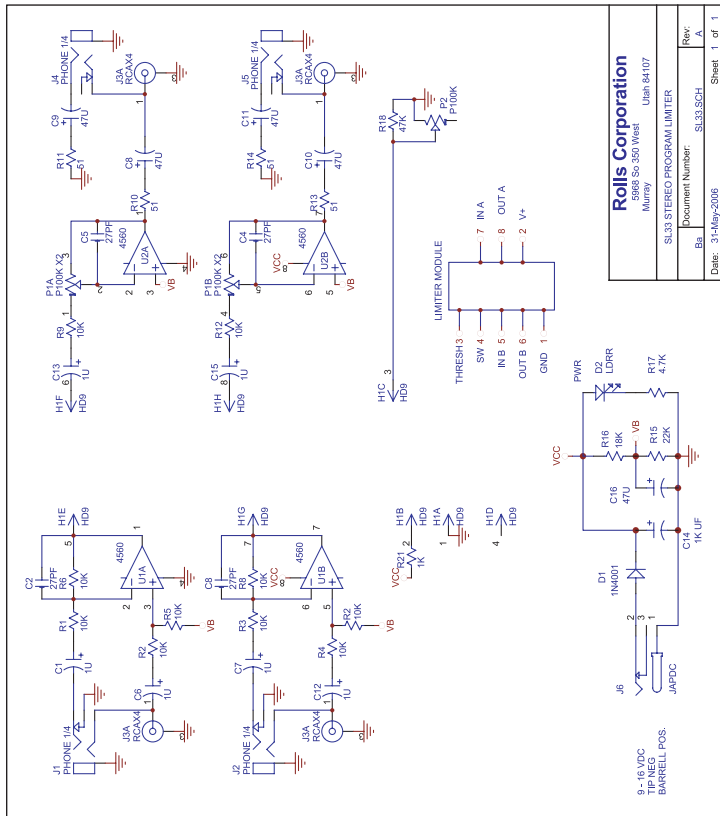

... anywhere you need smooth compression of consumer program material.

ROLLS

- Restaurant
- Night Club
- School/Church

SL33 Stereo Program Limiter

SL33 Stereo Program Limiter

ROLLS

SL33 Stereo Program Limiter

The SL33 acts as an audio program material leveler for mainly consumer audio. It helps control the level over loud, obnoxious commercials for example.

- Stereo Compressor/Limiter
- 1/4" Balanced / RCA unbalanced Inputs and Outputs
- Automatic program limiting
- Output Level control
- Threshold control

SPECIFICATIONS

Inputs: 1/4" TRS balanced, RCA unbalanced
 Outputs: 1/4" TRS balanced, RCA unbalanced
 Compression Ratio: Program dependent
 Threshold: Variable; -13 to +6 dB
 Input Impedance: 10K Ohms bal/unbal
 Output Impedance: 50 Ohms bal/unbal
 Max Output Level: + 13 dBV
 Power: 12 VDC, 50 mA
 Dimensions: 4" x 3.35" x 1.5" (W x H x D)
 Weight: 1 lb.



Rolls Corporation
 Salt Lake City, UT
 6/06

ROLLS

SL33 Stereo Limiter



6 75889 00033 7