

# P4M

## Four-Channel Personal Monitor Mixer

**WARNING!**

**USING THIS SYSTEM AT EXCESSIVE VOLUMES CAN CAUSE PERMANENT HEARING DAMAGE.  
USE AS LOW A VOLUME AS POSSIBLE.**

In order to use this system safely, avoid prolonged listening at excessive sound pressure levels. Please use the following guidelines established by the Occupational Safety Health Administration (OSHA) on maximum time exposure to sound pressure levels before hearing damage occurs.

90 dB SPL at 8 hours

95 dB SPL at 4 hours

100 dB SPL at 2 hours

105 dB SPL at 1 hour

110 dB SPL at 1/2 hour

115 dB SPL at 15 minutes

**120 dB SPL — avoid or damage may occur**

It is difficult to measure the exact Sound Pressure Levels (SPL) present at the eardrum in live applications. In addition to the volume setting on the PSM, the SPL in the ear is affected by ambient sound from floor wedges or other devices. The isolation provided by the fit of quality earphones is also an important factor in determining the SPL in the ear.

Here are some general tips to follow in the use of this product to protect your ears from damage:

1. Turn up the volume control only far enough to hear properly.
2. Ringing in the ears may indicate that the gain levels are too high. Try lowering the gain levels.
3. Have your ears checked by an audiologist on a regular basis. If you experience wax buildup in your ears, stop using the system until an audiologist has examined your ears.
4. Wipe the earphones with an antiseptic before and after use to avoid infections. Stop using the earphones if they are causing great discomfort or infection.



This symbol indicates that there are important operating and maintenance instructions in the literature accompanying this unit.

# INTRODUCTION

Thank you for buying the Shure P4M Personal Monitor Mixer. The P4M is a half-rack, four channel monitor mixer designed for live performance use. Use it with a Shure Personal Stereo Monitoring (PSM<sup>®</sup>) system, or in any other application appropriate for a versatile, compact mixer. When used with a PSM system, the P4M provides several enhancements to in-ear monitoring:

- **Consistency** – same mix every night,
- **Independence** – monitor mixes created and controlled by the performer,
- **Flexibility** – provides monitor mixes regardless of a venue’s sound system capabilities.

For information on any Shure PSM System, please refer to the appropriate user’s guide, available on the world wide web at [www.shure.com](http://www.shure.com).

# P4M MIXER FEATURES

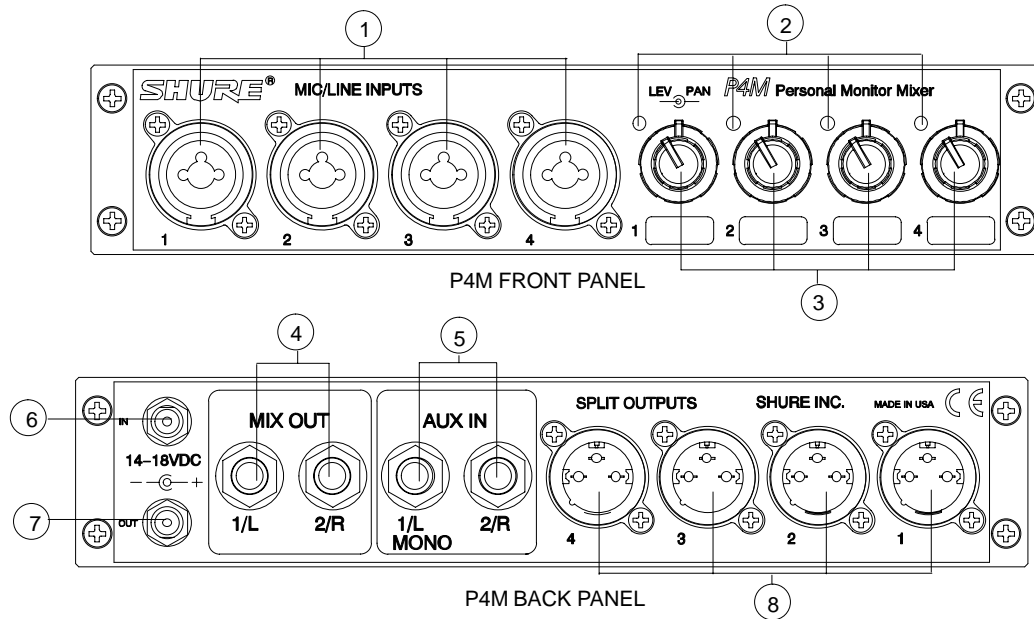

- Input Jacks:** Accommodate both XLR and 1/4" connectors at mic or line levels. They are electronically balanced.
- Signal/Clip LEDs:** Color indicates the signal status of the corresponding Mic/Line Input:
 

LED Color	Signal Status
Green	Signal present
Yellow	Nominal Level
Red	Signal clipping
- Concentric Level/Pan Knobs:** The inner knob controls the input level; the outer ring pans the input signal between the 1/L and 2/R mix outputs.
- Mix Output Jacks:** 1/4" TRS jacks provide the line level mix created with the Level/Pan knobs.
- AUX Inputs:** Signals from the two 1/4" TRS input jacks are combined with the mix created by the Level/Pan knobs. Front panel settings do not affect these jacks.
- DC IN Locking Connector:** Plug the PS40 AC Adaptor into the top connector.
- DC OUT Locking Connector:** Powers a P4T Transmitter or another P4M Mixer. A DC Jumper Cable is provided with the P4M. **NOTE:** A PS40 can only power two Shure devices.
- Split Outputs:** Each male XLR output provides a duplicate of its corresponding mic/line input. Front panel settings have no effect on Split Outputs.

## Set Up

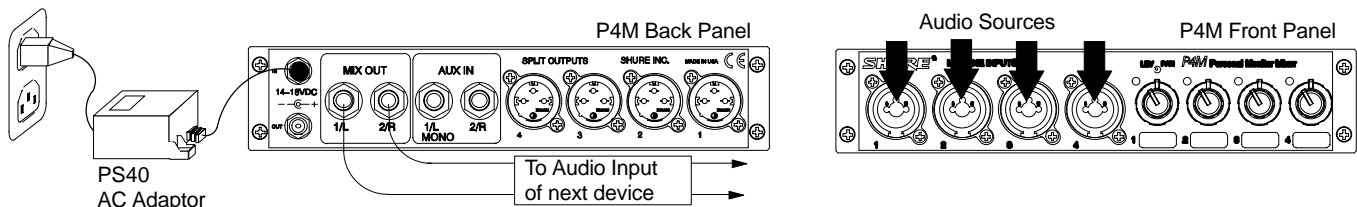

1. Plug the PS40 AC Adaptor into the mixer’s DC IN locking connector. Plug the other end into a wall socket.
2. Connect the MIX OUTPUT jacks to the the audio input of the next device.
3. Connect up to four audio sources (microphones, instruments, mixers) into the input jacks on the front panel.

# USING THE P4M PERSONAL MONITOR MIXER

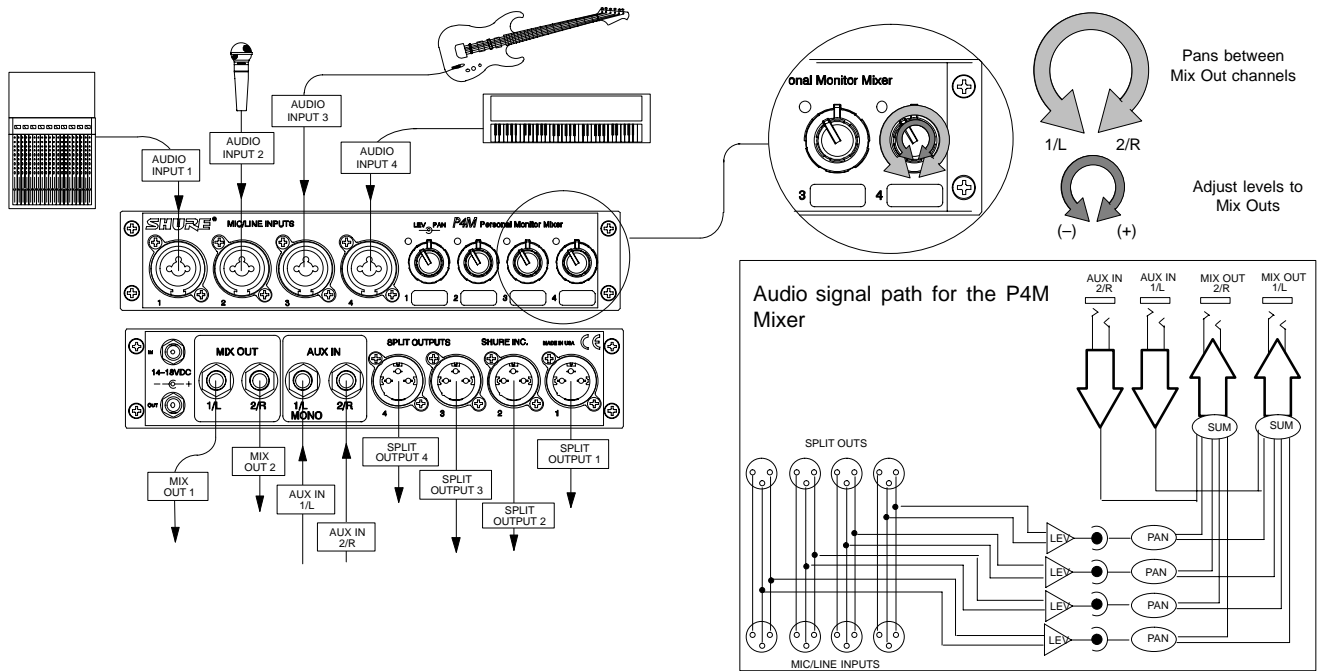

Once the basic set up is complete, use the P4M Personal Monitor Mixer to create a custom mix:

- Mix the signal from each audio input using the corresponding CONCENTRIC LEVEL/PAN knobs:  
 OUTER RING: Use this to pan the signal to the left or right channel of the stereo mix.  
 INNER KNOB: Use this to control the level of the audio input.
- Observe the signal/clip LEDs next to each CONCENTRIC LEVEL/PAN knob.  
**NOTE:** Decrease the level of an input if the corresponding signal/clip LED is consistently red. If the level is decreased all the way and the LED remains red, the level of the input from the previous device in the audio chain is too high and should be decreased.
- Up to two additional line-level audio sources (such as other mixers, a click track or a digital sequencer) may be added via the AUX IN inputs. These signals go directly to the MIX OUT outputs and are not affected by the CONCENTRIC LEVEL/PAN knobs.
- To pass an unaltered signal through the P4M, use the corresponding SPLIT OUTPUT.  
**NOTE:** Although the P4M does not provide phantom power for condenser microphones, the SPLIT OUTPUTS can pass phantom power from a phantom power supply to a microphone connected to the corresponding input jack.

## APPLICATIONS

The flexible design of the P4M Mixer allows it to be used in many different applications. The following examples introduce principles which will allow you to develop personalized setups for your specific application.

### APPLICATION ONE: One P4M Mixer to One Audio Device

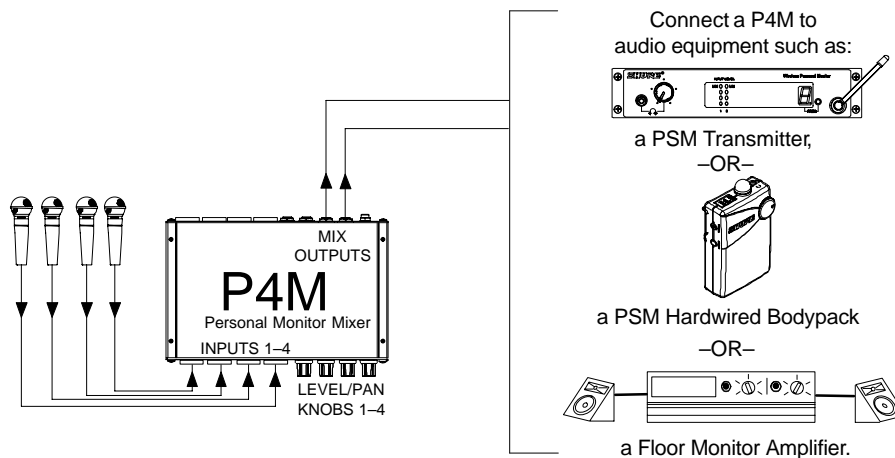

This is the basic configuration of the P4M Mixer, and is recommended for small ensembles in rehearsal or performance situations:

- Connect up to four microphones, instruments or audio devices to inputs 1-4 on the front panel of the P4M.
- Mix the four signals using the LEVEL/PAN knobs adjacent to the inputs.
- Connect the MIX 1/L OUTPUT and MIX 2/R OUTPUT on the back panel of the P4M to an appropriate piece of audio equipment.

## APPLICATION TWO: Multiple P4M Personal Monitor Mixers to One Audio Device

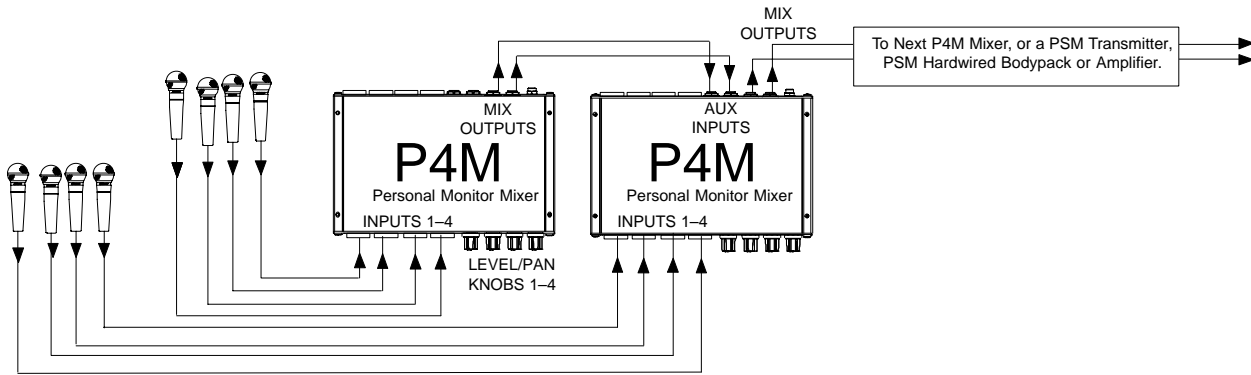

This application, using the P4M's AUX Inputs, allows more than four inputs to be mixed, and is recommended for larger ensembles in live or rehearsal situations:

1. Connect up to four audio sources into the front panel inputs of a P4M.
2. Mix these signals using the corresponding LEVEL/PAN knobs on the P4M.
3. Connect the MIX OUT outputs of the first P4M to the AUX IN inputs of a second P4M.
4. Connect up to four more audio sources into the front panel inputs of the second P4M Mixer.
5. Mix these signals using the corresponding LEVEL/PAN knobs on the second P4M.
6. Connect the MIX OUT outputs of the second P4M to an appropriate piece of audio equipment.

**NOTE:** If more than eight inputs are required, connect additional P4M Mixers after the second P4M, using the connection described in step 3 above.

## APPLICATION THREE: Multiple P4M Personal Monitor Mixers to Multiple Audio Devices

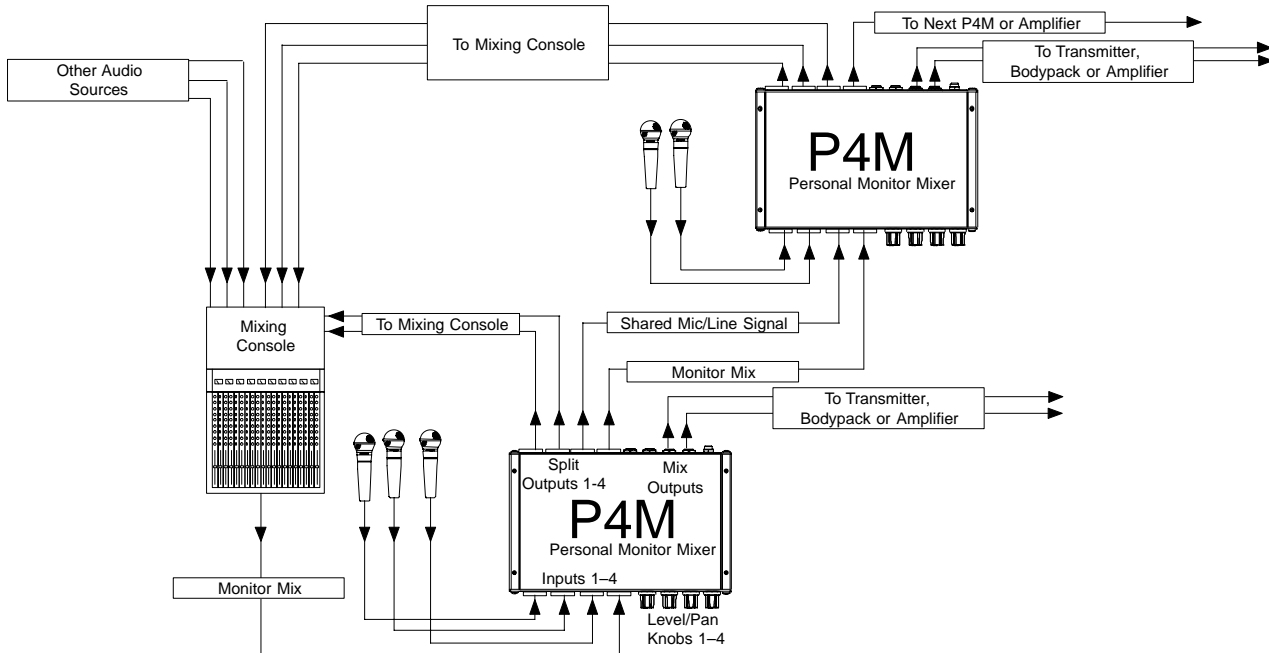

This configuration, using the P4M's SPLIT OUTPUTS, allows each player to hear a custom mix created at their own P4M Personal Monitor Mixer, and is recommended for live, studio or rehearsal situations:

1. Connect a monitor mix (from a mixing console) and up to three microphones or instruments to the four inputs on the P4M Mixer front panel.
2. Connect the P4M SPLIT OUTPUTS containing the monitor mix to an input on a second P4M.
3. Connect the other SPLIT OUTPUTS from the first P4M to either the second P4M or to the mixing console.
4. On the second P4M, connect the SPLIT OUTPUT containing the monitor mix to a third P4M or to a floor monitor amplifier. The other SPLIT OUTPUTS may be connected to a third P4M or to the mixing console.
5. Connect MIX OUT 1/L and MIX OUT 2/R on the back panel of each P4M to an audio device such as a P4T Transmitter, PSM Hardwired Bodypack or a floor monitor amplifier.
6. On each P4M, mix the four signals using the LEVEL/PAN knobs on the front panel.

## APPLICATION FOUR: One P4M Personal Monitor Mixer to Two PSM Transmitters/Receivers

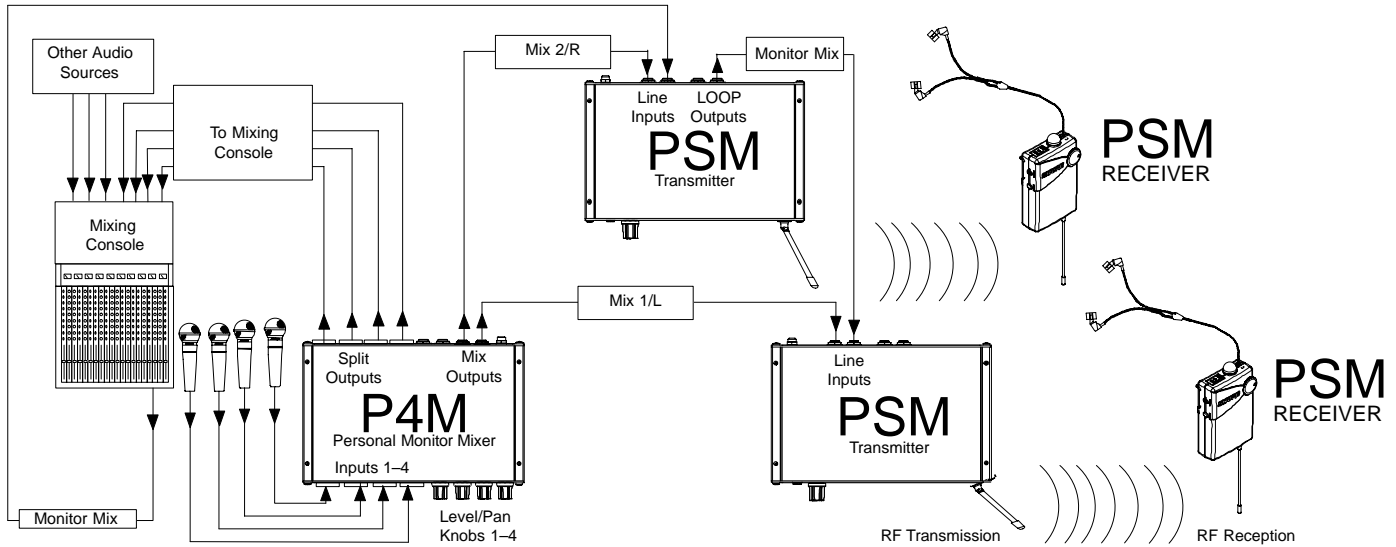

This configuration, using the P4M's SPLIT OUTPUT and a PSM transmitter's LOOP OUTPUT, allows one P4M to provide custom mixes to two PSM transmitters, and is recommended for small ensembles in live performance:

1. Connect up to four microphones or instruments into the P4M inputs. Connect the SPLIT OUTPUTS to a mixing console.
2. Connect a monitor mix from a mixing console to the first PSM transmitter (P4T transmitter shown).
3. On the first PSM transmitter, connect the LOOP output containing the monitor mix to an input on the second PSM transmitter (See appropriate PSM System User's Guide for details).
4. Connect a MIX OUT output to each transmitters' remaining input. Use the front-panel PAN knobs to balance input signals between the two transmitters.
5. Place the PSM receivers in MixMode (see appropriate PSM System User's Guide). Use the balance wheel on the PSM receiver to blend the monitor mix with the custom mix created by the P4M.

## RACK MOUNTING THE P4M PERSONAL MONITOR MIXER

The P4M features a 1/2-rack chassis specially designed for sturdiness. This eliminates the sagging and bending found in most 1/2-rack designs — the brackets and straddle bars ensure that the units will be installed securely.

**WARNING:** Do not torque the screws too tightly, or the chassis may be damaged.

### Single Unit

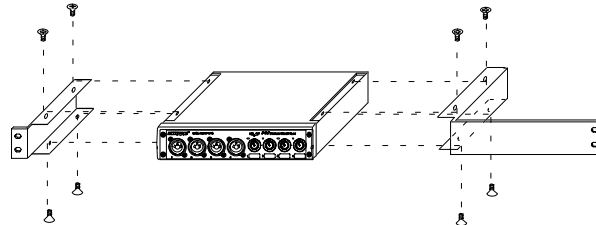

### Dual-Mounted Units

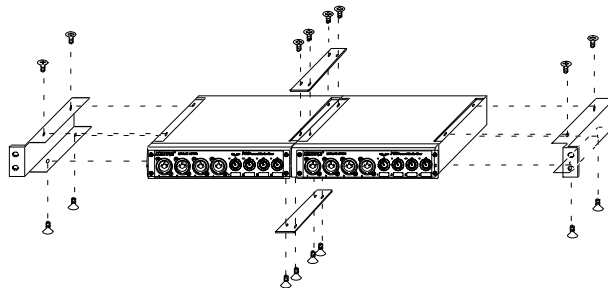

**NOTE:** Be sure to use both straddle bars when installing dual units.

### Mounting in an Equipment Rack



## Specifications

*Measurement Conditions (unless otherwise specified): full gain; 1 kHz, one channel activated; source impedances: Mic 150 Ω, Aux Level 150 Ω; terminations: Line 600 Ω.*

**Frequency Response** (Ref 1 kHz, controls centered)  
20 Hz to 20 kHz ± 2 dB

### INPUT Specifications

	Input	
	1–4 (front panel)	Aux In
Gain (Maximum)	43 dB	0 dB
Impedance (at 1kHz)	5800 Ω	18 kΩ (each) 9100 Ω (1/L mono)
Input Clipping Level	+12dBV	+12 dBV
Crosstalk	-100 dB	-90 dB
Common Mode Rejection	> 75 dB	> 70 dB

### OUTPUT Specifications

	Output	
	Split 1–4	Mix Out
Impedance	N/A	500 Ω (unbalanced) 1kΩ (balanced)
Output Clipping Level	N/A	+5 dBV (10 kΩ balanced load, -30 dBV input ch. 1–4.)
Noise (100 Hz to 22 kHz)	-110 dBV	-100 dBV (all controls CCW) -62 dBV (all controls CW)
Distortion (THD) at 1kHz)	.0005%	< .05% (0 dBV output)
Crosstalk	-100 dB	-70 dB

#### LEDs: Resultant Mix Out Level

Green: -30 dBV  
Yellow: -10 dBV  
Red: 0 dBV

#### Current

120 mA max.

#### Power Requirements

Operating voltage 14–18 Vdc

Supplied with one of the following external power supplies:

- Model PS40: 120 Vac, 60 Hz input, UL and cUL approvals.
- Model PS40E, Model PS40UK: 230 Vac, 50/60 Hz input, TUV approval with European CE marking, conforms to European Low Voltage Directive 72/23/EEC.

NOTE: Courtesy DC connector is protected from short by a self-resetting "Polyfuse". Maximum recommended load is 250mA. (2 P4Ms or 1 P4T.)

#### Phantom Power

The P4M does not produce phantom power, but phantom power is allowed to pass through Split Outputs 1–4 to inputs 1–4 respectively.

#### Audio Polarity

All outputs in polarity with all inputs.

XLR Pin 2 is "hot" with respect to Pin 3; Pin 1 is ground.

1/4" TRS tip is "hot" with respect to ring; sleeve is ground.

#### Temperature Range

Operating ..... -7° to 49° C (20° to 120° F)

Storage ..... -29° to 74° C (-20° to 165° F)

#### Overall Dimensions

44 mm H x 218 mm W x 162 mm D

(1.72 x 8.60 x 6.37 inches)

#### Net Weight

1.20 Kg (2 lbs, 10 oz)

### Certification

Eligible to bear CE marking. Conforms to European Union EMC directive 89/336/EEC. Meets applicable tests and performance criteria in European Standard EN 55103 (1996) parts 1 and 2, for residential (E1) and light industrial (E2) environments.

### Furnished Accessories

Single Mount Rack Bracket .....	53A8450
Dual Mount Rack Bracket .....	53A8442
Straddle Bars .....	53A8443
AC Adaptor .....	PS40 (120V), PS40E (230V), PS40UK (230V)
DC Jumper Cable .....	95A8420

**SHURE®**

*SHURE Incorporated Web Address: <http://www.shure.com>  
222 Hartrey Avenue, Evanston, IL 60202-3696, U.S.A.  
Phone: 847-866-2200 Fax: 847-866-2279  
In Europe, Phone: 49-7131-72140 Fax: 49-7131-721414  
In Asia, Phone: 852-2893-4290 Fax: 852-2893-4055  
Elsewhere, Phone: 847-866-2200 Fax: 847-866-2585*