



NEW MEMBERS OF THE SOLUTION-D FAMILY

True Diamonds





NEUMANN.BERLIN

THE MICROPHONE COMPANY

Solution-D

The Family

Combinations

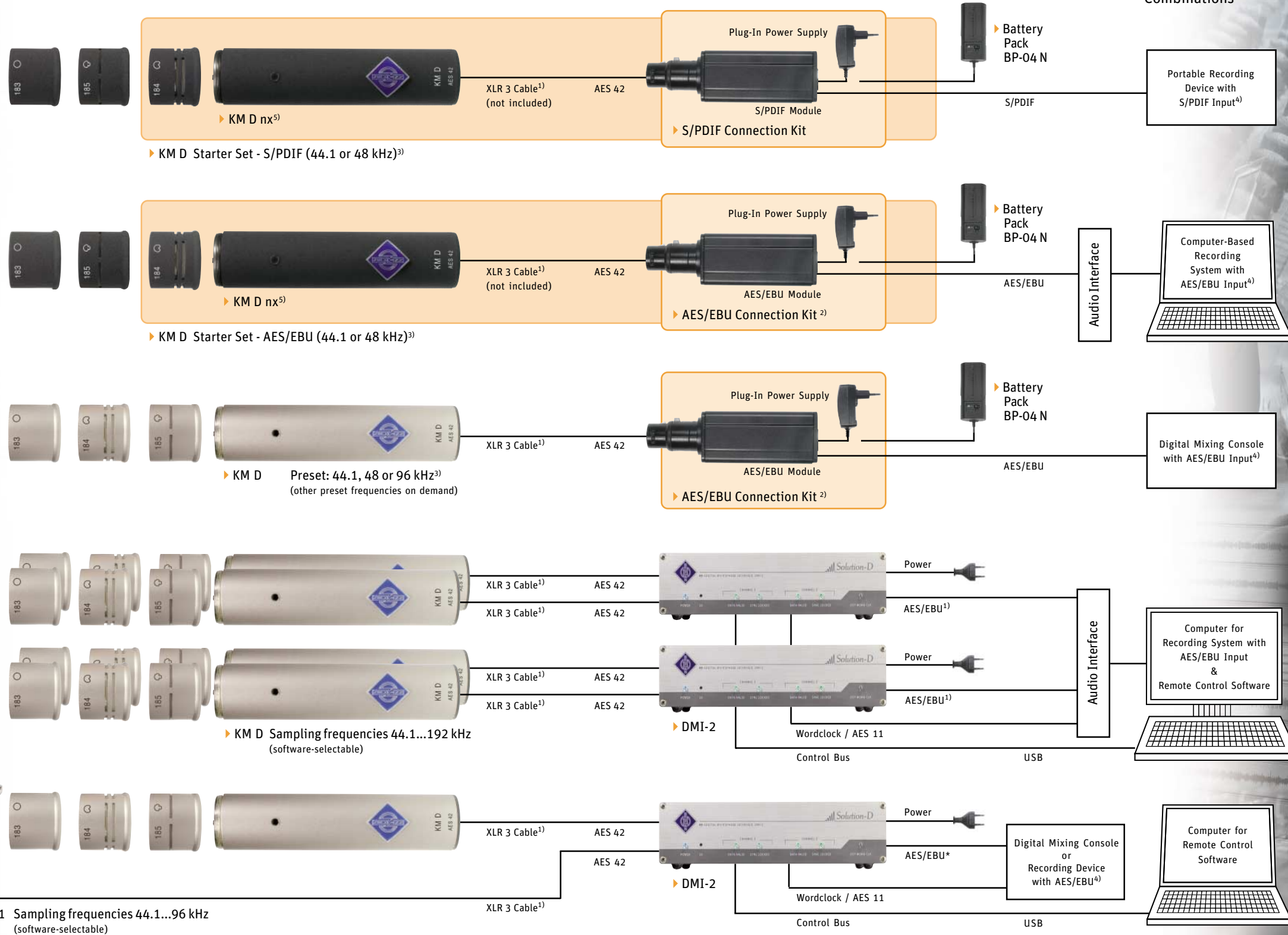

¹⁾ special cable recommended for digital use

²⁾ not necessary when using DMI-2

³⁾ with the DMI-2 the frequency can be set to 44.1, 48, 88.2, 96, 176.4 or 192 kHz

⁴⁾ these are only examples

⁵⁾ nx = Nextel black

TRUE NEUMANN SOUND:
The legendary Neumann sound in the digital realm. Pure Neumann capsule sound.



TRUE TO THE ORIGINAL:
The satisfaction of recording the uncolored original, with no "bottlenecks" between the capsule and the recording system.



TRUE CONVERSION:
The guarantee of having one of the best A/D converters available.



TRUE HANDLING SAFETY:
Anti-clipping processing ensures handling safety, and reduces stress.





The Principle

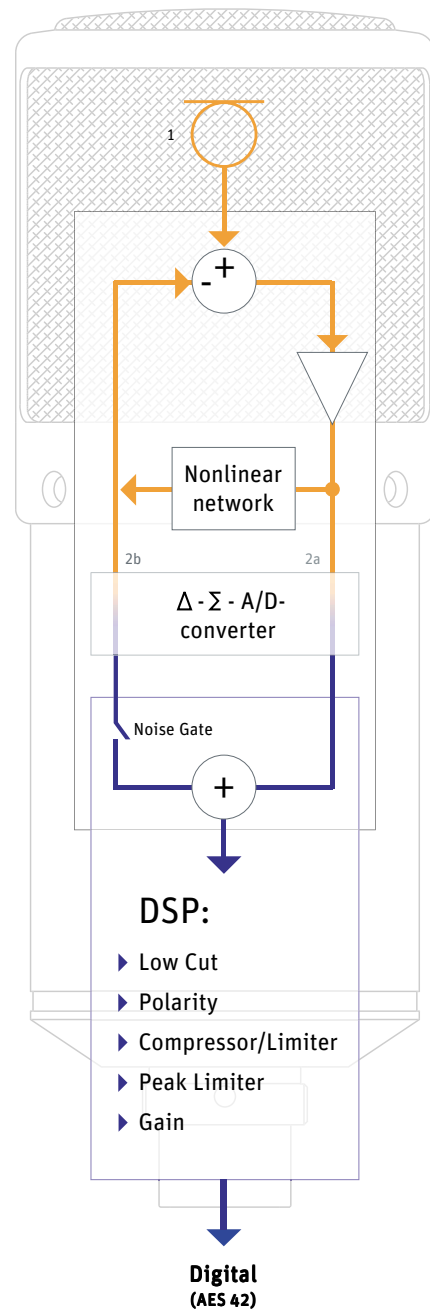

Analog capsule

Ideal matching of Neumann A/D-converter with microphone capsule

Neumann A/D converter:

Patented process

Dynamic range ≥ 140 dB

The capsule signal is transferred to the digital domain without any loss of quality.

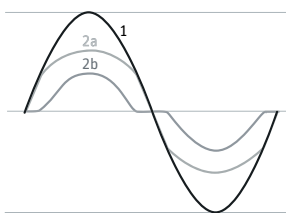

Entire range of functionality remote controlled

Synchronization with studio word clock

Clipping protection



Analog

A/D conversion

DSP

Digital (AES 42)

Recording with no "bottlenecks"

Toolbox

Components & Sets



KM D Starter Set S/PDIF (Preset 44.1 kHz)

KM D Starter Set S/PDIF (Preset 48 kHz)

Contains: 1 KM 184 D nx + Connection Kit S/PDIF + windscreen + clamp



KM D Starter Set AES/EBU (Preset 44.1 kHz)

KM D Starter Set AES/EBU (Preset 48 kHz)

Contains: 1 KM 184 D nx + Connection Kit AES/EBU + windscreen + clamp



Connection Kit S/PDIF
Contains: 1 S/PDIF Module + Plug-In Power Supply



Connection Kit AES/EBU
Contains: 1 AES/EBU Module + Plug-In Power Supply



BP-04 N Battery Pack (batteries not included)



TRUE TIME SAVINGS:
Reduced time requirements and personnel costs, particularly due to faster post production processing.



TRUE ECONOMY:
Lower investment costs, since separate A/D converters and preamps are no longer needed. This also means space and weight savings (e.g. in the OB van).

APPLICATIONS KM 183 D

- For close miking of instruments when there is no need to attenuate extraneous noise, and in a balanced acoustic environment to record acoustic guitar, wind instruments, strings, percussion and drums

- Ideal as AB stereo pair because of the flat frequency response in the diffuse sound field
- Main mic, especially for capturing room acoustics
- For stereo recordings with a baffle plate
- Spot mic for piano, wind instruments, organ and choir





Toolbox

Components & Sets

Large Diaphragm Microphone



D-01 microphone in wooden box



D-01 Mono Set: D-01, elastic suspension, DMI-2, RCS software, interface converter and all cables, in aluminum case)



D-01 Stereo Set: 2 x D-01, elastic suspensions, DMI-2, RCS software, interface converter and all cables, in aluminum case)

DMI-2



DMI-2 (incl. RCS software and cables)

Miniature Microphones



KK 183, KK 184, KK 185



KK 183 nx¹⁾, KK 184 nx¹⁾, KK 185 nx¹⁾



KM D, Preset: 44.1, 48, or 96 kHz²⁾



KM D nx, Preset: 44.1, 48 or 96 kHz²⁾



KM 183 D, KM 184 D, KM 185 D



KM 183 D nx¹⁾, KM 184 D nx¹⁾, KM 185 D nx¹⁾

KM 183/184/185 D (nx) are delivered with wind-screen and clamp, also available as stereo sets.

¹⁾ nx = Nextel black

²⁾ With the DMI-2 the frequency can be set to 44.1, 48, 88.2, 96, 176.4 or 192 kHz

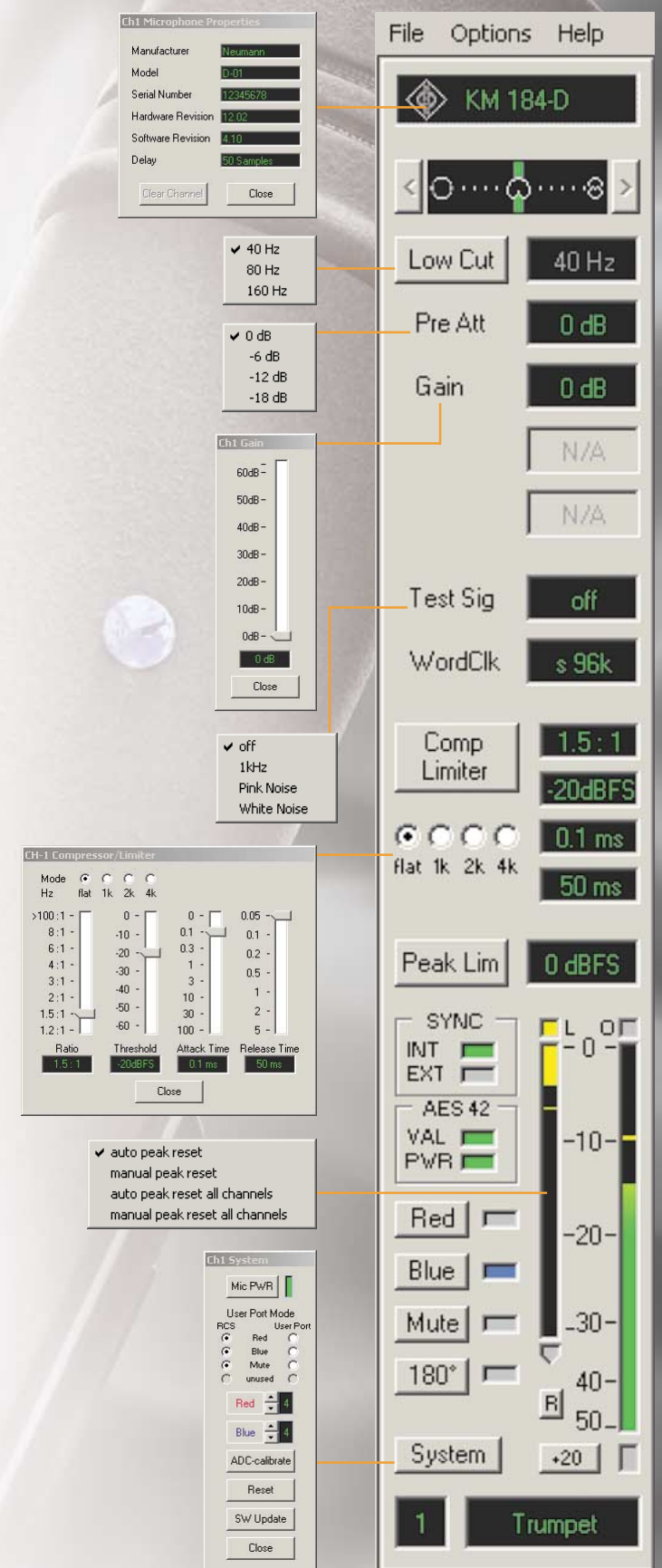

APPLICATIONS KM 184 D

- For universal use, especially for recording situations when it is necessary to attenuate off-axis sound (mainly from the rear) from other nearby instruments.
- As XY and ORTF stereo pair

- Broadcasting mic for announcers
- Spot mic and overhead
- Close miking of strings, wind instruments, percussion, piano, Leslie speakers and guitar amps

APPLICATIONS KM 185 D

- Especially for recording situations when it is necessary to attenuate off-axis (lateral and rear) sound from other nearby instruments.
- As XY stereo pair
- Overhead, toms

- In situations that are susceptible to acoustic feedback
- To attenuate unwanted sound of nearby instruments
- Recording of speech, as in TV, movie and video productions, PA systems
- Produces especially warm and bass supporting sound for artists who perform in the proximity effect range





▶ General Specifications of the Solution-D microphones

Interface: AES 42

Remote controlled¹⁾ functions:

- Polar pattern⁵⁾
- Low-cut: flat, 40, 80, 160 Hz
- Pre-attenuation: 0, -6, -12, -18 dB
- Gain: 0...63 dB in 1 dB steps, clickless
- Testsignal: 1 kHz, pink noise, white noise
- Parametric compressor/limiter (incl. de-esser function)
- Independent peak limiter avoiding any clipping
- Switch functions: soft muting, phase reverse, signal lights
- Signal lights: red⁵⁾ and blue LEDs (switchable via control software or User Port)

A/D conversion: Neumann process (patented), 28-bit internal word length

Digital signal processing: Fixed-point, variable internal word length 28 bits to 60 bits

Synchronization:

AES 42-Mode 2, Mode 1 (asynchronous),
Asynchronous operation (free-running),
basic frequency accuracy: ± 25 ppm
Synchronous operation, pull-in range: Min. ± 100 ppm
Power supply (phantom power complying with AES 42)
Supply voltage range: +7 V to +10,5 V

Output: XLR3M, 24 bits as per AES/EBU (AES 3)

▶ KM 183 / 184 / 185 D Specifications

Acoustic transducer: KK 183/184/185 (known from Series 180)
Directional characteristic: Omni/cardiod/hypercardioid

Frequency response: 20 Hz to 20 kHz
Free-field sensitivity^{2) 3)}: -41/-39/-43 dBFS
Equivalent noise level, CCIR⁴⁾: 24/22/24 dB
Equivalent noise level, A-weighted⁴⁾: 13/13/15 dB-A
Signal-to-noise ratio³⁾, CCIR⁴⁾: 70/72/70 dB
Signal-to-noise ratio³⁾, A-weighted⁴⁾: 81/81/79 dB
Maximum SPL at 0 dBFS: 135/133/137 dB SPL

Sampling rates:

Preset: 44.1, 48 or 96 kHz
(with DMI-2 switchable: 44.1/48/88.2/96/176.4/192 kHz)

Preset Gain: 10 dB (variable with DMI-2)

Current consumption: max. 150 mA

Weight: approx. 80/84/88 g, Diameter: 22 mm, Length: 108 mm

▶ D-01 Specifications

Acoustic transducer: K 07 large double-diaphragm capsule, diameter 30 mm with protected internal electrodes
Directional characteristic: 15 remote controllable polar patterns, from omni to cardioid to figure-8

Frequency response: 20 Hz to 20 kHz
Free-field sensitivity^{2) 3)}: -43 dBFS
Equivalent noise level, CCIR⁴⁾: 18 dB
Equivalent noise level, A-weighted⁴⁾: 7 dB-A
Signal-to-noise ratio³⁾, CCIR⁴⁾: 76 dB
Signal-to-noise ratio³⁾, A-weighted⁴⁾: 87 dB
Maximum SPL at 0 dBFS: 137 dB SPL
Dynamic range, A-weighted⁴⁾: 130 dB

Sampling rates: 44.1, 48, 88.2, 96 kHz

Current consumption: max. 230 mA

Weight: approx. 700 g, Diameter: 63.5 mm, Length: 185 mm

▶ DMI-2 (Digital Microphone Interface) Specifications

2 channels, Inputs: XLR3F, AES 42,
Outputs: XLR3M, AES/EBU, 24 bit.

Control bus: RS485 via RJ 45 jack. Second RJ 45 jack for cascading purposes (up to 4 DMI devices today, 16 devices in future). Connection to the computer's USB port via Neumann USB485 interface converter (included).

User Port: 9-pin sub-D, 3 functions per channel

Synchronization: AES 42 - Mode 2 (PLL system using an external Word Clock and remote controlling the VCXO in the microphone, default mode), AES 42 - Mode 1, (asynchronous, needs a sample rate converter (SRC) at the receiver side).

Word clock input: BNC, 75 ohms.

Word clock output: BNC, 75 ohms, automatically set to the internal word clock master when no external word clock received. Selectable internal sampling rates: 44.1, 48, 88.2, 96, 176.4, 192 kHz.

External Word clock: 44.1, 48, 88.2, 96, 176.4, 192 kHz or AES 11 format.

Indicators: Data Valid (AES 42) and Sync Locked (Mode 2) for each channel, Power On and Ext. Word Clock.

Power supply: 90-240 V, 50/60 Hz.

Storage of the last microphone settings and reloading to the microphones after power on automatically without the need of the computer/RCS.

▶ Features of the RCS (Remote Control Software)

Communication via USB port (Win 2000/98SE/ME/XP, MAC OS version 8.6...10 on PowerPC)

Up to 8 channels displayed simultaneously on the screen

Controllable functions: polar pattern, low-cut, pre-attenuation, gain, test signals, limiter/compressor/de-esser, peak limiter, phase reverse, mute, sampling rate, synchronization mode, signal lights,...

Display: peak level meter, gain reduction meter for compressor/limiter/de-esser and peak limiter, microphone properties (manufacturer, model, serial number, hardware and software revision, internal latency time), DMI properties, status signals (overload, limiter active, data valid, sync locked, power on)

Saving/Loading of configurations
Individual channel labelling

Software update of Neumann microphones and DMI device

▶ Battery Pack BP 04 N Specifications

4 AA (rechargeable) batteries (not included)

Weight: approx. 84 g (without batteries)

Diameter: 43 mm, Length: 105 mm

▶ Connection Kit S/PDIF (AES/EBU) Specifications

Connector: input XLR3F, output Cinch (XLR3M)

Weight: approx. 96 g (S/PDIF), approx. 130 g (AES/EBU)

Width: 32 mm, Height: 26 mm, Length: 105 mm

Power supply: 90-240 V, 50/60 Hz

For remote controlling functions you have to use the DMI-2

All data with respect to 0 dB pre-attenuation and 0 dB gain.

1) Remote control with DMI-2 only

2) at 1 kHz

3) re 94 dB SPL

4) according to IEC 60268-1;

CCIR-weighting according to CCIR 468-3, quasi peak;

A-weighting according to IEC 61672-1, RMS

5) D-01 only

