

Community

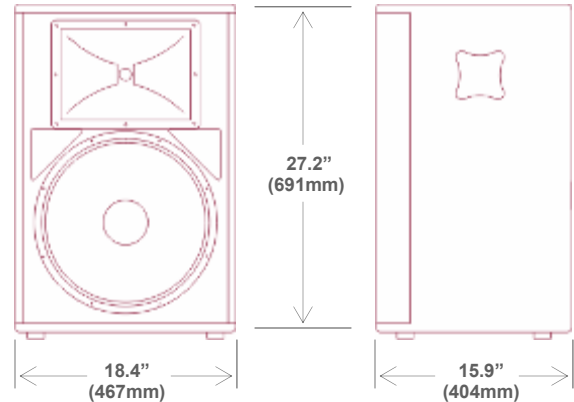

SONUS-1596

TWO-WAY FULL-RANGE LOUDSPEAKER SYSTEM



Description

The SONUS-1596 is a two-way, ruggedly built full-range loudspeaker system, suitable for both portable usage and fixed installations.

Exhibiting exceptionally powerful output capability, with a clear and low-distortion sonic quality, the SONUS-1596 is ideal for applications ranging from acoustic jazz in coffee houses, to large dance clubs and rock and roll venues.

The unit comes equipped with M10 fly points on the top, bottom and rear surfaces, as well as a support stand fitting and rubber feet, permitting a great deal of versatility in use.

Utilizing engineering achievements normally found only in high priced touring systems, the SONUS-1596 provides extended high frequency response, powerful bass reproduction, and precise pattern control.

Featuring carefully designed crossovers that provide flat acoustic power response throughout the critical mid-range region, a high frequency driver treated with Ferrofluid to dampen resonance and increase power handling, plus DYNA-TECH™ internal protection circuitry, the SONUS-1596 satisfies the demanding needs of audio rental companies, professional touring musicians, and pro audio installation contractors alike.

Applications

- **Clubs**
- **Concerts**
- **Mobile DJ**
- **AV Rental**

Features

- **DYNA-TECH™ Dynamic Protection**
- **Switchable Bi-amp / Single-amp Operation**
- **Switchable Music / Speech Voicing**
- **Ferrofluid Treated HF Driver for Improved Heat Transfer**
- **Non-Resonant, Non-Metallic HF Diaphragm for Reduced Distortion**
- **Carbon Ring Cone Technology Provides 30% More Piston Area with Increased Excursion Capability**
- **Dual NL4 and Dual 1/4" Input / Output Connectors**

SYSTEM

- **Format:** Two-way full-range, vented bass - switchable passive or bi-amp x-over
- **Operating Range:** 50 Hz - 20 kHz
- **Frequency Response:** 90 Hz - 16 kHz (±3.5 dB)
- **Dispersion (-6 dB):** 90° H x 60° V
- **Maximum SPL @1m:** 124 dB continuous / 131 dB peak
- **Crossover Frequency:** 1.5 kHz
- **Sensitivity in SPL:** 101 dB (100 Hz - 10 kHz, 1/3 octave) (1W/1m free space) 102 dB (250 Hz - 4 kHz, speech range)
- **Max Power Handling:** 200W RMS (passive mode) 500W Program / 990W Peak
- **Impedance (passive):** Nominal 8Ω / Min. 4Ω at 8.5 kHz

TRANSDUCERS

- **Low Frequency:** 15" (381mm) 200W RMS 500W Program, 8Ω
- **High Frequency:** 1" (25.4mm) 50W RMS 125W Program, 4Ω

MECHANICAL

- **Enclosure:** 11-ply cross-laminated birch
- **Finish:** Black catalyzed polyester paint
- **Rigging Provisions:** 10 - M10 threaded rigging fittings¹ (four on top, four on bottom, two on rear)
- **Grille:** Steel, powder coated black
- **Dimensions:** 27.2" (691mm) x 18.4" (467mm) x 15.9" (404mm) H x W x D
- **Net Weight:** 46.5 lbs / 21.1 kg

¹ Due to ongoing development, specifications are subject to change without notice.

¹ 100 lbs / 45.4kg per point in straight line, 10:1 safety factor

SONUS-1596 TWO-WAY FULL-RANGE LOUDSPEAKER SYSTEM

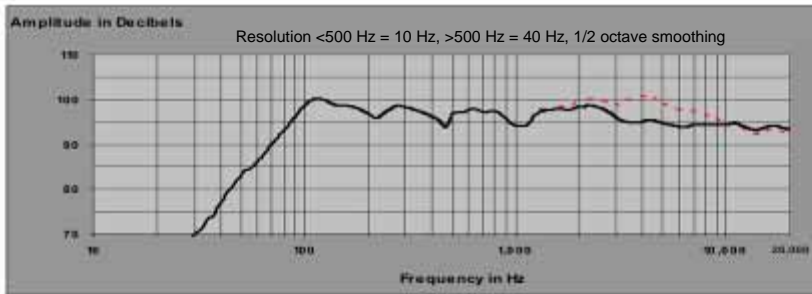

FREQUENCY RESPONSE

Note: Response may be altered by use of *Presence Switch*. The dotted red line depicts the MUSIC position; the solid black line depicts the SPEECH position.

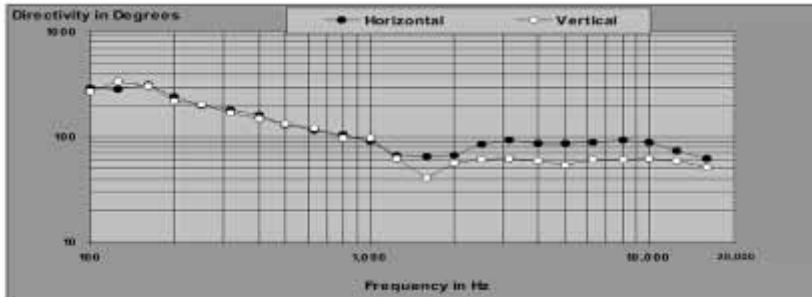

BEAMWIDTH

Note: Indicates Horizontal and Vertical Directivity Index in Degrees vs. Frequency.

Recommended Power: 400 to 625 WRMS¹ at 8Ω

Recommended High-Pass Filter: 50 Hz, 24 dB/octave

¹WRMS = Watts Root Mean Square

Accessories



Padded Transport Covers
Protect your SONUS loudspeakers from scratches and mars.
Model CVR-S15



Eyebolt Kit

Suspend your SONUS loudspeakers safely and easily.
Model M10EYBLTKIT

Vertical Fly Kit

One kit lets you fly two SONUS enclosures in a splayed array; two kits let you fly three enclosures, and so on. **Model VFKIT**



Seat Track Rigging Kit

The quick-release fittings get your SONUS enclosures up in the air and back down again, quickly and safely.
Model STKIT



Support Stand

Elevates a full-range SONUS loudspeaker using the subwoofer as the base.
Model SB5



Community Professional Loudspeakers, 333 East Fifth Street, Chester, PA USA 19013-4511
TEL: 610-876-3400 · FAX: 610-874-0190 · www.communitypro.com