

Installation Guide

BC12-17-2

Dual Off-Set Hang Point Beam Clamp



Figure 1

The BC12-17-2 channel style beam clamp to provide a load rated overhead rigging point from structural I-Beams with flange widths ranging between 12" and 17" and with 1/4" to 1" thick flanges. This beam clamp model provides a fast, easy and safe way to suspend direct loads, bridles and hitches from overhead.

Important: : Rigging overhead system requires professional experience. Improperly installed equipment can result in property damage, personal injury, death and/or liability to the installing contractor. Do not suspend if in doubt about the integrity of the structure.

NOTE:

Do not exceed the working load limit of 980 lbs / 445 Kg..

The BC12-17-2 is not to be used for suspending personnel.

Recommended torque = 40-50 ft/lb

Contents:

Be sure that all of the following items are included in this kit before proceeding:

- 1 pc 12"-17" Beam clamp assembly
- 2 pcs 5/8 Eye nut
- 1 pc Instruction sheet

Installation Procedure:

Step 1:

Determine the thickness of the I-beam's flange to properly select the right spacer plate to use. Remove the 5/8" nyloc nut and flat washer to test fit the locking plate and spacers. Try a different combination of single, double of all three spacer plates (figure 1).

Step 2:

Re-install the 5/8" nyloc nut and flat washer when the appropriate spacer plate is determined. Attach the beam clamp to the structure's I-beam (Figure 1 and 2).

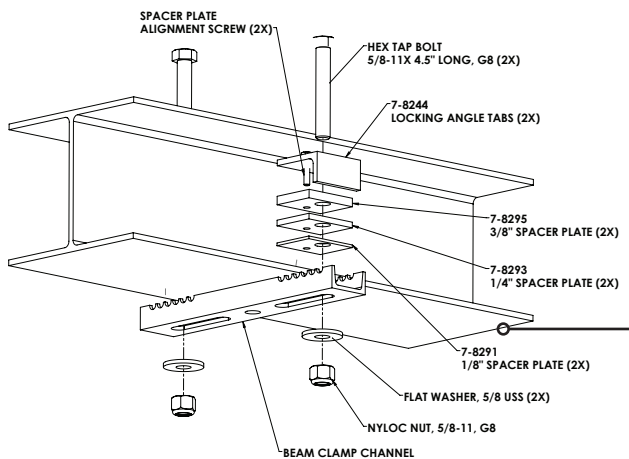

Figure 2

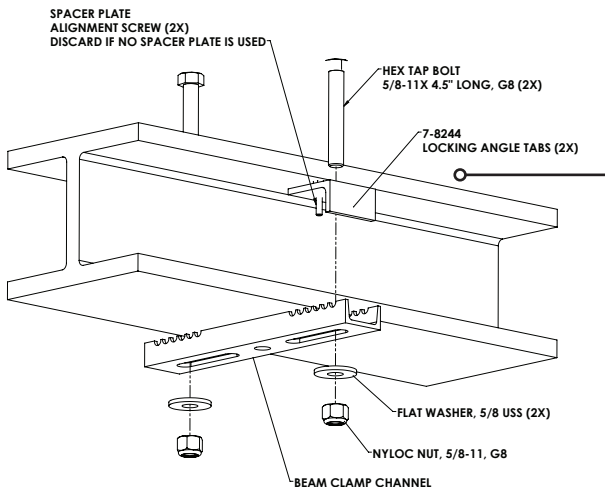
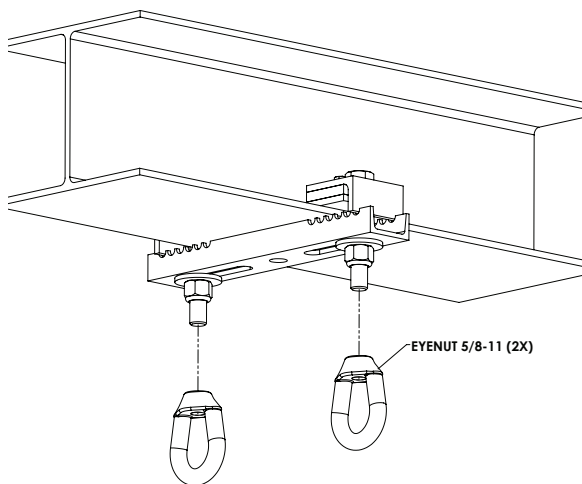

Figure 3



Step 3:

Center the beam clamp on the bottom of the I-beam's flange. Position the locking channel's locking angle tabs with the appropriate spacer plates above the I-beam's flanges. Slide the locking channel tabs against the sides and get the bolt as close as possible to the flanges. Make sure the locking channel tabs are seated on the channel's grooves. Tighten the nuts permanently.

Step 4:

Attach the eye-nuts on the threads of the bolt, tighten permanently (Figure 3).

Recommended torque = 40-50 ft/lb

Step 5: Check System

Check all connections to make sure all bolts and nuts are tightened.

Step 6:

Suspend equipment evenly to the provided eye-nuts on the beam clamp using load rated hardware (Figure 4).

Note to installers:

Due to the wide variety of wall structures, materials and mounting methods, the installing contractor must exercise proper judgment in selecting the mounting area and hardware.

As a guide, the installation, when complete should be capable of supporting 5 to 10 times the actual applied load. Always use a backup safety system such as a safety cable.

To assure a trouble-free installation, read through and follow these instructions carefully before beginning. If you have doubts about the integrity of the structure you are mounting to or you are not sure about the proper hardware to use, consult a structural and/or hardware specialist.