



Marshall Electronics

Professional Audio Division

Phone: 310-333-0606 · 800-800-6608 · Fax: 310-333-0688

www.mxlmics.com · sales@mxlmics.com



— *Heritage Edition* —

GENESIS



Heritage Edition

Tube Microphone



Thank you for choosing the state of the art Heritage Edition Genesis HE microphone from MXL®.

Your new Genesis HE microphone was designed and engineered in the USA by our world class team of electrical and audio engineers, and is built for the most critical sound applications. As the flagship of the MXL® product family, the Genesis HE exhibits a warmth and intimacy previously only found in microphones costing many times more.

The MXL® Genesis HE features individually selected components, chosen for their superior sonic capabilities. One of the key components is the Mullard 12AT7 tube, which is universally accepted as one of the most musical tubes available. Your Genesis HE will provide many years of outstanding service, and will always ensure you get the finest quality recordings attainable.

To assist you in obtaining the best possible results from your MXL® Genesis HE microphone, we have provided some tips, tricks and answers to commonly asked questions.

We encourage you to review these materials.

Genesis HE Specs

Type:	Vacuum Tube Studio Condenser Microphone
Tube Type:	Mullard 12AT7 or equivalent
Diaphragm:	6 micron gold-sputtered
Frequency Response:	20 Hz – 20 kHz
Polar pattern:	Cardioid
Output Impedance:	200 ohms
Pre-Attenuation Switch:	0 dB, -10 dB
High Pass Filter:	6 dB/octave @ 150 Hz
Equivalent noise:	18db (A-weighted IEC 268-4)
S/N Ratio:	78dB (Ref. 1Pa A-weighted)
Max SPL for .5% THD:	130 dB/140 dB (0dB, -10 dB pad)
Power Requirements:	Dedicated power supply
Size:	59mm x 240mm
Weight:	1.55 lbs.
Metal Finish:	Silver Frost with Chrome Grill

Warranty

MXL microphones are guaranteed against defects in material and workmanship for one year (except tube which is 90 days) from date of purchase. Should you encounter any problem with this unit, promptly contact the company you purchased it from for assistance. The original dated sales receipt will be necessary for any warranty claim. Do not send any unit directly to us without prior authorization from our service department!

Warranty coverage is limited to repair or replacement (at our option) of the microphone, and does not cover incidental damages due to use of this unit, nor damage caused by accidental misuse of this product.

Recording a Drum Set

Like the piano, capturing the drums can be quite a challenge, if for no other reason than the fact that you must be very careful to avoid positioning the microphone(s) where they could be hit! Ideally you'll want a minimum of two microphones for this job, though a single microphone can be employed.

Stereo Overhead Pair: Position the two microphones approximately 16 - 20 inches above the performer's head - separated laterally by roughly 2 - 3 feet and placed 5 - 6 feet out in front of the drum kit. Adjust the two microphone's Pan position so that you achieve a good stereo spread, though generally not hard left and right. (see Fig. 5A)

Single Overhead Microphone: Position the microphone approximately 16 - 20 inches above the performer's head - centered in front of the drum set, and placed 5 - 6 feet out in front. The microphone's Pan position should be centered for mono drums. (see Fig. 5B)

For best results, record the drums in as acoustically "dead" a room as you can. If the room is live, the sharp attack transients of the drum kit will only become that much more difficult to capture if the room has hard, reflective surfaces - resulting in a muddy sound without any real definition. Further, you should always record the drums dry and add signal processing after the fact.

Fig. 5A

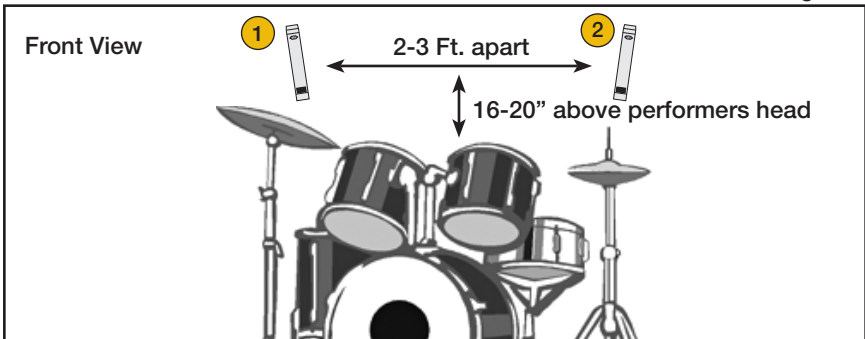
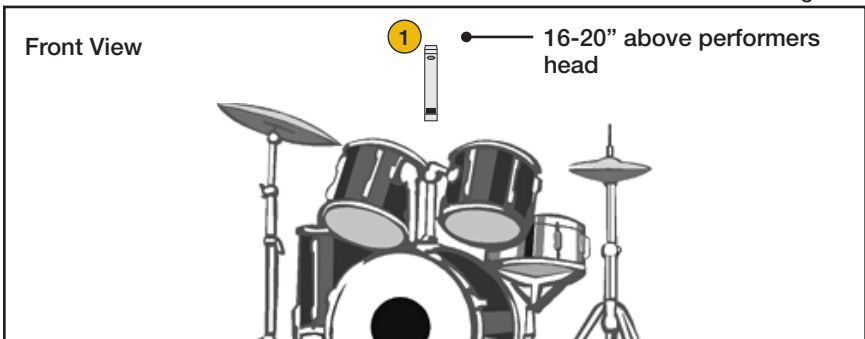

Fig. 5B



Features

Switches

The Genesis HE features switches for both bass roll-off and a -10dB pad. The bass roll-off is set to 6dB per octave at 150 Hz. This can reduce proximity effect if required. Proximity effect is the change of frequency response as the recorded source is brought closer to the microphone. With vocals, this usually manifests itself as an increase in low frequency content as one gets closer to the microphone. The -10dB pad effectively reduces possible overloading of the microphones internal circuitry at high SPLs.

Power Requirements

IMPORTANT -This unit requires the use of the dedicated power supply included in the package. This supply is switchable between 115 volts and 230 volts AC. In North America the microphone ships in the 115 volts AC position and in the 230 Volts AC position for export. However, you always want to

ensure that the power supply voltage is correctly set for your local voltage as permanent damage to the microphone and/or power supply may occur if the incorrect voltage setting is selected. Every MXL® microphone has been thoroughly checked before shipping; so if you hear no sound, check that the power supply is switched on.

Caution

Do not “hot plug” the mic. Always ensure that the power supply is off when plugging and unplugging the included seven-pin cable from the microphone to avoid damaging the microphone and power supply.

Care

Dust and foreign material can degrade the performance of a microphone over time so always store the unit in its case. It is highly recommended to use the specially designed Genesis HE pop filter when recording vocals.

Accessories

Pop Filter

The Genesis HE comes with a custom pop filter which should be used anytime the microphone is being used to record vocals. The pop filter not only eliminates plosives (those “popping Ps”), it helps collect

Continued on page 3



Accessories

Continued from page 2

condensation from one's breath and protects and protects the microphone's capsule from moisture in the process. Condensation on the microphone's capsule will cause the microphone to short circuit - resulting in the microphone cutting in and out of operation. Should this occur, you can leave the microphone uncovered, out in the open for approximately two weeks to thoroughly dry. This will likely rectify the problem. Afterward, you should always use a pop filter.

Shockmount

The Genesis HE comes with a custom shockmount specifically designed to handle its large size. Shockmounts de-couple the microphone from the mic stand and the environment. The shock-mount



The front of the microphone is always indicated by the position of the cardioid pattern symbol. ◌

will minimize floornoise as well as any noise induced by people handling the microphone stand. Shockmounts should be considered “standard equipment” for all recording applications.



Microphone Cables

The microphone cable can have a profound effect on the sound of any microphone. Even the finest microphones will sound poor if the interconnect cable allows noise to enter, or causes distortion and loss of information. We highly recommend exclusively using the Mogami® cables supplied with your Genesis HE Mic.

Fig. 4B

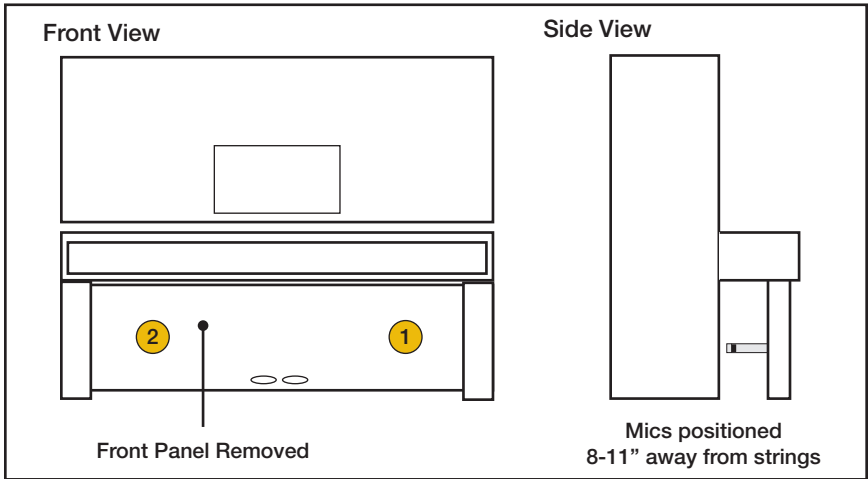

Front Panel Placement: For the upper strings, position the microphone approximately 8 - 11 inches away from the strings, with the Pan position set to left of center. For the lower strings, position the microphone 8 - 11 inches away from the strings, with the Pan position set to right of center. (see Fig. 4B)

Fig. 4C

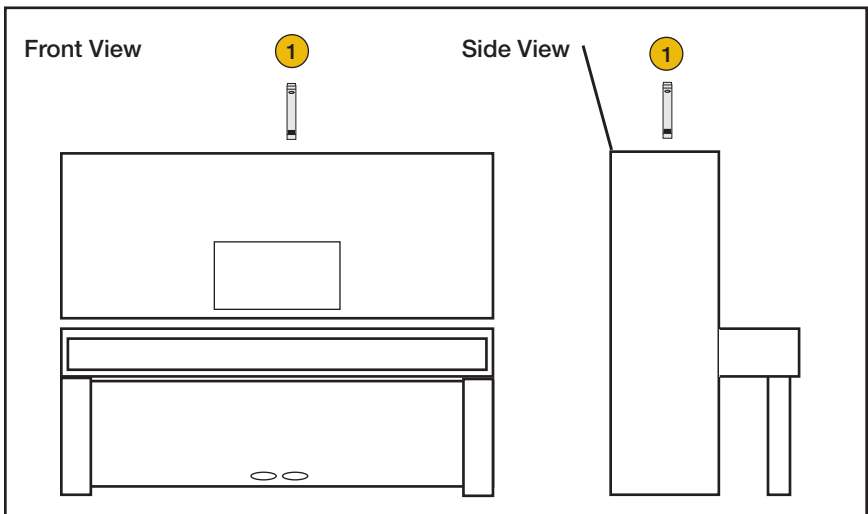

Single Microphone / Open Top: If you are using a single microphone, it is generally recommended that you record from above, as placement of the microphone in the lower center may interfere with the performer's ability to access the pedals and the microphone will likely pick up excessive pedal and other mechanical noise. Position the microphone just over the open top, centered over the instrument. (see Fig. 4C)

Recording the Piano

The piano is one of the most challenging instruments to record, and many problems stem from the quality and maintenance of the instrument itself. You'll obtain the best results by using an instrument that has just been tuned and is in good mechanical condition.

The piano is generally recorded using close miking technique. Ideally, you'll want a minimum of two microphones. Usually, the microphone capturing the higher strings is assigned to the left channel and the microphone capturing the lower strings is assigned to the right channel in the final stereo mix, though the stereo spread generally is not hard left and right. While a single microphone can be used, the lower and upper extremities of the instrument will likely be compromised.

Grand Piano: For the upper strings, position the microphone approximately 8 inches from the piano hammers (to reduce mechanical noise) and 8 - 11 inches above the strings, with the Pan position set to left of center. For the lower strings, position the microphone toward the far end (away from the keyboard) roughly 6 - 12 inches from the end and 8 - 11 inches above the strings, with the Pan position set to right of center. Position the piano's lid at full stick. (see Fig. 4A) If you are using a single microphone, position the microphone approximately 8 inches from the piano hammers (to reduce mechanical noise) and 8 - 11 inches above the strings - centered over the piano's mid point. Pan position should be centered and the piano's lid should be at full stick.

Fig. 4A

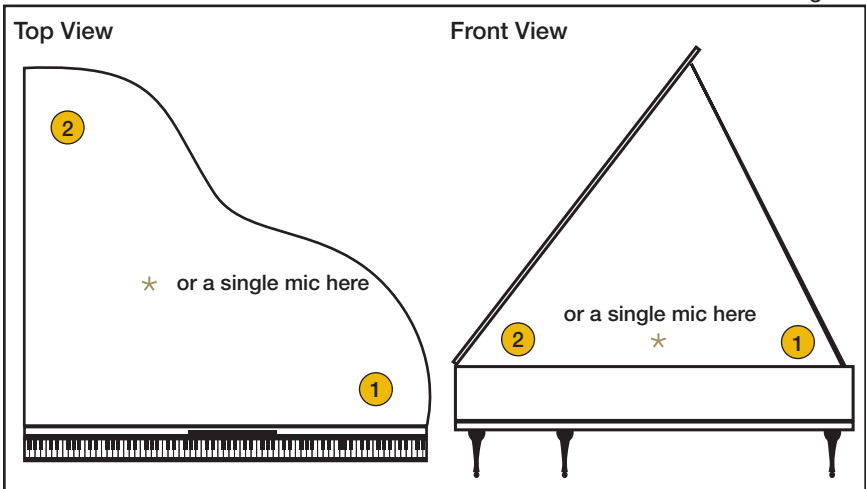

Upright Piano: With an upright piano, the two microphones are generally placed either just over the top of the piano with the top open, or you can remove the piano's front panel beneath the keyboard and place the microphones below.

Recording Vocals and Dialog

Fig. 1



Ideally, you want to record vocals in a relatively “dead” room. If you clap your hands and get an echo effect, you should consider adding some carpet, blankets, drapes, or other sound absorbing materials. On that note, make every effort to avoid getting too close to the room’s walls. These hard, reflective surfaces can easily complicate the recording process. Move your mic setup toward the room’s center.

Generally, you should position the vocalist roughly 6 - 8 inches away from the microphone. Getting too close to the microphone tends to increase bass response and can create problems with plosive sounds - those popping Ps, Bs, Ds, and Ts (more on this in a moment). Getting too far away makes the microphone more subject to picking up room ambience - a sound that creates the effect of the vocalist being in a bowl. While vocalists may need to move about in order to hit those high notes, make every effort to maintain a constant distance from the microphone, as this will provide the greatest tonal balance. (see Fig. 1) For the most part, the microphone’s axis (or center line) should aim toward the nose and mouth to obtain the fullest sound. It’s not a bad idea, however, to experiment angling the microphone slightly away from dead center so as to help minimize plosives. Further, you should always place a “pop” filter between the vocalist and the microphone, with the pop filter positioned 3 - 4 inches in front of the microphone. This will greatly increase your ability to achieve the most natural sounding recordings with minimal interference from plosive sounds. Fixing plosives with audio editing software often creates more of a problem than the plosive itself. Use of a pop filter will also protect your microphone’s sensitive capsule - keeping it free from moisture caused by saliva projecting from the performer’s mouth, and breath condensation. Remember... Good microphone technique, proper positioning, and use of a pop filter can make all the difference between a so-so vocal recording and a great one.

Recording Acoustic Guitar

While it may seem obvious, your best results for capturing the acoustic guitar (or any similar stringed instrument for that matter) begin with a properly tuned instrument and strings that, while not old, aren't so new so as to create tuning issues due to stretching.

There are two optimum points for microphone positioning - either near the bridge or by the twelfth fret. While it may seem natural to place the microphone in front of the instrument's sound hole, doing so usually increases low frequency response to the point of making the instrument sound "boomy."

Twelfth Fret Placement: Placing the microphone roughly 2 - 4 inches from the twelfth fret and aimed directly at the strings will generally produce a warm, full bodied sound with good tonal balance. Using this technique, the sound hole's contribution will be moderated since the microphone is not pointed directly at it.

Bridge Placement: Similarly, you can position the microphone so it is 3 - 6 inches from the guitar's bridge. This will generally produce a somewhat brighter tonal quality. You should also be prepared to experiment positioning the microphone slightly off-axis should you find yourself capturing too much low frequency response from the guitar's sound hole.

The acoustical characteristics of your room will also have a pronounced effect on your results. A "live" room will produce an overall "brighter" guitar sound, while a "damped" room will produce more of a mellow tone. If you have two microphones, you may wish to experiment using one in close proximity to the guitar as previously described, with the second microphone on a stand a few feet away to capture the room's ambience. Blending the two sources can produce excellent results.

Fig. 2

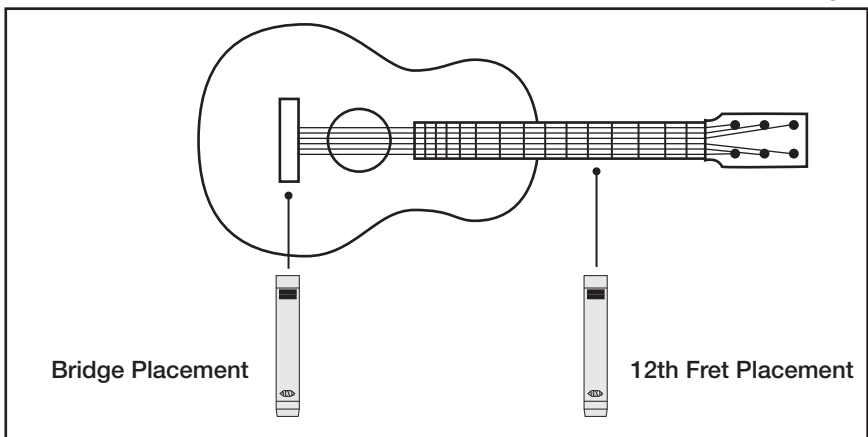

Recording an Amplified (Electric) Guitar

Fig. 3

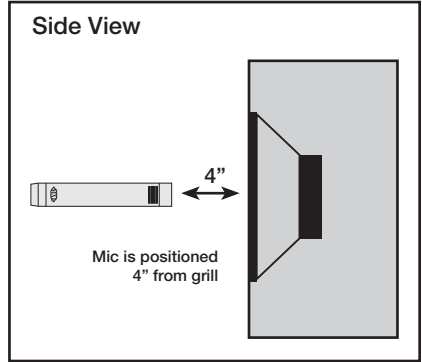
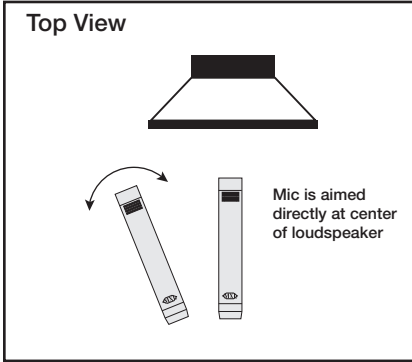

While the electric guitar can certainly be recorded directly, there are times when there is simply no substitute for the sound of a real amplifier. Guitar amps have particular gain stages that facilitate the popular “crunch” guitar sound. While digital modeling and processing systems certainly have their place, they may not have the same level of realism as the sound from an amplifier. A small guitar amp can be just as effective for this application as a stack, because you don’t necessarily need to “crank” the volume. Instead, you want to increase the amp’s initial gain to achieve the desired amount of overdrive.

Typically, a guitar amp is close miked to achieve the highest direct sound. Placing the microphone roughly 4 inches from the grill, aimed directly at the center of the loudspeaker will

produce the most “edge” to your sound. By angling the microphone slightly off axis and towards the wall, you can add more “room sound.” Experimentation is a key factor in achieving the sound you are looking for. (see Fig. 3)

Placement of the amp is another important factor. If the amplifier sits on a carpeted floor, you are more likely to reduce the amount of brightness in the sound. Similarly, elevating the amplifier off the floor may result in a loss of low end. If you’re looking for a big reverberant tone, placing the amp and microphone in the bathroom is another popular technique. The hard tiles and other reflective surfaces can do wonders for a dull sound. In this case, move the microphone back a few feet from the loudspeaker and crank it up!