



## ***User's Manual***

# **event** line array

**EVENT-212A / EVENT-212.120A / EVENT-121A**



Antes de utilizar el equipo, lea la sección "Precauciones de seguridad" de este manual. Conserve este manual para futuras consultas.

Before operating the device, please read the "Safety precautions" section of this manual. Retain this manual for future reference.

## CONTENTS

<b>SAFETY PRECAUTIONS</b> .....	<b>3</b>
<b>WARRANTY</b> .....	<b>4</b>
<b>DECLARATION OF CONFORMITY</b> .....	<b>5</b>
<b>INTRODUCTION</b> .....	<b>6 - 7</b>
<b>CONFIGURATIONS</b> .....	<b>8 - 13</b>
10 x EVENT-212A + 2 x EVENT-212.120A + 6 x EVENT-218A	
12 x EVENT-212A + 4 x EVENT-212.120A + 8 x EVENT-218A	
20 x EVENT-212A + 4 x EVENT-212.120A + 12 x EVENT-218A	
10 x EVENT-212A + 2 x EVENT-212.120A + 4 x EVENT-121A	
12 x EVENT-212A + 4 x EVENT-212.120A + 6 x EVENT-121A	
20 x EVENT-212A + 4 x EVENT-212.120A + 8 x EVENT-121A	
<b>SPECIFICATIONS</b> .....	<b>14</b>
<b>LINE DRAWINGS</b> .....	<b>15</b>
<b>AMPLIFIERS</b> .....	<b>16 - 21</b>
<u>Descriptions</u>	
<u>ON / OFF</u>	
<u>Overload indicator</u>	
<u>Equalisation</u>	
<u>Overheating</u>	
<u>Low mains voltage</u>	
<u>Current consumption</u>	
<u>Troubleshooting</u>	
<b>RIGGING SYSTEM</b> .....	<b>22 - 30</b>
<u>4 units mounting on a flatbed dolly</u>	
<u>Array mounting of groups of 4 units on a flatbed dolly</u>	
<u>Combination with other models and stacking systems</u>	
<u>Transporting</u>	
<b>ANNEX : Line connections: unbalanced and balanced</b> .....	<b>31</b>

**Cajas acústicas activas / Self-powered loudspeaker enclosures**

El signo de exclamación dentro de un triángulo indica la existencia de importantes instrucciones de operación y mantenimiento en la documentación que acompaña al producto. Conserve y lea todas estas instrucciones. Siga las advertencias. **ATENCIÓN:** Es un producto clase A, por lo que en entornos domésticos puede causar radio-interferencias, en cuyo caso el usuario tendrá que tomar las medidas oportunas. De acuerdo con EN55103-2, usar el equipo sólo en entornos E1, E2, E3 ó E4.



The exclamation point inside an equilateral triangle is intended to alert the users to the presence of important operating and maintenance (servicing) instructions in the literature accompanying the product. Heed all warnings. Follow all instructions. Keep these instructions.

**WARNING:** This is a class A product. In a domestic environment this product may cause radio interferences in which case the user may be required to take adequate measures.

Use this product only in E1, E2, E3 or E4 environments according to EN55103-2.

Do not remove mains connector ground, it is dangerous and illegal. Class I device. The product must be connected to a mains socket outlet with protective earth connection. Only use this equipment with an appropriate mains cord for your country.

No desconecte la tierra en el conector de alimentación pues es peligroso e ilegal. Equipo de Clase I. El producto debe ser conectado a un enchufe con toma de tierra. Sólo use este equipo con el cable de red de alimentación adecuado para su país.

El signo del rayo con la punta de flecha, alerta contra la presencia de voltajes peligrosos no aislados. Para reducir el riesgo de choque eléctrico, no retire la cubierta.



The lightning and arrowhead symbol warns about the presence of uninsulated dangerous voltage. To reduce the risk of electric shock, do not remove the cover.

No instale el aparato cerca de ninguna fuente de calor como radiadores, estufas u otros aparatos que produzcan calor. Debe instalarse siempre sin bloquear la libre circulación de aire por las aletas del radiador.

Do not install near any heat sources such as radiators, heat registers, stoves or other apparatus that produce heat. The circulation of air through the heatsink must not be blocked.

No exponga este equipo a la lluvia o humedad sin el protector de lluvia recomendado. No exponga el equipo a salpicaduras sin el protector de lluvia recomendado, ni coloque sobre él objetos que contengan líquidos, tales como vasos y botellas.

Do not expose this device to rain or moisture without the rain protector supplied. Do not place any objects containing liquids, such as bottles or glasses, on the top of the unit. Do not splash liquids on the unit without the rain protector supplied.

Este símbolo indica que el presente producto no puede ser tratado como residuo doméstico normal, sino que debe entregarse en el correspondiente punto de recogida de equipos eléctricos y electrónicos.



This symbol on the product indicates that this product should not be treated as household waste. Instead it shall be handed over to the applicable collection point for the recycling of electrical and electronic equipment.

Equipo diseñado para funcionar entre 15°C y 45°C con una humedad relativa máxima del 95%, con un rango de ±10% de la tensión nominal de alimentación indicada en la etiqueta trasera (según IEC 60065). Si debe sustituir el fusible preste atención al tipo y rango.

Working temperature ranges from 15°C to 45°C with a relative humidity of 95%, with ±10% of the rated main voltage value indicated on the rear label (according to IEC 60065). If the fuse needs to be replaced, please pay attention to correct type and ratings.

El cableado exterior conectado al equipo requiere de su instalación por una persona instruida o el uso de cables flexibles ya preparados.

The outer wiring connected to the device requires installation by an instructed person or the use of a flexible cable already prepared.

Si el aparato es conectado permanentemente, la instalación eléctrica del edificio debe incorporar un interruptor multipolar con separación de contacto de al menos 3mm en cada polo.

If the apparatus is connected permanently, the electrical system of the building must incorporate a multipolar switch with a separation of contact of at least 3mm in each pole.

Para desconectar el dispositivo debe usar el enchufe. Desconecte este aparato durante tormentas eléctricas, terremotos o cuando no se vaya a emplear durante largos periodos.

To disconnect the device, you should use the mains plug. Unplug this apparatus during lightning storms, earthquakes or when unused for long periods of time.

No emplace altavoces en proximidad a equipos sensibles a campos magnéticos, tales como monitores de televisión o material magnético de almacenamiento de datos.



Do not place loudspeakers in proximity to devices sensitive to magnetic fields such as television monitors or data storage magnetic material.

El colgado del equipo sólo debe realizarse utilizando los herrajes de colgado recomendados y por personal cualificado. No cuelgue la caja de las asas y respete los valores máximos de carga dados en el manual.

The appliance should be flown only from the rigging points and by qualified personnel. Do not suspend the box from the handles and respect the maximum load values given in the manual.

No existen partes ajustables por el usuario en el interior de este equipo. Cualquier operación de mantenimiento o reparación debe ser realizada por personal cualificado. Es necesario el servicio técnico cuando el equipo se haya dañado de alguna forma, como que haya caído líquido o algún objeto en el interior del aparato, haya sido expuesto a lluvia o humedad, no funcione correctamente, haya recibido un golpe o su cable de red esté dañado.

No user serviceable parts inside. Refer all servicing to qualified service personnel. Servicing is required when the apparatus has been damaged in any way, such as power-supply cord or plug is damaged, liquid has been spilled or objects have fallen into the apparatus, the apparatus has been exposed to rain or moisture, does not operate normally or has been dropped.

Limpie con un paño seco. No use limpiadores con disolventes.

Clean only with a dry cloth. Do not use any solvent based cleaners.

## **GARANTÍA**

Todos nuestros productos están garantizados por un periodo de 24 meses desde la fecha de compra.

Las garantías sólo serán válidas si son por un defecto de fabricación y en ningún caso por un uso incorrecto del producto.

Las reparaciones en garantía pueden ser realizadas, exclusivamente, por el fabricante o el servicio de asistencia técnica autorizado.

Otros cargos como portes y seguros, son a cargo del comprador en todos los casos.

Para solicitar reparación en garantía es imprescindible que el producto no haya sido previamente manipulado e incluir una fotocopia de la factura de compra.

## **WARRANTY**

All our products are warranted against any manufacturing defect for a period of 2 years from date of purchase.

The warranty excludes damage from incorrect use of the product.

All warranty repairs must be exclusively undertaken by the factory or any of its authorised service centers.

To claim a warranty repair, do not open or intend to repair the product.

Return the damaged unit, at shippers risk and freight prepaid, to the nearest service center with a copy of the purchase invoice.



## DECLARACIÓN DE CONFORMIDAD DECLARATION OF CONFORMITY

### **DAS Audio Group, S.L.**

C/ Islas Baleares, 24 - 46988 - Pol. Fuente del Jarro - Valencia. España  
(Spain).

Declara que la serie Event:  
Declares that Event series:

Cumple con los objetivos esenciales de las Directivas:  
Abide by essential objectives relating Directives:

- Directiva de Baja Tensión (Low Voltage Directive) 2014/35/UE
- Directiva de Compatibilidad Electromagnética (EMC) 2014/30/UE
- Directiva RoHS 2011/65/UE
- Directiva RAEE (WEEE) 2012/19/UE

Y es conforme a las siguientes Normas Armonizadas Europeas:  
In accordance with Harmonized European Norms:

- EN 60065:2014.- Audio, video and similar electronic apparatus. Safety requirements.
- EN 55032:2012.- Electromagnetic compatibility of multimedia equipment. Emission requirements.
- EN 55103-2:2009.- Electromagnetic compatibility. Product family standard for audio, video, audio-visual and entertainment lighting control apparatus for professional use. Part 2:Immunity.
- EN 50581:2012.- Technical documentation for the assessment of electrical and electronic products with respect to the restriction of hazardous substances.

## INTRODUCTION

For portable live sound applications, or fixed installations in almost any type of venue, the Event Line Arrays have been designed to provide exceptional sound, steadfast reliability and value beyond comparison.

Also, the Event Line Arrays incorporate high frequency waveguides designed with the same technology as the aero series. The Event series is expanded with two satellites: EVENT-212A and EVENT-212.120A, and a subwoofer: EVENT-121A, to provide a complete solution for all your Events.

### Features

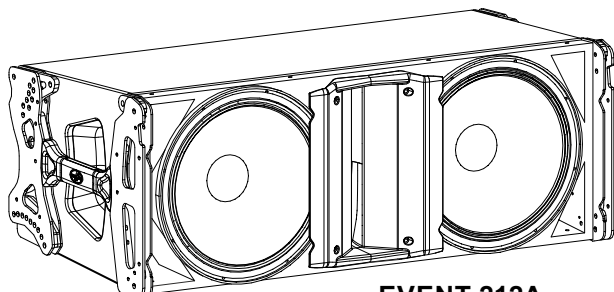

**EVENT-212A**

### EVENT-212A

- Powered 3-way line array system
- Class D amplifier 3 x 1000 W<sub>peak</sub>
- DAScontrol™ Interface for fast setup
- High-end DSP chipsets with FIR filters
- 2 x 12", 12MI4, loudspeakers in dual band configuration
- 1 x M-75 compression driver, 3" VCD
- 90° wide coverage
- Top grade Birch cabinet construction
- Robust quick-rig professional rigging hardware

The EVENT-212A is a powered, 3-way line array which employs two 12" loudspeakers in a dual band configuration where each speaker operates in a specific frequency range. At low frequencies, the speakers work in tandem for maximum power, each driven by a dedicated amplifier channel providing 1000 W<sub>peak</sub> output power.

The loudspeaker units have been teamed up with a single M-75 compression driver and purpose-designed injected aluminum high frequency waveguide to provide unmatched performance, sensitivity and coverage in the formats offered.

The EVENT-212A line array incorporates the DAScontrol™ interface which offers a quick and hassle-free set-up of the systems in arrays and easy alignment with the EVENT-218A and EVENT-121A subwoofer systems. Presets for the number of units of the array, HF compensation for throw distances, and correction for the splay angle of the array can be selected by way of DAScontrol™ and the LCD screen on the located on the back of the cabinet.

The powerful digital signal processing of the EVENT-212A includes Finite Impulse Response (FIR) filters providing linear phase response and precise impulse response which in terms of performance, results in added clarity, defined attack in percussion and overall, a more natural sound.

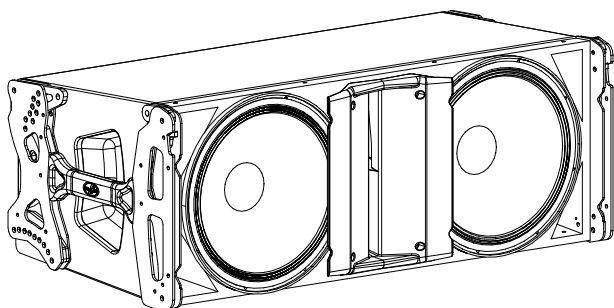

**EVENT-212.120A**

### EVENT-212.120A

- Powered 3-way line array system
- Class D amplifier 3 x 1000 W<sub>peak</sub>
- DAScontrol™ Interface for fast setup
- High-end DSP chipsets with FIR filters
- 2 x 12", 12MI4, loudspeakers in dual band configuration
- 1 x M-75 compression driver, 3" VCD
- 120° wide coverage
- Top grade Birch cabinet construction
- Robust quick-rig professional rigging hardware

The EVENT-212.120A is a powered, 3-way line array which employs two 12" loudspeakers in a dual band configuration where each speaker operates in a specific frequency range. At low frequencies, the speakers work in tandem for maximum power, each driven by a dedicated amplifier channel providing 1000 W<sub>peak</sub> output power.

The loudspeaker units have been teamed up with a single M-75 compression driver and purpose-designed injected aluminum high frequency waveguide to provide unmatched performance, sensitivity and coverage in the formats offered.

The EVENT-212.120A line array incorporates the DAScontrol™ interface which offers a quick and hassle-free set-up of the systems in arrays and easy alignment with the EVENT-218A and EVENT-121A subwoofer systems. Presets for the number of units of the array, HF compensation for throw distances, and correction for the splay angle of the array can be selected by way of DAScontrol™ and the LCD screen on the located on the back of the cabinet.

The powerful digital signal processing of the EVENT-212.120A includes Finite Impulse Response (FIR) filters providing linear phase response and precise impulse response which in terms of performance, results in added clarity, defined attack in percussion and overall, a more natural sound.

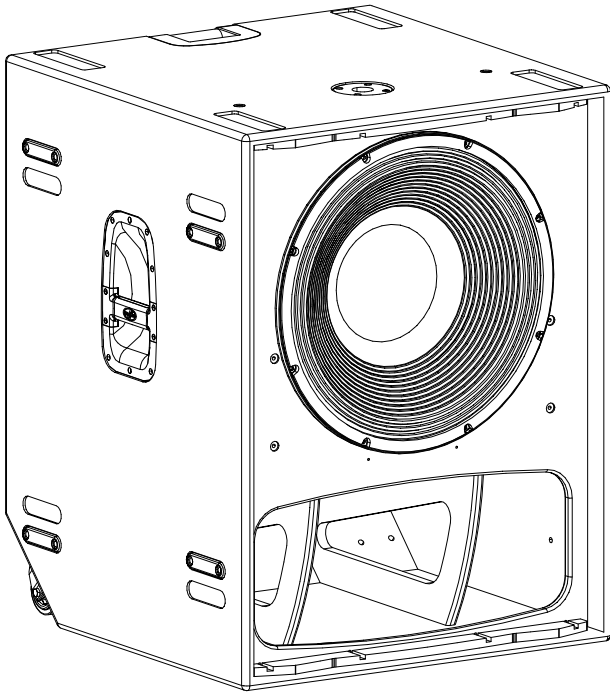

### EVENT-121A

- Active direct radiating rear-loaded subwoofer system
- 1 x 21", 21LFN, neodymium loudspeaker
- 3200W<sub>peak</sub> – 1600 W<sub>continuous</sub>
- Class D amplifier and digital signal processing (DSP)
  - Two balanced inputs with stereo filtered output connections
  - Variable low-pass filter 63 Hz-100 Hz
  - Top located pole mount socket for TRD-6 optional pole mount
- Rear located wheels to ease transport
- Top grade Birch cabinet construction
- Durable ISO-flex finish

### **EVENT-121A**

The EVENT-121A is a direct radiating rear-loaded powered subwoofer system which incorporates a single 21" neodymium loudspeaker providing "earth-moving" low-frequency reproduction for the Event Series line arrays. The combination of direct radiation and rear-loading provides a high output, tight and accurate sub-bass response.

The EVENT-121A employs the new 21LFN loudspeaker which offers impressive features such as a 4" sandwich split winding voice coil, a powerful FEA optimized neodymium magnet assembly and a FEA optimized suspension system with double silicon spider. The result is a loudspeaker with exceptional sensitivity, high power handling capacity and a quality suspension design capable of withstanding the stress and mechanical fatigue of today's high-power pro audio systems. An aluminum demodulating ring benefits lower distortion and effective forced ventilation of the voice coil gap provides for a high thermal rating, and reduced power compression.

The EVENT-121A electronics package includes a 3200 W<sub>peak</sub> Class D amplifier and 24-bit high-end DSP for top quality audio reproduction. On the rear panel, controls can be found for gain, polarity and a continually variable low-pass filter which ranges from 63 Hz to 100 Hz. A unique "cardioid preset" button simplifies the use of subs in cardioid configurations, making setup of two to three units a snap without the need for an external DSP. The EVENT-121A is phase response coherent with the EVENT-208A, EVENT-210A and EVENT-212A active tops offering precise alignment. Two balanced inputs with stereo filtered outputs which can be switched to pass-through connections are provided.

## CONFIGURATIONS

### 10xEVENT-212A + 2xEVENT-212.120A + 6xEVENT-218A

Use the same "number of units"  
value in all enclosures

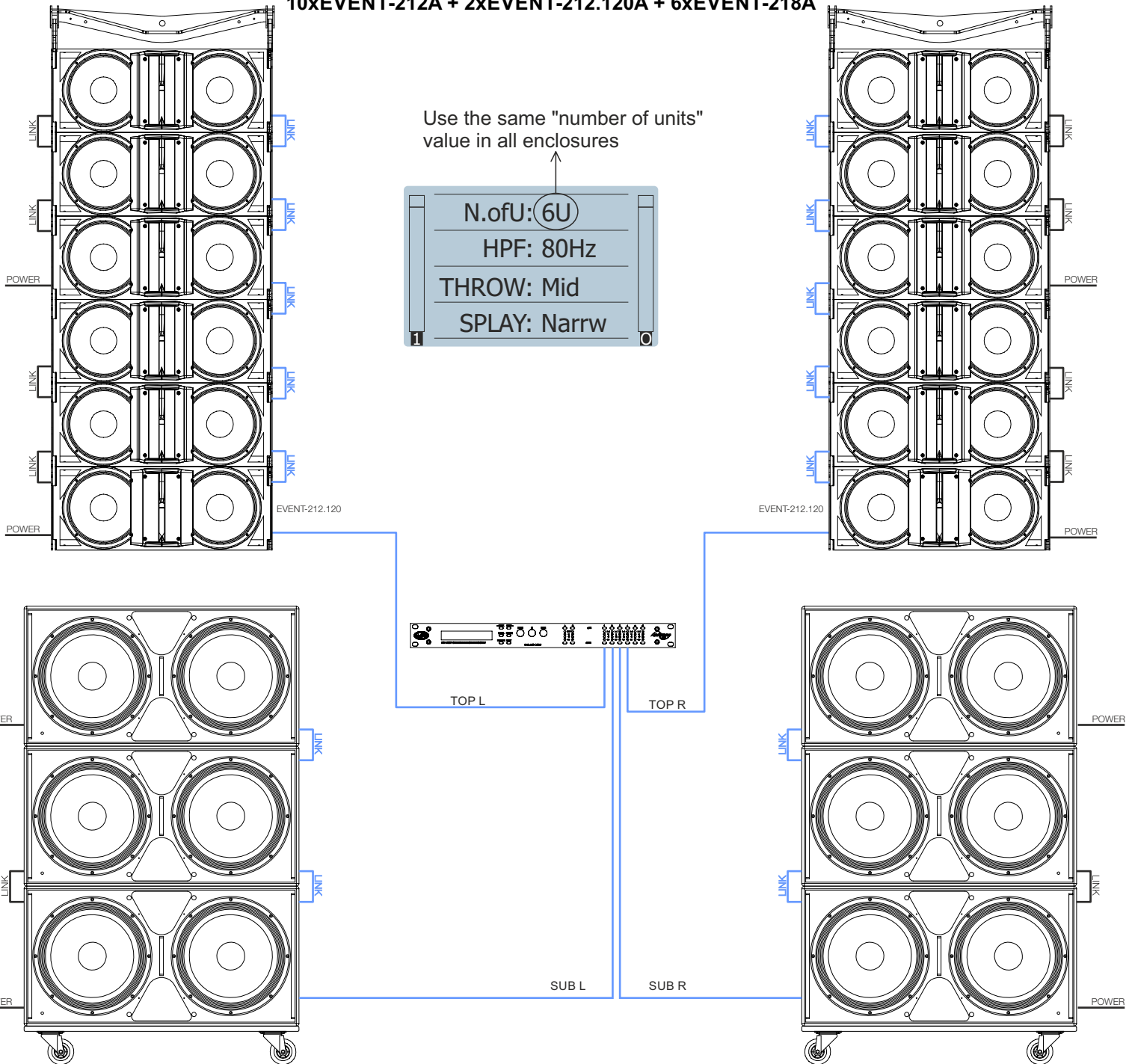
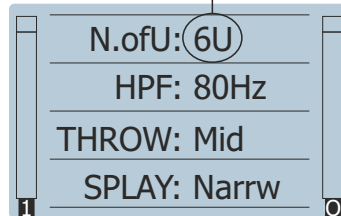

#### Processors

**DSP-2060A** 2 In/6 Out fully configurable DSP, 9 full bandwidth parametric band EQ on each channel, AudioCore/DASnet equipped

Units

1

#### Speaker cabling

**SC-1** 1m XLR microphone signal balanced cable

14

**PWCONLINK-09** 0.9m powerCON "jumper" NAC3FCB cable

10

#### Rigging frames

**AX-EV212** Rigging bumper for EVENT-212A (max 16 u.)

2

#### Dollies

**PL-EV218S** Plywood transport dolly for EVENT-218A (max 4 u.)

2

**PL-EV212S** Steel transport dolly for EVENT-212A/EVENT-212.120A (max 4 u.)

3



**CONFIGURATIONS (cont'd)**

**12xEVENT-212A + 4xEVENT-212.120A + 8xEVENT-218A**

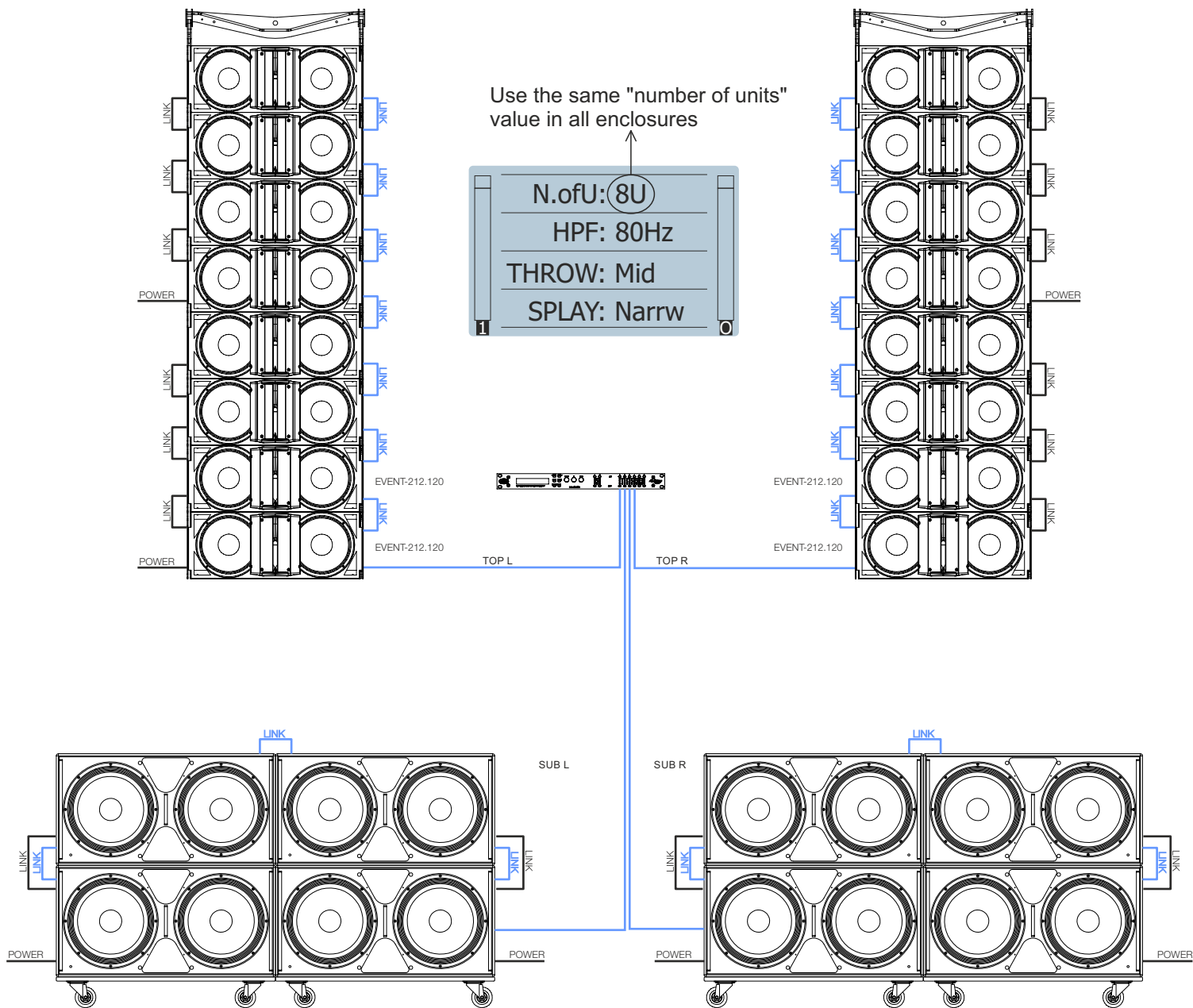

**Processors** **Units**

**DSP-2060A** 2 In/6 Out fully configurable DSP, 9 full bandwidth parametric band EQ on each channel, AudioCore/DASnet equipped 1

**Speaker cabling**

**SC-1** 1m XLR microphone signal balanced cable 18

**SC-2** 2m XLR microphone signal balanced cable 2

**PWCONLINK-09** 0.9m powerCON "jumper" NAC3FCB cable 16

**Rigging frames**

**AX-EV212** Rigging bumper for EVENT-212A (max 16 u.) 2

**Dollies**

**PL-EV218S** Plywood transport dolly for EVENT-218A (max 4 u.) 4

**PL-EV212S** Steel transport dolly for EVENT-212A/EVENT-212.120A (max 4 u.) 4

## CONFIGURATIONS (cont'd)

### 20xEVENT-212A + 4xEVENT-212.120A + 12xEVENT-218A

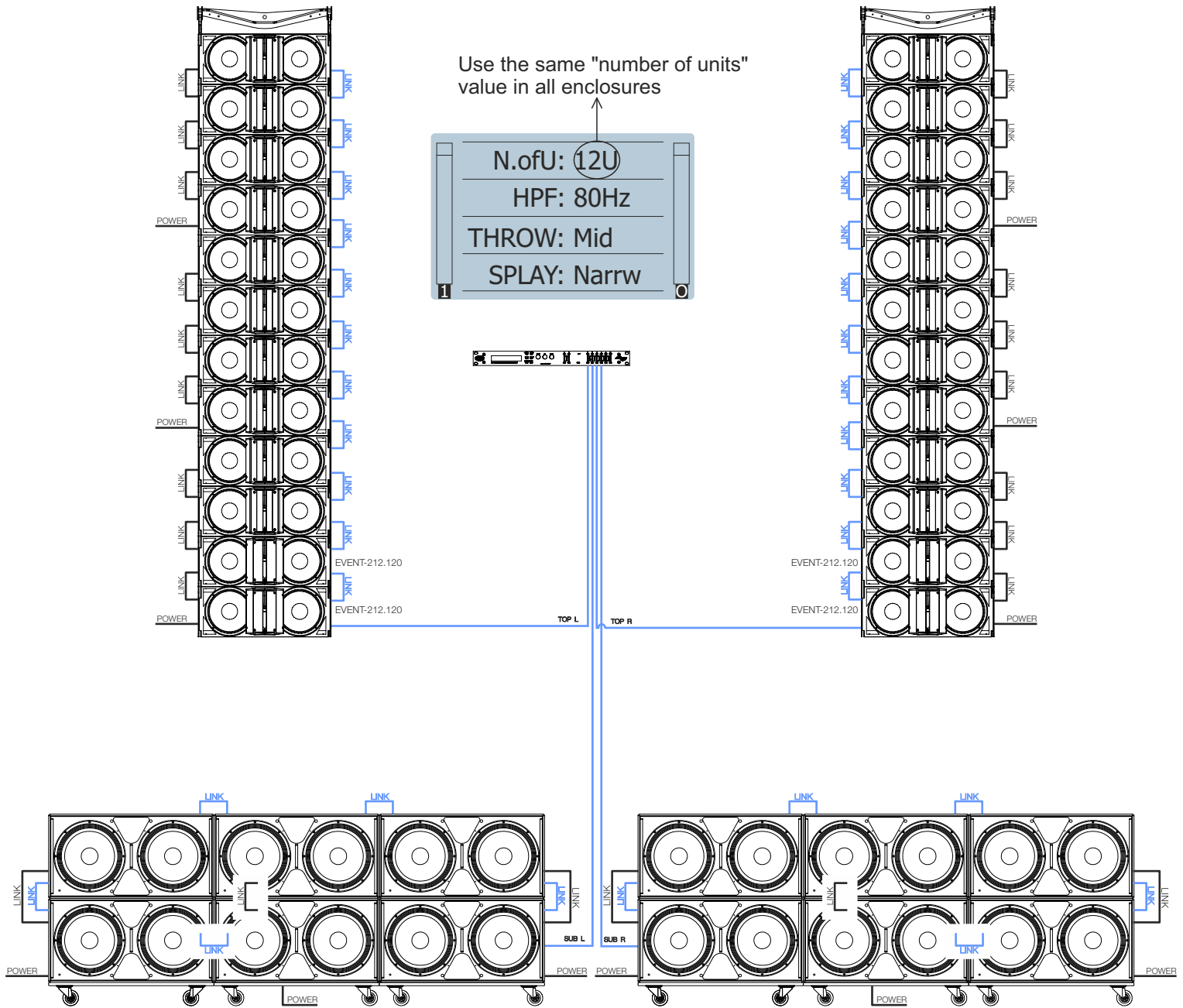

#### Processors

**DSP-2060A** 2 In/6 Out fully configurable DSP, 9 full bandwidth parametric band EQ on each channel, AudioCore/DASnet equipped

Units

1

#### Speaker cabling

**SC-1** 1m XLR microphone signal balanced cable

28

**SC-2** 2m XLR microphone signal balanced cable

4

**PWCONLINK-09** 0.9m powerCON "jumper" NAC3FCB cable

24

#### Rigging frames

**AX-EV212** Rigging bumper for EVENT-212A (max 16 u.)

2

#### Dollies

**PL-EV218S** Plywood transport dolly for EVENT-218A (max 4 u.)

6

**PL-EV212S** Steel transport dolly for EVENT-212A/EVENT-212.120A (max 4 u.)

6

## CONFIGURATIONS (cont'd)

### 10xEVENT-212A + 2xEVENT-212.120A + 4xEVENT-121A

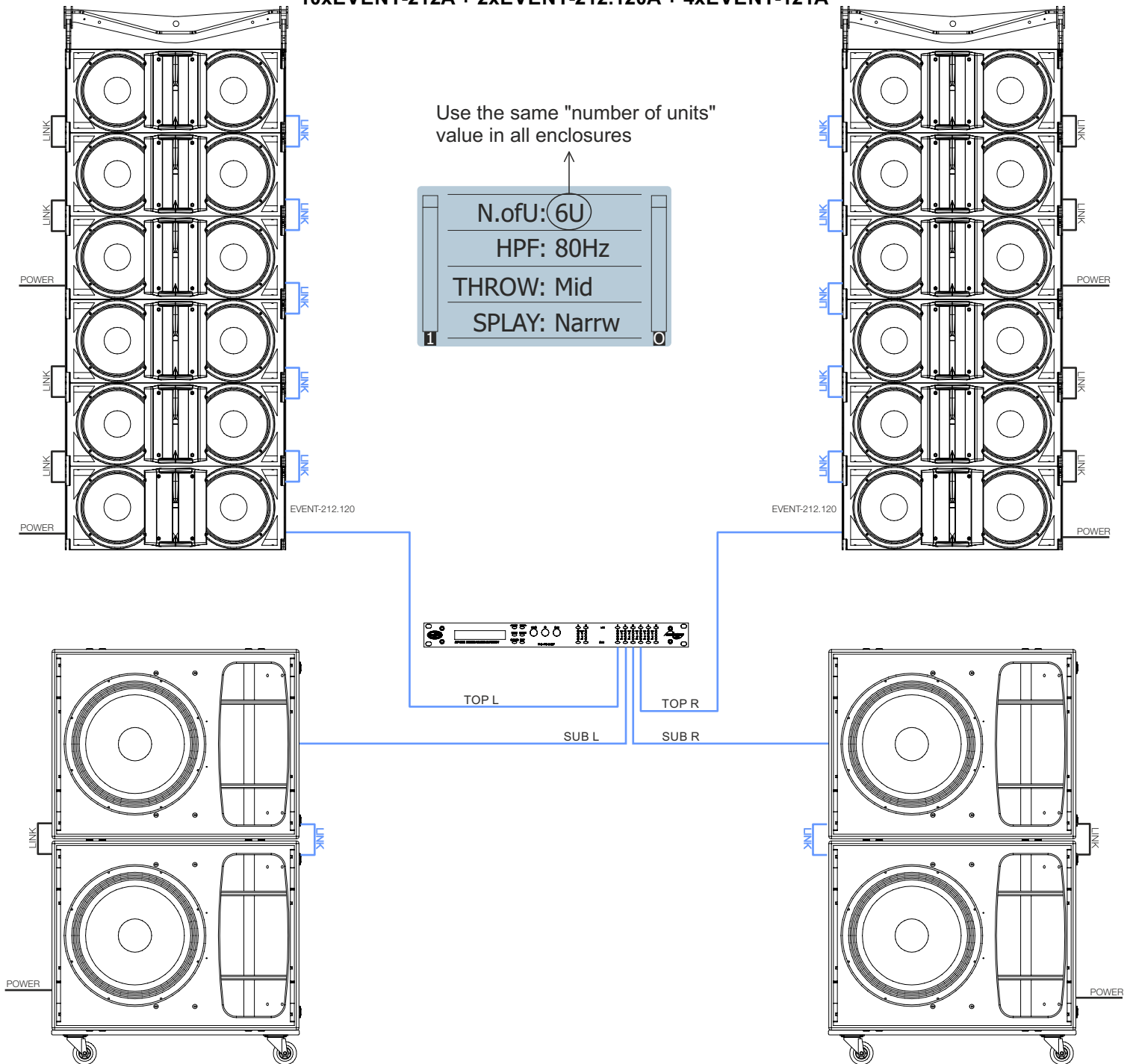

#### Processors

**DSP-2060A** 2 In/6 Out fully configurable DSP, 9 full bandwidth parametric band EQ on each channel, AudioCore/DASnet equipped

Units

1

#### Speaker cabling

**SC-1** 1m XLR microphone signal balanced cable

10

**PWCONLINK-09** 0.9m powerCON "jumper" NAC3FCB cable

10

#### Rigging frames

**AX-EV212** Rigging bumper for EVENT-212A (max 16 u.)

2

#### Dollies

**PL-EV121S** Wooden transport dolly for EVENT-121A (max 3 u.)

2

**PL-EV212S** Steel transport dolly for EVENT-212A/EVENT-212.120A (max 4 u.)

3

## CONFIGURATIONS (cont'd)

### 12xEVENT-212A + 4xEVENT-212.120A + 6xEVENT-121A

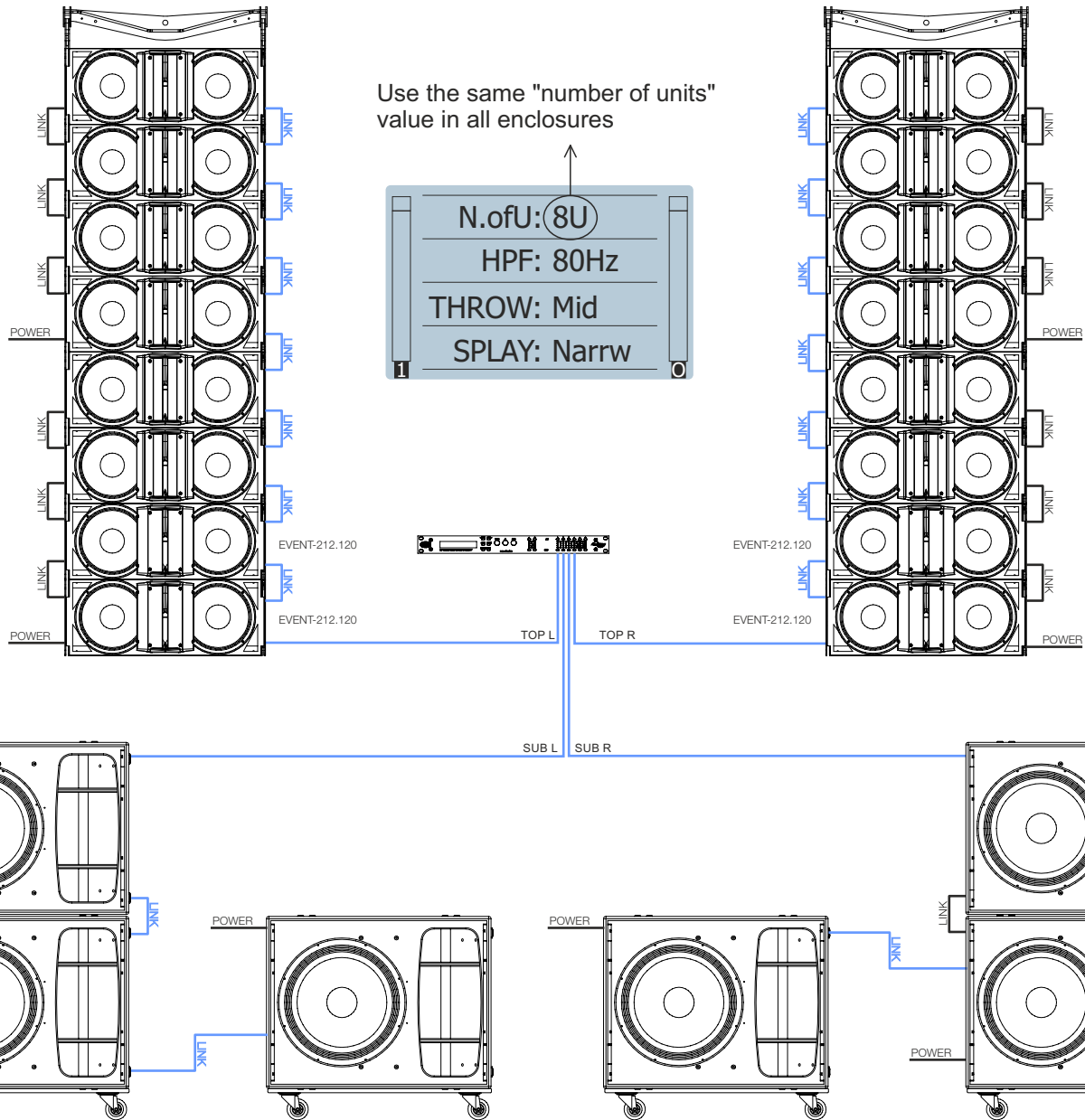

#### Processors

**DSP-2060A** 2 In/6 Out fully configurable DSP, 9 full bandwidth parametric band EQ on each channel, AudioCore/DASnet equipped

Units

1

#### Speaker cabling

**SC-1** 1m XLR microphone signal balanced cable

16

**SC-2** 2m XLR microphone signal balanced cable

2

**PWCONLINK-09** 0.9m powerCON "jumper" NAC3FCB cable

14

#### Rigging frames

**AX-EV212** Rigging bumper for EVENT-212A (max 16 u.)

2

#### Dollies

**PL-EV121S** Wooden transport dolly for EVENT-121A (max 3 u.)

4

**PL-EV212S** Steel transport dolly for EVENT-212A/EVENT-212.120A (max 4 u.)

4

## CONFIGURATIONS (cont'd)

### 20xEVENT-212A + 4xEVENT-212.120A + 8xEVENT-121A

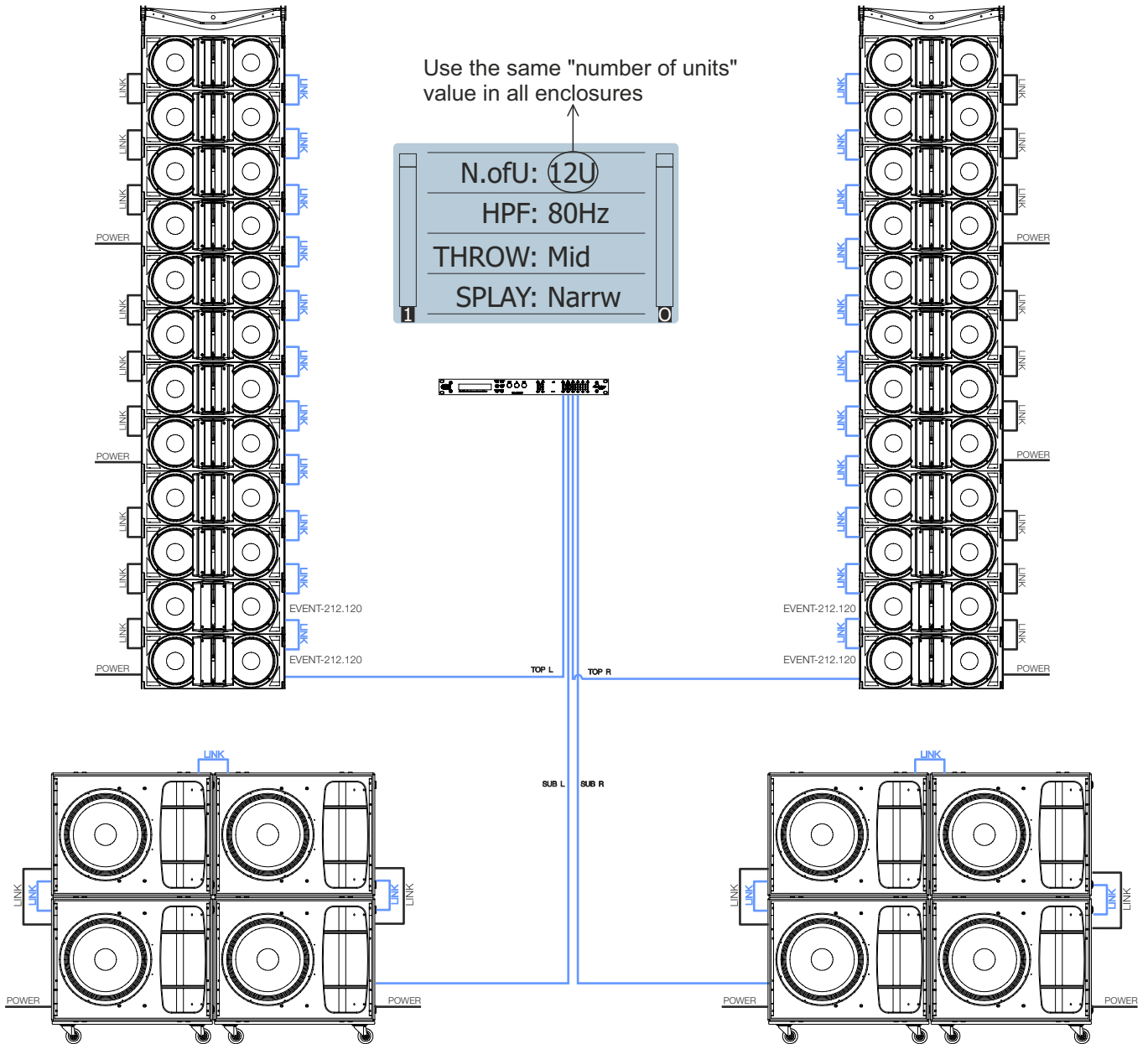

#### Processors

**DSP-2060A** 2 In/6 Out fully configurable DSP, 9 full bandwidth parametric band EQ on each channel, AudioCore/DASnet equipped

Units

1

#### Speaker cabling

**SC-1** 1m XLR microphone signal balanced cable

26

**SC-2** 2m XLR microphone signal balanced cable

2

**PWCONLINK-09** 0.9m powerCON "jumper" NAC3FCB cable

22

#### Rigging frames

**AX-EV212** Rigging bumper for EVENT-212A (max 16 u.)

2

#### Dollies

**PL-EV121S** Wooden transport dolly for EVENT-121A (max 3 u.)

4

**PL-EV212S** Steel transport dolly for EVENT-212A/EVENT-212.120A (max 4 u.)

6

## SPECIFICATIONS

Model	EVENT-212A	EVENT-212.120A	EVENT-121A
Nominal LF Power Amplifier	1000W <sub>peak</sub> - 500 W <sub>continuous</sub>	1000W <sub>peak</sub> - 500 W <sub>continuous</sub>	3200W <sub>peak</sub> - 1600 W <sub>continuous</sub>
Nominal MF Power Amplifier	1000W <sub>peak</sub> - 500 W <sub>continuous</sub>	1000W <sub>peak</sub> - 500 W <sub>continuous</sub>	---
Nominal HF Power Amplifier	1000W <sub>peak</sub> - 500 W <sub>continuous</sub>	1000W <sub>peak</sub> - 500 W <sub>continuous</sub>	---
Input Type	Balanced Differential Line	Balanced Differential Line	Balanced Differential Line
Input Impedance	Line: 20 kohms	Line: 20 kohms	Line: 20 kohms
Sensitivity	Line: 6.2 V (+18 dBu)	Line: 6.2 V (+18 dBu)	Line: 6.2 V (+18 dBu)
Frequency Range (-10 dB)	60 Hz -20 kHz	60 Hz -20 kHz	30 Hz -125 Hz
Horizontal Coverage (-6dB)	90° Nominal	120° Nominal	---
Vertical Coverage	Splay Dependent	Splay Dependent	---
Rated Maximum Peak SPL at 1 m <sup>(1)</sup>	135 dB	134 dB	141 dB
Transducers/Replacement Parts	LF: 1 x 12MI4/GM-12MI4 MF: 1 x 12MI4/GM-12MI4 HF: 1 x M-75/GM-M75N	LF: 1 x 12MI4/GM-12MI4 MF: 1 x 12MI4/GM-12MI4 HF: 1 x M-75/GM-M75N	LF: 1 x 21LFN /GM-21LF
Enclosure Geometry	Trapezoidal 5°	Trapezoidal 5°	Rectangular
Enclosure Material	Birch Plywood	Birch Plywood	Birch Plywood
Color/Finish	Black Polyurea Paint	Black Polyurea Paint	Black Polyurea Paint
Rigging System Splay Angles	Integrated in box design	Integrated in box design	---
Connectors	INPUT: 1 x Female XLR LOOP THRU: 1 x Male XLR AC INPUT: 1 x powerCON NAC3FCA AC OUTPUT: 1 x powerCON NAC3FCB	INPUT: 1 x Female XLR LOOP THRU: 1 x Male XLR AC INPUT: 1 x powerCON NAC3FCA AC OUTPUT: 1 x powerCON NAC3FCB	INPUT: 2 x Female XLR OUTPUT: 2 x Male XLR AC INPUT: 1 x powerCON NAC3FCA AC OUTPUT: 1 x powerCON NAC3FCB
AC Power Requirements	115 V, 3.6A, 50 Hz/60 Hz 230 V, 1.8A, 50 Hz/60 Hz	115 V, 3.6A, 50 Hz/60 Hz 230 V, 1.8A, 50 Hz/60 Hz	115 V, 7.2A, 50 Hz/60 Hz 230 V, 3.6A, 50 Hz/60 Hz
Dimensions (H x W x D)	322 x 851 x 432 mm 12.7 x 33.5 x 17 in	322 x 851 x 432 mm 12.7 x 33.5 x 17 in	961 x 739 x 753 mm 37.8 x 29.1 x 29.7 in
Weight	40.5 kg (89 lb)	40.5 kg (89 lb)	75 kg (165 lb)
Accessories	AX-EV212 Rigging System AXS-EV212 Stacking Base FUN-4-EV212 Transport Cover PL-EV212S Stacking Dolly PICKUP-AX-EV212 AX-COMBOEV1208 AX-COMBOEV1210	AX-EV212 Rigging System AXS-EV212 Stacking Base FUN-4-EV212 Transport Cover PL-EV212S Stacking Dolly PICKUP-AX-EV212 AX-COMBOEV1208 AX-COMBOEV1210	TRD-6 AXS-EV210 Stacking Base FUN-2-EV121 PL-EV121S

(1). Maximum calculated Peak SPL based on sensitivity and RMS power handling.

**DAS Audio Group, S.L.** continuously strives to enhance its products through investigation and development. All specifications are subject to change without prior notice.

LINE DRAWINGS

ALL DIMENSIONS IN MILLIMETERS

EVENT-212A / EVENT-212.120A

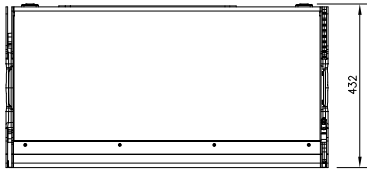

Top View

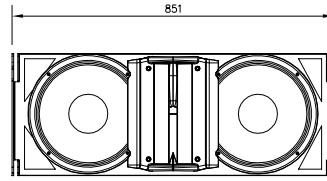

Frontal View : EVENT-212A

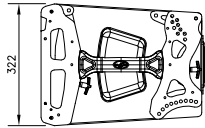

Right View

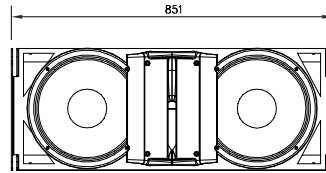

Frontal View : EVENT-212.120A

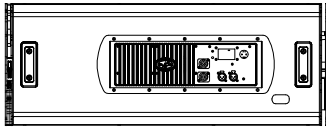

Rear View

EVENT-121A

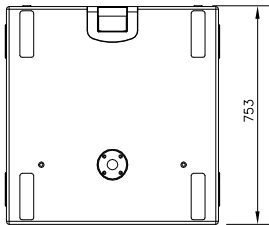

Top View

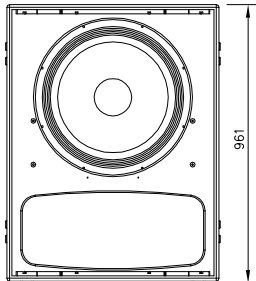

Frontal View

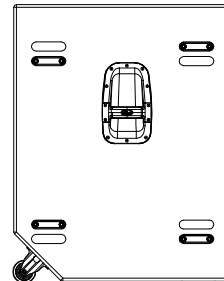

Left View

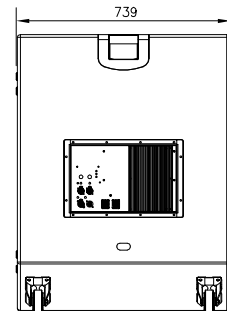

Rear View

## AMPLIFIERS

### EVENT-121A amplifier

#### 1) INPUT :

1/4" Jack+XLR combined socket-type input signal connector. This is a balanced connector just like the OUTPUT connector with the following pin assignments:

1 or S =GND (ground) 2 or T =(+) Non inverted input 3 or R =(-) Inverted input

#### 2) OUTPUT :

A and B, XLR-type output signal connectors for connecting several units together and sending them all the same input signal or filtered signal (by using HPF/THRU).

#### 3) LIMIT :

Red LED indicates amplifier saturation. Amplifier limiter indicator lights.

#### 4) SIGNAL :

Green LED indicates signal presence.

#### 5) ON :

Green LED indicates that the unit is ON.

#### 6) LEVEL :

Potentiometer for adjusting the unit level.

#### 7) LOW-PASS :

Button for adjusting the upper cut-off frequency for the subwoofer unit. We recommend a cut-off frequency of 80 Hz.

#### 8) CARDIOID PRESET :

Press the button to select the Cardioid preset.

#### 9) POLARITY :

Switch for inverting the phase of the unit.

#### 10) AC INPUT :

PowerCon NAC3FCA mains connector (inserted, rotated and locked for ON). Only use this equipment with an appropriate mains cord.

#### 11) AC OUTPUT :

PowerCon NAC3FCB connector for AC loop thru (see unit's label)). Only use this equipment with an appropriate mains cord.

#### 12) HPF/THRU :

'SATELLITE OUTPUT' selector to switch between full range signal or pass filter with cut-off frequency of 100 Hz.

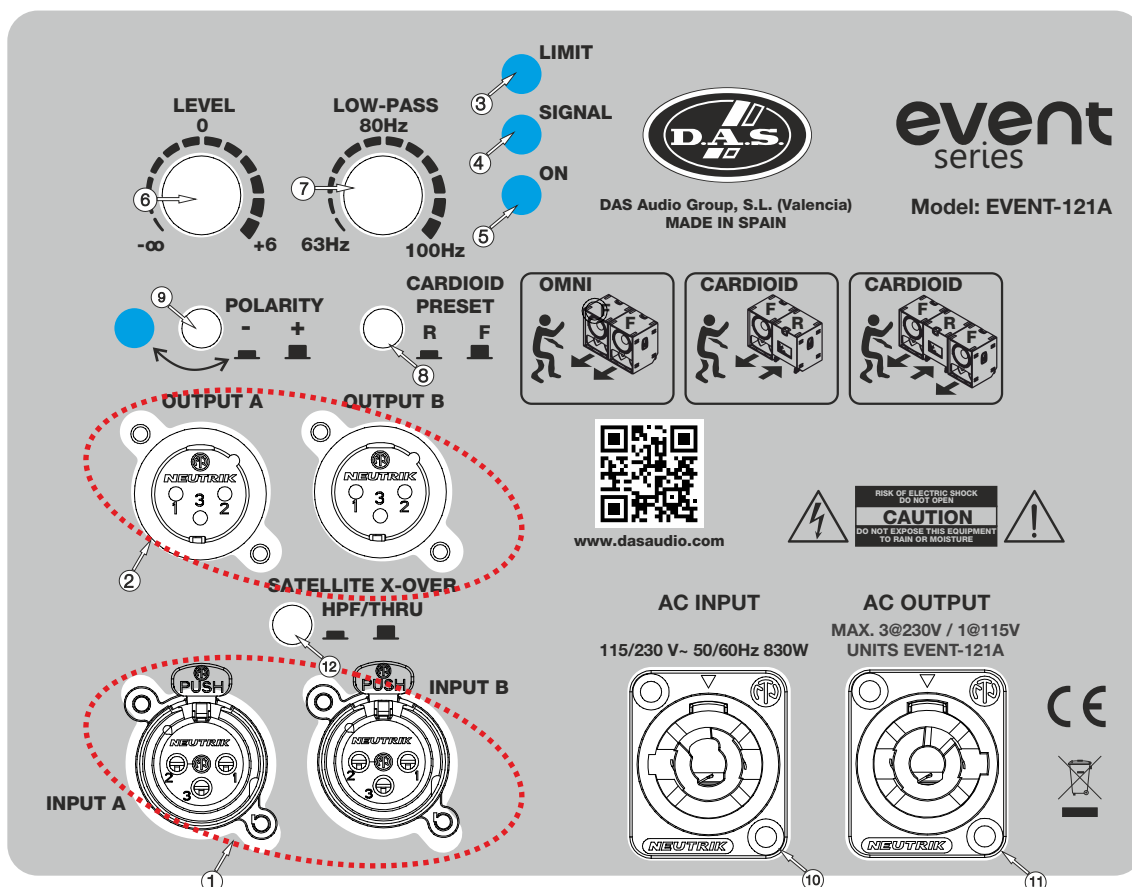



# EVENT-212A or EVENT-212.120A amplifier

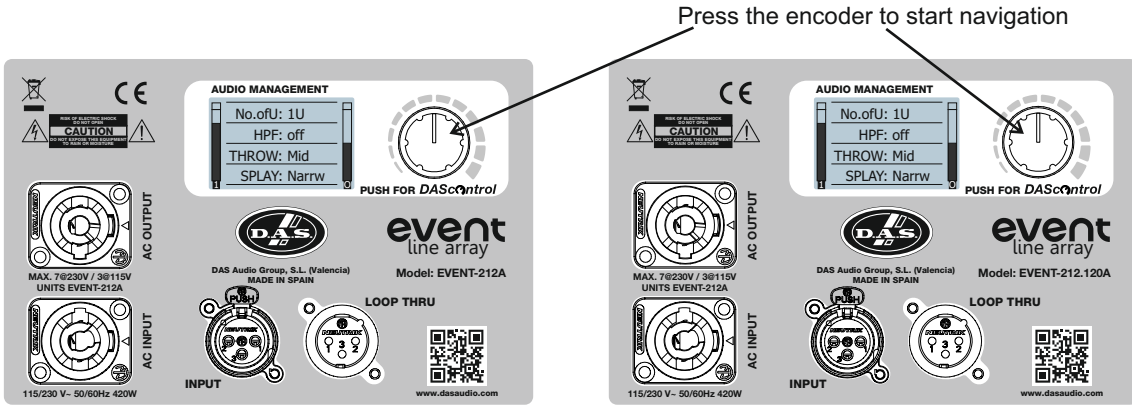

**Note:** The INPUT and LOOP THRU are type XLR balanced connectors.

By default the state of the parameters shown is the following. Keep in mind that any parameter changed in the DSP will remain with the same value until someone changes it again.

### AUDIO MANAGEMENT

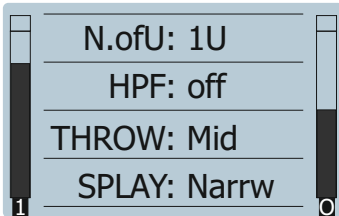

### ADJUSTING THE LEVELS

Once the input source has been connected to the amplifier's cabinet, the user has to check the gain structure of the system. Adjust level output from your processor and/or mixing console in order to prevent INPUT CLIP (left signal meter):

### AUDIO MANAGEMENT

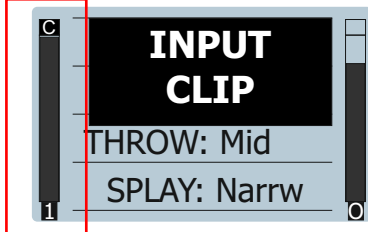

Exceeding the limits may cause damage in the system

As well, try to avoid excessive volume at the amplifier's output (right signal meter). Be sure that your gain structure is adequate and not causing amplifier LIMIT:

### AUDIO MANAGEMENT

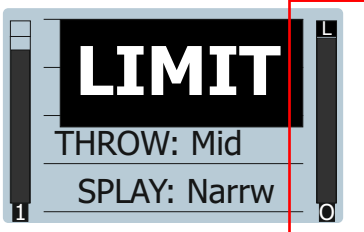

Exceeding the limits may cause damage in the system

### "N.ofU" (NUMBER OF UNITS)

The DAS array correction named Number Of Units is a parameter that compensates the amount of energy in the low-mid frequency range in the array:

### AUDIO MANAGEMENT

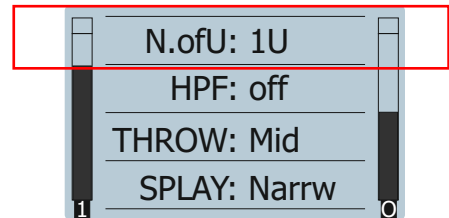

By pressing the encoder (DAScontrol) the user can have access to the menu:

### AUDIO MANAGEMENT

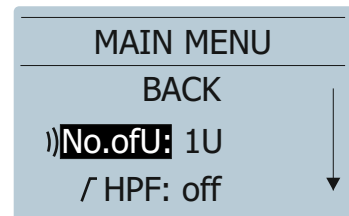

Rotate the encoder to the desired choice, in this case "No.ofU" and press to access all the options:

### AUDIO MANAGEMENT

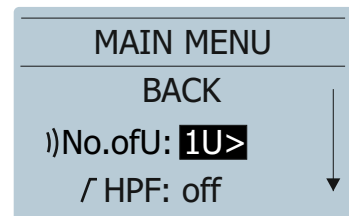

The available options for "No.ofU" are: 1, 2, 3, 4, 6, 8, 12, 16, depending on the size of the array. Rotate the encoder to select the option needed and press again to confirm.

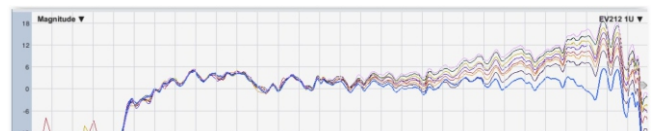

Use the same "Number Of Units" IN ALL the cabinets of your system!

## HPF (High Pass Filter)

By pressing the encoder (DAScontrol) the user can have access to the menu; rotate to navigate until selecting HPF:

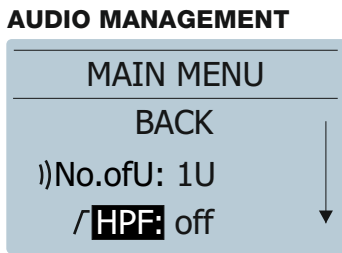

Press the encoder:

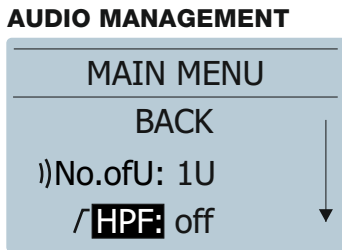

Rotate the encoder and press to confirm one of the following "HPF" options: off, 80Hz, 100Hz, 125Hz.

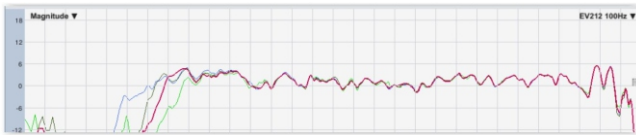

User MUST enable the SAME HPF in ALL cabinets forming the array!

In order to have more dynamic headroom in the system, when used with subs, HPF at 80Hz or 100Hz is highly recommended.

## THROW

Press the encoder and rotate it until "THROW" is shown in the display:

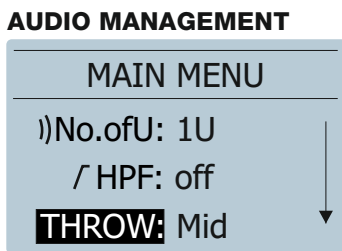

Press the encoder to enter into this field. There are 5 options available, "Long, L-Mid, Mid, Mid-S, Short".

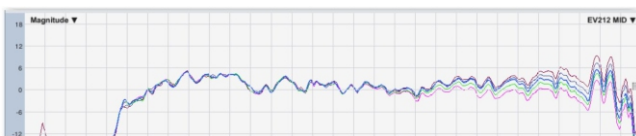

## SPLAY

Press the encoder and rotate it until "SPLAY" is shown in the display:

### AUDIO MANAGEMENT

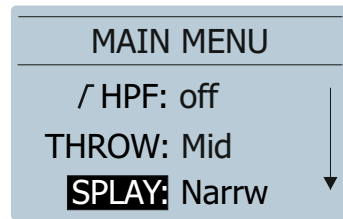

Depending on the array's "splay angles" or "curvature", there are 3 main modes: "Narrow" (typical J-shaped array), "Mid" (all cabinets at 4° or 5°) and "Wide" (for arrays with higher splay angles, 6° or 7° in all cabinets).  
USE THE SAME "SPLAY" CORRECTION IN ALL CABINETS!

Some examples of these configurations with Ease Focus 3:

### NARROW

Use this setting for any typical J-shaped array configuration.  
ALL cabinets with "SPLAY" in Narrow position.

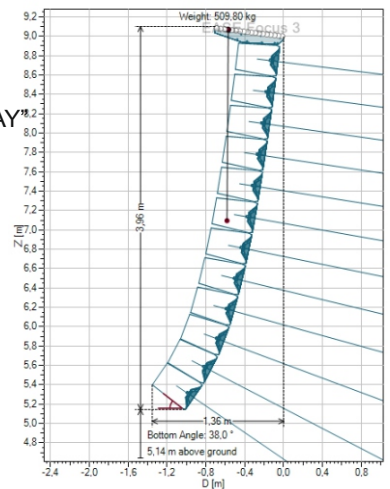

### MID

All cabinets at 4° or 5°. The correction of the "MID" preset boosts the energy at 1k25Hz with +2dB gain:

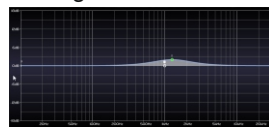

ALL cabinets with "SPLAY" in "MID" position.

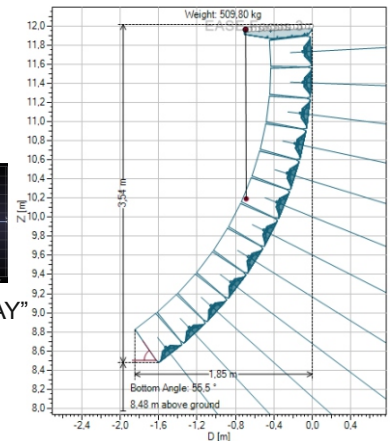

### WIDE

All cabinets at 6° or 7°. The correction of the "WIDE" preset boosts the energy at 1k25Hz with +4dB gain:

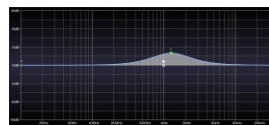

ALL cabinets with "SPLAY" in "WIDE" position.

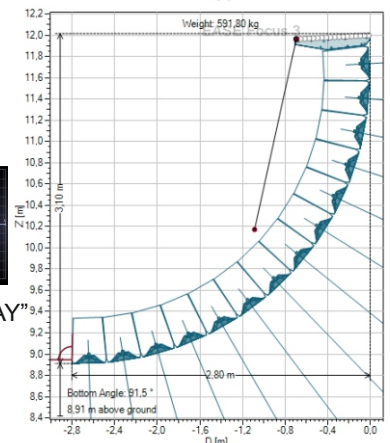

## OPTIONS

In this sub-menu the user can configure all the non-audio related options. Remember that in order to access each parameter it is necessary to push the encoder:

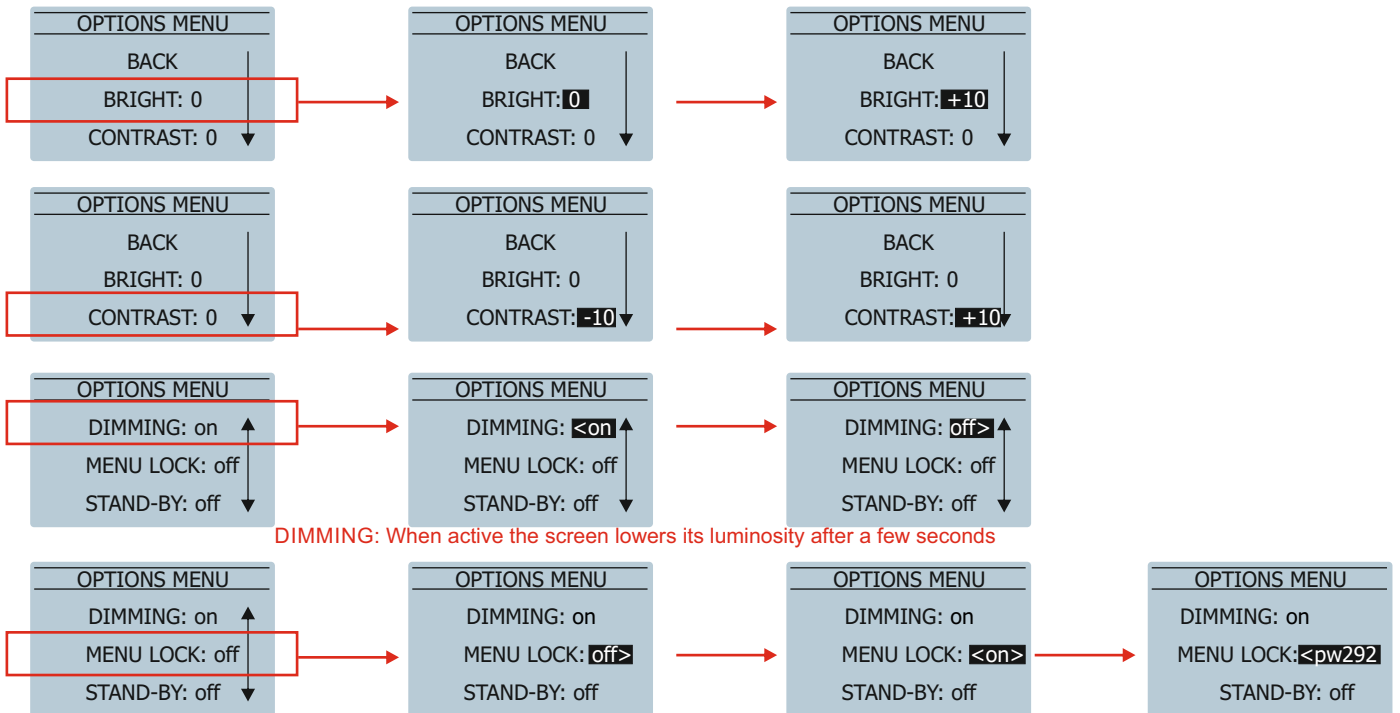
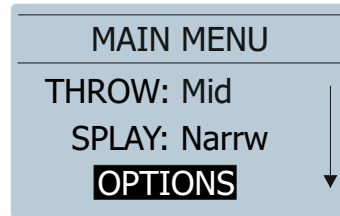

DIMMING: When active the screen lowers its luminosity after a few seconds

A. User can LOCK the Display and the encoder this option MENU LOCK: ON

B. User can LOCK the Display and the encoder WITH PASSWORD by enabling this option MENU LOCK: pw292

In case A to unlock just press the encoder:

In case B to unlock PUSH encoder and enter the 3 digit password (292):

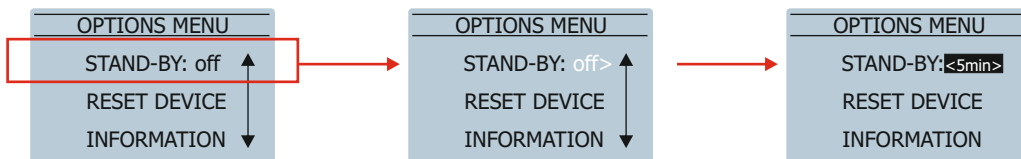
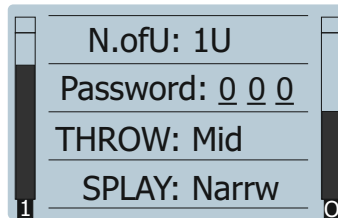
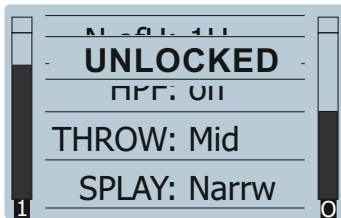

STAND-BY: When no signal is detected the amplifier shuts down. Time can be selected

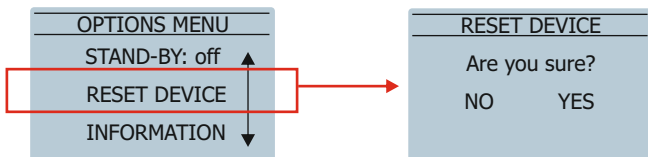

This option resets the device to the following values: No.ofU: 1U  
HPF: off  
THROW: Mid  
SPLAY: Narrw  
Stand-By: off  
Dimming: On

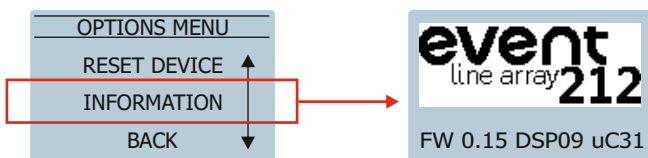

### **ON/OFF**

A sound system should be switched on sequentially. Switch on the self-powered units last in your sound system (switch on the subwoofer before the mid-high system). Switch on the sound sources such as CD players or turntables, then the mixer, then the processors, and finally the self-powered unit. If you have several units, it is recommended that you switch them on sequentially one at a time.

Follow the inverse order when switching off, turning self-powered units off before any other element in the sound system.

Disconnect the device by removing the mains connector from the mains socket. The mains connector and mains socket must always be freely accessible and never covered or blocked in any way.

The models use a power cable equipped with a Neutrik PowerCon NC3FCA connector. Power can be daisy chained via the NC3FCB output connector (see details on product label).

**IMPORTANT:** Do not disconnect the unit while in use.

Ensure that the device is disconnected from the mains by observing that the ON LED is turned off. Please note that the ON LED can stay on for several seconds after the mains power has been disconnected.

### **Overload indicator**

This device has an indicator (LIMIT LED) that lights when the signal is excessive.

The indicator should not be lit continuously. This distorts the signal (quickly fatiguing your ears) and may damage the speakers. Therefore, it is recommended that you never work with this LED on; at most it should blink only occasionally.

### **Equalisation**

The unit does not need extreme settings of equalisation to produce quality sound. Avoid high levels of gain on the equalisers. Gain values above +3 dB on a console's EQ are not recommended.

### **Overheating**

This equipment does not normally overheat during normal conditions of use. When overheating occurs, the unit protects itself. You should then find out why and if necessary contact an authorised dealer for technical assistance.

Normally it is enough just to let the unit cool down after you have corrected the problem so that the system functions properly again.

Keep grilles clean and dust-free.

Air circulates from the bottom to the top of the amplifier.

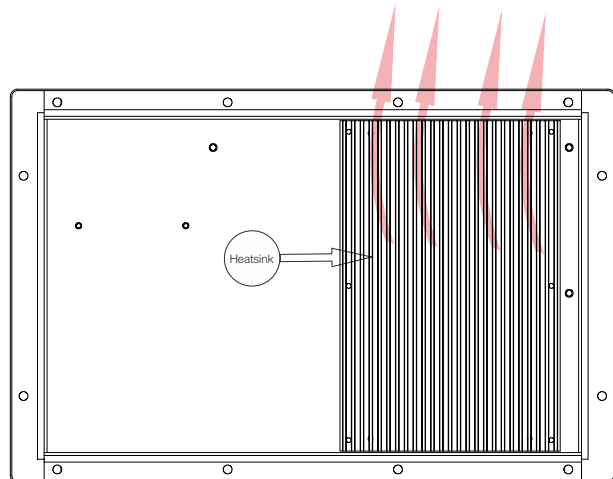

Heatsink of EVENT-121A amplifier

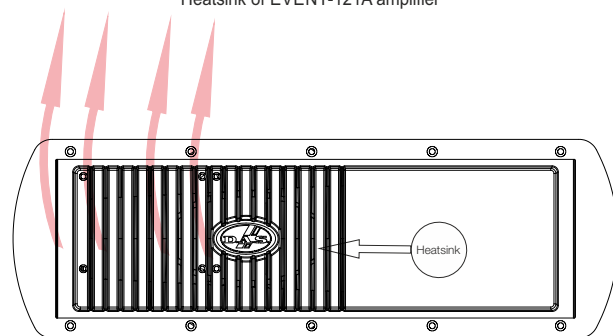

Heatsink of EVENT-212A and EVENT-212.120A amplifier

### **Low mains voltage**

If mains voltage falls below the shutdown voltage for the unit, it will stop playing. When acceptable levels are regained, the unit will switch back on automatically.

Therefore the current consumed by a 115V version is double the 230V version to achieve the same acoustic power level.

<i>Pink Noise Mains 230 Vrms</i>	1/3 Power
EVENT-212A	1.8A
EVENT-212.120A	1.8A
EVENT-121A	3.6A

## Troubleshooting

PROBLEM	CAUSE	SOLUTION
No sound from the unit. The SIGNAL LED does not light up.	<ol style="list-style-type: none"> <li>1 - The signal source is sending no signal.</li> <li>2 - Defective cable.</li> </ol>	<ol style="list-style-type: none"> <li>1 - Check that the mixer or sound source is sending signal to the UNIT.</li> <li>2 - Check that the cable from the sound source to the UNIT is connected correctly. Replace the cable if defective.</li> </ol>
Full power cannot be obtained. The LIMIT LED never lights up.	<ol style="list-style-type: none"> <li>1 - The signal source does not have a hot enough output.</li> <li>2 - The amplifier has overheated.</li> </ol>	<ol style="list-style-type: none"> <li>1 - If you use a mixer, be sure to use the balanced output if you have it. Use a professional mixer or signal source with more output level.</li> <li>2 - Try to cool the unit by lowering the level of the mixer. You can add an HPF to lower the temperature in low (cut at 100Hz, for example)</li> </ol>
Sound is distorted. The LIMIT LED is not on, or only lights up occasionally.	The mixer or signal source is distorting.	Turn mixer channel gains down. Check that none of your signal sources are distorting.
Sound is distorted and very loud and LIMIT LED lights up.	The system is overloaded and has reached maximum power.	Turn down the mixer's output.
Hum or buzz when a mixer is connected to the unit.	<ol style="list-style-type: none"> <li>1.- The console probably has un-balanced outputs. You may be using an incorrect un-balanced to balanced cable.</li> <li>2.- The mixer and the powered speaker are not plugged into the same mains outlet.</li> <li>3.- The audio signal cable is too long or too close to an AC cable</li> </ol>	<ol style="list-style-type: none"> <li>1.- Read the appendix of this manual to make a correct un-balanced to balanced cable.</li> <li>2.- Connect the mixer and the unit to the same mains outlet.</li> <li>3.- Use a cable that is as short as possible and/or move the audio signal cable away from mains cables.</li> </ol>
Hum or buzz when using lighting controls in the same building.	<ol style="list-style-type: none"> <li>1.- The audio signal cable is too long or too close to the lighting cable.</li> <li>2.- On a sound system with three-phase AC, the lighting equipment and the UNIT are connected to the same phase.</li> </ol>	<ol style="list-style-type: none"> <li>1.- Move the audio signal cable away from lighting cables. Try to find out at what point the noise is leaking into the system.</li> <li>2.- Connect the sound system to a different phase than the lights. You may need the help of an electrician.</li> </ol>
The ON LED does not light up when the mains connector is connected and the unit is switched to ON.	<ol style="list-style-type: none"> <li>1.- Bad or loose AC connection to the UNIT or the mains outlet.</li> <li>2- Faulty AC cable.</li> <li>3- Blown Fuse.</li> <li>4 - The mains voltage is out of range.</li> </ol>	<ol style="list-style-type: none"> <li>1.- Check your connections.</li> <li>2.- Check the cables, connectors and AC power with a suitable mains tester.</li> <li>3.- Replace the blown fuse for another of the same type and size.</li> <li>4.- If the multimeter determines that the mains voltage is out the range, you may need the assistance of an electrician to find an appropriate solution.</li> </ol>



### Warning

This manual offers all the necessary information for flying or stacking Event Line Array series systems of DAS Audio. This information is illustrated with drawings and required safety precautions.

To any operations related to flying a system, read the present document first and act on the warnings and advice given. The goal is to allow the user to become familiar with the mechanical elements required to fly the acoustic system, as well as the safety measures to be taken during set-up and teardown.

Only experienced installers with adequate knowledge of the equipment and local safety regulations should fly speaker boxes. It is the user's responsibility to ensure that the systems to be flown (including flying accessories) comply with state and local regulations.

The working load limits in this manual are the results of tests by independent laboratories. It is the user's responsibility to follow and comply with safety factors, resistance values, periodical supervisions and warnings given in this manual. Product improvement by means of research and development is on going at DAS Audio Group, S.L. Specifications are subject to change without notice.

It is common practice to apply 5:1 safety factors for enclosures and static elements. For slings and elements exposed to material fatigue due to friction and load variation the following ratios must be met; 5:1 for steel cable slings; 4:1 for steel chain slings and 7:1 for polyester slings. Thus, an element with a breaking load limit of 1000 kg may be statically loaded with 200 kg (5:1 safety factor) and dynamically loaded with 142 kg (7:1 safety factor).

When a system is flying, the working load must be lower than the resistance of each individual flying point in the enclosure, as well as each box. Hanging hardware should be regularly inspected and suspect units replaced if in doubt. This is important to avoid injury and absolutely no risks should be taken in this respect. It is highly recommended that you implement an inspection and maintenance program on flying elements, including reports to be filled out by the personnel that will carry out the inspections. Local regulations may exist that, in case of accident, may require you to prevent evidence of inspection reports and corrective actions after defects were found.

Absolutely no risks should be taken with regards to public safety.

When flying enclosures from ceiling support structures, extreme care should be taken to assure the load bearing capabilities of the structures so that the installation is absolutely safe. Do not fly enclosures from unsafe structures. Consult a certified professional if needed. All flying accessories that are not supplied by DAS Audio are the user's responsibility. Use at your own risk.

#### 4 units mounting on a flatbed dolly

Groups of three or four units are easy to transport by truck as we will see in this manual. We will also see the preparation with EVENT-212A (it's similar with EVENT-212.120A). But, such an extensive explanation isn't required for EVENT-121A, as this model can be used only in stacked systems lacking a rigging system (stacking up to 2 units on a PL-EV121S).

Once the packaging is removed, you can see three security pins on both enclosure sides (see figure), near the handles.

Now, you remove two security pins (see the red arrows in the Fig.1), on each side.

The top of platform PL-EV212S must be removed now (Fig.2, Fig.3 and Fig.4). We will save the pins and the top to place it at the end.

Lift the enclosure by the handles and sit it gently over the platform (Fig.5), aligning the holes for pins as shown in Fig.3.

Now, we insert the previously removed pins (the result is shown in Fig.6).



**Warning:** For transport, introduce the pin in hole 0° at "Rear Link" (both sides).



Trigger to unblock the front rod

These pins (PIN-8) should not be removed now

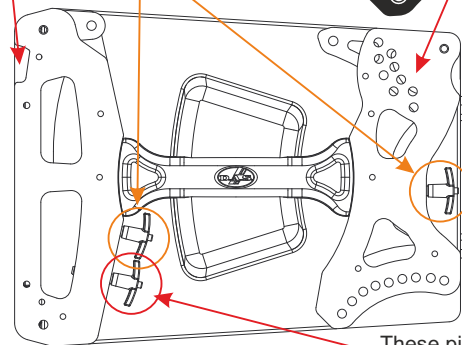

Fig.1

These pins (PIN-8) on each side must be removed

These pins (PIN-8) on each side must be removed

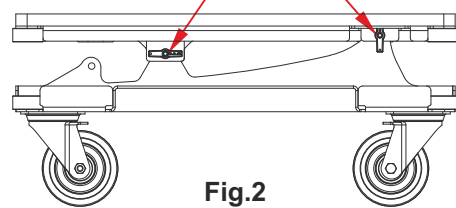

Fig.2

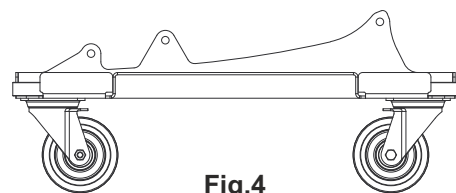

Fig.4

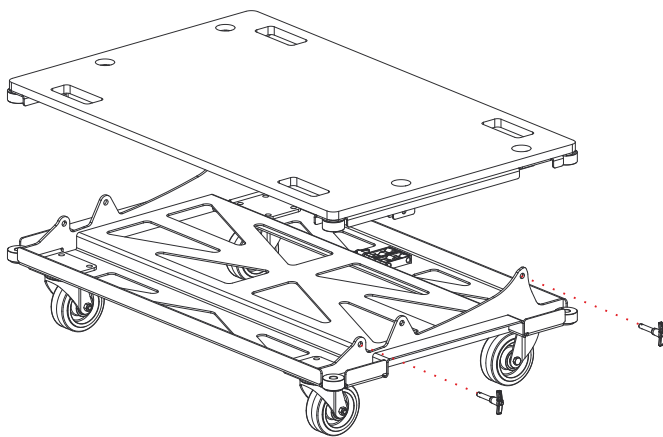

Fig.3

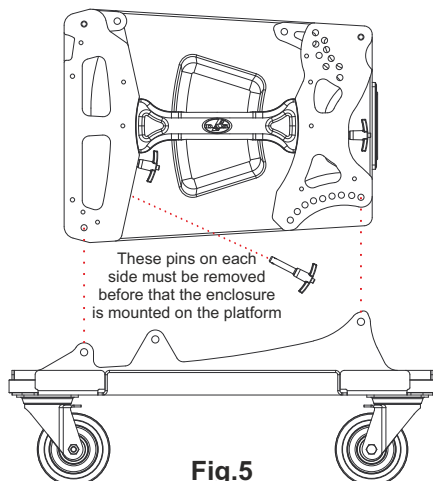

Fig.5

These pins on each side must be removed before that the enclosure is mounted on the platform

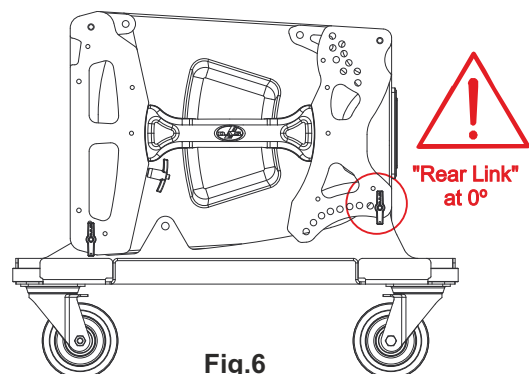

Fig.6



"Rear Link" at 0°

Now, once the first enclosure is placed on the platform, we will place the second.

To do this, previously we will lift the guides of both sides as indicated in Fig.7 (arrows in gray). Keep in mind that while the front is blocked (you will hear a "click" when blocked), the back will not.

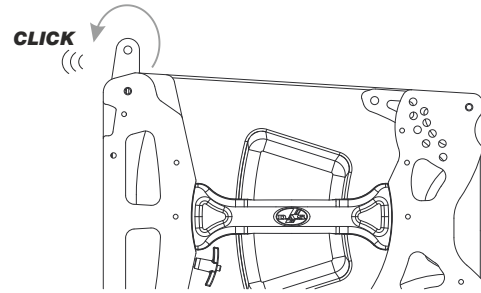

Fig.7

We remove the pin that remains in the enclosure and insert them into the "Fix angle" hole that corresponds to 0° (it is mandatory for a safe transport), as shown in Fig.8 (in red).

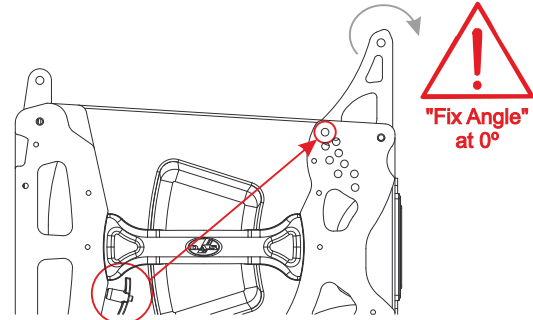

Fig.8

The result, as can be seen in Fig.9, is a group on which we can place the second enclosure in a similar way as we have done with the first on the platform (dashed red line in Fig10).

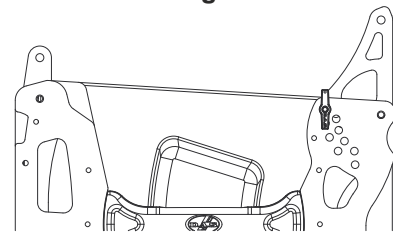

Fig.9

This figure also shows the movements of the safety pins to join the enclosures (red arrows in Fig10).

**Warning: The pins in "Rear Link" and "Fix Angle" must be in the 0 ° hole for transport, always.**



The process can be repeated until reaching the fourth and last enclosure of the group, to lift the front rods as shown in Fig.7.

Now we will lift the rear rod but we will put the "Fix Angle" pin in 7°, we will put the top of the platform that we had removed at the beginning with the same pins, as shown in Fig.11.

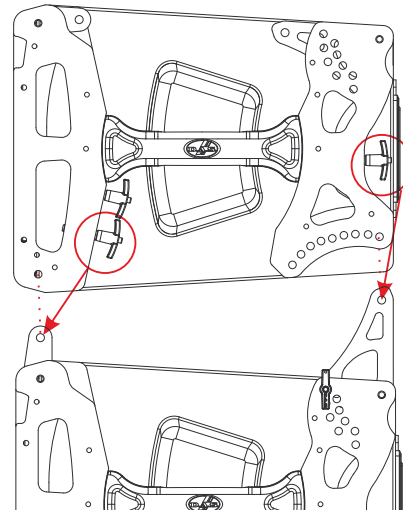

Fig.10

The complete group of 4 units is as shown in Fig.12.

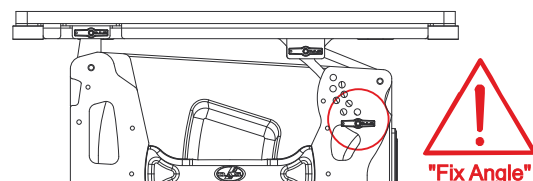

Fig.11

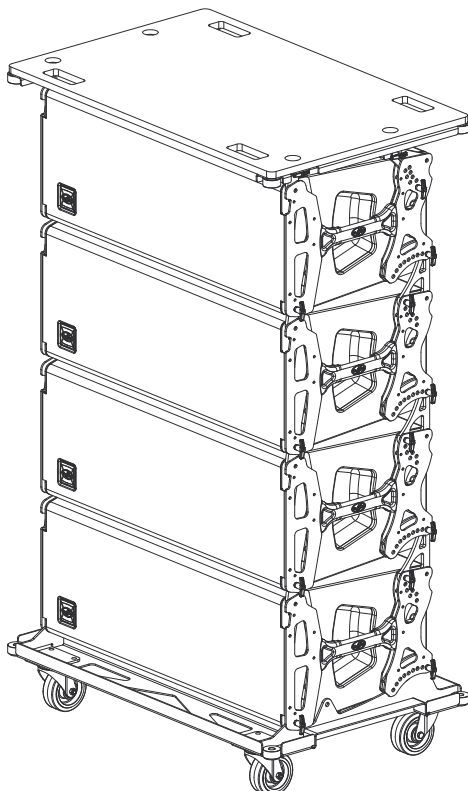

Fig.12



## Array mounting of groups of 4 units on a flatbed dolly

Groups of three or four units are easy to transport by truck.

We will see in this section the assembly of a system array with groups of four units.

The first group with 4 units will be the superior group, that is to say, the group where we will install the AX-EV212.

To assemble the AX, we will remove the top and we will save it and these pins.

Next, we will change the "Fix Angle" at 0° (Fig.13).

Now, we will assemble the lateral pieces (the pieces of AX with the silkscreen visible from the side). We will insert the security pins as shown Fig.14.

**Warning: Verify the correct installation of the security pins. These pins will support the inferior load.**



Moreover, we will join the Pick Up with the lift motor. If we use two lift motors, we will use a second Pick Up (Fig.15).

With the help of the Ease Focus software, we can determine which point is the correct one to join the side pieces (Fig.16) with the Pick Up, with the help of the security pins.

If we use two lift motors, we will use a second Pick Up which joins through the same way to the pinpoint marked by Ease Focus.

**Warning: Verify the correct installation of the security pins. These pins will support the inferior load.**

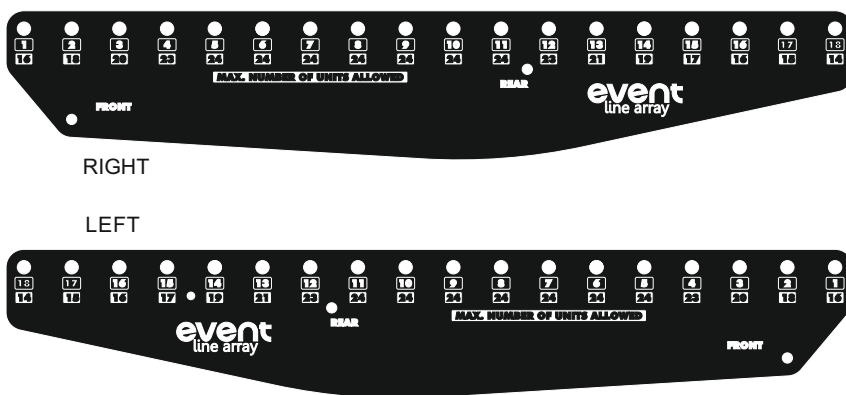
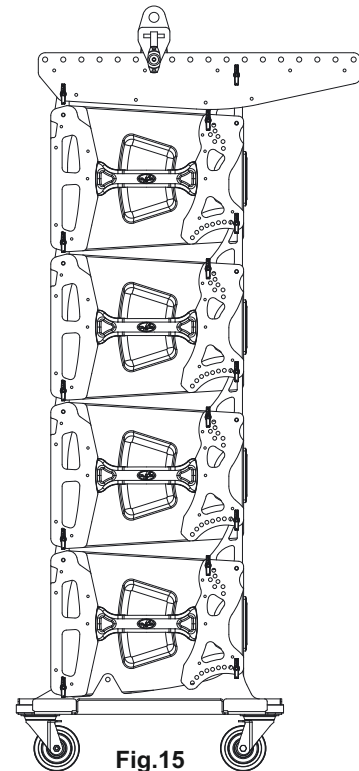
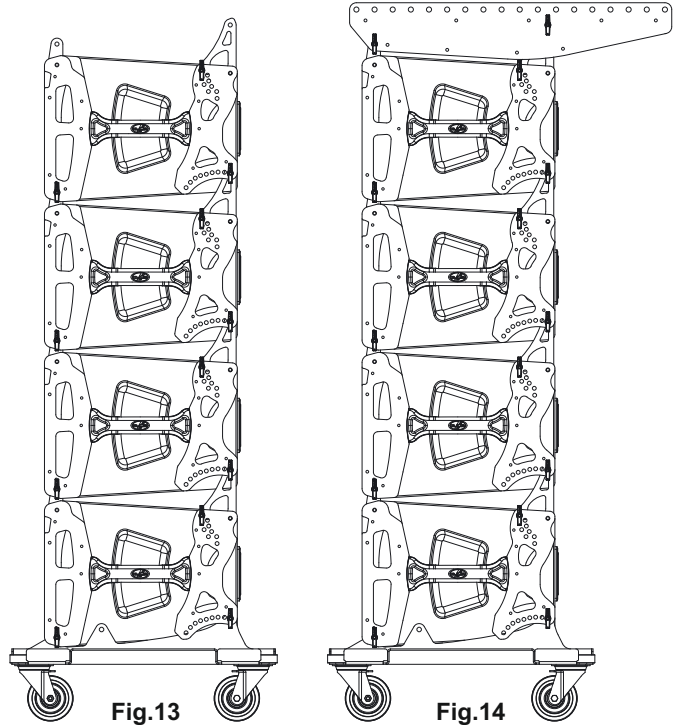

Fig.16

Note that the first enclosure, the one that joins the AX, has an assigned angle of 0° (the safety pin in "Fix Angle" is in the 0 position).

Now we will proceed to assign the angles to each enclosure.

With the help of the Ease Focus program we will know what angle corresponds to each enclosure to obtain an array with the desired response. This process is similar for all the enclosures starting from the second with respect to the first, and similar to the angulation of enclosures of other models.

First we remove the pin of "Rear Link" from the enclosure attached to the AX and we will lift to easily change the angle rod in "Fix angle" (Fig.17 and Fig.18).

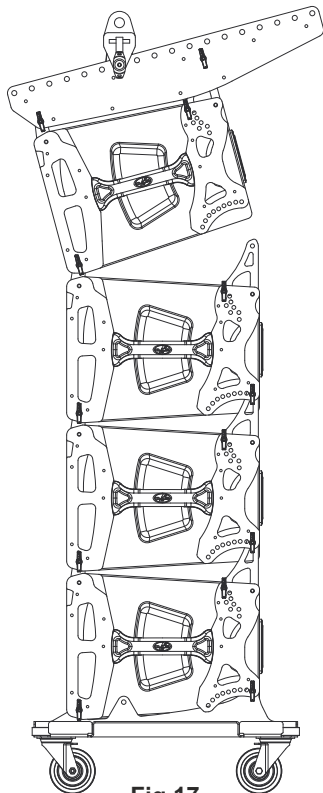

Fig.17

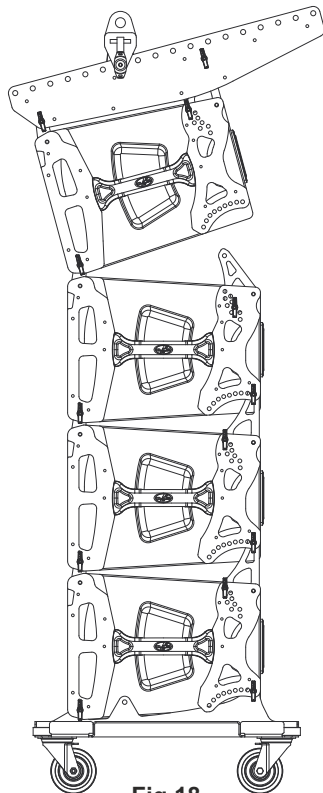

Fig.18

Now we will go down until support the set again, and place the "Rear Link" pin (Fig. 19).

This process will continue until all the enclosures have been angled. And finally, the platform will be removed by placing the lid on it again and holding it with its pins.

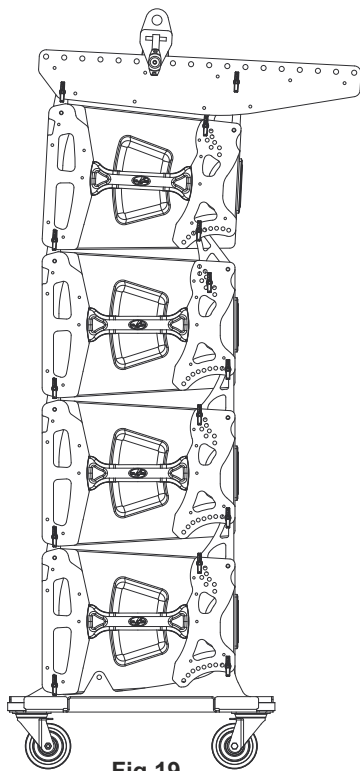

Fig.19

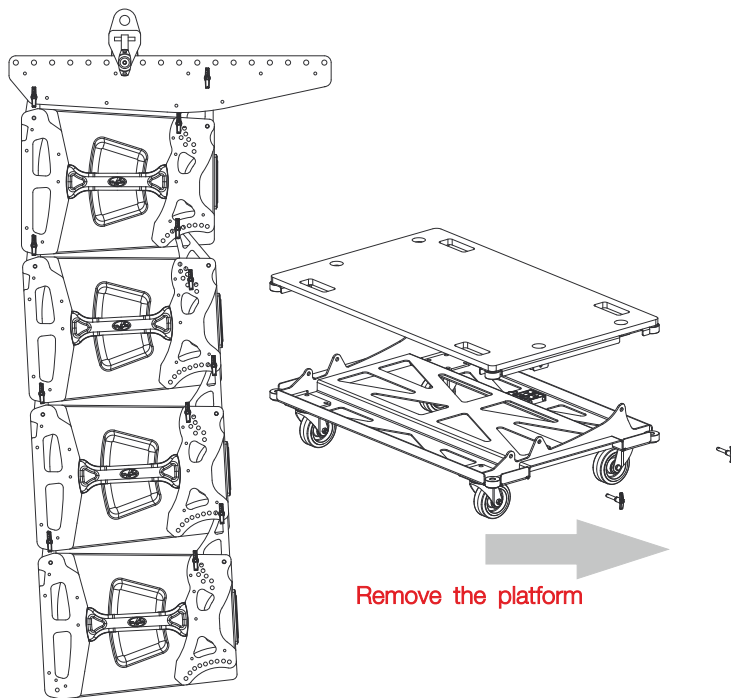

Fig.20

Next, we will place another group of enclosures underneath to continue joining enclosures, and we will repeat the process of angulation of enclosures one by one as indicated above.

As a result we will have the array with the desired angles and that we had obtained with Ease Focus.

## Combination with other models and stacking systems

To be able to combine EVENT-212A (or EVENT-212, 120A), with EVENT-208A (or EVENT-210A) one of these accessories is needed: AX-COMBOEV1208 to combine EVENT-212A (or EVENT-212, 120A), with EVENT- 208A and AX-COMBOEV1210 to combine EVENT-212A (or EVENT-212, 120A), with EVENT-210A.

First, the assembly of the combo will be done on the group of enclosures of smaller width (Fig.21 and Fig.22), either EVENT-208A or EVENT-210A, and then, it will be joined to the array of the EVENT-212A (or EVENT-212, 120A) as if it were one more unit of EVENT-212A, because the width already coincides, leaving the grouping as shown in Fig.23.

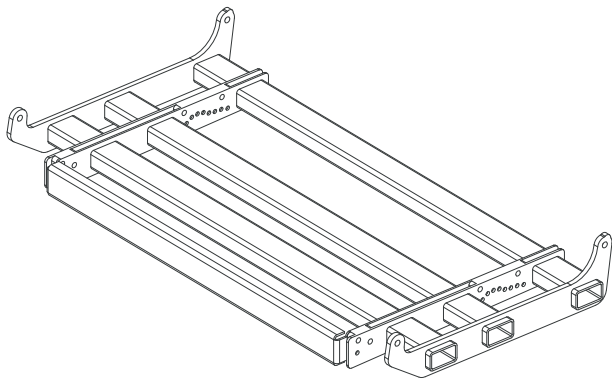

AX-COMBOEV1208

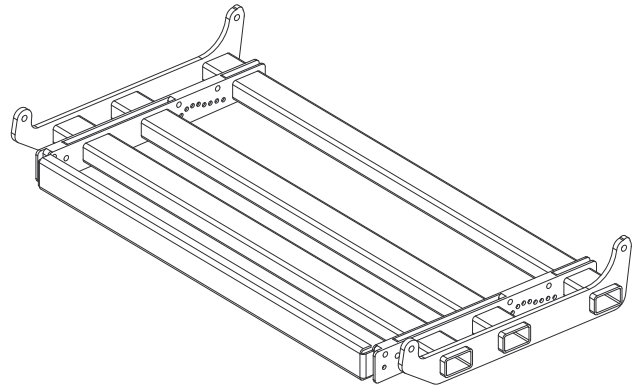

AX-COMBOEV1210

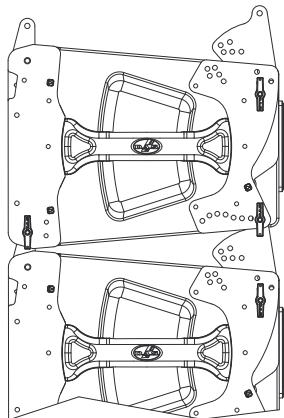

Fig.21

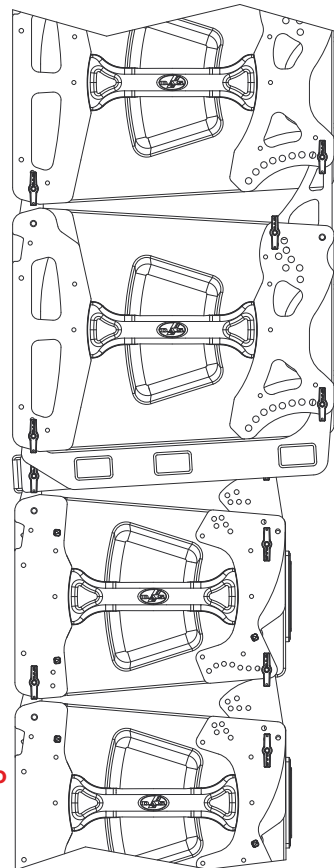

Fig.23

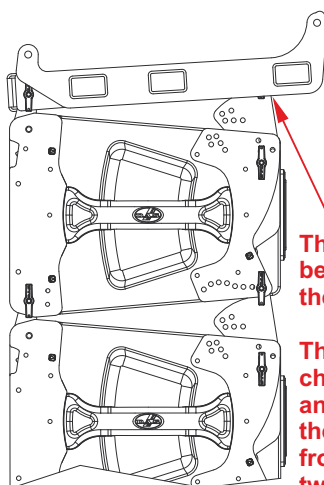

Fig.22

**The rear pins must be inserted inside the Combo.**

**The angle that we can choose between the Combo and the first enclosure of the lower group can be from 0° to 10°, as between two enclosures of that array group.**

The platform PL-EV212S has more a mission of transport of units (maximum 4 units), than for a stacked use as such, since the angulation of the boxes could make the whole unstable and makes its use for stacked systems not recommendable.

On the other hand the PL-EV121S does not have this problem and could be used both for transport and for stacked use, provided that the number of 2 units of EVENT-121A is not exceeded, at most (Note: the box is stacked sideways on the platform.).)

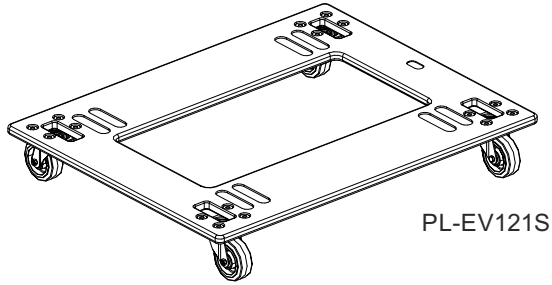

PL-EV121S

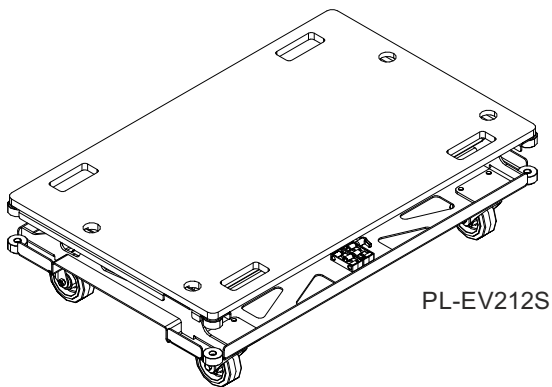
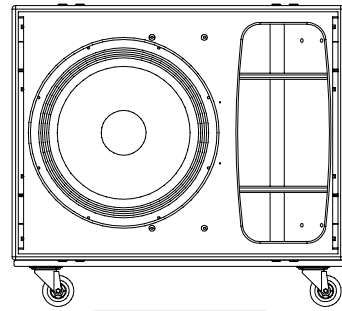

PL-EV212S

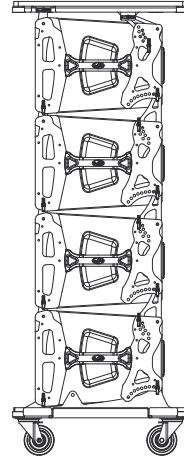

The accessory AXS-EV212 is a platform that allows the stacking of the EVENT-212A and EVENT-212.120A, provided that the maximum number of 4 units is not exceeded, and provided they are properly joined with straps to the EVENT-218A, on those that will be stacked, allowing a simple angulation (see the examples in the lower images).

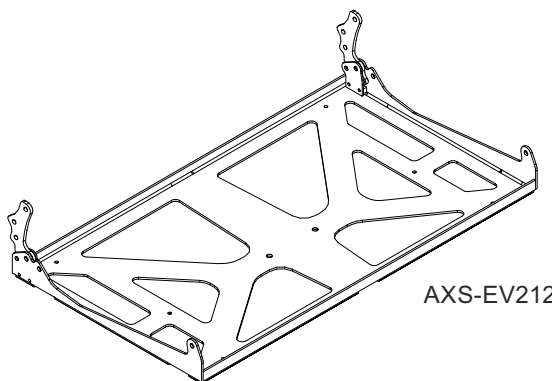
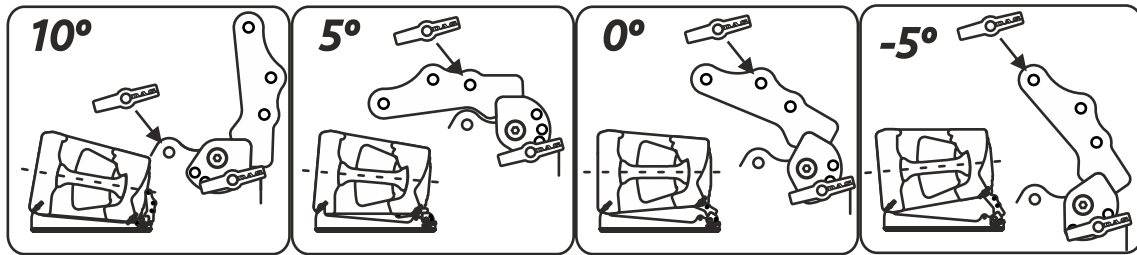

AXS-EV212

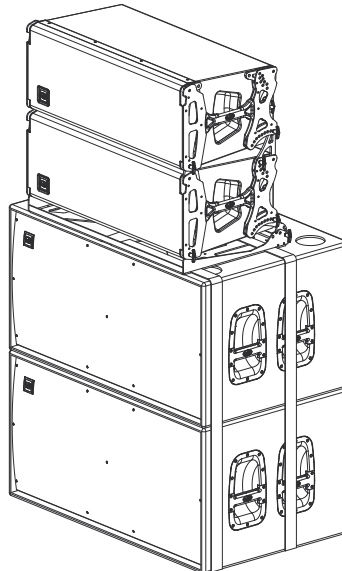

## Transporting

This section describes event units transport recommendations.

We will start with two examples of configurations and we will recommend different ways of loading them inside a truck.

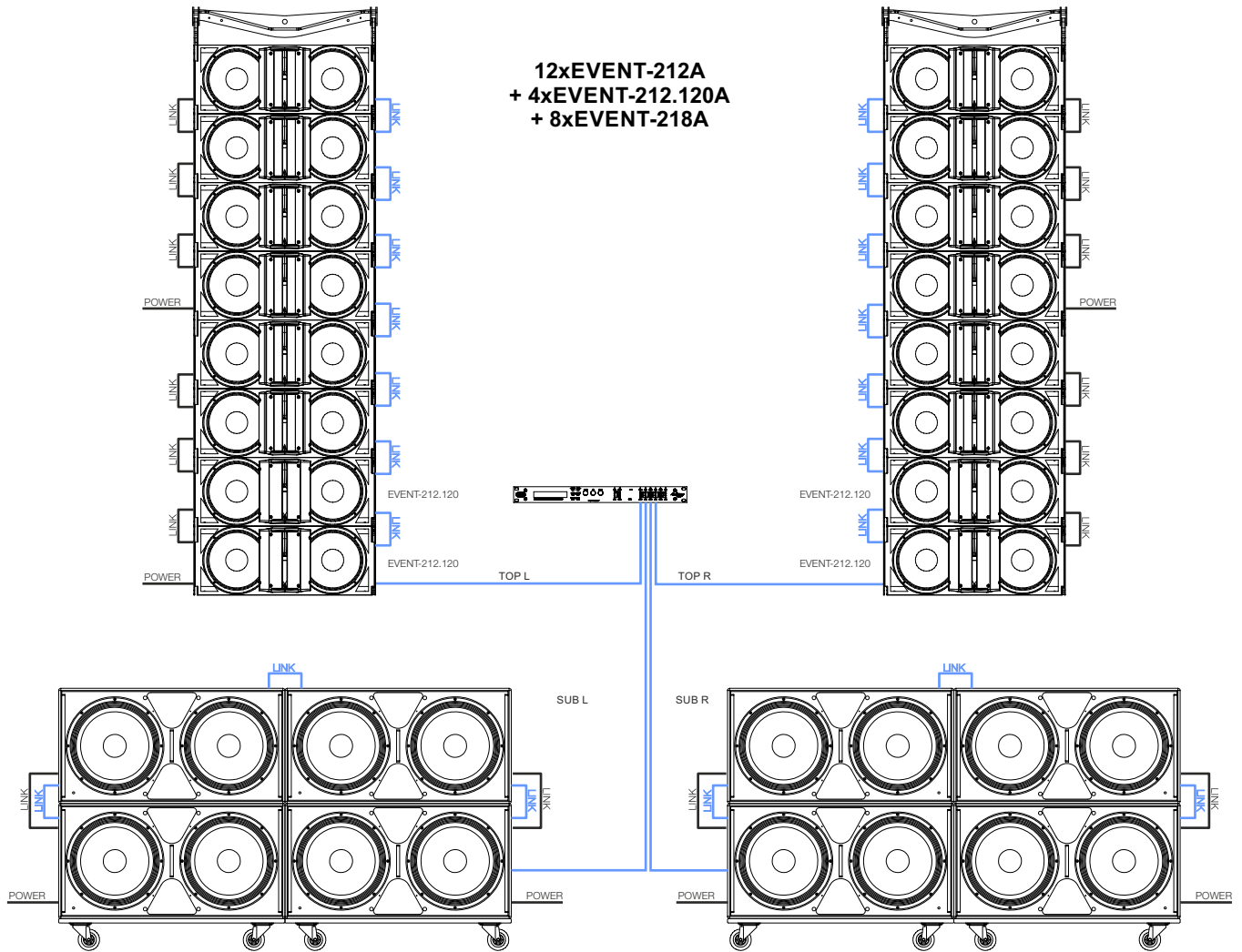

**12xEVENT-212A  
+ 4xEVENT-212.120A  
+ 8xEVENT-218A**

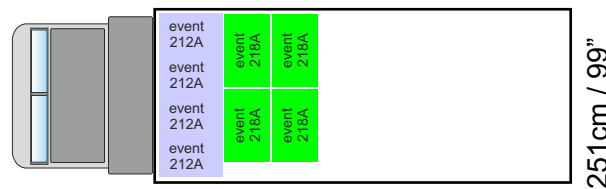
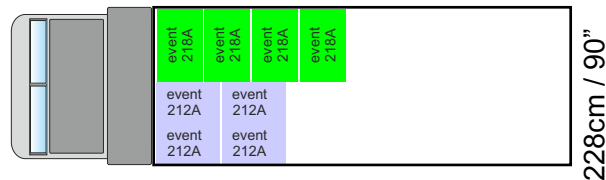
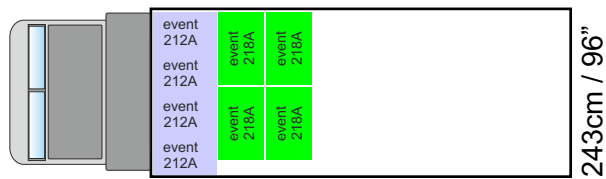

Here is the second example:

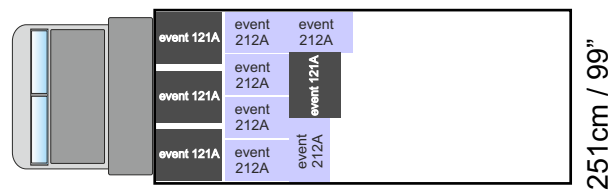
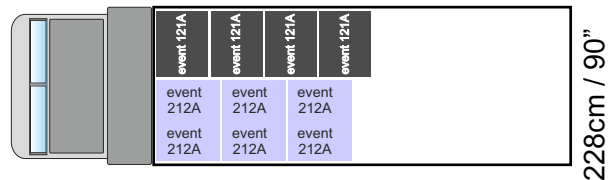
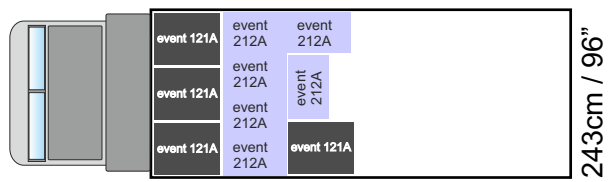
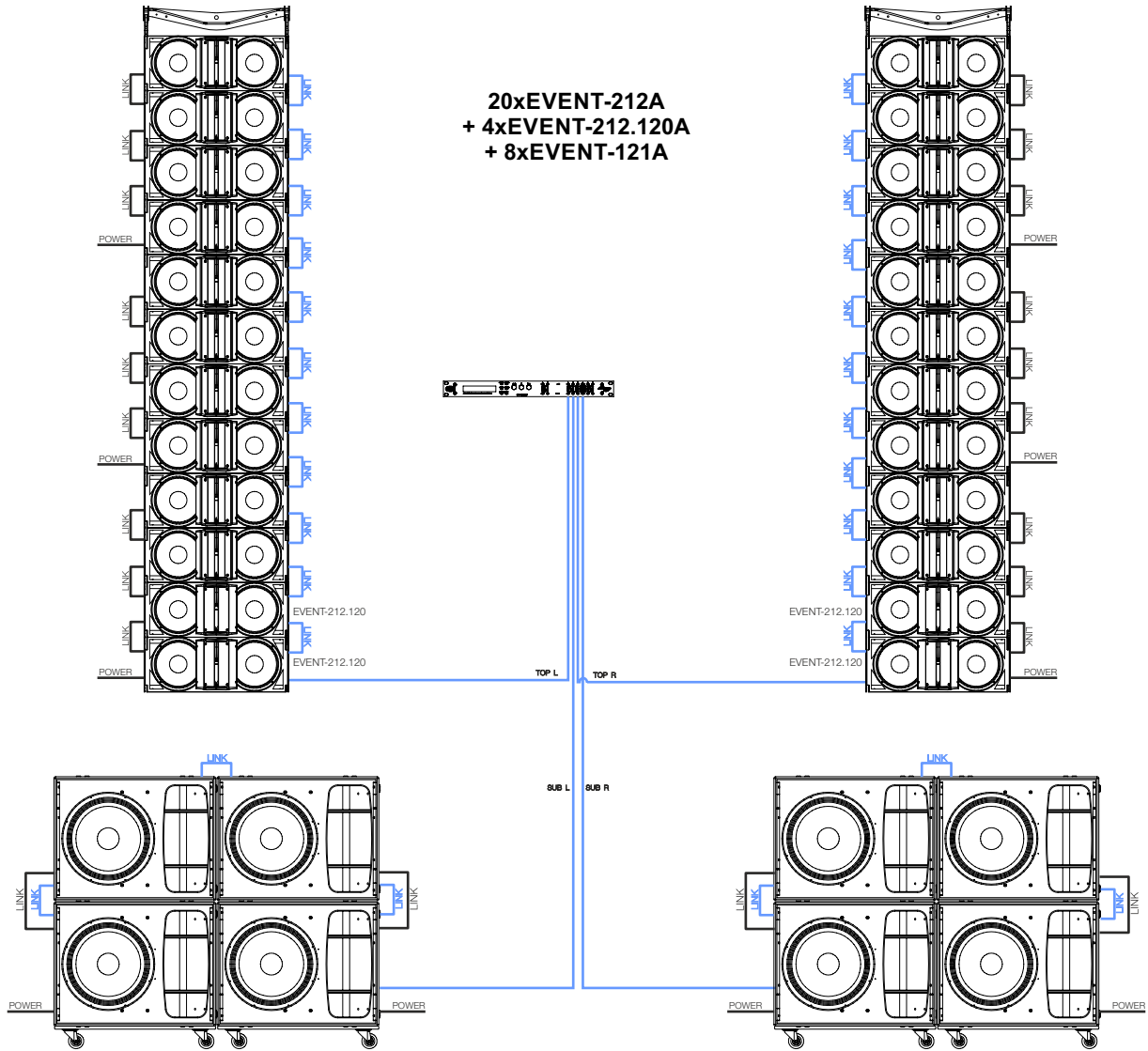

## ANNEX : Line connections: unbalanced and balanced

There are two basic ways to transport an audio signal with microphone or line level:

**Unbalanced line:** Utilising a two conductor cable, it transports the signal as the voltage between them. Electromagnetic interference can get added to the signal as undesired noise. Connectors that carry unbalanced signals have two pins, such as RCA (Phono) and 1/4" (6.35mm, often referred to as jack) mono. 3 pin connector such as XLR (Cannon) may also carry unbalanced signals if one of the pins is unused.

**Balanced line:** Utilising a three conductor cable, one of them acts as a shield against electromagnetic noise and is the ground conductor. The other two have the same voltage with respect to the ground conductor but with opposite signs. The noise that cannot be rejected by the shield affects both signal conductors in the same way. At the device's input the two signals get summed with opposite sign, so that noise is cancelled out while the programme signal doubles in level. Most professional audio devices use balanced inputs and outputs. Connectors that can carry balanced signal have three pins, such as XLR (Cannon) and 1/4" (6.35mm) stereo.

The graphs that follow show the recommended connection with different types of connectors to balanced processor or amplifier inputs. The connectors on the left-hand side come from a signal source, and the ones on the right hand side go to the inputs of the processor or amplifier. Note that on the unbalanced connectors on the left-hand side, two terminals are joined inside the connector. If hum occurs with balanced to balanced connections, try disconnecting the sleeve (ground) on the input connector. Note that the illustrations show what should be connected to what, but that pin locations on an actual XLR connector are different. Also, pin 2 hot is assumed on XLR connectors.

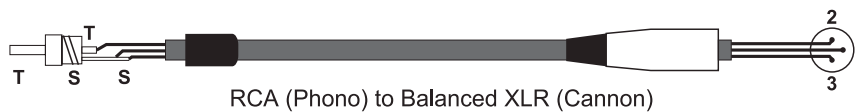
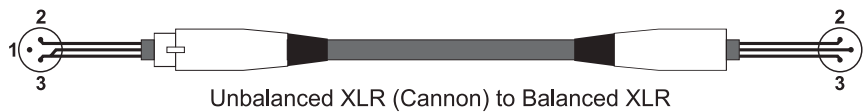
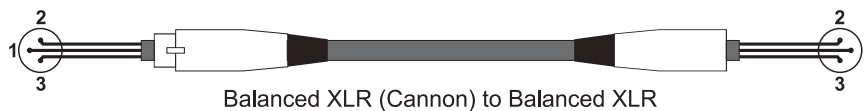



**[www.dasaudio.com](http://www.dasaudio.com)**

**DAS Audio Group, S.L.**  
C/. Islas Baleares, 24  
46988 Fuente del Jarro  
Valencia, SPAIN  
Tel. +34 96 134 0860

**DAS Audio of America, INC.**  
6900 NW 52th Street  
Miami, FL. 33166 - U.S.A.  
TOLL FREE: 1 888 DAS 4 USA

**DAS Audio Asia PTE. LTD.**  
3 Temasek Avenue, Centennial  
Tower #34-36  
Singapore 039190  
Tel. +65 6549 7760

**DAS do Brasil LTDA.**  
Rua Dos Andradas, 382 SL  
Santa Efigênia, São Paulo  
Brasil. CEP: 01208-000  
Tel. +551133330764