



Quam

BACK BOXES

ERD8U

ROUND

UL LISTED - Steel, 262 CID,
Two (2) Snap-In, Tie-Off Straps

GENERAL DESCRIPTION

The ERD8U is a UL Listed, 262 CID, round, stackable, steel loudspeaker back box with a circular, molded polystyrene damping pad fitted to the inside top of the enclosure with two (2) snap-in, tie-off straps included.

INTENDED USE - Indoor Environment

UL Listed 1480 (UUMW) As a Fire Signaling Device	When installed with supplied instructions and requirements of NFPA 72, NEC and AHJ
UL Listed 2043	Suitable for use in air handling spaces



MECHANICAL SPECIFICATIONS

Internal Displacement	262 Cubic Inches (CI)
Attachment Points	2X Snap-In, Tie-Off Straps
Attachment to Tile Bridge	Twist Tabs Through Side Flange
Electrical Access	Top: 1X Side: 4X - 90° Apart

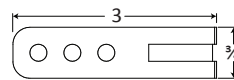
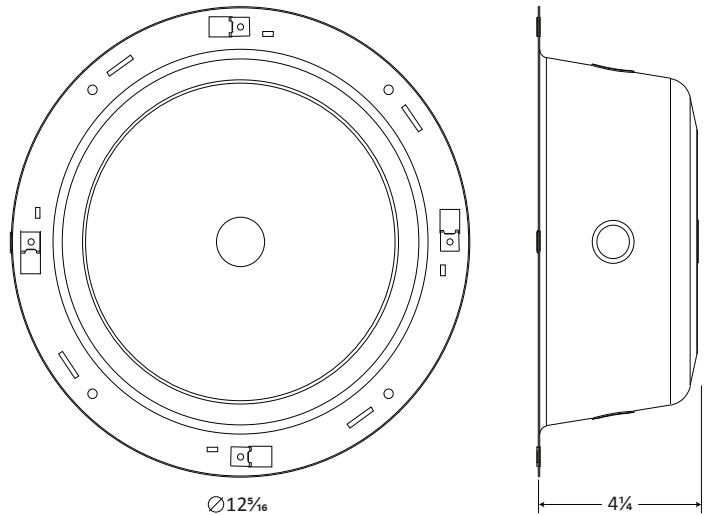

Snap-In, Tie-Off Strap
(not to scale)

Recommended construction sequences, installation instructions, and A&E Specifications are available in various formats in the Specs and Diagrams section at: www.QuamSpeakers.com



QUAM-NICHOLS COMPANY, INC.
234 East Marquette Road. Chicago, IL. 60637
t: 1-800-NEED-NOW (800-633-3669)
f: 1-888-NEED-NOW (888-633-3669)
e: NeedNow@QNC.com
www.QuamSpeakers.com

©2017 Quam-Nichols Company reserves the right to make changes and/or improvements to its products at any time and without notice.