



Features

- **Rigid-pipe design with ball-in-socket base permits flexible positioning**
- **Sturdy metal base mounts to table, desk or podium with included hardware**
- **Low-profile element provides uniform cardioid polar pattern with 120° acceptance angle**
- **Superior off-axis rejection for maximum gain before feedback**
- **UniGuard® RFI-shielding technology offers outstanding rejection of radio frequency interference (RFI)**
- **UniSteep® filter provides a steep low-frequency attenuation to improve sound pickup without affecting voice quality**
- **Available interchangeable elements permit angle of acceptance from 100° to 360°**

Description

The ES905CL is a wide-range condenser microphone with a cardioid polar pattern. It is designed for quality sound reinforcement, professional recording and other demanding sound pickup applications.

The rigid-pipe design with ball-in-socket base permits flexible positioning while maintaining a clean appearance.

The microphone requires 11V to 52V phantom power for operation.

The microphone is equipped with UniGuard® RFI-shielding technology, which offers outstanding rejection of radio frequency interference (RFI).

The microphone's cardioid polar pattern provides a 120° angle of acceptance. Additional interchangeable elements with omnidirectional (360°) and hypercardioid (100°) pickup patterns are available.

The microphone includes a 2.9 m (9.5') permanently attached miniature cable. Its free end connects to the provided AT8538 power module via a special TA3F-type connector designed to optimize RFI immunity. The output of the power module is a 3-pin XLRM-type connector.

A recessed switch in the power module permits choice of flat response or low-frequency roll-off (via integral 80 Hz high-pass UniSteep® filter) to help control undesired ambient noise.

The microphone comes equipped with a power module and hardware for table-mounting the microphone's (attached) isolation base plate. The microphone is enclosed in a rugged housing with a low-reflectance black finish.

Installation and Operation

The ES905CL requires 11V to 52V phantom power for operation.

Output is low impedance (Lo-Z) balanced. The signal appears across Pins 2 and 3; Pin 1 is ground (shield). Output phase is "Pin 2 hot"—positive acoustic pressure produces positive voltage at Pin 2.

The microphone is intended for mounting to a hard surface, such as a table, desk, or podium using the isolation base plate. **ATTENTION! Do not remove ball-in-socket assembly from the base plate.** The microphone is supplied with three #8 x 1" black oxide wood screws for mounting the microphone. The cable can exit out the back of the microphone or be routed through a hole in the mounting surface. To install the microphone with bottom-routed cable: Drill a 4 mm (⁵/₃₂" hole centered in the area where the microphone mount is to be positioned. Pass the cable extending from the microphone mount through this hole and mount the microphone into position using the screws provided.

The attached wire mesh windscreen with internal pop protection effectively reduces noise from plosives, wind and ventilation air currents.

An integral 80 Hz high-pass UniSteep® filter provides easy switching from a flat frequency response to a low-end roll-off. The roll-off position reduces the microphone's sensitivity to popping in close vocal use. It also reduces the pickup of low-frequency ambient noise (such as traffic, air-handling systems, etc.), room reverberation and mechanically coupled vibrations. To engage the UniSteep® filter, use the end tip of a paperclip or other small pointed instrument to slide the switch toward the "bent" line.

Avoid leaving the microphone in the open sun or in areas where temperatures exceed 110° F (43° C) for extended periods. Extremely high humidity should also be avoided.

Note: Audio-Technica has developed a special RFI-shielding mechanism that is an integral part of the connectors in the Engineered Sound® line. If you remove or incorrectly replace the connector, you may adversely affect the unit's RFI immunity. Audio-Technica offers a crimp tool (ATCT) and RFI shields that enable you to shorten the cable and correctly reinstall the connector while maintaining the highest level of RFI immunity.

Architect's and Engineer's Specifications

The microphone shall be a fixed-charge condenser designed for permanent installation tabletop mounting. It shall have a cardioid polar pattern with a uniform 120° angle of acceptance and a frequency response of 60 Hz to 20,000 Hz. It shall be capable of accepting optional interchangeable elements for additional polar patterns. The microphone shall operate from an external 11V to 52V DC phantom power source. It shall be capable of handling sound input levels up to 138 dB with a dynamic range of 111 dB. Nominal open-circuit output voltage shall be 12.5 mV at 1 V, 1 Pascal. Output shall be low impedance balanced (250 ohms). It shall offer outstanding rejection of radio frequency interference (RFI).

The microphone shall have a 2.9 m (9.5') permanently attached miniature cable, terminating in a special TA3F-type output connector designed to optimize RFI immunity. The output connector shall connect to a TB3M-type jack on the included power module. The power module shall contain a recessed switch to permit choice of flat response or 80 Hz low-frequency roll-off. The output of the power module shall be a 3-pin XLRM-type connector.

Mounting screws shall be provided with the microphone. The microphone shall be equipped with an attached wire mesh windscreen with internal pop protection.

ES905CL

The microphone shall be a small-diameter ball-in-socket, rigid-pipe design, with an isolation base plate for table mounting. The microphone shall be 523.4 mm (20.61") long and have a head diameter of 24.6 mm (0.97"). Weight shall be 330 grams (11.6 oz). Finish shall be low-reflectance black.

The Audio-Technica ES905CL is specified.

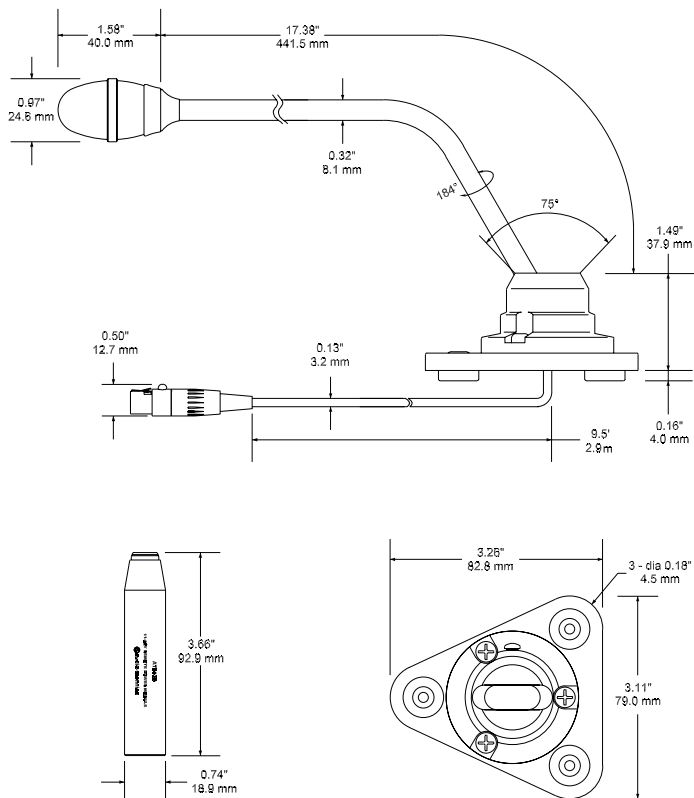

Specifications

Element	Fixed-charge back plate, permanently polarized condenser
Polar pattern	Cardioid
Frequency response	60-20,000 Hz
Low frequency roll-off	80 Hz, 18 dB/octave
Open circuit sensitivity	-38 dB (12.5 mV) re 1V at 1 Pa
Impedance	250 ohms
Maximum input sound level	138 dB SPL, 1 kHz at 1% T.H.D.
Dynamic range (typical)	111 dB, 1 kHz at Max SPL
Signal-to-noise ratio¹	67 dB, 1 kHz at 1 Pa
Phantom power requirements	11-52V DC, 2 mA typical
Switch	Flat, roll-off
Weight	Microphone: 330 g (11.6 oz) Power module: 81 g (2.9 oz)
Dimensions	Microphone: 523.4 mm (20.61") long, 24.6 mm (0.97") head diameter Power module: 92.9 mm (3.66") long, 18.9 mm (0.74") diameter
Output connector	Power module: Integral 3-pin XLRM-type
Cable	2.9 m (9.5') long (permanently attached to microphone), 3.2 mm (0.13") diameter, 2-conductor shielded cable, terminated with TA3F-type connector
Optional interchangeable elements	ESE-O omnidirectional (360°) ESE-H hypercardioid (100°)
Audio-Technica case style	M37
Accessories furnished	AT8538 power module; three #8 x 1" black oxide wood screws for microphone mount

In the interest of standards development, A.T.U.S. offers full details on its test methods to other industry professionals on request.

1 Pascal = 10 dynes/cm² = 10 microbars = 94 dB SPL

¹ Typical, A-weighted, using Audio Precision System One.

Specifications are subject to change without notice.



frequency response: 60–20,000 Hz

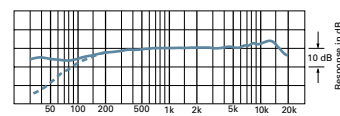

LEGEND — 12° or more on axis
- - - Roll-off

polar pattern

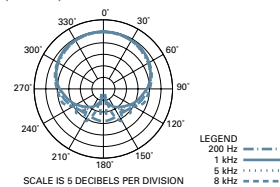

 **audio-technica**

Audio-Technica U.S., Inc., 1221 Commerce Drive, Stow, Ohio 44224
Audio-Technica Limited, Old Lane, Leeds LS11 8AG England
©2010 Audio-Technica U.S., Inc. audio-technica.com

0001-0114-01